



PDHonline Course C575 (4 PDH)

An Introduction to Area Drainage Systems

Instructor: J. Paul Guyer, P.E., R.A., Fellow ASCE, Fellow AEI

2020

PDH Online | PDH Center

5272 Meadow Estates Drive
Fairfax, VA 22030-6658
Phone: 703-988-0088
www.PDHonline.com

An Approved Continuing Education Provider

An Introduction to Area Drainage Systems

J. Paul Guyer, P.E., R.A., Fellow ASCE, Fellow AEI

CONTENTS

1. INTRODUCTION
 2. HYDROLOGY
 3. HYDRAULICS
 4. EROSION CONTROL AND RIPRAP PROTECTION
 5. SUBSURFACE DRAINAGE
- APPENDIX A: REFERENCES
- APPENDIX B: NOTATION
- APPENDIX C: BIBLIOGRAPHY

This course is adapted from the *Unified Facilities Criteria* of the United States government, which is in the public domain, is authorized for unlimited distribution, and is not copyrighted.

The Figures, Tables and Symbols in this document are in some cases a little difficult to read, but they are the best available. **DO NOT PURCHASE THIS COURSE IF THE FIGURES, TABLES AND SYMBOLS ARE NOT ACCEPTABLE TO YOU.**

1. INTRODUCTION

1.1 PURPOSE AND SCOPE. The purpose of this course is to provide an introduction to normal requirements for design of surface and subsurface drainage systems for residential, commercial, institutional and industrial developments. Sound engineering practice should be followed when unusual or special requirements are encountered.

1.2 GENERAL INVESTIGATIONS. An on-site investigation of the system site and tributary area is a prerequisite for study of drainage requirements. Information regarding capacity, elevations, and condition of existing drains will be obtained. Topography, size and shape of drainage area, and extent and type of development; profiles, cross sections, and roughness data on pertinent existing streams and watercourses; and location of possible ponding areas will be determined. Thorough knowledge of climatic conditions and precipitation characteristics is essential. Adequate information regarding soil conditions, including types, permeability or perviousness, vegetative cover, depth to and movement of subsurface water, and depth of frost will be secured. outfall and downstream flow conditions, including high-water occurrences and frequencies, also must be determined. Effect of drainage construction on local interests' facilities and local requirements that will affect the design of the drainage works will be evaluated. Where diversion of runoff is proposed, particular effort will be made to avoid resultant downstream conditions leading to unfavorable public relations, costly litigations, or damage claims. Any agreements needed to obtain drainage easements and/or avoid interference with water rights will be determined at the time of design and consummated prior to initiation of construction. Possible adverse effects on water quality due to disposal of drainage in waterways involved in water-supply systems will be evaluated.

1.3 ENVIRONMENTAL CONSIDERATIONS.

1.3.1 Surface drainage systems have either beneficial or adverse environmental impacts affecting water, land, ecology, and socio-economic considerations. Effects on

surrounding land and vegetation may cause changes in various conditions in the existing environment, such as surface water quantity and quality, groundwater levels and quality, drainage areas, animal and aquatic life, and land use. Environmental attributes related to water could include such items as erosion, flood potential, flow variations, biochemical oxygen demand, content of dissolved solids, nutrients and coliform organisms. These are among many possible attributes to be considered in evaluating environmental impacts, both beneficial and adverse, including effects on surface water and groundwater.

2. HYDROLOGY

2.1 GENERAL. Hydrologic studies include a careful appraisal of factors affecting storm runoff to insure the development of a drainage system or control works capable of providing the required degree of protection. The selection of design storm magnitudes depends not only on the protection sought but also on the type of construction contemplated and the consequences of storms of greater magnitude than the design storm. Ground conditions affecting runoff must be selected to be consistent with existing and anticipated areal development and also with the characteristics and seasonal time of occurrence of the design rainfall. For areas of up to about 1 square mile, where only peak discharges are required for design and extensive ponding is not involved, computation of runoff will normally be accomplished by the scaled Rational Method. For larger areas, when suitable unit-hydrograph data are available or where detailed consideration of ponding is required, computation should be by unit-hydrograph and flow-routing procedures.

2.2 DESIGN STORM.

2.2.1 For such developed portions of installations as administrative, industrial, and residential areas, the design storm will normally be based on rainfall of 10-year frequency. Potential damage or operational requirements may warrant a more severe criterion; in certain storage and recreational areas a lesser criterion may be appropriate.

A lesser criterion may also be employed in regions where storms of an appreciable magnitude are infrequent and either damages or operational capabilities are such that large expenditures for drainage are not justified.)

2.2.2 The design of roadway culverts will normally be based on 10-year rainfall.

Examples of conditions where greater than 10-year rainfall may be used are areas of steep slope in which overflows would cause severe erosion damage; high road fills that impound large quantities of water; and primary diversion structures, important bridges, and critical facilities where uninterrupted operation is imperative.

2.2.3 Protection against flood flows originating from areas exterior to the design area will normally be based on 25-year or greater rainfall, again depending on operational requirements, cost-benefit considerations, and nature and consequences of flood damage resulting from the failure of protective works. Justification for the selected design storm will be presented, and, if appropriate, comparative costs and damages for alternative designs should be included.

2.2.4 Rainfall intensity will be determined from the best available intensity-duration-frequency data. Basic information of this type will be taken from such publications as:

- *Rainfall Frequency Atlas of the United States*. Technical Paper No. 40.
- *Generalized Estimates of Probable Maximum Precipitation and Rainfall-Frequency Data for Puerto Rico and Virgin Islands*. Technical Paper No. 42.
- *Rainfall-Frequency Atlas of the Hawaiian Islands*. Technical Paper No. 43.
- *Probable Maximum Precipitation and Rainfall Frequency Data for Alaska*. Technical Paper No. 47.

These publications may be supplemented as appropriate by more detailed publications and by studies of local rainfall records. For large areas and in studies involving unit hydrography and flowrouting procedures, appropriate design storms must be synthesized from areal and time-distribution characteristics of typical regional rainfalls.

2.2.5 For some areas, it might reasonably be assumed that the ground would be covered with snow when the design rainfall occurs. If so, snowmelt would add to the runoff. It should be noted, however, that the rate of snowmelt under the range of hydro-meteorological conditions normally encountered in drainage design would seldom exceed 0.2 inches per hour and could be substantially less than that rate.

2.2.6 In selecting the design storm and making other design decisions, particular attention must be given to the hazard to life and other disastrous consequences resulting from the failure of protective works during a great flood. Potentially hazardous situations must be brought to the attention of the using service and others concerned so that appropriate steps can be taken.

2.3 INFILTRATION AND OTHER LOSSES.

2.3.1 Principal factors affecting the computation of runoff from rainfall for the design of drainage systems comprise initial losses, infiltration, transitory storage, and, in some areas, percolation into natural streambeds. If necessary data are available, an excellent indication of the magnitudes of these factors can be derived from thorough analysis of past storms and recorded flows by the unit-hydrograph approach. At the onset of a storm, some rainfall is effectively retained in “wetting down” vegetation and other surfaces, in satisfying soil moisture deficiencies, and in filling surface depressions. Retention capacities vary considerably according to surface, soil type, cover, and antecedent moisture conditions. For high intensity design storms of the convective, thunderstorm type, a maximum initial loss of up to 1 inch may be assumed for the first hour of storm precipitation, but the usual values are in the range of 0.25 to 0.50 inches per hour. If the design rainfall intensity is expected to occur during a storm of long

duration, after substantial amounts of immediately prior rain, the retention capacity would have been satisfied by the prior rain and no further assumption of loss should be made.

2.3.2 Infiltration rates depend on type of soils, vegetal cover, and the use to which the areas are subjected. Also, the rates decrease as the duration of rainfall increases. Typical values of infiltration for generalized soil classifications are shown in table 2-1. These infiltration rates are for uncompacted soils. Studies indicate that compacted soils decrease infiltration values from 25 to 75 percent, the difference depending on the degree of compaction and the soil type. Vegetation generally decreases the infiltration capacity of coarse soils and increases that of clayey soils.

<i>Description</i>	<i>Soil group symbol</i>	<i>Infiltration, inches/hour</i>
Sand and gravel mixture	GW, GP SW, SP	0.8-1.0
Silty gravels and silty sands to inorganic silt, and well-developed loams	GM, SM ML, MH OL	0.3-0.6
Silty clay sand to sandy clay	SC, CL	0.2-0.3
Clays, inorganic and organic	CH, OH	0.1-0.2
Bare rock, not highly fractured	-----	0.0-0.1

Table 2-1
Typical Values of Infiltration Rates

2.3.3 Peak rates of runoff are reduced by the effect of transitory storage in watercourses and minor ponds along the drainage route. The effects are reflected in the C factor of the Rational Formula or in the shape of the unit hydrography. Flow-routing techniques must be used to predict major storage effects caused by natural topography or man-made developments in the area.

2.3.4 Streambed percolation losses to direct runoff need to be considered only for sandy, alluvial watercourses, such as those found in arid and semiarid regions. Rates of streambed percolation commonly range from 0.15 to 0.5 cubic feet per second per acre of wetted area.

2.4 RUNOFF COMPUTATIONS.

2.4.1 Design procedures for drainage facilities involve computations to convert rainfall intensities expected during the design storm into runoff rates which can be used to size the various elements of the storm drainage system. There are two basic approaches: first, direct estimates of the proportion of average rainfall intensity that will appear as the peak runoff rate; and, second, hydrography methods that depict the time-distribution of runoff events after accounting for losses and attenuation of the flow over the surface to the point of design. The first approach is exemplified by the Rational Method which is used in the large majority of engineering offices in the United States. It can be employed successfully and consistently by experienced designers for drainage areas up to 1 square mile in size. *Design and Construction of Sanitary and Storm Sewers*, ASCE Manual No. 37, and *Airport Drainage*, FAA AC 150/5320-5B, explain and illustrate use of the method. A modified method is outlined below. The second approach encompasses the analysis of unit-hydrograph techniques to synthesize complete runoff hydrography.

2.4.2 To compute peak runoff the empirical formula $Q = C (1-F) A$ can be used; the terms are defined Appendix B. This equation is known as the modified rational method.

2.4.2.1 C is a coefficient expressing the percentage to which the peak runoff is reduced by losses (other than infiltration) and by attenuation owing to transitory storage. Its value depends primarily on surface slopes and irregularities of the tributary area, although accurate values of C cannot readily be determined. For most developed areas, the apparent values range from 0.6 to 1.0. However, values as low as 0.20 for C may be assumed in areas with low intensity design rainfall and high infiltration rates on flat terrain. A value of 0.6 may be assumed for areas left ungraded where meandering- flow

and appreciable natural-ponding exists, slopes are 1 percent or less, and vegetal cover is relatively dense. A value of 1.0 may be assumed applicable to paved areas and to smooth areas of substantial slope with virtually no potential for surface storage and little or no vegetal cover.

2.4.2.2 The design intensity is selected from the appropriate intensity-duration-frequency relationship for the critical time of concentration and for the design storm frequency. Time of concentration is usually defined as the time required, under design storm conditions, for runoff to travel from the most remote point of the drainage area to the point in question. In computing time of concentration, it should be kept in mind that, even for uniformly graded bare or turfed ground, overland flow in “sheet” form will rarely travel more than 300 or 400 feet before becoming channelized and thence move relatively faster. Also, for design, the practical minimum time of concentration for roofs or paved areas and for relatively small unpaved areas upstream of the uppermost inlet of a drainage system is 10 minutes; smaller values are rarely justifiable; values up to 20 minutes may be used if resulting runoff excesses will not cause appreciable damage. A minimum time of 20 minutes is generally applicable for turfed areas. Further, the configuration of the most remote portion of the drainage area may be such that the time of concentration would be lengthened markedly and thus design intensity and peak runoff would be decreased substantially. In such cases, the upper portion of the drainage areas should be ignored and the peak flow computation should be based only on the more efficient, downstream portion.

2.4.2.3 For all durations, the infiltration rate is assumed to be the constant amount that is established following a rainfall of 1 hour duration. Where F varies considerably within a given drainage area, a weighted rate may be used; it must be remembered, however, that previous portions may require individual consideration, because a weighted overall value for F is proper only if rainfall intensities are equal to or greater than the highest infiltration rate within the drainage area. In design of military construction drainage systems, factors such as initial rainfall losses and channel percolation rarely enter into runoff computations involving the Rational Method. Such losses are accounted for in the selection of the C coefficient.

2.4.3 Where basic hydrologic data on concurrent rainfall and runoff are adequate to determine unit hydrography for a drainage area, the uncertainties inherent in application of the Rational Method can largely be eliminated. Apparent I0SS rates determined from unit-hydrograph analyses of recorded floods provide a good basis for estimating loss rates for storms of design magnitude. Also, flow times and storage effects are accounted for in the shape of the unit-hydrograph. Where basic data are inadequate for direct determination of unit-hydrographs, use may be made of empirical methods for synthesis. Use of the unit-hydrograph method is particularly desirable where designs are being developed for ponds, detention reservoirs, and pump stations; where peak runoff from large tributary areas is involved in design; and where large-scale protective works are under consideration. Here, the volume and duration of storm runoff, as opposed to peak flow, may be the principal design criteria for determining the dimensions of hydraulic structures.

2.4.4 Procedures for routing storm runoff through reservoir-type storage and through stream channels can be found in publications listed in the appendices and in the available publications on these subjects.

3. HYDRAULICS

3-1. GENERAL. Hydraulic design of the required elements of a system for drainage or for protective works may be initiated after functional design criteria and basic hydrologic data have been determined. The hydraulic design continually involves two prime considerations, namely, the flow quantities to which the system will be subjected, and the potential and kinetic energy and the momentum that are present. These considerations require that the hydraulic grade line and, in many cases, the energy grade line for design and pertinent relative quantities of flow be computed, and that conditions whereby energy is lost or dissipated must be carefully analyzed. The phenomena that occur in flow of water at, above, or below critical depth and in change from one of these flow classes to another must be recognized. Water velocities

must be carefully computed not only in connection with energy and momentum considerations, but also in order to establish the extent to which the drainage lines and water-courses may be subjected to erosion or deposition of sediment, thus enabling determination of countermeasures needed. The computed velocities and possible resulting adjustments to the basic design layout often affect certain parts of the hydrology. Manning's equation is most commonly used to compute the mean velocities of essentially horizontal flow that occurs in most elements of a system:

$$V = (1.486/n) R^{2/3} S^{1/2}$$

The terms are defined in appendix B. Values of n for use in the formula are contained in the professional literature.

3.2 CHANNELS.

3.2.1 Open channels on areas range in form from graded swales and bladed ditches to large channels of rectangular or trapezoidal cross section. Swales are commonly used for surface drainage of graded areas around buildings and within housing developments. They are essentially triangular in cross section, with some bottom rounding and very flat side slopes, and normally no detailed computation of their flow-carrying capacity is required. Ditches are commonly used for collection of surface water in outlying areas and along roadway shoulders. Larger open channels, which may be either wholly within the ground or partly formed by levees, are used principally for perimeter drains, for upstream flow diversion or for those parts of the drainage system within a built-up area where construction of a covered drain would be unduly costly or otherwise impractical. They are also used for rainfall drainage disposal. Whether a channel will be lined or not depends on erosion characteristics, possible grades, maintenance requirements, available space, overall comparative costs, and other factors. The need for providing a safety fence not less than 4 feet high along the larger channels (especially those carrying water at high velocity) will be considered, particularly in the vicinity of residential areas.

3.2.2 The discussion that follows will not attempt to cover all items in the design of an open channel; however, it will cite types of structures and design features that require special consideration.

3.2.3 Apart from limitations on gradient imposed by available space, existing utilities, and drainage confluences is the desirability of avoiding flow at or near critical depths. At such depths, small changes in cross section, roughness, or sediment transport will cause instability, with the flow depth varying widely above and below critical. To insure reasonable flow stability, the ratio of invert slope to critical slope should be not less than 1.29 for supercritical flow and not greater than 0.76 for subcritical flow. Unlined earth channel gradients should be chosen that will product stable subcritical flow at non-erosive velocities. In regions where mosquito-borne diseases are prevalent, special attention must be given in the selection of gradients for open channels to minimize formation of breeding areas.

3.2.4 Recommended maximum permissible velocities and Froude numbers for non-erosive flow are given in the professional literature. Channel velocities and Froude numbers of flow can be controlled by providing drop structures or other energy dissipators, and to a limited extent by widening the channel thus decreasing flow depths or by increasing roughness and depth. If non-erosive flows cannot be attained, the channel can be lined with turf, asphaltic or portland cement concrete, and ungrouted or grouted rubble; for small ditches, half sections of pipe can be used, although care must be taken to prevent entrance and side erosion and undermining and ultimate displacement of individual sections. The choice of material depends on the velocity, depth and turbulence involved; on the quantities, availability, and cost of materials; and on evaluation of their maintenance. In choosing the material, its effect on flow characteristics may be an important factor. Further, if an impervious lining is to be used, the need for subdrainage and end protection must be considered. Where a series of drop structures is proposed, care must be taken to avoid placing them too far apart, and to insure that they will not be undermined by scour at the foot of the overpour. The

design of energy dissipators and means for scour protection are discussed subsequently.

3.2.5 Side slopes for unlined earth channels normally will be no steeper than 1 on 3 in order to minimize maintenance and permit machine mowing of grass and weeds. Side-slope steepness for paved channels will depend on the type of material used, method of placement, available space, accessibility requirements of maintenance equipment, and economy. Where portland-cement concrete is used for lining, space and overall economic considerations may dictate use of a rectangular channel even though wall forms are required. Rectangular channels are particularly desirable for conveyance of supercritical channel flow. Most channels, however, will convey subcritical flow and be of trapezoidal cross section. For relatively large earth channels involving levees, side slopes will depend primarily on stability of materials used.

3.2.6 An allowance for freeboard above the computed water surface for a channel is provided so that during a design storm the channel will not overflow for such reasons as minor variations in the hydrology or future development, minor superelevation of flow at curves, formation of waves, unexpected hydraulic performance, embankment settlement, and the like. The allowance normally ranges from 0.5 to 3 feet, depending on the type of construction, size of channel, consequences of overflow, and degree of safety desired. Requirements are greater for leveed channels than those wholly within the ground because of the need to guard against overtopping and breaching of embankments where failure would cause a sudden, highly damaging release of water. For areas upstream of culverts and bridges, the freeboard allowance should include possible rises in water surface elevation due to occurrence of greater than design runoff, unforeseen entrance conditions, or blockage by debris. In high velocity flows, the effect of entrained air on flow depth should be considered.

3.2.7 Whenever water flows in a curved alignment, superelevation of the water surface will occur, the amount depending on the velocity and degree of curvature. Further, if the water entering a curve is flowing at supercritical velocity, a wave will be formed on the

surface at the initial point of change in direction, and this wave will be reflected back and forth across the channel in zigzag fashion throughout the curve and for a long distance along the downstream tangent. Where such rises in water surface are less than 0.5 foot, they may normally be ignored because the regular channel freeboard allowance is ample to contain them. Where the rises are substantial, channel wall heights can be held to a minimum and corresponding economy achieved by superelevation the channel bottom to fit the water surface superelevation, and the formation of transverse waves (in supercritical flow) can be effectively eliminated by providing a spiral for each end of the curve. In superelevating the channel, the transition from horizontal to full tilt is accomplished in the spiral. Figure 3-1 is a chart indicating formulas pertinent for use in computing design wall heights under typical superelevation conditions. For practical reasons, the spirals generally used are a modified type consisting of a series of circular arcs of equal length and decreasing radius. Experience has shown that if the curve is to be superelevated, the length of the spiral transition L_t may be short, a safe minimum being given by the following equation:

$$L_t = (15) (V^2 T / R_c g)$$

If spirals are to be used in a non-superelevated channel, the minimum length of spiral L_s required is:

$$L_s = 1.82 VT / (gd)^{1/2}$$

The terms in both equations are defined in appendix B. The rise in water surface at the outside bank of a curved channel with a trapezoidal section can be estimated by the use of the preceding formulas.

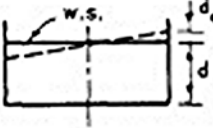
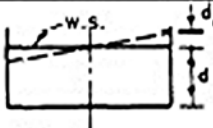
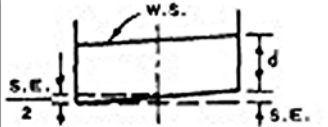
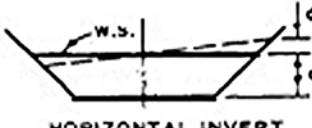
DEPTH $> d_c$ SUBCRITICAL FLOW	SECTION	DEPTH $< d_c$ SUPERCRITICAL FLOW
$d_e = \frac{V^2 T}{2gR_c}$ $HT = d + F.B. + d_e$	 <p>HORIZONTAL INVERT NO SPIRAL</p>	$d'_e = \frac{V^2 T}{gR_c}$ $HT = d + F.B. + d_e$
$d_e = \frac{V^2 T}{2gR_c}$ $HT = d + F.B. + d_e$	 <p>HORIZONTAL INVERT SPIRAL TRANSITION</p>	$d'_e = \frac{V^2 T}{2gR_c}$ $HT = d + F.B. + d_e$
$S.E. = \frac{V^2 T}{gR_c}$ $HT = d + F.B.$	 <p>SUPERELEVATED INVERT SPIRAL TRANSITION</p>	$S.E. = \frac{V^2 T}{gR_c}$ $HT = d + F.B.$
$d_e = \frac{V^2 T}{2gR_c}$ $HT = d + F.B. + d_e$	 <p>HORIZONTAL INVERT WITH OR WITHOUT SPIRAL TRANSITION †</p>	$d'_e = \frac{V^2 T}{gR_c}$ $HT = d + F.B. + d_e$

LEGEND

F.B. FREEBOARD IN FEET
V VELOCITY IN FEET PER SECOND
d DEPTH IN FEET
 d_e RISE ABOVE d DUE TO CENTRIFUGAL FORCE IN FEET
 d'_e RISE ABOVE d DUE TO CENTRIFUGAL FORCE AND TRANSVERSE WAVES IN FEET
S.E. DIFFERENCE IN ELEVATION OF WATER SURFACE BETWEEN RAILS IN FEET
T TOP WIDTH AT WATER SURFACE IN FEET
 R_c RADIUS OF CURVATURE CENTER LINE OF CHANNEL IN FEET
HT WALL HEIGHT IN FEET
g ACCELERATION OF GRAVITY IN FEET PER SECOND²

NOTE: WHEN SUPERELEVATION IS LESS THAN 4% APPLY THE SUPERELEVATION OF THE INVERT, BUT LET $HT = \text{DEPTH} + \text{FREEBOARD} + \text{SUPERELEVATION}$.

† IF MODEL STUDIES INDICATE THAT THE SPIRAL TRANSITION CURVE ELIMINATES THE TRANSVERSE WAVES FOR SUPERCRITICAL FLOW, USE d_e INSTEAD OF d'_e .

U. S. Army Corps of Engineers

Figure 3-1
Superelevation Formulas

3.2.8 For most open channel confluences, proper design can be accomplished satisfactorily by computations based on the principle of conservation of momentum. If the channel flows are supercritical, excessive waves and turbulence are likely to occur unless a close balance of forces is achieved. In such confluences, minimum disturbances will result if the tributary inflow is made to enter the main channel in a direction parallel to the main flow, and if the design depth and velocity of the tributary inflow are made equal to those in the main channel. Further, even though minimum disturbances appear likely under such design conditions, it must be remembered that natural floodflows are highly variable, both in magnitude and distribution. Since this variability leads to unbalanced forces and accompanying turbulence, a need may well exist for some additional wall height or freeboard allowance at and downstream from the confluence structure.

3.2.9 Side inflows to channels generally enter over the tops of the walls or in covered drains through the walls. If the main channel is earth, erosion protection frequently is required at (and perhaps opposite) the point of entry. If the sides of a channel through an erodible area are made of concrete or other durable materials and inflows are brought in over them, care must be taken to insure positive entry. There are two methods of conducting storm water into a concrete-lined channel. Entry of large flows over the top is provided by a spillway built as an integral part of the side slope while smaller flows are admitted to the channel by a conduit through the side slope. Gating of conduit is not required at this location because any pending is brief and not damaging. Where covered tributary drains enter, examination must be made to see whether the water in the main channel, if full, would cause damaging backflooding of the tributary area, which would be more damaging than temporary stoppage of the tributary flow. If so, means for precluding backflow must be employed; this can often be accomplished by a flap gate at the drain outfall, and if positive closure is required, a slide gate can be used. If flow in the main channel is supercritical, the design of side inlet structures may require special provisions to minimize turbulence effects.

3.3 BRIDGES.

3.3.1 A bridge is a structure, including supports, erected over a depression or an obstruction, such as water, a highway, or a railway, having a track or passageway for carrying traffic or other moving loads, and having an opening measured along the center of the roadway of more than 20 feet between undercopings of abutments or spring lines of arches, or extreme ends of the openings for multiple boxes; it may include multiple pipes where the clear distance between openings is less than half of the smaller contiguous opening.

3.3.2 Sufficient capacity will be provided to pass the runoff from the design storm determined in accordance with principles given above. Normally such capacity is provided entirely in the waterway beneath the bridge. Sometimes this is not practical, and it may be expedient to design one or both approach roadways as overflow sections for excess runoff. In such an event, it must be remembered that automobile traffic will be impeded, and will be stopped altogether if the overflow depth is much more than 6 inches. However, for the bridge proper, a waterway opening smaller than that required for 10-year storm runoff will be justifiable.

3.3.3 In general, the lowest point of the bridge superstructure shall clear the design water surface by not less than 2 feet for average flow and trash conditions. This may be reduced to as little as 6 inches if the flow is quiet, with low velocity and little or no trash. More than 2 feet will be required if flows are rough or large-size floating trash is anticipated.

3.3.4 The bridge waterway will normally be aligned to result in the least obstruction to streamflow, except that for natural streams consideration will be given to realignment of the channel to avoid costly skews, To the maximum extent practicable, abutment wings will be aligned to improve flow conditions. If a bridge is to span an improved trapezoidal channel of considerable width, the need for overall economy may require consideration of the relative structural and hydraulic merits of onbank abutments with or without piers and warped channel walls with vertical abutments.

3.3.5 To preclude failure by underscour, abutment and pier footings will usually be placed either to a depth of not less than 5 feet below the anticipated depth of scour, or on firm rock if such is encountered at a higher elevation. Large multispan structures crossing alluvial streams may require extensive pile foundations. To protect the channel against the increased velocities, turbulence, and eddies expected to occur locally, revetment of channel sides or bottom consisting of concrete, grouted rock, loose riprap, or sacked concrete will be placed as required.

3.3.6 Where flow velocities are high, bridges should be of clear span, if at all practicable, in order to preclude serious problems attending debris lodgment and to minimize channel construction and maintenance costs.

3.3.7 It is important that storm runoff be controlled over as much of the contributing watershed as practicable. Diversion channels, terraces, check dams, and similar conventional soil conserving features will be installed, implemented, or improved to reduce velocities and prevent silting of channels and other downstream facilities. When practicable, unprotected soil surfaces within the drainage area will be planted with appropriate erosion-resisting plants. These parts of the drainage area which are located on private property or otherwise under control of others will be considered fully in the planning stages, and coordinated efforts will be taken to assure soil stabilization both upstream and downstream from the construction site.

3.3.8 Engineering criteria and design principles related to traffic, size, load capacity, materials, and structural requirements for highway and railroad bridges are given in AASHTO Standard Specifications for Highway Bridges, design manuals of the different railroad companies, and recommended practices of AREA Manual for Railway Engineering.

3.4 CURB-AND-GUTTER SECTIONS.

3.4.1 Precipitation which occurs upon city streets and adjacent areas must be rapidly and economically removed before it becomes a hazard to traffic. Water falling on the pavement surface itself is removed from the surface and concentrated in the gutters by the provision of an adequate crown. The surface channel formed by the curb and gutter must be designed to adequately convey the runoff from the pavement and adjacent areas to a suitable collection point. The capacity can be computed by using the nomograph for flow in a triangular channel, figure 3-2. This figure can also be used for a battered curb face section, since the battering has negligible effect on the cross sectional area. Limited data from field tests with clear water show that a Manning's n of 0.013 is applicable for pavement. The n value should be raised when appreciable quantities of sediment are present. Figure 3-2 also applies to composite sections comprising two or more rates of cross slope.

3.4.2 Good roadway drainage practice requires the extensive use of curb-and-gutter sections in combination with spillway chutes or inlets and downspouts for adequate control of surface runoff, particularly in hilly and mountainous terrain where it is necessary to protect roadway embankments against formation of rivulets and channels by concentrated flows. Materials used in such construction include portland-cement concrete, asphaltic concrete, stone rubble, sod checks, and prefabricated concrete or metal sections. Typical of the latter are the entrance tapers and embankment protectors made by manufacturers of corrugated metal products. Downspouts as small as 8 inches in diameter may be used, unless a considerable trash problem exists, in which case a large size will be required. When frequent mowing is required, consideration will be given to the use of buried pipe in lieu of open paved channels or exposed pipe. The hydrologic and hydraulic design and the provision of outfall erosion protection will be accomplished in accordance with principles outlined for similar component structures discussed in this manual.

3.4.3 Curbs are used to deter vehicles from leaving the pavement at hazardous points as well as to control drainage. The two general classes of curbs are known as barrier and mountable and each has numerous types and detail designs. Barrier curbs are relatively high and steep faced and designed to inhibit and to at least discourage

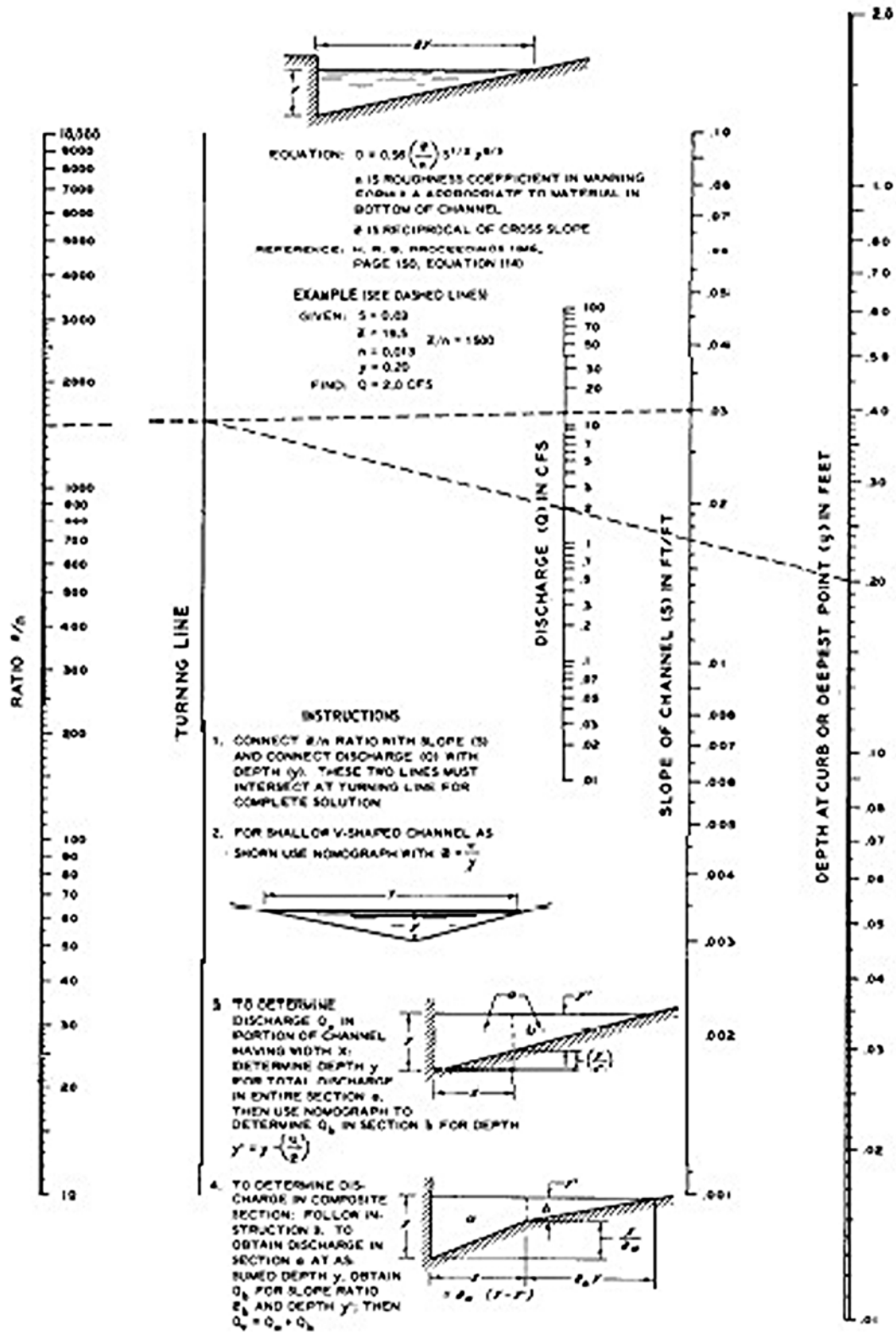

Figure 3-2

Nomograph for flow in triangular channels

vehicles from leaving the roadway. They are considered undesirable on high speed arterials. Mountable curbs are designed so that vehicles can cross them with varying degrees of ease.

3.5 CULVERTS.

3.5.1 A drainage culvert is defined as any structure under the roadway with a clear opening of twenty feet or less measured along the center of the roadway. Culverts are generally of circular, oval, elliptical, arch, or box cross section and may be of either single or multiple construction, the choice depending on available headroom and economy. Culvert materials for permanent-type installations include plain concrete, reinforced concrete, corrugated metal, asbestos cement, and clay. Concrete culverts may be either precast or cast in place, and corrugated metal culverts may have either annular or helical corrugations and be constructed of steel or aluminum. For the metal culverts, different kinds of coatings and linings are available for improvement of durability and hydraulic characteristics. The design of economical culverts involves consideration of many factors relating to requirements of hydrology, hydraulics, physical environment, imposed exterior loads, construction, and maintenance. With the design discharge and general layout determined, the design requires detailed consideration of such hydraulic factors as shape and slope of approach and exit channels, allowable head at entrance (and pending capacity, if appreciable), tailwater levels, hydraulic and energy grade lines, and erosion potential. A selection from possible alternative designs may depend on practical considerations such as minimum acceptable size, available materials, local experience concerning corrosion and erosion, and construction and maintenance aspects. If two or more alternative designs involving competitive materials of equivalent merit appear to be about equal in estimated cost, plans will be developed to permit contractor's options or alternate bids, so that the least construction cost will result.

3.5.2 In most localities, culvert pipe is available in sizes to 36 inches diameter for plain concrete, 144 inches or larger for reinforced concrete, 120 inches for standard and

helically corrugated metal (plain, polymer coated, bituminous coated, part paved, and fully paved interior), 36 inches for asbestos cement or clay, and 24 inches for corrugated polyethylene pipe. Concrete elliptical in sizes up to 116 x 180 inches, concrete arch in sizes up to 107 x 169 inches and reinforced concrete box sections in sizes from 3 x 2 feet to 12 x 12 feet are available. Structural plate, corrugated metal pipe can be fabricated with diameters from 60 to 312 inches or more. Corrugated metal pipe arches are generally available in sizes to 142 by 91 inches, and corrugated, structural plate pipe arches in spans to 40 feet. Reinforced concrete vertical oval (elliptical) pipe is available in sizes to 87 by 136 inches, and horizontal oval (elliptical) pipe is available in sizes to 136 by 87 inches. Designs for extra large sizes or for special shapes or structural requirements may be submitted by manufacturers for approval and fabrication. Short culverts under sidewalks (not entrances or driveways) may be as small as 8 inches in diameter if placed so as to be comparatively free from accumulation of debris or ice. Pipe diameters or pipe-arch rises should be not less than 18 inches. A diameter or pipe-arch of not less than 24 inches should be used in areas where wind-blown materials such as weeds and sand may tend to block the waterway. Within the above ranges of sizes, structural requirements may limit the maximum size that can be used for a specific installation.

3.5.3 The selection of culvert materials to withstand deterioration from corrosion or abrasion will be based on the following considerations:

3.5.3.1 Rigid culvert is preferable where industrial wastes, spilled petroleum products, or other substances harmful to bituminous paving and coating in corrugated metal pipe are apt to be present. Concrete pipe generally should not be used where soil is more acidic than pH 5.5 or where the fluid carried has a pH less than 5.5 or higher than 9.0. Polyethylene pipe is unaffected by acidic or alkaline soil conditions. Concrete pipe can be engineered to perform very satisfactorily in the more severe acidic or alkaline environments. Type II or Type V cements should be used where soils and/or water have a moderate or high sulfate concentration, respectively. Where highly corrosive substances are to be carried, the resistive qualities of vitrified clay pipe or plastic lined concrete pipe should be considered.

3.5.3.2 Flexible culvert such as corrugated-steel pipe will be galvanized and generally will be bituminous coated for permanent installations. Bituminous coating or polymeric coating is recommended for corrugated steel pipe subjected to stagnant water; where dense decaying vegetation is present to form organic acids; where there is continuous wetness or continuous flow; and in well-drained, normally dry, alkali soils. The polymeric coated pipe is not damaged by spilled petroleum products or industrial wastes. Asbestos-fiber treatment with bituminous coated or a polymeric coated pipe is recommended for corrugated- steel pipe subjected to highly corrosive soils, cinder fills, mine drainage, tidal drainage, salt-water spray, certain industrial wastes, and other severely corrosive conditions; or where extra-long life is desirable. Cathodic protection is rarely required for corrugated-steel-pipe installations; in some instances, its use may be justified. Corrugated-aluminum-alloy pipe, fabricated in all of the shapes and sizes of the more familiar corrugated-steel pipe, evidences corrosion resistance in clear granular materials even when subjected to sea water. Corrugated-aluminum pipe will not be installed in soils that are highly acid (pH less than 5) or alkaline (pH greater than 9), or in metallic contact with other metals or metallic deposits, or where known corrosive conditions are present or where bacterial corrosion is known to exist. Similarly, this type pipe will not be installed in material classified as OH or OL according to the Unified Soil Classification System. Although bituminous coatings can be applied to aluminum-alloy pipe, such coatings do not afford adequate protection (bituminous adhesion is poor) under the aforementioned corrosive conditions. Suitable protective coatings for aluminum alloy have been developed, but are not economically feasible for culverts or storm drains. For flow carrying debris and abrasives at moderate to high velocity, paved-invert pipe may be appropriate. When protection from both corrosion and abrasion is required, smooth-interior corrugated steel pipe may be desirable, since in addition to providing the desired protection, improved hydraulic efficiency of the pipe will usually allow a reduction in pipe size. When considering a coating for use, performance data from users in the area can be helpful. Performance history indicates various successes or failures of coatings and their probable cause and are available from local highway departments.

3.5.4 The capacity of a culvert is determined by its ability to admit, convey, and discharge water under specified conditions of potential and kinetic energy upstream and downstream. The hydraulic design of a culvert for a specified design discharge involves selection of a type and size, determination of the position of hydraulic control, and hydraulic computations to determine whether acceptable headwater depths and outfall conditions will result. In considering what degree of detailed refinement is appropriate in selecting culvert sizes, the relative accuracy of the estimated design discharge should be taken into account. Hydraulic computations will be carried out by standard methods based on pressure, energy, momentum, and loss considerations.

3.5.5 Rounding or beveling the entrance in any way will increase the capacity of a culvert for every design condition. Some degree of entrance improvement should always be considered for incorporation in design. A headwall will improve entrance flow over that of a projecting culvert. They are particularly desirable as a cutoff to prevent saturation sloughing and/or erosion of the embankment. Provisions for drainage should be made over the center of the headwall to prevent scouring along the sides of the walls. A mitered entrance conforming to the fill slope produces little if any improvement in efficiency over that of the straight, sharp-edged, projecting inlet, and may be structurally unsafe due to uplift forces. Both types of inlets tend to inhibit the culvert from flowing full when the inlet is submerged. The most efficient entrances incorporate such geometric features as elliptical arcs, circular arcs, tapers, and parabolic drop-down curves. In general elaborate inlet designs for culverts are justifiable only in unusual circumstances.

3.5.6 Outlets and endwalls must be protected against undermining, bottom scour, damaging lateral erosion and degradation of the downstream channel. The presence of tailwater higher than the culvert crown will affect the culvert performance and may possibly require protection of the adjacent embankment against wave or eddy scour. Endwalls (outfall headwalls) and wingwalls should be used where practical, and wingwalls should flare one on eight from one diameter width to that required for the formation of a hydraulic jump and the establishment of a Froude number in the exit

channel that will insure stability. Two general types of channel instability can develop downstream of a culvert. The conditions are known as either gully scour or a localized erosion referred to as a scour hole. Gully scour is to be expected when the Froude number of flow in the channel exceeds that required for stability. Erosion of this type maybe of considerable extent depending upon the location of the stable channel section relative to that of the outlet in both the vertical and downstream directions. A scour hole can be expected downstream of an outlet even if the downstream channel is stable. The severity of damage to be anticipated depends upon the conditions existing or created at the outlet. See chapter 5 for additional information on erosion protection.

3.5.7 In the design and construction of any drainage system it is necessary to consider the minimum and maximum earth cover allowable in the underground conduits to be placed under both flexible and rigid pavements.

3.5.8 Infiltration of fine-grained soils into drainage pipelines through joint openings is one of the major causes of ineffective drainage facilities. This is particularly a problem along pipes on relatively steep slopes such as those encountered with broken back culverts. Infiltration of backfill and subgrade material can be controlled by watertight flexible joint materials in rigid pipe and with watertight coupling bands in flexible pipe. The results of laboratory research concerning soil infiltration through pipe joints and the effectiveness of gasketing tapes for waterproofing joints and seams are available.

3.6 UNDERGROUND HYDRAULIC DESIGN.

3.6.1 The storm-drain system will have sufficient capacity to convey runoff from the design storm (usually a 10-year frequency for permanent installations) within the barrel of the conduit. Concentration times will increase and average rainfall intensities will decrease as the design is carried to successive downstream points. In general, the incremental concentration times and the point-by-point totals should be estimated to the nearest minute. These totals should be rounded to the nearest 5 minutes

in selecting design intensities from the intensity duration curve. Advantage will be taken of any permanently available surface ponding areas, and their effectiveness determined, in order to hold design discharges and storm-drain sizes to a minimum. Experience indicates that it is feasible and practical in the actual design of storm drains to adopt minimum values of concentration times of 10 minutes for paved areas and 20 minutes for turfed areas. Minimum times of concentration should be selected by weighting for combined paved and turfed areas.

3.6.2 Storm-drain systems will be so designed that the hydraulic gradeline for the computed design discharge is as near optimum depth as practicable and velocities are not less than 2.5 feet per second (nominal minimum for cleansing) when the drains are one-third or more full. To minimize the possibility of clogging and to facilitate cleaning, the minimum pipe diameter or box section height will generally be not less than 12 inches; use of smaller size must be fully justified. Problems attending high-velocity flow should be carefully analyzed, and appropriate provisions made to insure a fully functional project.

3.6.3 Site topography will dictate the location of possible outlets and the general limiting grades for the system. Storm drain depths will be held to the minimum consistent with limitations imposed by cover requirements, proximity of other structures, interference with other utilities, and velocity requirements because deep excavation is expensive. Usually in profile, proceeding downstream, the crowns of conduits whose sizes progressively increase will be matched, the invert grade dropping across the junction structure; similarly, the crowns of incoming laterals will be matched to that of the main line. If the downstream conduit is smaller as on a steep slope, its invert will be matched to that of the upstream conduit. Some additional lowering of an outgoing pipe may be required to compensate for pressure loss within a junction structure.

3.6.4 Manholes or junction boxes usually will be provided at points of change in conduit grade or size, at junctions with laterals or branches and wherever entry for maintenance is required. Distance between points of entry will be not more than approximately 300

feet for conduits with a minimum dimension smaller than 30 inches. If the storm drain will be carrying water at a velocity of 20 feet per second or greater, with high energy and strong forces present, special attention must be given such items as alignment, junctions, anchorage requirements, joints, and selection of materials.

3.7 INLETS.

3.7.1 Storm-drain inlet structures to intercept surface flow are of three general types: drop, curb, and combination. Hydraulically, they may function as either weirs or orifices depending mostly on the inflowing water. The allowable depth for design storm conditions and consequently the type, size and spacing of inlets will depend on the topography of the surrounding area, its use, and consequences of excessive depths. Drop inlets, which are provided with a grated entrance opening, are in general more efficient than curb inlets and are useful in sumps, roadway sags, swales, and gutters. Such inlets are commonly depressed below the adjacent grade for improved interception or increased capacity. Curb inlets along sloping gutters require a depression for adequate interception. Combination inlets may be used where some additional capacity in a restricted space is desired. Simple grated inlets are most susceptible to blocking by trash. Also, in housing areas, the use of grated drop inlets should be kept to a reasonable minimum, preference being given to the curb type of opening. Where an abnormally high curb opening is needed, pedestrian safety may require one or more protective bars across the opening. Although curb openings are less susceptible to blocking by trash, they are also less efficient for interception on hydraulically steep slopes, because of the difficulty of turning the flow into them. Assurance of satisfactory performance by any system of inlets requires careful consideration of the several factors involved. The final selection of inlet types will be based on overall hydraulic performance, safety requirements, and reasonableness of cost for construction and maintenance.

3.7.2 In placing inlets to give an optimum arrangement for flow interception, the following guides apply:

3.7.2.1 At street intersections and crosswalks, inlets are usually placed on the upstream side. Gutters to transport flow across streets or roadways will not be used.

3.7.2.2 At intermediate points on grades, the greatest efficiency and economy commonly result if either grated or curb inlets are designed to intercept only about three-fourths of the flow.

3.7.2.3 In sag vertical curves, three inlets are often desirable, one at the low point and one on each side of the low point where the gutter grade is about 0.2 foot above the low point. Such a layout effectively reduces pond buildup and deposition of sediment in the low area.

3.7.2.4 Large quantities of surface runoff flowing toward main thoroughfares normally should be intercepted before reaching them.

3.7.2.5 At a bridge with curbed approaches, gutter flow should be intercepted before it reaches the bridge, particularly where freezing weather occurs.

3.7.2.6 Where a road pavement on a continuous grade is warped in transitions between superelevated and normal sections, surface water should normally be intercepted upstream of the point where the pavement cross slope begins to change, especially in areas where icing occurs.

3.7.2.7 On roads where curbs are used, runoff from cut slopes and from off-site areas should, wherever possible, be intercepted by ditches at the tops of slopes or in swales along the shoulders and not be allowed to flow onto the roadway. This practice minimizes the amount of water to be intercepted by gutter inlets and helps to prevent mud and debris from being carried onto the pavement.

3.7.3 Inlets placed in sumps have a greater potential capacity than inlets on a slope because of the possible submergence in the sump. Capacities of grated, curb, and combination inlets in sumps will be computed as outlined below. To allow for blockage by trash, the size of inlet opening selected for construction will be increased above the computed size by 100 percent for grated inlets and 25 to 75 percent, depending on trash conditions, for curb inlets and combination inlets.

3.7.3.1 *Grated type (in sump).*

- For depths of water up to 0.4 foot use the weir formula:

$$Q = 3.0 LH^{3/2}$$

If one side of a rectangular grate is against a curb, this side must be omitted in computing the perimeter.

- For depths of water above 1.4 feet use the orifice formula:

$$Q = 0.6 A (2gh)^{1/2}$$

- For depths between 0.4 and 1.4 feet, operation is indefinite due to vortices and other disturbances. Capacity will be somewhere between those given by the preceding formulas.
- Problems involving the above criteria may be solved graphically by use of figure 3-3.

3.7.3.2 Curb Type (in sump). For a curb inlet in a sump, the above listed general concepts for weir and orifice flow apply, the latter being in effect for depths greater than about 1.4h (where h is the height of curb opening entrance). Figure 3-4 presents a graphic method for estimating capacity.

3.7.3.3 Combination Type (in sump). For a combination inlet in a sump no specific formulas are given. Some increase in capacity over that provided singly by either a grated opening or a curb opening may be expected, and the curb opening will operate as a relief opening if the grate becomes clogged by debris. In estimating the capacity, the inlet will be treated as a simple grated inlet, but a safety factor of 25 to 75 percent will be applied.

3.7.3.4 Slotted drain type. For a slotted drain inlet in a sump, the flow will enter the slot as either all orifice type or all weir type, depending on the depth of water at the edge of the slot. If the depth is less than .18 feet, the length of slot required to intercept total flow is equal to:

$$Q/(3.125 \times [d^3 / 2])$$

If the depth is greater than .18 feet, the length of slot required to intercept total flow is equal to:

$$Q/(0.5 w [2gd]^{1/2})$$

where:

d = depth of flow-inches

w = width of slot = 0.146 feet

3.7.4 Each of a series of inlets placed on a slope is usually, for optimum efficiency, designed to intercept somewhat less than the design gutter flow, the remainder being passed to downstream inlets. The amount that must be intercepted is governed by whatever width and depth of bypassed flow can be tolerated from a traffic and safety viewpoint.

Such toleration levels will nearly always be influenced by costs of drainage construction. With the flat street crowns prevalent in modern construction, many gutter flows are relatively wide and in built-up areas some inconveniences are inevitable, especially in regions of high rainfall, unless an elaborate inlet system is provided. The achievement of a satisfactory system at reasonable cost requires careful consideration of use factors and careful design of the inlets themselves. However, it must also be remembered that a limitation on types and sizes for a given project is also desirable, for standardization will lead to lower construction costs. Design of grated, curb, and combination inlets on slopes will be based on principles outlined below.

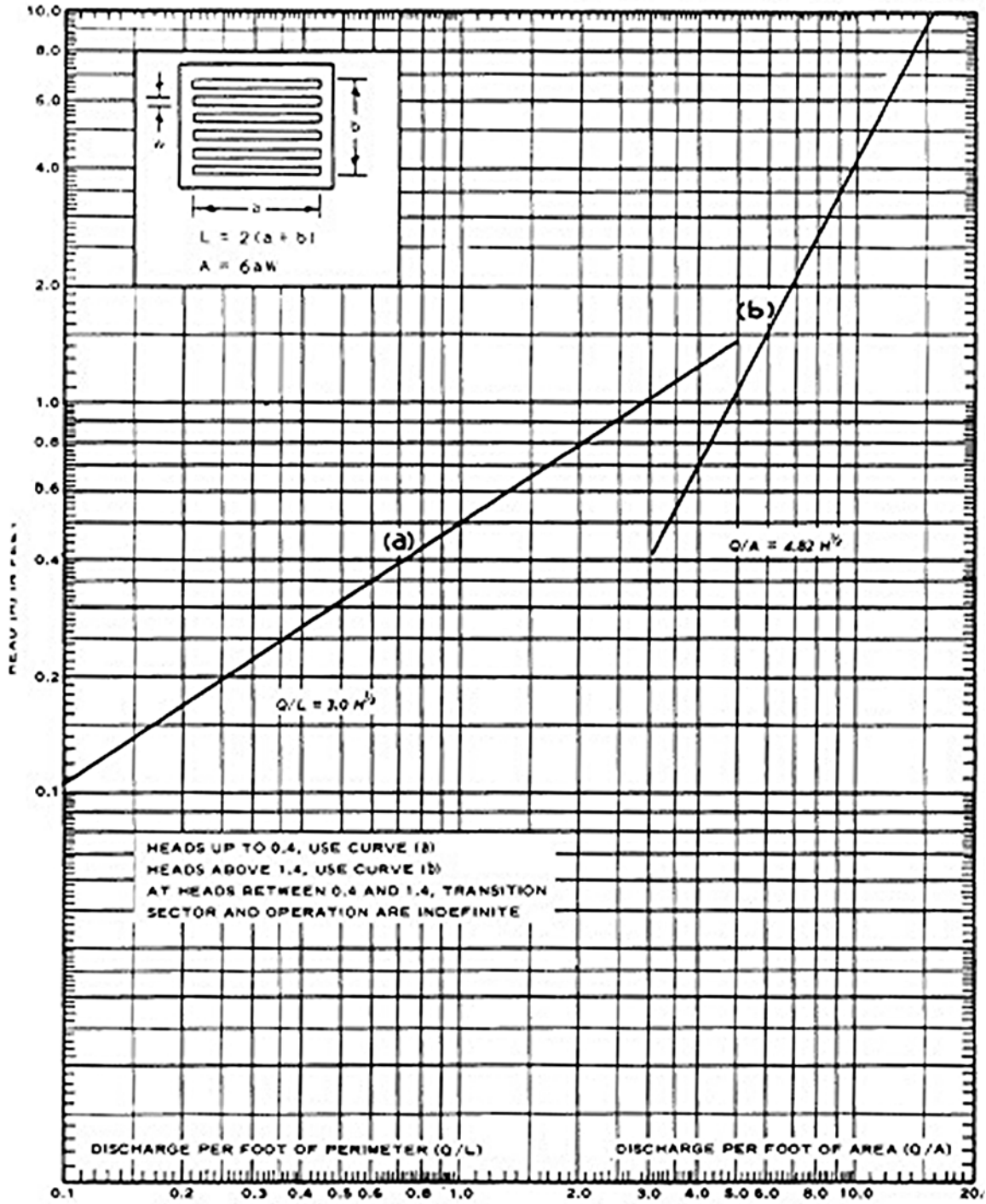

Figure 3-3
Capacity of grate inlet in sump water pond on grate.

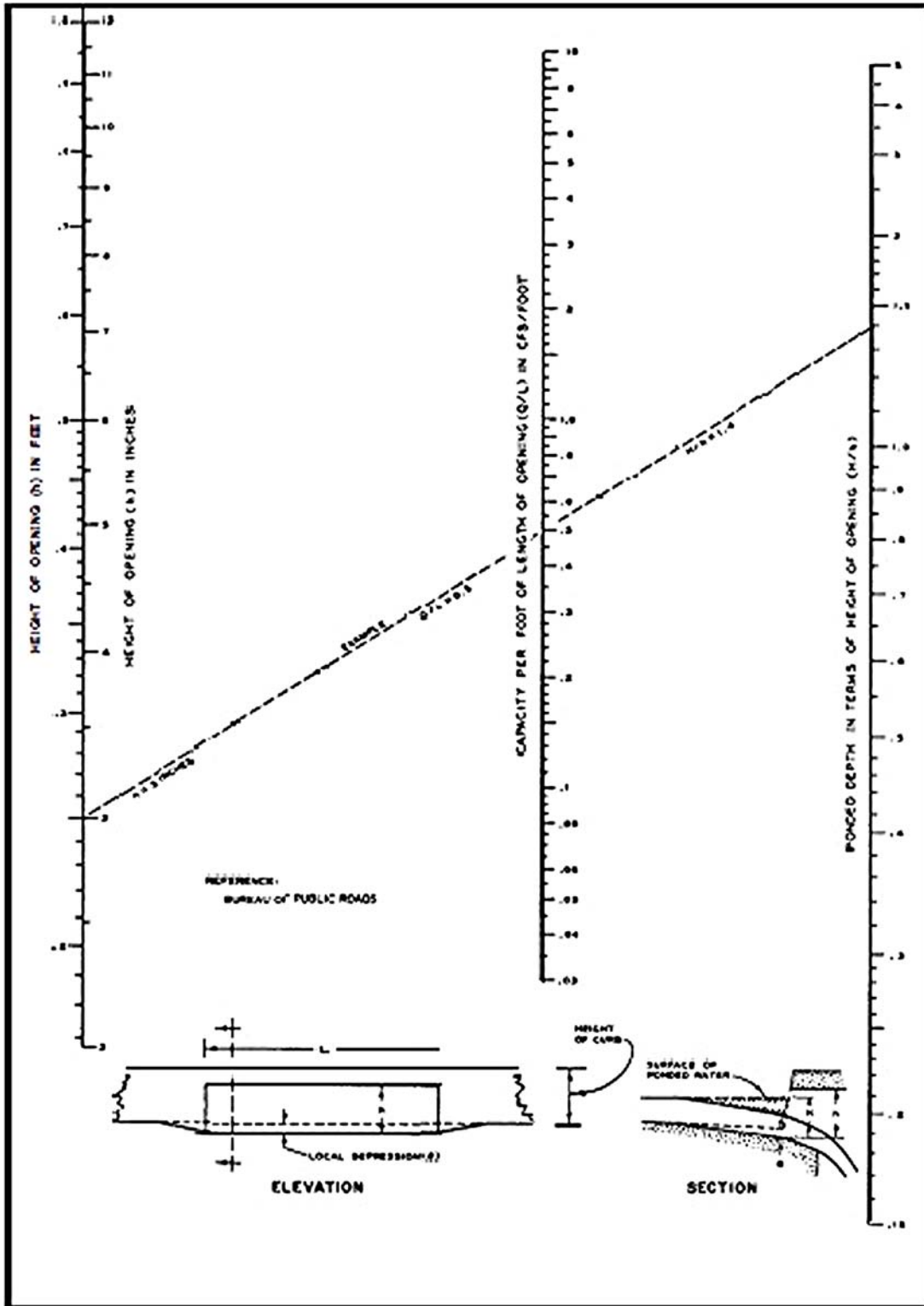

Figure 3-4
Capacity of curb opening inlet at low point in grade

3.7.4.1 Grated type (on slope). A grated inlet placed in a sloping gutter will provide optimum interception of flow if the bars are placed parallel to the direction of flow, if the openings total at least 50 percent of the width of the grate (i.e. normal to the direction of flow), and if the unobstructed opening is long enough (parallel to the direction of flow) that the water falling through will clear the downstream end of the opening. The minimum length of clear opening required depends on the depth and velocity of flow in the approach gutter and the thickness of the grate at the end of the slot. This minimum length may be estimated by the partly empirical formula:

$$L = (V/2)(y+d)^{1/2}$$

A rectangular grated inlet in a gutter on a continuous grade can be expected to intercept all the water flowing in that part of the gutter cross section that is occupied by the grating plus an amount that will flow in along the exposed sides. However, unless the grate is over 3 feet long or greatly depressed (extreme warping of the pavement is seldom permissible), any water flowing outside the grate width can be considered to bypass the inlet. The quantity of flow in the prism intercepted by such a grate can be computed by following instruction 3 in figure 3-2. For a long grate the inflow along the side can be estimated by considering the edge of the grate as a curb opening whose effective length is the total grate length (ignoring crossbars) reduced by the length of the jet directly intercepted at the upstream end of the grate. To attain the optimum capacity of an inlet consisting of two grates separated by a short length of paved gutter, the grates should be so spaced that the carryover from the upstream grate will move sufficiently toward the curb to be intercepted by the downstream grate.

3.7.4.2 Curb type (on slope). In general, a curb inlet placed on a grade is a hydraulically inefficient structure for flow interception. A relatively long opening is required for complete interception because the heads are normally low and the direction of oncoming flows is not favorable. The cost of a long curb inlet must be weighed against that of a drop type with potentially costly grate. The capacity of a curb inlet intercepting all the flow can be calculated by an empirical equation.

The equation is a function of length of clear opening of the inlet, depth of depression of flow line at inlet in feet, and the depth of flow in approach gutter in feet. Depression of the inlet flow line is an essential part of good design, for a curb inlet with no depression is very inefficient. The flow intercepted may be markedly increased without changing the opening length if the flow line can be depressed by one times the depth of flow in the approach gutter. The use of long curb openings with intermediate supports should generally be avoided because of the tendency for the supports to accumulate trash. If supports are essential, they should be set back several inches from the gutter line.

3.7.4.3 *Combination type (on slope)*. The capacity of a combination inlet on a continuous grade is not much greater than that of the grated portion itself, and should be computed as a separate grated inlet except in the following situations. If the curb opening is placed upstream from the grate, the combination inlet can be considered to operate as two separate inlets and the capacities can be computed accordingly. Such an arrangement is sometimes desirable, for in addition to the increased capacity the curb opening will tend to intercept debris and thereby reduce clogging of the grate. If the curb opening is placed downstream from the grate, effective operation as two separate inlets requires that the curb opening be sufficiently downstream to allow flow bypassing the grate to move into the curb opening. The minimum separation will vary with both the cross slope and the longitudinal slope.

3.7.5 Structural aspects of inlet construction should generally be as indicated in figures 3-5, 3-6, and 3-7 which show respectively, standard circular grate inlets, types A and B; typical rectangular grate combination inlet, type C; and curb inlet, type D. It will be noted that the type D inlet provides for extension of the opening by the addition of a collecting trough whose backwall is cantilevered to the curb face. Availability of gratings and standards of municipalities in a given region may limit the choice of inlet types. Grated inlets subject to heavy wheel loads will require grates of precast steel or of built-up, welded steel. Steel grates will be galvanized or bituminous coated. Unusual inlet conditions will require special design.

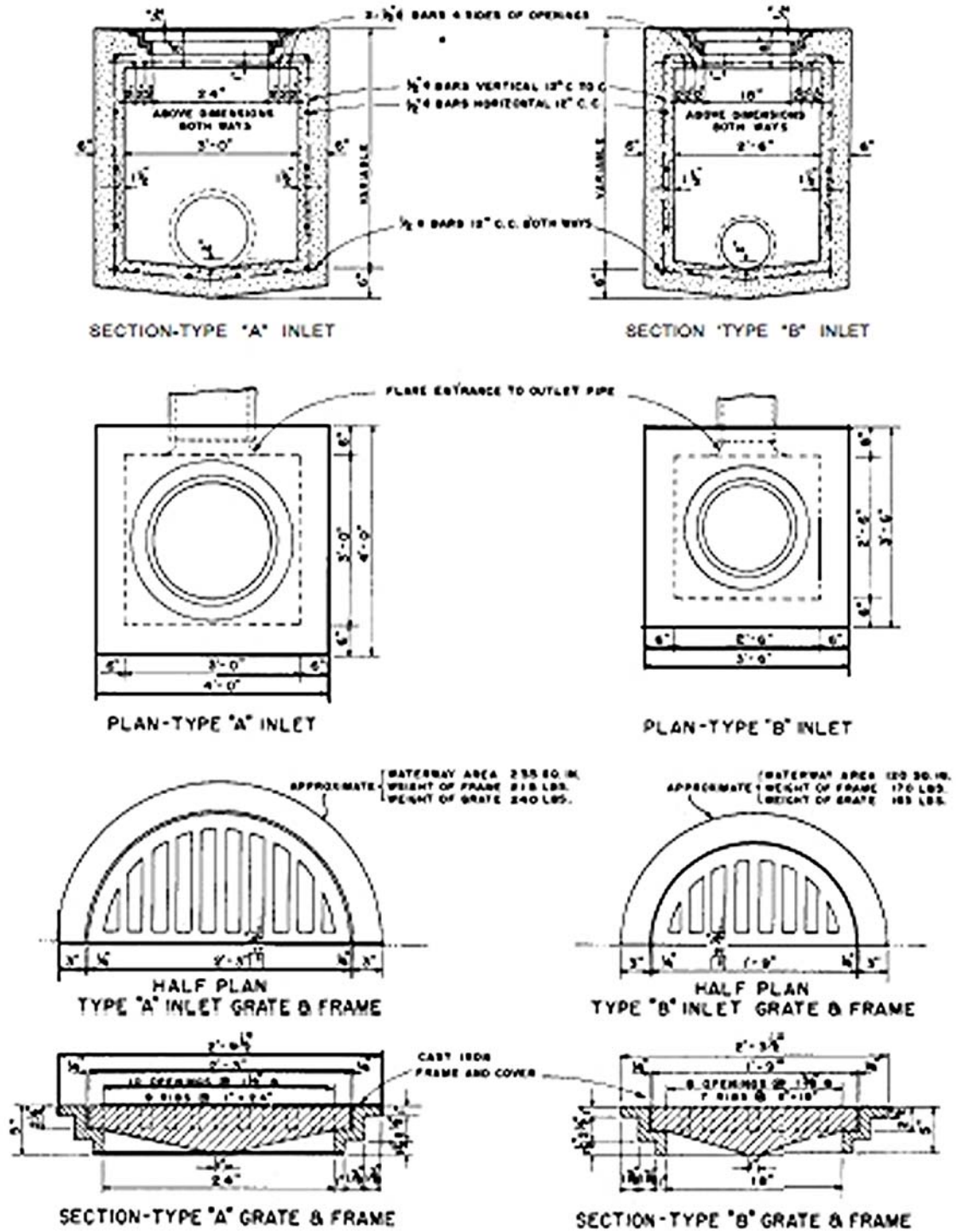

Figure 3-5
Standard Type "A" and Type "B" inlets

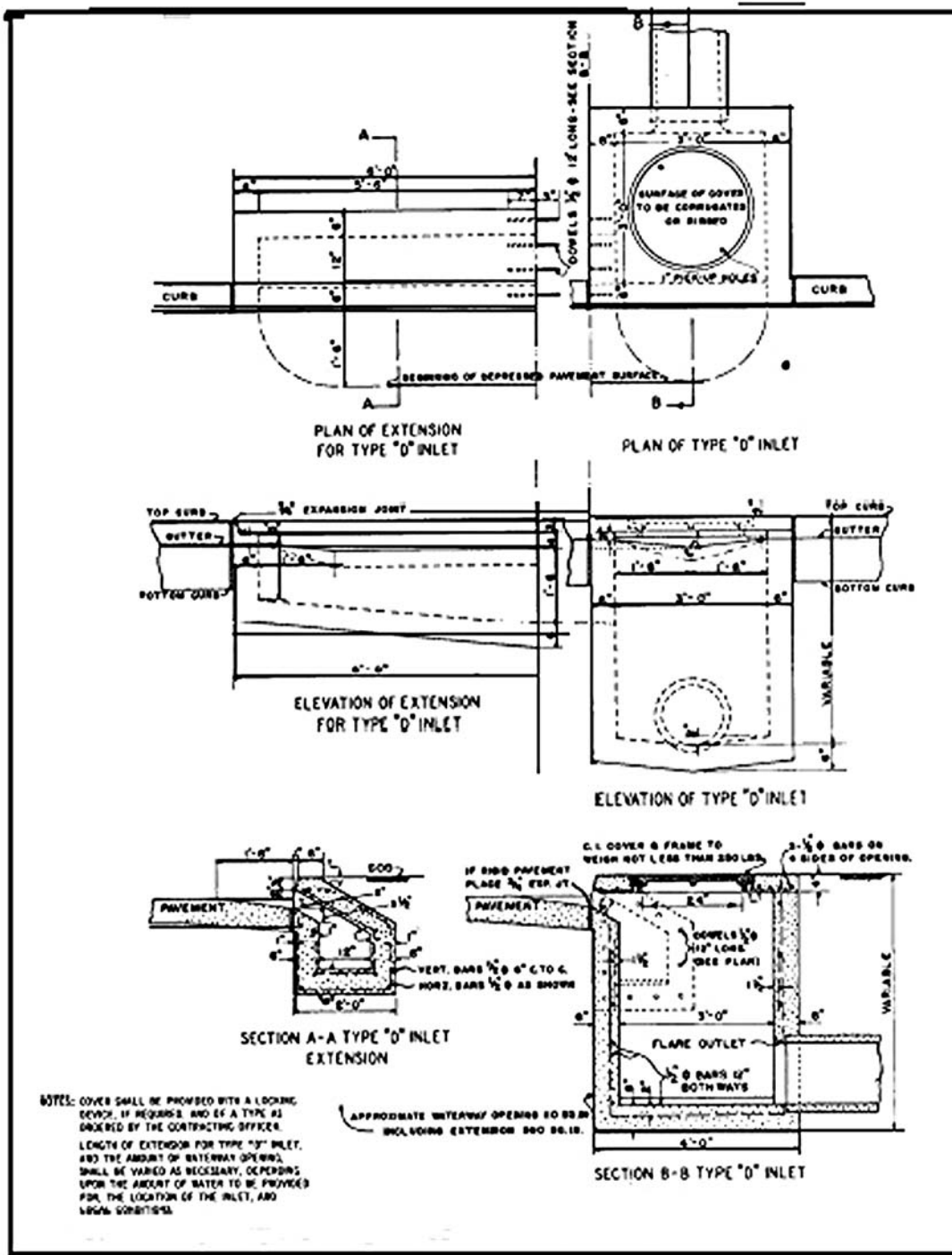

Figure 3-7
Standard Type "D" inlet

3.8 VEHICULAR SAFETY AND HYDRAULICALLY EFFICIENT DRAINAGE PRACTICE.

3.8.1 Some drainage structures are potentially hazardous and, if located in the path of an errant vehicle, can substantially increase the probability of an accident. Inlets should be flush with the ground, or should present no obstacle to a vehicle that is out of control. End structures or culverts should be placed outside the designated recovery area wherever possible. If grates are necessary to cover culvert inlets, care must be taken to design the grate so that the inlet will not clog during periods of high water. Where curb inlet systems are used, setbacks should be minimal, and grates should be designed for hydraulic efficiency and safe passage of vehicles. Hazardous channels or energy dissipating devices should be located outside the designated recovery area or adequate guard-rail protection should be provided.

3.8.2 It is necessary to emphasize that liberties should not be taken with the hydraulic design of drainage structures to make them safer unless it is clear that their function and efficiency will not be impaired by the contemplated changes. Even minor changes at culvert inlets can seriously disrupt hydraulic performance.

4. EROSION CONTROL AND RIPRAP PROTECTION

4.1 GENERAL.

4.1.1 Hydraulic structures discharging into open channels will be provided with riprap protection to prevent erosion. Two general types of channel instability can develop downstream from a culvert and storm drain outlet. The conditions are known as either gully scour or a localized erosion referred to as a scour hole. Distinction between the two conditions of scour and prediction of the type to be anticipated for a given field situation can be made by a comparison of the original or existing slope of the channel or drainage basin downstream of the outlet relative to that required for stability.

4.1.2 Gully scour is to be expected when the Froude number of flow in the channel exceeds that required for stability. It begins at a point downstream where the channel is stable and progresses upstream. If sufficient differential in elevation exists between the outlet and the section of stable channel, the outlet structure will be completely undermined. Erosion of this type may be of considerable extent depending upon the location of the stable channel section relative to that of the outlet in both the vertical and downstream directions.

4.1.3 A scour hole or localized erosion is to be expected downstream of an outlet even if the downstream channel is stable. The severity of damage to be anticipated depends upon the conditions existing or created at the outlet. In some instances, the extent of the scour hole may be insufficient to produce either instability of the embankment or structural damage to the outlet. However, in many situations flow conditions produce scour of the extent that embankment erosion as well as structural damage of the apron, end wall, and culvert are evident.

4.1.4 Empirical equations have been developed for estimating the extent of the anticipated scour hole based on knowledge of the design discharge, the culvert diameter, and the duration and Froude number of the design flow at the culvert outlet.

4.2 RIPRAP PROTECTION

4.2.1 Riprap protection should be provided adjacent to all hydraulic structures placed in erosive materials to prevent scour at the ends of the structure. The protection is required on the bed and banks for a sufficient distance to establish velocity gradients and turbulence levels at the end of the riprap approximating conditions in the natural channel. Riprap can also be used for lining the channel banks to prevent lateral erosion and undesirable meandering. Consideration should be given to providing an expansion in either or both the horizontal and vertical direction immediately downstream from hydraulic structures such as drop structures, energy dissipators, culvert outlets or other

devices in which flow can expand and dissipate its excess energy in turbulence rather than in a direct attack on the channel bottom and sides.

4.2.2 There are three ways in which riprap has been known to fail: movement of the individual stones by a combination of velocity and turbulence; movement of the natural bed material through the riprap resulting in slumping of the blanket; and undercutting and raveling of the riprap by scour at the end of the blanket. Therefore, in design, consideration must be given to selection of an adequate size stone, use of an adequately graded riprap or provision of a filter blanket, and proper treatment of the end of the riprap blanket.

4.3 SELECTION OF STONE SIZE. There are curves available for the selection of stone size required for protection as a function of the Froude number. Two curves are available, one to be used for riprap subject to direct attack or adjacent to hydraulic structures such as side inlets, confluences, and energy dissipators, where turbulence levels are high, and the other for riprap on the banks of a straight channel where flows are relatively quiet and parallel to the banks. With the depth of flow and average velocity in the channel known, the Froude number can be computed and a stone size determined from the appropriate curve. Curves for determining the riprap size required to prevent scour downstream from culvert outlets with scour holes of various depths are also available. The thickness of the riprap blanket should be equal to the longest dimension of the maximum size stone or 1.5 times the stone diameter (50 percent size), whichever is greater. When the use of very large rock is desirable but impractical, substitution of a grouted reach of smaller rock in areas of high velocities or turbulence maybe be appropriate. Grouted riprap should be followed by an ungrouted reach.

4.4 RIPRAP GRADATION. A well-graded mixture of stone sizes is preferred to a relatively uniform size of riprap. In certain locations the available material may dictate the gradation of riprap to be used. In such cases the gradation should resemble as closely as possible the recommended mixture. Consideration should be given to increasing the thickness of the riprap blanket when locality dictates the use of

gradations with larger percents of small stone than recommended. If the gradation of the available riprap is such that movement of the natural material through the riprap blanket would be likely, a filter blanket of sand, crushed rock, gravel, or synthetic cloth must be placed under the riprap. The usual blanket thickness is 6 inches, but greater thickness is sometimes necessary.

4.5 RIPRAP DESIGN. An ideal riprap design would provide a gradual reduction in riprap size until the downstream end of the blanket blends with the natural bed material. This is seldom justified. However, unless this is done, turbulence caused by the riprap is likely to develop a scour hole at the end of the riprap blanket. It is suggested that the thickness of the riprap blanket be doubled at the downstream end to protect against undercutting and unraveling. An alternative is to provide a constant-thickness rubble blanket of suitable length dipping below the natural streambed to the estimated depth of bottom scour.

5. SUBSURFACE DRAINAGE

5.1 GENERAL.

5.1.1 The water beneath the ground surface is defined as subsurface water. The free surface of this water, or the surface on which only atmospheric pressure acts, is called the groundwater table. Water is contained above an impervious stratum and hence the infiltration water is prevented from reaching a groundwater table at a lower elevation. The upper body of water is called perched groundwater and its free surface is called a perched water table.

5.1.2 This water infiltrates into the soil from surface sources, such as lakes, rivers and rainfall, and some portion eventually reaches the groundwater table. Groundwater tables rise and fall depending upon the relation between infiltration, absorption, evaporation and groundwater flow. Seasonal fluctuations are normal because of

differences in the amount of precipitation and maybe relatively large in some localities. Prolonged drought or wet periods will cause large fluctuations in the groundwater level.

5.2 SUBSURFACE DRAINAGE REQUIREMENTS. The determination of the subsurface soil properties and water condition is a prerequisite for the satisfactory design of a subsurface drainage system. Field explorations and borings made in connection with the project design should include the following investigations pertinent to subsurface drainage. A topographic map of the proposed area and the surrounding vicinity should be prepared indicating all streams, ditches, wells, and natural reservoirs. The analysis of aerial photographs of the areas selected for construction may furnish valuable information on general soil and groundwater conditions. An aerial photograph presents a graphic record of the extent, boundaries, and surface features of soil patterns occurring at the surface of the ground. The presence of vegetation, the slopes of a valley, the colorless monotony of sand plains, the farming patterns, the drainage pattern, gullies, eroded lands, and evidences of the works of man are revealed in detail by aerial photographs. The use of aerial photographs may supplement both the detail and knowledge gained in topographic survey and ground explorations. The sampling and exploratory work can be made more rapid and effective after analysis of aerial photographs has developed the general soil features. The location and depth of permanent and perched groundwater tables may be sufficiently shallow to influence the design. The season of the year and rainfall cycle will measurably affect the depth to the water table. In many locations information may be obtained from residents of the surrounding areas regarding the behavior of wells and springs and other evidences of subsurface water. The soil properties investigated for other purposes in connection with the design will supply information that can be used for the design of the drainage system. It may be necessary to supplement these explorations at locations of subsurface drainage structures and in areas where soil information is incomplete for design of the drainage system.

5.3 LABORATORY TESTS. The design of subsurface drainage structures requires a knowledge of the following soil properties of the principal soils encountered: strength,

compressibility, swell and dispersion characteristics, the in situ and compacted unit dry weights, the coefficient of permeability, the in situ water content, specific gravity, grain-size distribution, and the effective void ratio. These soil properties may be satisfactorily determined by experienced soil technicians through laboratory tests, The final selected soil properties for design purposes may be expressed as a range, one extreme representing a maximum value and the other a minimum value. The true value should be between these two extremes, but it may approach or equal one or the other, depending upon the variation within a soil stratum.

5.4 FLOW OF WATER THROUGH SOILS.

5.4.1 The flow of water through soils is expressed by Darcy's empirical law which states that the velocity of flow is directly proportional to the hydraulic gradient. This law is expressed in equation form as:

$$V = k i$$

Or

$$Q = v A = k i A$$

According to Darcy's law the velocity of flow and the quantity of discharge through a porous media are directly proportional to the hydraulic gradient. The flow must be in the laminar regime for this condition to be true.

5.4.2 A thorough discussion of the Darcy equation including the limitations, typical values of permeability, factors affecting the permeability, effects of pore fluid and temperature, void ratio, average grain size, structure and stratification, formation discontinuities, entrapped air in water or void, degree of saturation, and fine soil fraction is beyond the scope of this course, but is available in the professional literature.

5.5 DRAINAGE OF WATER FROM SOIL. The quantity of water removed by a drain will vary depending on the type of soil and location of the drain with respect to the groundwater table. All of the water contained in a given specimen cannot be removed by gravity flow since water retained as thin films adhering to the soil particles and held in the voids by capillarity will not drain. Consequently, to determine the volume of water that can be removed from a soil in a given time, the effective porosity as well as the permeability must be known. The effective porosity is defined as the ratio of the volume of the voids that can be drained under gravity flow to the total volume of soil. Limited effective porosity test data for well-graded base coarse materials, such as bank-run sands and gravels, indicate a value for effective porosity of not more than 0.15. Uniformly graded soils such as medium coarse sands, may have an effective porosity of not more than 0.25.

5.6 BACKFILL FOR SUBSURFACE DRAINS.

Placing backfill in trenches around drain pipes should serve a dual purpose: it must prevent the movement of particles of the soil being drained, and it must be pervious enough to allow free water to enter the pipe without clogging it with fine particles of soil. The material selected for backfill is called filter material. An empirical criterion for the design of filter material was proposed by Terzaghi and substantiated by tests on protective filters used in the construction of earth dams. The criterion for a filter and pipe perforations to keep protected soil particles from entering the filter or pipe significantly is based on backfill particle sizes.

APPENDIX A REFERENCES

Government Publications

Federal Specifications (Fed. Spec.)

- SS-C-1960/GEN Cement and Pozzolan, General Requirements for
- WW-P-402C Pipe, Corrugated (Aluminum Alloy)
& Notice 1 and Am-1
- WW-P-405B Pipe, Corrugated (Iron or Steel, Zinc Coated)
& Am-1

Military Standards (Mil. Std.)

- MIL-STD-619B Unified Soil Classification System for Roads,
Airfields, Embankments and Foundations
- MIL-STD-621A Test Method for Pavement Subgrade, Subbase,
& Notices 1 & 2 and Base-Course Materials

Departments of the Army, Air Force, and the Navy

- TM 5-632/AFM 91-16 Military Entomology Operational Handbook
- TM 5-785/AFM 88-29/
NAVFAC P-89 Engineering Weather Data
- TM 5-820-1/AFM 88-5,
Chap. 1 Surface Drainage Facilities for Airfields
and Heliports
- TM 5-820-2/AFM 88-5
Chap. 2 Drainage and Erosion Control: Subsurface
Drainage Facilities for Airfields
- TM 5-820-3/AFM 88-5,
Chap. 3 Drainage and Erosion-Control Structures
for Airfields and Heliports
- TM 5-852-7/AFM 88-19,
Chap. 7 Arctic and Subarctic Construction: Surface
Drainage Design for Airfields and Heliports to
Arctic and Subarctic Regions

Engineers Waterways Experiment Station, P.O. Box 631, Vicksburg, Mississippi 39180

- Technical Report H-74-9, Practical Guidance for Design of Lined Channel Expansions at Culvert Outlets

Department of Commerce

National Oceanic and Atmospheric Administration, Environmental Data and Information Center, Federal Bldg., Asheville, N.C. 28801

Generalized Estimates of Probable Maximum Precipitation and Rainfall--Frequency Data for Puerto Rico and Virgin Islands, Technical Paper No. 42, 1961

Probable Maximum Precipitation and Rainfall--Frequency Data for Alaska, Technical Paper No. 47, 1963

Rainfall Frequency Atlas of the Hawaiian Islands, Technical Paper No. 43, 1962

Rainfall Frequency Atlas of the United States, Technical Paper' No. 40, 1961

Department of Transportation

Federal Aviation Administration, M 494.3, 400 7th Street, S. W., Washington, D.C. 20590

- Airport Drainage, AC 150/5320-5B, July 1970
- Hydraulics of Bridge Waterways, J.N. Bradley, Hydraulic Design Series, No. 1, August 1960 (Revised March, 1978)

Non-Government Publications

American Association of State Highway and Transportation Officials (AASHTO), 444 N. Capital, N. W., Suite 225, Washington, D.C. 20001

- T99-81 The Moisture-Density Relations of Soils Using a 5.5-lb (2.5 kg) Ramer and a 12-in. (305 MM) Drop
- HB-12 Highway Bridges (1977, 12th Ed.; Interim Specifications 1978, 1979, 1980, 1981, 1982, 1983)

American Railway Engineering Association (AREA), 2000 L Street, N. W., Washington, D.C. 20036

- Manual for Railway Engineering (Fixed Properties) (Current to Jul 31, 1982) (Supplement 1982-1983)
- Chapter 15 Steel Structures-1981

American Society of Civil Engineers (ASCE), United Engineering Center, 345 E. 47th Street, New York, N.Y. 10017

- Manuals and Reports on Engineering Practice
No. 37 Design and Construction of Sanitary and Storm Sewers, 1969 (Reprinted 1974)

APPENDIX B

NOTATION

A	Drainage area, acres, total area of clear opening, or cross-sectional area of flow, ft ² .
AHW	Allowable headwater depth, ft.
B	Width, ft.
C	Coefficient.
D	Height of culvert barrel, ft.
d	Depth or thickness of grate, ft.
d _c	Critical depth, ft.
F	Infiltration rate, in/hr.
g	Acceleration due to gravity, ft/sec ² .
H	Depth of water, ft.
H _f	Headloss due to friction, ft.
HW	Headwater, ft.
h ₀	Distance from culvert invert at the outlet to the control elevation, ft.
I	Rainfall intensity, in/hr.
i	Hydraulic gradient.
K	Constant.
K _s	Coefficient.
k	Coefficient of permeability.
L	Length of slot or gross perimeter of grate opening, or length, ft.
L _a	Adjusted length, ft.
L _s	Length of spiral, ft. (nonsuperelevated channel).
L _u	Length of spiral, ft. (superelevated channels).
n	Manning's roughness coefficient.
Q	Discharge or peak rate of runoff, cfs.
R	Hydraulic radius, ft.
R _c	Radius of curvature center line of channel, ft.
S	Slope of energy gradient, ft/ft.
S ₀	Slope of flow line, ft/ft.
T	Top width at water surface, ft.
TW	Tailwater, ft.
V	Mean velocity of flow, ft/sec.
v	Discharge velocity in Darcy's law, ft/sec.
y	Depth of water, ft.

APPENDIX C

BIBLIOGRAPHY

- A Policy on Design of Urban Highways and Arterial Streets*, American Association of State Highway Officials, 1973.
- Baker, R. F., Byrd, L. G., and Mickle, D. E., *Handbook of Highway Engineering*, New York: Van Nostrand-Reinhold, 1974.
- Concrete Pipe Design Manual, American Concrete Pipe Association, 1974.
- Handbook of Drainage and Construction Products, Armeo Drainage and Metal Products, Inc., Ohio, 1967.
- Handbook of Steel Drainage and Highway Construction Products, American Iron and Steel Institute, New York, 1971.
- King, H. W., and Brater, E. E., *Handbook of Hydraulics*, McGraw-Hill Book Company, Inc., New York, N.Y., 1963.
- Morris, H. M., and Wiggert, J. M., *Applied Hydraulics in Engineering*, 2nd Edition, New York: Ronald Press Company, 1971.
- Paguette, R. J., Ashford, N., and Wright, P. H., *Transportation Engineering*, New York: Ronald Press Company, 1972.
- Ritter, L. J., Jr., and Paquette, R. J., *Highway Engineering*, New York: Ronald Press Company, 1967.
- Sewer Manual For Corrugated Steel Pipe, National Corrugated Steel Pipe Association, Illinois, 1978.
- Silberman, E., and Dahlin, W. Q., *Friction Factors for Helical Corrugated Aluminum Pipe*, Project Report No. 112, University of Minnesota, St. Anthony Falls Hydraulic Laboratory, 1969.
- Stevens, M. A., Simmons, D. E., and Watts, F. J., *Riprapped Basins for Culvert Outlets*, Highway Research Record, No. 373, 1971.
- U.S. Department of Agriculture, *Friction Factors for Helical Corrugated Pipe*, by C. E. Rice, ARS 41-119, 1966.
- U.S. Army Engineer Waterways Experiment Station, *Erosion and Riprap Requirements at Culvert and Stem-Drain Outlets*, by J. P. Bohan, Research Report H-70-2, 1970.
- U.S. Army Engineer Waterways Experiment Station, *Evaluation of Three Energy Dissipators for Stem-Drain Outlets*, by J. L. Grace and G. A. Pickering, Research Report H-71-1, 1971.
- U.S. Army Engineer Waterways Experiment Station, *Practical Guidance for Estimating and Controlling Erosion at Culvert Outlets*, by B. P. Fletcher and J. L. Grace, Jr., Miscellaneous Paper H-72-5, 1972.
- U.S. Department of the Interior, Bureau of Reclamation, *Hydraulic Design of Stilling Basin for Pipe or Channel Outlets*, by G. L. Belckley, Research Report No. 24, 1971.
- U.S. Department of Transportation, Federal Highway Administration, *Hydraulic Design of Improved Inlets for Culverts*, Hydraulic Engineering Circular No. 13, August 1972.

Viessman, W., Jr., Knapp, J. W., Lewis, G. L., and Harbaugh, T. E., *Introduction to Hydrology*, 2nd Edition, New York: TEP, 1977.

Yen, B. C., and Ying-Chang Liew, *Hydraulic Resistance in Alluvial Channels*, Research Report No. 22, University of Illinois Water Research Center, Urbana, Illinois, 1969.