



PDHonline Course C576 (2 PDH)

An Introduction to Distillation and Condensation Techniques for Water Desalination

Instructor: J. Paul Guyer, P.E., R.A., Fellow ASCE, Fellow AEI

2020

PDH Online | PDH Center

5272 Meadow Estates Drive
Fairfax, VA 22030-6658
Phone: 703-988-0088
www.PDHonline.com

An Approved Continuing Education Provider

An Introduction to Distillation and Condensation Techniques For Water Desalination

J. Paul Guyer, P.E., R.A., Fellow ASCE, Fellow AEI

CONTENTS

1. SITE SELECTION
2. WATER SOURCE SELECTION
3. GENERAL PROCESS SELECTION
4. DISTILLATION/CONDENSATION TECHNIQUES

This course is adapted from the *Unified Facilities Criteria* of the United States government, which is in the public domain, is authorized for unlimited distribution, and is not copyrighted.

The Figures, Tables and Symbols in this document are in some cases a little difficult to read, but they are the best available. **DO NOT PURCHASE THIS COURSE IF THE FIGURES, TABLES AND SYMBOLS ARE NOT ACCEPTABLE TO YOU.**

1. SITE SELECTION

1.1 SITE TECHNICAL REQUIREMENTS. Site technical requirements are specific to each particular process. Generalized recommendations can be made regarding location, space, and access requirements. A typical desalination system flowsheet is shown in figure 3-1. A typical desalination system layout, using reverse osmosis as a sample process, is shown in figure 3-2.

1.1.1 LOCATION. Desalination facilities will be located as close to the raw water source as possible in order to avoid excessive pipeline or pumping costs and to minimize operation and maintenance costs for pumping raw water (high saline content). Topography should be considered in the siting of a desalination facility, and gravity flow should be used where possible.

1.1.2 SPACE REQUIREMENTS. The space required for desalination facilities is determined by the process. Membrane desalination equipment needs less space than distillation/ condensation desalination equipment. In general, space requirements are less for the desalination equipment than for a conventional surface water treatment plant of the same capacity. An exception is solar desalination systems. These systems employ solar collectors that require an area several times greater than other types of desalination equipment in order to achieve equal capacity.

1.1.3 ACCESS. Access to systems must be provided to permit routine maintenance, sludge and brine removal, and delivery of desalination equipment and supplies. The access requirements for desalination facilities are similar to those for conventional water treatment facilities.

1.2 WATER STORAGE AND SYSTEM MODULARIZATION.

1.2.1 EQUIPMENT DOWNTIME. In all distillation/ condensation and many membrane desalination plants, storage will be determined by equipment downtime when equipment downtime is more than 1 day. To determine the necessary storage, establish the longest period of time that could be required for planned or unplanned maintenance. Calculate the storage by multiplying this time period by the water demand rate.

1.2.2 PEAK DAILY DEMANDS. When maximum equipment downtime is less than 1 day, the peak daily demands may set a larger storage demand.

1.2.3 FIRE WATER STORAGE. On a facility served by a desalination system, fire water may be saline water or potable water depending on economic analysis. Dual water distribution system will be required if saline water is used. Hence, part of the fire protection water can be either saline or potable water due to piping and pumping cost. Economic evaluation of various design alternatives is usually needed to assure the optimal design to be adopted.

1.2.4 SYSTEM REDUNDANCY AND MODULARIZATION. One complete and functional desalination module in excess of that required to supply the design flow will be provided as redundant capacity, and all desalination systems will have a minimum of three independently functioning desalination modules where practicable.

2. WATER SOURCE SELECTION

2.1 GENERAL. The selection of a water supply will be based on available quantity, quality, and cost of development. Investigate usable fresh surface water and groundwater thoroughly, prior to consideration of sources requiring desalination. When fresh water sources do not exist, consider saline water sources. The most commonly used parameter to differentiate between saline water qualities is total dissolved solids (TDS). The total dissolved solid is defined as the sum of the dissolved organic materials and the inorganic salts. Fresh waters contain less than 1,000 milligrams per liter of total dissolved solids. Brackish water contains 1,000-20,000 milligrams per liter of

total dissolved solids. Sea water usually contains at least 20,000 milligrams per liter of total dissolved solids. Quantities of potable water needed will be determined by an analysis of the site.

2.2 QUALITY. The quality will be determined by the planned use. Physical, chemical, and bacteriological testing of source waters are required to determine the level of treatment to supply the necessary water quality. When the quantity withdrawn exceeds the recharge rate, quality inherently decreases; therefore, this must be considered during design.

2.2.1 PHYSICAL CHARACTERISTICS. The physical characteristics of the raw water source that must be evaluated are total suspended solids (TSS), temperature, turbidity and silt density index (SDI).

2.2.1.1 TOTAL SUSPENDED SOLIDS. The total suspended solids level of raw water sources must be evaluated to determine the level of pretreatment processes required. Raw water having low total suspended solids levels generally requires less pretreatment. The source with the lowest total suspended solids is preferred.

2.2.1.2 TEMPERATURE. The temperature of the raw water source must be matched to the specific desalination process. In extreme cases, the water temperature may control the desalination process selection. A climatological survey must be made prior to finalization of process selection to determine the seasonal maximum and minimum water temperatures of the proposed water sources.

2.2.1.3 TURBIDITY AND SILT DENSITY INDEX. These two characteristics provide two different measures of the amount of fine particulate matter in the water. Turbidity is measured in nephelometric turbidity units (a measure of the amount of light scattered by a known water sample thickness). Silt density index is a measure of the amount of 0.45-micron filter plugging caused by passing a sample of water through the filter for 15 minutes. Turbidity must be determined for all desalination processes. Also, the silt density index must be determined for water being considered for reverse osmosis treatment.

2.2.2 CHEMICAL CONSTITUENTS. The chemical constituents of the raw water must be determined to provide information for treatment selection. Table 2-1 shows the water testing analyses required for desalination treatment.

2.2.3 BACTERIOLOGICAL QUALITY. The bacteriological testing of the raw water must include a type of a coliform indicator organism count. Procedures for filter membrane, most probable number fermentation tube, and standard plate count, coliform organism bacteriological testing techniques can be found in the professional literature. Manufacturers' recommendations as to the media and procedures used to identify microbiological activity detrimental to the operation of a particular desalination system shall be followed.

2.3 SELECTION VERSUS REJECTION OF POTENTIAL RAW WATER SOURCES.

After the completion of physical, chemical, and bacteriological testing, a final water source may be selected. Extreme care must be taken in the selection of a source where the usage rate is greater than the recharge rate. In most cases, selection will involve choosing the brackish water with the lowest level of total dissolved solids. When brackish water is not available, use sea water or water as saline as sea water as the feed water source. When the coliform indicator organism count of a water is greater than 10,000 most probable number (MPN), then the water source should be rejected for sanitary reasons and a more saline water chosen (per Standard Methods for the Examination of Water and Wastewater). If other water is available, water containing more than 1,000 nephelometric turbidity units should be rejected on the basis of the high cost and difficulty of clarification, even if the alternative water is more saline. When the total delivery pumping pressure of a less saline water is greater than the operating pressure of a reverse osmosis system, then the desalination of the more saline water by reverse osmosis may be more economical than the combined cost of delivery and desalination of the less saline source. The final selection of a raw water source will be based on economic studies. In some cases, the decision cannot be made until all systems are fully designed and life cycle costed.

WATER TESTING REQUIRED FOR DESALINATION TREATMENT

TEST	PROCESS		
	<i>Electrodialysis Reversal</i>	<i>Reverse Osmosis</i>	<i>Distillation</i>
TDS	O-P	O-P	D-P
Temperature	O	O	D
Turbidity	O-P	O-P	D-P
Suspended Solids	P	P	P
Color	O-P	O-P	D-P
Corrosivity	O	O	D
Odor	P	P	P
pH	O-P	O-P	D-P
Alkalinity	O-P	O-P	D-P
Total Hardness	O-P	O-P	D-P
Noncarbonate Hardness	O-P	O-P	D-P
Carbonate Hardness	O-P	O-P	D-P
H ₂ O	O	O	D
Chlorine Demand	O	O	D
Bacterial Contamination	O-P	O-P	D-P
Plankton	O	O	D
Oil and Grease	O	O	D
Endrin	O-P	O-P	D-P
Lindane	O-P	O-P	D-P
Methoxychlor	O-P	O-P	D-P
Toxaphene	O-P	O-P	D-P
2, 4-D	O-P	O-P	D-P
2, 4, 5-TP Silvex	O-P	O-P	D-P
Trihalomethanes	P	P	P
Ammonia	O-P	O-P	D-P
Arsenic	O-P	O-P	D-P
Barium	O-P	O-P	D-P
Cadmium	O-P	O-P	D-P
Chromium	O-P	O-P	D-P
Lead	O-P	O-P	D-P
Mercury	O-P	O-P	D-P
Nitrate	O-P	O-P	D-P
Selenium	O-P	O-P	D-P
Silver	O-P	O-P	D-P
Fluoride	O-P	O-P	D-P
Zinc	O-P	O-P	D-P
Copper	O-P	O-P	D-P
Boron	O-P	O-P	D-P
Calcium	O-P	O-P	D-P
Magnesium	O	O	D
Strontium	O	O	D
Sodium	O	O	D
Potassium	O	O	D
Bicarbonate	O	O	D
Carbonate	O	O	D
Sulfate	O-P	O-P	D-P
Chloride	O-P	O-P	D-P
Iron	O-P	O-P	D-P
Manganese	OP	O-P	D-P
Molybdenum Reactive Silica		O	
Molybdenum Nonreactive Silica		O	
Silt Density Index		O	

Legend:

- D = Required for desalination process design
- P = Required for potable water design

Table 2-1

Water Testing Required for Desalination Treatment

3. GENERAL PROCESS SELECTION

In selecting a potable water production system, it is important to estimate costs of various options. The conventional unit of comparison is cost in dollars per 1,000 gallons of product water. Water quality and energy sources will be estimated from simple site reconnaissance. For example, a sea coast site where the water source temperature exceeds 95 degrees Fahrenheit indicates a high-salinity high-temperature combination favoring distillation/ condensation processes. Reverse osmosis requires a feed water temperature below 95 degrees Fahrenheit. If local well testing indicates salinity between 500 and 3,000 milligrams per liter and electricity is inexpensive, electro dialysis reversal or highflux reverse osmosis is indicated.

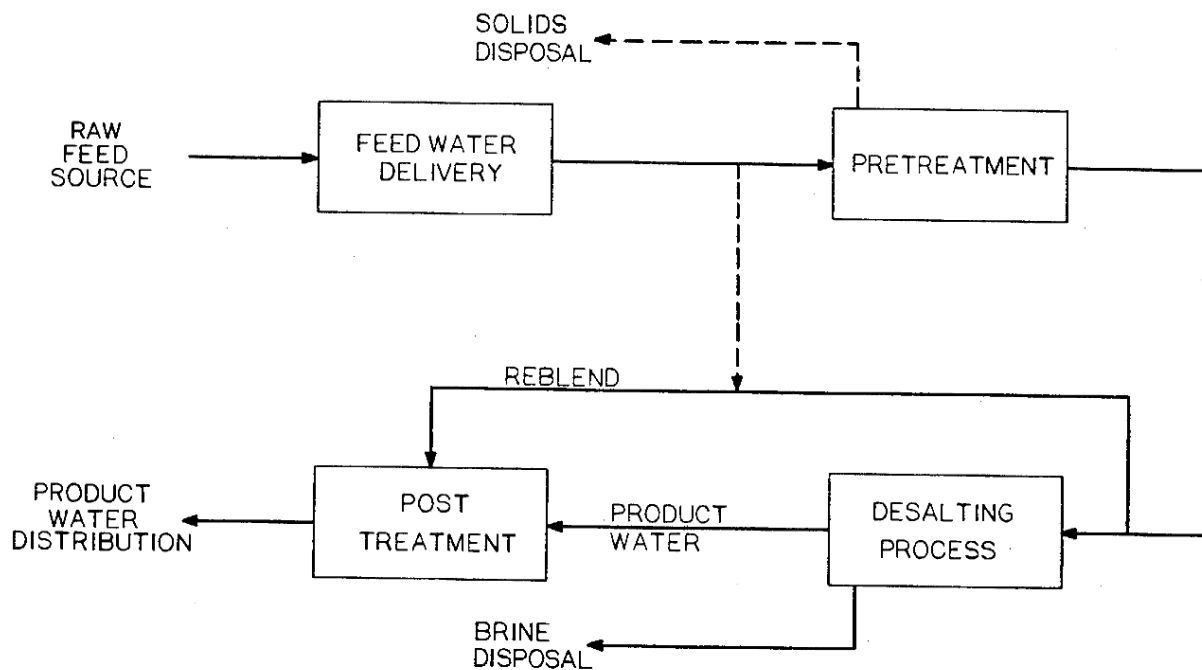

Figure 3-1
Typical desalination flowsheet

3.1 DESALINATION REQUIREMENTS. The design of a desalination system requires a clear understanding of the following: the quantity of product water desired; the quality of the desired product; and the quality of the feed water source. This course addresses the production of potable water containing less than 500 milligrams per liter of total dissolved solids. Laundries, boilers, mess halls, and hospitals may require water purer than 500 milligrams per liter of total dissolved solids. Potable water from the desalination system may be further treated to meet these requirements.

3.2 SALINE FEED WATER QUANTITY. The production of potable water from saline water usually requires a significantly larger quantity of saline feed water than the quantity of potable water produced. When desalination is necessary to produce potable water, the process splits the feed water into two streams. One stream is the product water; the other stream is the brine that contains most of the salts originally in the feed water. In waters that need very little desalination, high-rate reverse osmosis may only reject 5 percent of the feed stream as brine. In reverse osmosis of sea water, more than 70 percent of the intake water may be rejected as brine. Multiply the required product quantity by the reciprocal of the product water recovery fraction to find the quantity of saline water that must be processed to yield the desired quantity of product water. In equation form it can be expressed as:

$$100\% \text{ recovery of product water} \times \text{water demand} = \text{saline feed water flow}$$

In some cases, the limited quantity of available saline water may require a decision to adopt a more expensive desalination process with a higher water recovery rate. However, it may require choosing a different and more saline feed water with a greater availability.

3.3 BLENDING OF WATERS. Blending a high concentration stream with a low concentration stream wastes the osmotic pressure energy between the two streams. Therefore, it is best to match the design of the desalination system to the product quality desired. When a desalination process cannot be economically matched to the desired

product quality, then a process that yields water with a very low dissolved material content must be used. To conserve capital and equipment costs and meet the desired water demand, the high purity product water can be blended with the pretreated saline feed water to produce the required product quantity and quality. The following equation can be used to calculate the concentration of a blended water stream:

$$\left(\sum_{i=1}^{i=n} \text{concentration } i \times \text{flow } i \right) / \text{total flow} = \text{blended concentration}$$

When only two streams are blended, the equation can be rearranged to show the flow of concentrated water that when blended with a dilute flow will result in the desired product concentration. This rearranged equation is as follows:

$$[(P - H)(D)]/(C - P) = F$$

Where:

P = Desired product water concentration

H = High purity water concentration

D = Flow of the high purity water

C = Concentration in the impure concentrated stream

F = Flow rate of the concentrated stream

The same blend equations will apply to blending for remineralization, which is a more common procedure.

3.4 PROCESS LIMITATIONS. The various desalination processes presently available have limitations that must be considered prior to selecting a desalination process for a particular site. These limitations apply only to the desalination processes themselves; pretreatment can be and is often used to bring a saline feed water within limits so that a desalination process can be used. The raw feed water chemistry for all desalination systems must be evaluated thoroughly for constituents that may precipitate in the desalination system.

3.4.1 HIGH-TEMPERATURE DISTILLATION. High-temperature distillation is limited by the saturation of alkaline earth metal salts, such as CaSO_4 , BaSO_4 , SrSO_4 , CaCO_3 , BaCO_3 , and SrCO_3 . Carbonate salt scaling can be controlled by acid addition. The recovery of water from a high-temperature distillation plant is usually limited by calcium sulfate solubility. When the concentration of the sulfate and the limiting alkaline earth metal is one-third of the saturated condition at ambient temperature, distillation design must include pretreatment to reduce or inhibit the scaling ions. High-temperature distillation is also limited to oil and grease levels below 1 milligram per liter. All other limitations on the high-temperature distillation process are equipment specific and require individual evaluation.

3.4.2 LOW-TEMPERATURE AND MECHANICAL DISTILLATION. Low-temperature and mechanical distillation systems are limited to operation below saturation of alkaline earth sulfates and carbonates. The lower operating temperature permits economical operation on waters that are at or below half saturation at ambient temperature. Oil and grease are limited to less than 1 milligram per liter. Any other limitations are equipment specific.

3.4.3 REVERSE OSMOSIS. The most severe limitation on reverse osmosis is the maximum limit of 50,000 milligrams per liter of total dissolved solids in the feed water. Another limitation is that there must be no iron in the feed water. This limitation is so rigid that only stainless steel and non-ferric materials will be used downstream of the iron removal. The solubility of alkaline earth sulfates and carbonates limits reverse osmosis treatment. Any water containing less than 4,000 milligrams per liter of total dissolved solids that would be saturated with an alkaline earth sulfate when the concentration is multiplied by 1.5 should not be considered for reverse osmosis desalination. Reverse osmosis is limited to waters that do not have silica saturation in the reject brine. Silica chemistry is extremely complex. When the molybdenum reactive silica concentration exceeds 30 milligrams per liter as SiO_2 or the pH exceeds 8.3 in the brine stream, an environmental chemist or engineer should be consulted. Reverse

osmosis is also limited to the treatment of waters with less than 1 milligram per liter of oil and grease.

3.4.3.1 CELLULOSE ACETATE MEMBRANES. Cellulose acetate membranes are usually limited to pH levels between 4.0 and 7.5. Cellulose acetate membranes require some form of continuous disinfection with the feed water to prevent microbial degradation of the membranes and can tolerate up to 1 milligram per liter of free chlorine. Therefore, cellulose acetate membranes are usually disinfected by maintaining 0.2 to 0.9 milligrams per liter of free chlorine in the feed water. Cellulose acetate membranes cannot be used on waters where the temperature exceeds 88 degrees Fahrenheit. Cellulose acetate membranes should not be used at pressures greater than the manufacturer's recommended pressure, since they are prone to membrane degradation by pressure compaction.

3.4.3.2 POLYAROMATIC AMIDE MEMBRANES. Brackish water polyaromatic amide membranes are generally limited to operation in feed waters between pH 4 and pH 11. Polyaromatic amide membranes are less pH tolerant and should not be used outside of the range pH 5 to pH 9. All polyaromatic amide membranes are limited to use on feed streams that are free of residual chlorine. If chlorination is necessary or desirable as a pretreatment option, complete dechlorination must be effected. Polyaromatic amide membranes are tolerant of water temperatures up to 95 degrees Fahrenheit. While polyaromatic amide membranes are not as quickly or completely compacted as are cellulose acetate membranes, manufacturer's recommended pressures must be followed to prevent mechanical damage to membrane modules.

3.4.3 ELECTRODIALYSIS REVERSAL. While electro dialysis reversal has been used to treat water as saline as sea water, 4,000 milligrams per liter of total dissolved solids is considered to be an upper limit for economical operation. Some electro dialysis membranes can tolerate strong oxidants, like chlorine, but most cannot. The reversal of polarity used in electro dialysis reversal for removal of scale allows operation on water that is saturated with alkaline earth carbonates. Saturation with an alkaline sulfate with low carbonate alkalinity should be avoided.

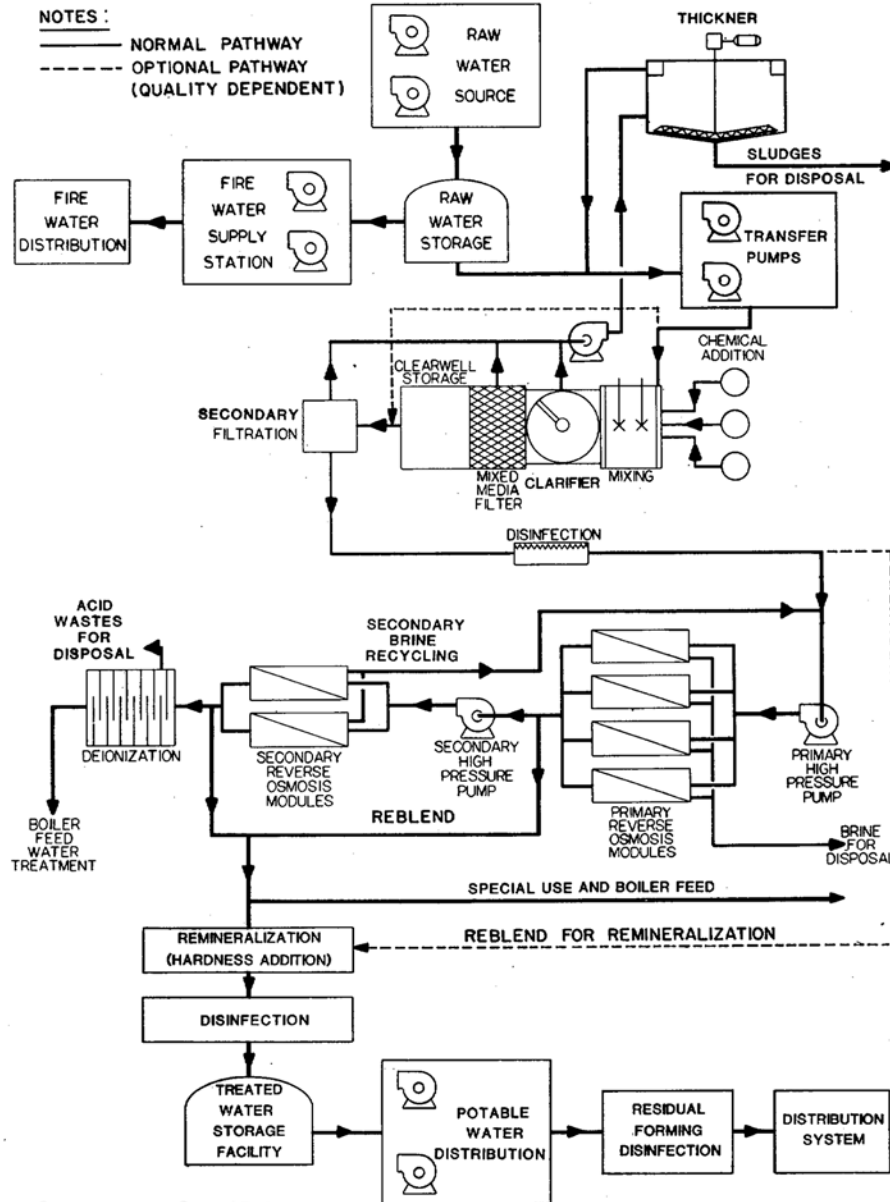

Figure 3-2

Typical reverse osmosis desalination system

3.3 DISTILLATION/CONDENSATION ENERGY. In distillation/condensation plants, energy is used in the form of steam and electricity. Steam is used to heat the saline water to increase its vapor pressure. Normally, electricity is used to run the compressor in vapor compression distillation. If excess steam is available, its use as a power source should be

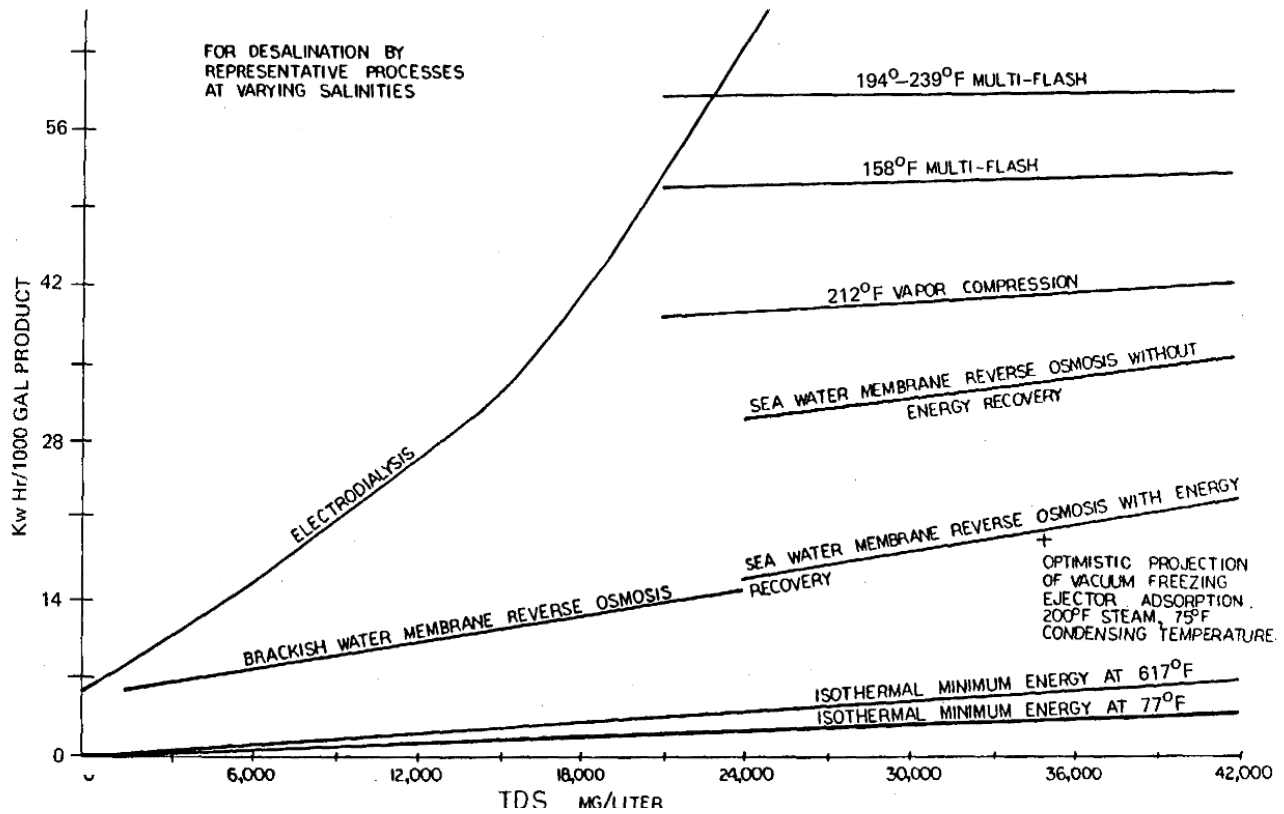

Figure 3-3
Energy Consumption

investigated. The amount of electricity or mechanical work that steam will yield depends on its temperature as well as the temperature to which it can be condensed. The energy consumption of both vapor compression and thermal distillation, as related to the total dissolved solids of feed water, is shown in figure 3-3.

RULE	A	B	C	D	D	E
	If the freshest source of water is:	And if the desired output water will be:	And if electricity is to be generated:	And if the projected cost ratio of 264 deg F steam/electricity:	Then investigate the cost of:	And have the following tests performed:
1	More salty than sea water	Potable water			Transportation of fresher water; distillation can be used but at great expense	Total Dissolved Solids (TDS)
2	Sea water	High-pressure boiler feed water	By steam turbine		Distillation followed by ion exchange	TDS, Ca, SO ₄ , CO ₃ , pH
3	Sea water	Potable water	By steam turbine	Greater than 10 ⁷ BTU/kwh	Thermal distillation either with or without vapor compression	TDS, Ca, SO ₄ , CO ₃ , pH
4	Sea water	Potable water	By internal combustion engine		Vapor compression distillation and waste heat	TDS, bacterial count, turbidity
5	Sea water	Potable water	no	Less than 10 ⁷ BTU/kwh	Reverse osmosis	TDS, Ca, SO ₄ , CO ₃ , pH, bacterial count, silt density index, turbidity, oil & grease
6	Brackish water	Potable water			Reverse osmosis	TDS, Ca, SO ₄ , CO ₃ , pH, bacterial count, silt density index, turbidity, oil & grease
7	Slightly saline brackish water	Potable water			Electrodialysis reversal	TDS, full ionic breakdown, bacterial count, turbidity

Table 3-1
Preliminary desalination process selection

3.4 MEMBRANE ENERGY. Historically, membrane desalination systems use less energy than other systems. Brackish water desalination should be accomplished by membrane separation processes because of the reduced energy requirement. The energy consumption of electrodialysis reversal can be made to follow reduced or variable salinity, while the energy consumption of reverse osmosis is set principally by membrane water flux. Again, the energy consumption of electrodialysis reversal and reverse osmosis as a function of the total dissolved solids content of the feed water is shown in figure 3-3. As membrane materials are developed, energy consumption may be reduced.

3.5 WASTE DISPOSAL. Waste disposal may influence process selection. Since brine disposal costs can be an important part of process economics, brine disposal alternatives must be explored while water quality analyses are being performed.

3.6 PRELIMINARY PROCESS SELECTION. Use preliminary site information to eliminate certain desalination processes. A decision logic table for use with preliminary information is shown in table 3-1. Decisions based upon table 3-1 are to be considered preliminary only. Necessary water quality tests to further support the recommendations made in Column E of table 3-1 are in Column F.

3.7 PROCESS SELECTION. When initial site and raw water source selections have been made, use preliminary water quality information with table 3-1 to assist in a preliminary process selection. As more specific information is obtained from laboratory analyses of water quality, make an initial process selection using the second decision logic table, table 3-2. After a treatability investigation has been completed, select the final desalination process. The use of the decision logic table sequence will only provide generalized assistance in process selection; additional economic, engineering, and environmental studies may indicate that methods or combinations of methods must be used.

Rule	A	B	C	D	E	F
	If the feedwater TDS is (mg/liter):	And if the raw feed water suspended solids are:	And if the product of $(Ca)(SO_4)$ moles ² /liter ² in the reject brine is:	And if the oil and grease in the raw feedwater is:	Then investigate the cost of:	And have the following pretreatment processes investigated for effectiveness:
1	Greater than 50,000				Transportation of fresher water. Distillation of this water is extremely expensive.	Precipitation of less soluble salts
2	Between 20,000 and 50,000	Over 20 NTU	Considerably less than 2×10^{-4}	Greater than 10 mg/liter	Reverse osmosis or distillation and steam and electricity	Alum jar tests, pH adjustment, 10 micron or smaller filter plugging
3	Between 20,000 and 50,000	Over 1 NTU		Less than 10 mg/liter	Reverse osmosis	Alum jar tests, 10 micron or smaller filter plugging, UV sterilization
4	Between 20,000 and 50,000	Less than 1 NTU; SDI greater than 3		Less than 10 mg/liter	Spiral-wound membrane reverse osmosis	pH adjustment, UV sterilization, chlorine disinfection, chlorine residual
5	Between 20,000 and 50,000	SDI under 3		Less than 10 mg/liter	Hollow fine-fiber membrane reverse osmosis	10 micron or smaller filter test; UV sterilization
6	Between 3,000 and 20,000	Over 1,000 mg/liter	Considerably less than 2×10^{-4}	Greater than 10 mg/liter	Distillation	pH adjustment, alum jar test
7	Between 3,000 and 20,000			Less than 10 mg/liter	Reverse osmosis	pH adjustment, alum jar test, silt density index, UV sterilization
8	Between 500 and 4,000				Electrodialysis reversal	pH adjustment, alum jar test, 10 micron filter plugging, chlorine disinfection

Table 3-2

Selecting desalination processes after water quality data are obtained

4. DISTILLATION/CONDENSATION TECHNIQUES

4.1 GENERAL. Distillation/condensation is the most common desalination process. More than 70 percent of all desalination facilities in use today employ some variation of the distillation/condensation process.

4.2 HIGH-TEMPERATURE DISTILLATION. High temperature distillation facilities that operate at temperatures greater than 205 degrees Fahrenheit are the most prevalent

desalination facilities in the world today. There are three methods of vaporization: submerged tube vaporization; flash vaporization; and thin-film vaporization. These methods are illustrated in figure 4-1. Submerged tube vaporization is the least efficient vaporization technique, but it allows for easy maintenance. This type of vaporization system is most often used in exhaust gas waste heat recovery distillation systems. The flash vaporization technique is presently the most common technique in existing distillation units. The impact of sprayed hot brine within the evaporator unit causes both erosion and corrosion of most metals. Using a thin-film spray vaporization process, the raw water is introduced at slightly less than atmospheric pressure through an orifice onto heat exchanger tubes for immediate vaporization. The corrosive environment is reduced from the flash vaporization system, but scaling can occur on the heat transfer surfaces. These vaporization techniques are used in the two major high-temperature distillation processes, multiple-effect (ME) evaporation, and multistage flash (MSF) evaporation.

4.2.1 MULTIPLE-EFFECT EVAPORATION UNITS. To maximize thermal energy efficiency within a distillation/condensation system, several units or effects are used. The heat from the condensation step of one effect is used to supply vaporization heat for the following effect. The next effect is a slightly lowered pressure and temperature. This gradual reduction by heat transfer results in a much greater yield of product water from a given quantity of thermal energy. A typical multiple-effect evaporation unit is shown in figure 4-2.

4.2.2 MULTISTAGE FLASH-EVAPORATION UNITS. Distillation technology was advanced through the development of multistage flash evaporation units. Stages of flash evaporation are operated using heat from an external source. Pressure is reduced gradually in each successive stage to continue flash operation at successively lower temperatures and pressures. Because scaling is not a serious problem, this design has become the most prevalent distillation process. A typical multistage flash-evaporation unit is shown in 4-3. Although internal scaling is not a great problem, corrosion of flash-evaporation units is of concern.

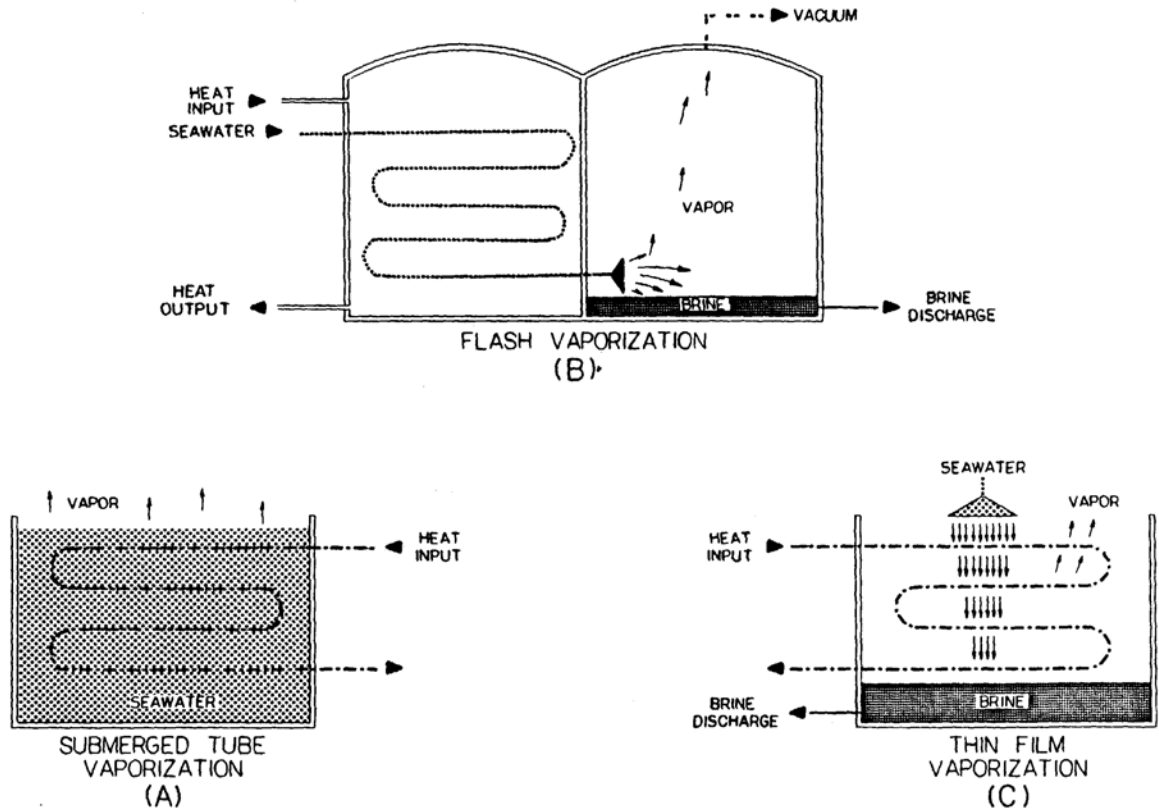

Figure 4-1

Three methods of vaporization

4.3 LOW-TEMPERATURE DISTILLATION. Distillation/ condensation facilities that operate at temperatures less than 205 degrees Fahrenheit are low-temperature units. In situations where waste heat is plentiful, low temperature waste-heat-recovery evaporation units are used. A waste-heat-recovery unit is shown in 4-4. For onshore application, low-pressure waste steam from power generation facilities can provide the necessary thermal energy for desalination systems. The most recent developments in distillation/condensation technology involve the use of waste heat or low pressure steam with evaporation units and a mechanical vapor compression system. Multiple stages then derive the maximum vapor and product water production from the system.

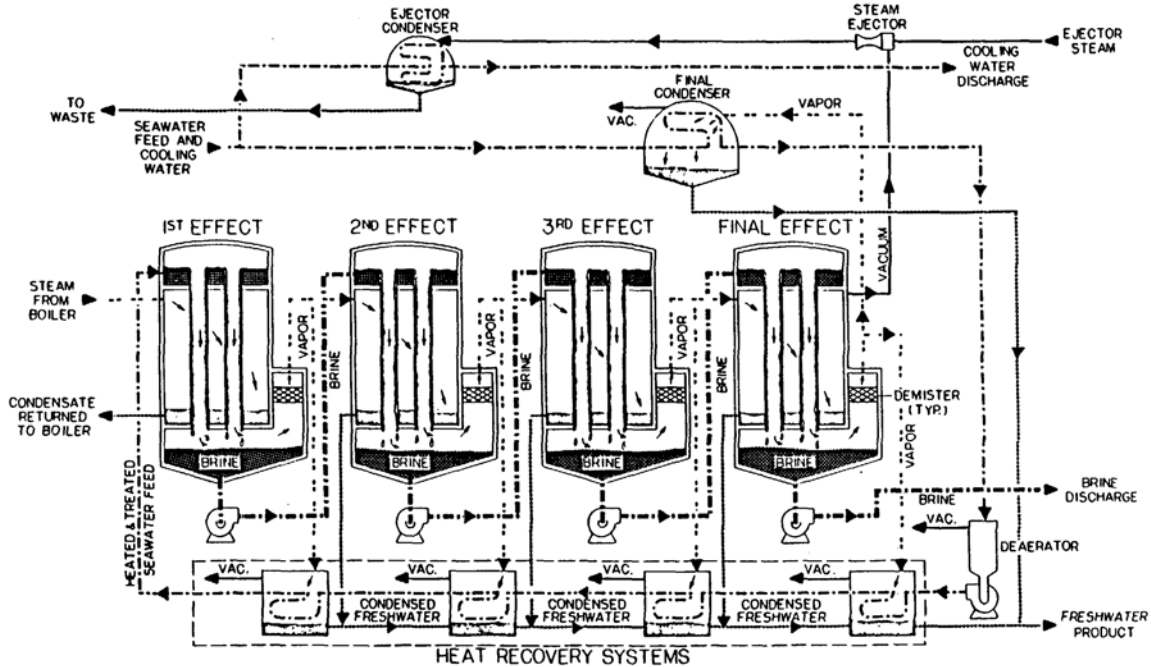

Figure 4-2

Multiple-effect vertical-tube evaporation process.

4.4 MECHANICAL DISTILLATION. The use of mechanical methods for vapor production and heat transfer can result in a highly efficient desalination system. These systems operate at temperatures less than atmospheric boiling point and use a variety of methods to vaporize raw waters. These mechanical processes commonly use multiple effects to maximize the efficiency of the applied mechanical energy.

4.4.1 VAPOR COMPRESSION. The technique of vapor compression uses a mechanical energy source, such as an engine or electric motor, to power a compression turbine. This turbine draws vapor from the distillation vessel and compresses it, which raises the temperature of the exhaust vapor. The vapor is then passed over a heat exchanging condenser, where it returns to the liquid state as product water. The heat removed during condensation is returned to the raw water to assist in the production of more vapor. The more recent vapor compression multiple-effect units produce a

concentrated brine byproduct that has had its excess heat reduced by the multiple effects.

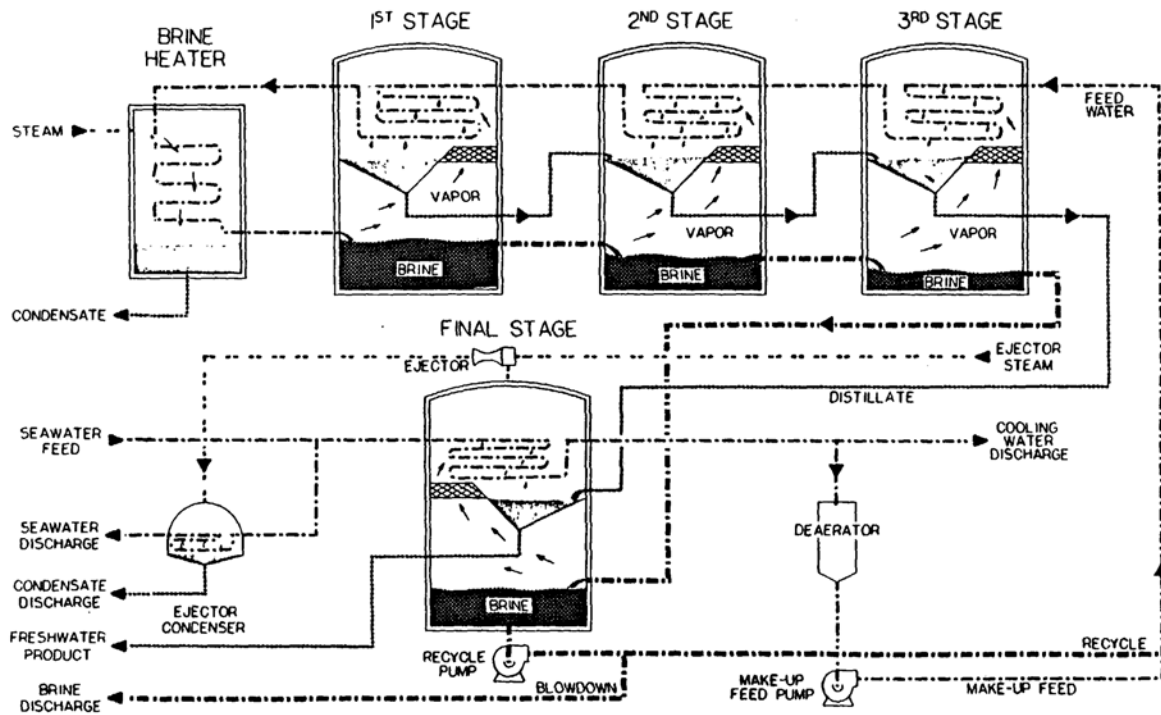

Figure 4-3
Multistage flash distillation facility.

4.4.2 WASTE HEAT. Adding waste heat to vapor compression systems results in a highly efficient distillation/condensation process. These systems are designed to maximize the production of product water with minimal energy input. A typical vapor-compression multiple-effect system is shown in figure 4-5.

The advantages of this type of system include a lower energy demand than high-temperature distillation, less corrosion due to possible use of thermoplastic materials, and lower operational temperatures.

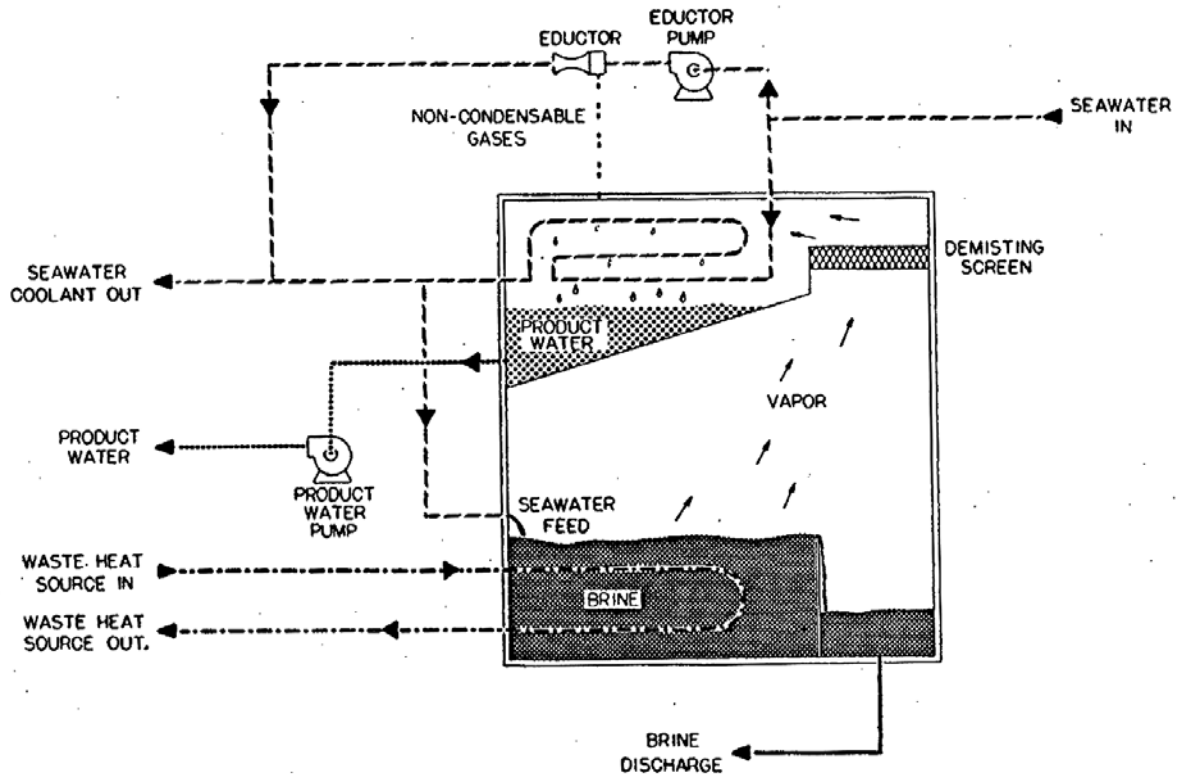

Figure 4-4

Waste heat recovery evaporation process

4.5 THERMAL DISCHARGE. A problem resulting from all distillation/condensation facilities is thermal discharge of liquids. Older high temperature facilities produce brine at very high temperatures. Cooling towers, heat exchangers, or similar equipment must be designed into the process to handle the thermal discharge from distillation/condensation facilities. More sophisticated desalination units employ a system of heat exchange devices that use the raw feed water to cool the brine and reclaim this waste heat to help provide thermal energy for system operation.

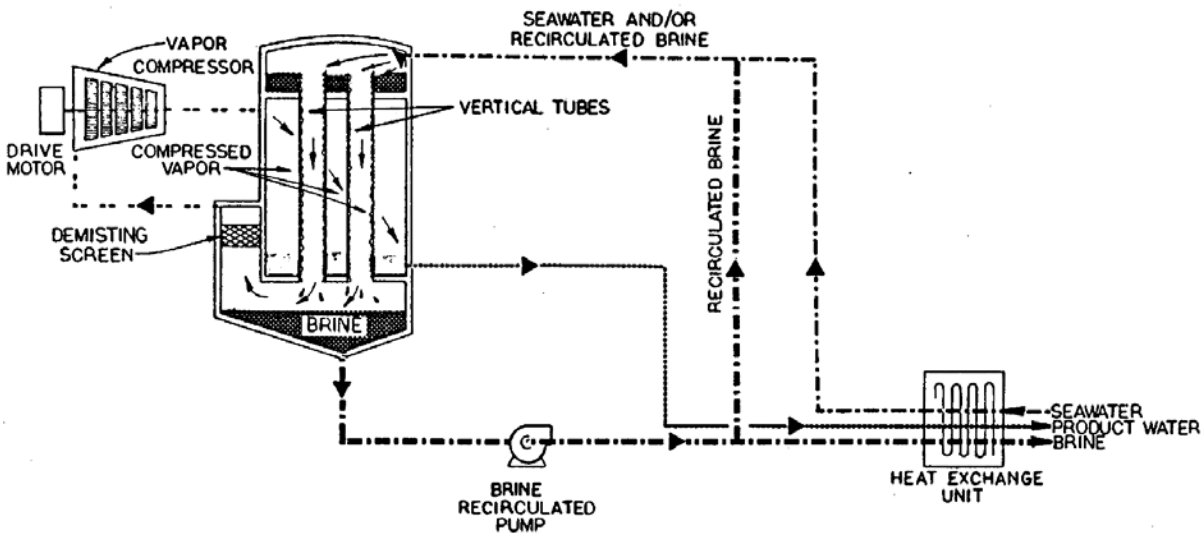

Figure 4-5

Vapor-compression vertical-tube distillation system.

4.6 DESIGN ANALYSIS. When it is necessary to review several water distillation/condensation designs, standard dimensionless analysis will be used for design comparison. If dimensionless correlations for particular aspects of design do not exist, a bench- or pilot-scale study should be done.

4.7 MATERIALS OF CONSTRUCTION. The corrosive nature of high-temperature brines, acid pretreatments, and chemical scaling can cause plant failure. Presently, the only acceptable construction materials for wetted surfaces in high-temperature systems are an austenitic stainless steel, such as AISI Type 316L or titanium. Anodized aluminum and many thermoplastic materials are acceptable for use in low-temperature systems.

4.8 DISTILLATION/CONDENSATION SYSTEM DESIGN. Pursuant to finalized site and process selection, one distillation/condensation system will usually be chosen.

When the process selection does not yield a single process, then designs must be prepared for more than one process.

4.8.1 IDENTIFICATION OF WORK. When the site has been selected and a schedule for construction has been prepared, this information will be made available to the water treatment engineer. The identification of the location and the time schedule will be considered in the design; this includes the date the system must be online. The minimum number and minimum size of the modules will be determined. Any restrictions that storage will place on maximum allowable downtime will also be determined. With distillation/ condensation systems, the design must address the maximum allowable total dissolved solids and, where applicable, the minimum allowable rejection of distillable material. Distillable material is defined as non-aqueous, volatile water contaminants.

4.8.2 EXISTING OR PLANNED FACILITIES. Distillation/ condensation systems design must include availability of energy information. Alternative steam sources considered in the design must include steam temperature, steam pressure, and available quantity of steam. The design must show available electrical power including voltage, amperage, phase of the available electricity, and frequency of the available electrical power.

4.8.3 RAW WATER INFORMATION. One of two circumstances will limit the quantity of raw water consumed. Both of these limitations must be considered in the design:

- The availability of raw water may place a limitation on the raw water used in the process.
- The maximum amount of waste brine that can be economically disposed of may limit the raw water used in the process.

The principle requirement in a desalination design is an accurate projection of the chemical makeup of the worst quality water that will be used as raw feed water at the site being investigated. The design must include consideration of the maximum total

dissolved solids, individual ions, maximum amount of total suspended solids present in the feed water, maximum organic contaminant loading, and any gas or potential corrosive agent that may be in the feed water. All known or anticipated future qualities of the feed water shall be considered in the design.

4.8.4 PROCESS DESIGN. When a distillation/condensation process has been identified as the most economical, then the design will be limited to the single process. The process design for any distillation/condensation process will include a minimum required input temperature and some maximum required heat sink temperature. Between these two temperature criteria, the process must be capable of producing the required product water quality and quantity. When a particular metallurgy is required for strategic, corrosion design, or economic reasons, this metallurgy shall be designated for all applicable parts, as well as spare parts. All required instrumentation must be included in the design. The design must show the required output water quality based on the worst raw water input chemistry and quality. The system design must be based on equipment with a history of successful water treatment system experience. The required experience history should include a minimum of 2 years of operating experience meeting water quality and system design goals, treatment capacity, maximum allowable repair frequency and duration, and a maximum allowable ratio of experienced capital cost to repair cost. The requirement for successful experience will limit the amount of untested innovation used at a facility.