



PDHonline Course C624 (2 PDH)

**An Introduction to Utilidors, Power
Distribution and Communication
Systems in Cold Regions**

Instructor: J. Paul Guyer, P.E., R.A., Fellow ASCE, Fellow AEI

2020

PDH Online | PDH Center

5272 Meadow Estates Drive
Fairfax, VA 22030-6658
Phone: 703-988-0088
www.PDHonline.com

An Approved Continuing Education Provider

An Introduction to Utilidors, Power Distribution and Communication Systems in Cold Regions

J. Paul Guyer, P.E., R.A., Fellow ASCE, Fellow AEI

CONTENTS

1. UTILIDORS

2. ELECTRIC POWER DISTRIBUTION AND COMMUNICATION SYSTEMS

(This publication is adapted from the *Unified Facilities Criteria* of the United States Government which is in the public domain, authorized for unlimited distribution and not copyrighted.)

(Some of the Figures, Tables and Formulas in this publication may at times be a little difficult to read, but they are the best available. **DO NOT PURCHASE THIS PUBLICATION IF THIS LIMITATION IS UNACCEPTABLE TO YOU.**)

The Figures, Tables and Symbols in this document are in some cases a little difficult to read, but they are the best available. **DO NOT PURCHASE THIS COURSE IF THE FIGURES, TABLES AND SYMBOLS ARE NOT ACCEPTABLE TO YOU.**

1. UTILIDORS

1.1 GENERAL. A utilidor is a conduit that contains multiple utility systems such as water, sewerage, fuel oil, gas, electrical power, telephone, and central heating in various combinations or in some cases all together. They have been used at a number of installations and communities in the North American Arctic. Utilidors are very expensive and can only be justified for special situations. In most cases individually insulated pipes in a common trench or on a common pile will be more economical. Utilidors have been constructed above and below ground, and range in size from a simple insulated conduit to a walk-through passageway. Figures 1-1 and 1-2 illustrate typical utilidor configurations that have been constructed recently in the cold regions. These new designs typically incorporate lighter construction materials than the reinforced concrete used previously at many installations.

1.2 DESIGN CONSIDERATIONS. The thermal design of the utilidor and the the foundation design are influenced by the types of utilities that are included. The inclusion of power, telephone, and gas lines along with water and sewerage in a utilidor will not cause design or operational problems. However, the inclusion of central heating lines is more complex. Their heat losses are usually great enough to protect the water and sewage pipes from freezing but the utilidor usually has to be much bigger to provide continuous easy access to steam and condensate lines, and therefore construction costs will increase. Problems also occur because this heat source is constant and must operate all or most of the year. In the summer, undesirably high domestic water supply

temperatures can result due to exposure to the excess heat (<80 deg F). The heating of a large air space in the utilidor is less efficient than direct heating and circulation of the water supply in the winter. Thermal stratification can cause freezing of the lower pipes in large utilidors even when the average air temperature is adequate. Figure 1-3 illustrates the temperature variation within a small utilidor. The cold water line was placed on one side to maintain desirable temperatures for the consumers and the hot water lines on the other side. Under extreme conditions this cold water line froze and burst due to the thermal shielding, in spite of the continuous circulation of hot water. When transport methods permit prefabrication of the major utilidor components is recommended to reduce construction costs in the field. The heat sources for freeze protection should be located near the bottom of large utilidors if possible to ensure distribution of heat. Sensitive piping (e.g. water) should not then be shielded from these heat sources. If the heat sources (i.e. steam and condensate lines) are operational all year, separate insulation of domestic water lines is recommended to maintain acceptable cold water temperatures for domestic use. The utilidors shown in Figure 1-1 all have prefabricated components. All of these units can be entirely prefabricated in a convenient unit length. A hydrant unit on an above-ground utilidor of the type in figure 1-2b is shown in figure 1-4. When both water and sewage lines are exposed in the same utilidor, the sewer access cleanouts must be sealed to prevent cross connections. Flanged elbows or pipes larger than 8 inches in diameter are large enough to insert cleaning or thawing equipment. Standard fittings or smaller pipes do not provide adequate access in both directions. Figures 1-5 illustrates details of sewer cleanouts that have been used for this purpose.

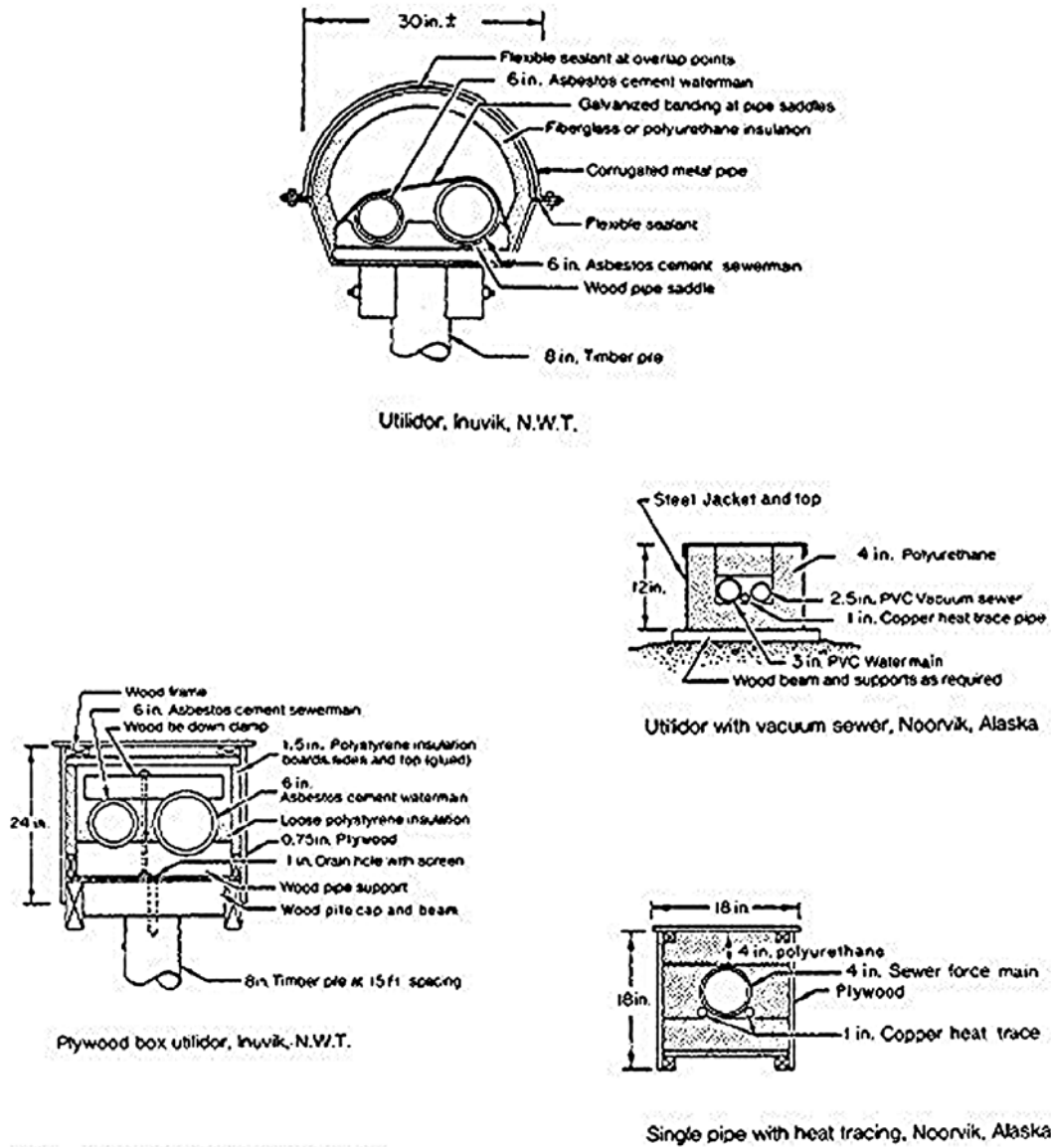

Utilidor, Inuvik, N.W.T.

Utilidor with vacuum sewer, Noorvik, Alaska

Plywood box utilidor, Inuvik, N.W.T.

Single pipe with heat tracing, Noorvik, Alaska

Figure 1-1

Various utilidors installed in cold regions

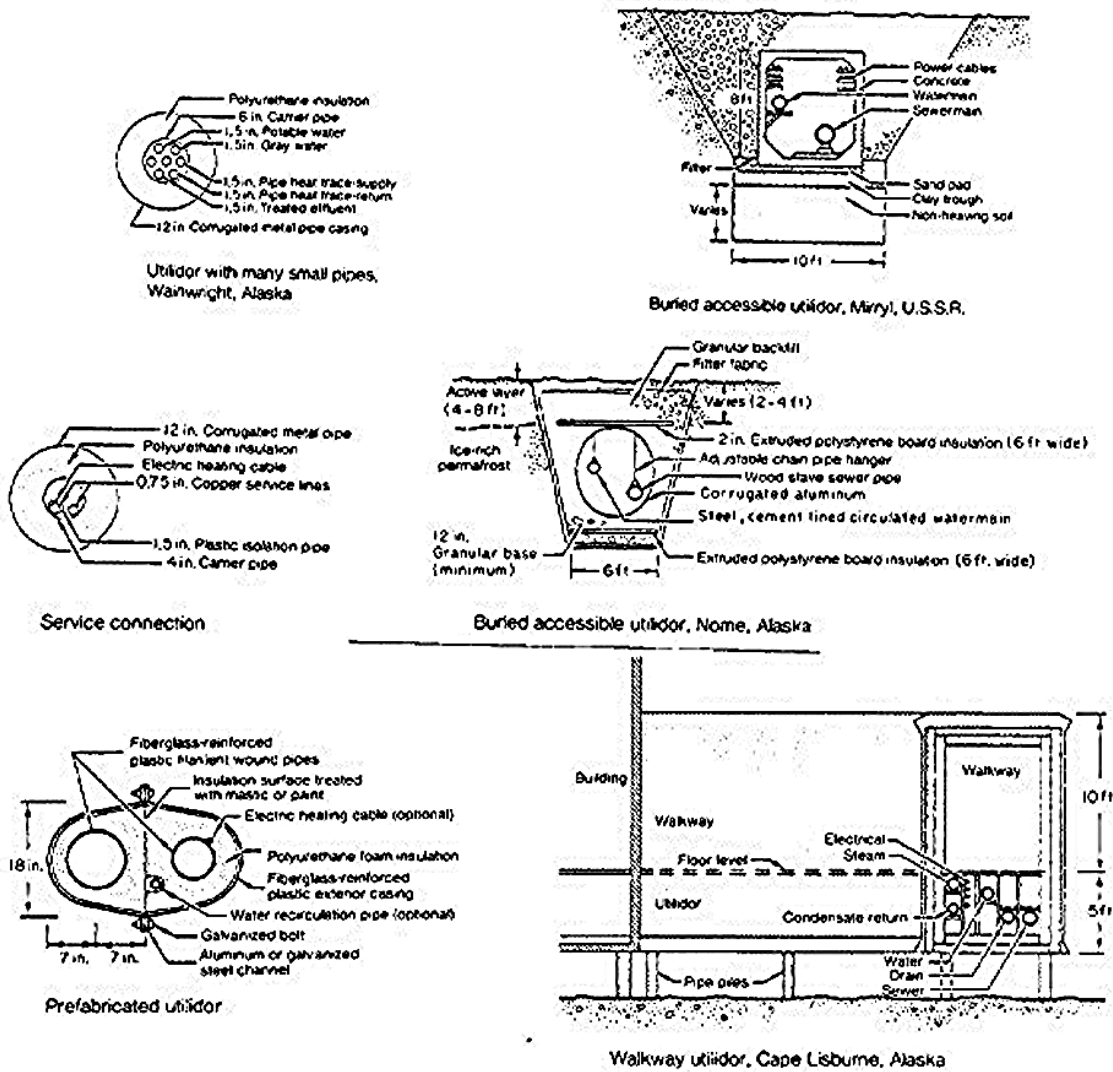

Figure 1-2
Typical utilidors

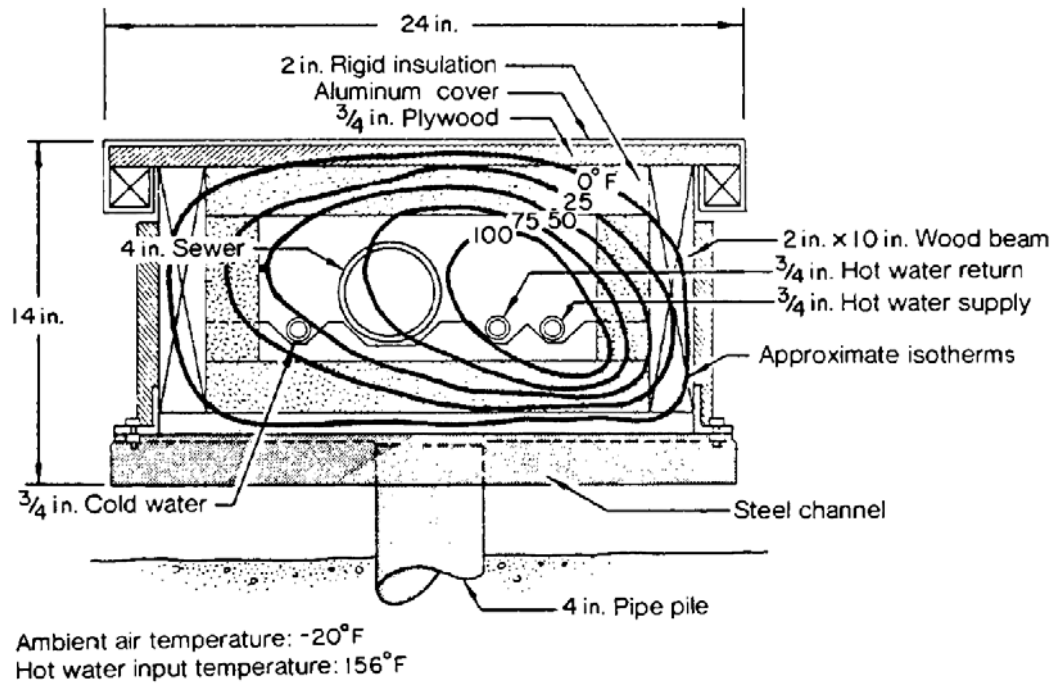

Figure 1-3

Temperature variation in a small utilidor with central hot water distribution

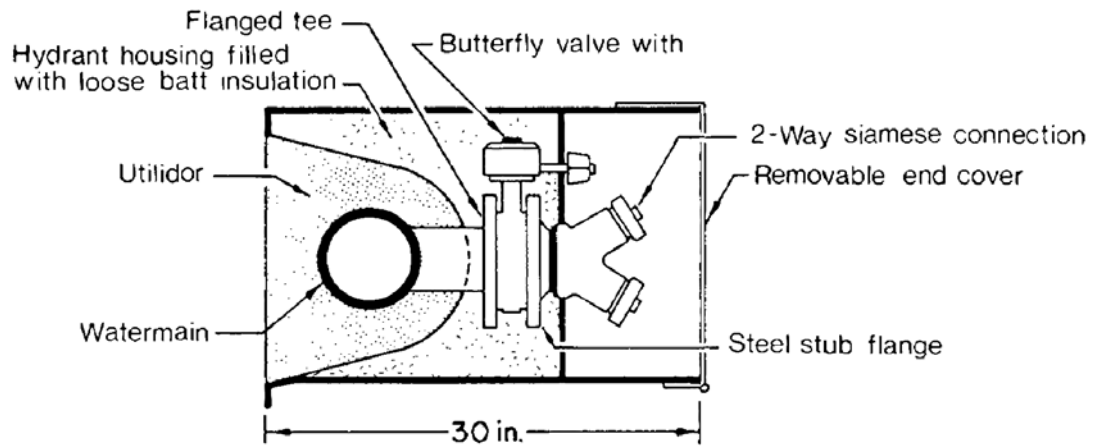

Figure 1-4

Above-ground utilidor hydrant

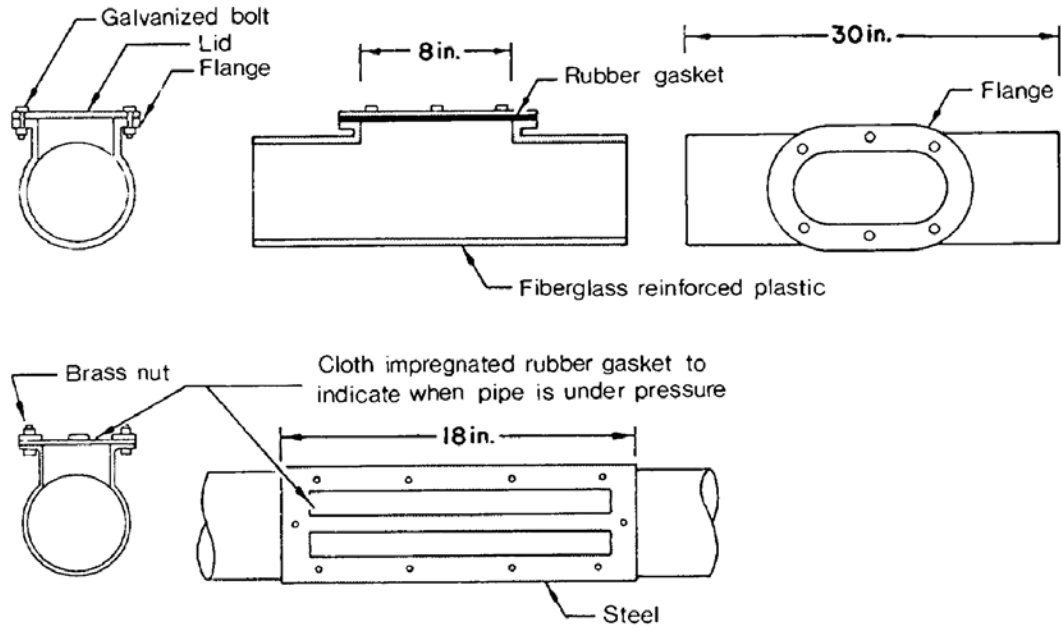

Figure 1-5
Sewer cleanouts

2. POWER DISTRIBUTION AND COMMUNICATION SYSTEMS

2.1 GENERAL. The basic design requirements for wire and cable networks for power transmission and communication systems are not unique in the cold regions and the professional literature should be used for the design of these systems. Special concern is needed to ensure proper grounding in permafrost areas, to maintain stability of towers, poles, guy wires and anchors, and for direct burial of cables.

2.2 GROUNDING. Areas with permafrost do not provide acceptable grounding conditions due to the high resistance of frozen ground. In these locations all the facilities are tied together, including electrical wiring, petroleum, oil, and lubricant (POL) piping metal building, POL storage tanks, water and sewer lines, etc., to form one large grid network. This network is then connected to a water well casing that penetrates the permafrost layer and results in an acceptable ground. If no well casing exists, the grid system is connected to a ground rod that does not penetrate the permafrost. This will provide a common floating ground with everything at the same electrical potential. This is an acceptable approach as long as everything is bonded to that common ground. Another possibility is to place a grounding cable grid into a nearby lake.

2.3 UNDERGROUND SYSTEMS. Power and communication networks have been successfully installed in utilidor systems. The direct burial of cables in the active layer in frost-susceptible soils must be avoided. The freezing and expansion of these soils will result in structural failure of the cable or severe mechanical damage. Buried conduits or

ducts must be placed in non-frost-susceptible backfill materials. Prime consideration will be given to placing a gravel and non-frost-susceptible material pad on the existing ground surface and burying the cables in this new pad if a buried system is required. As shown in figure 2-1, the gravel pad also serves as a road or walkway.

2.4 AERIAL SYSTEMS. Ice buildup will be a problem for aerial cables, particularly in coastal locations. Preventive measures have included the use of a steel conductor to increase tensile strength and to allow resistance thawing. The major engineering problem with aerial systems in the cold regions is the stability of the supporting towers or poles. The upper soil layer, known as the active zone, goes through a freezing

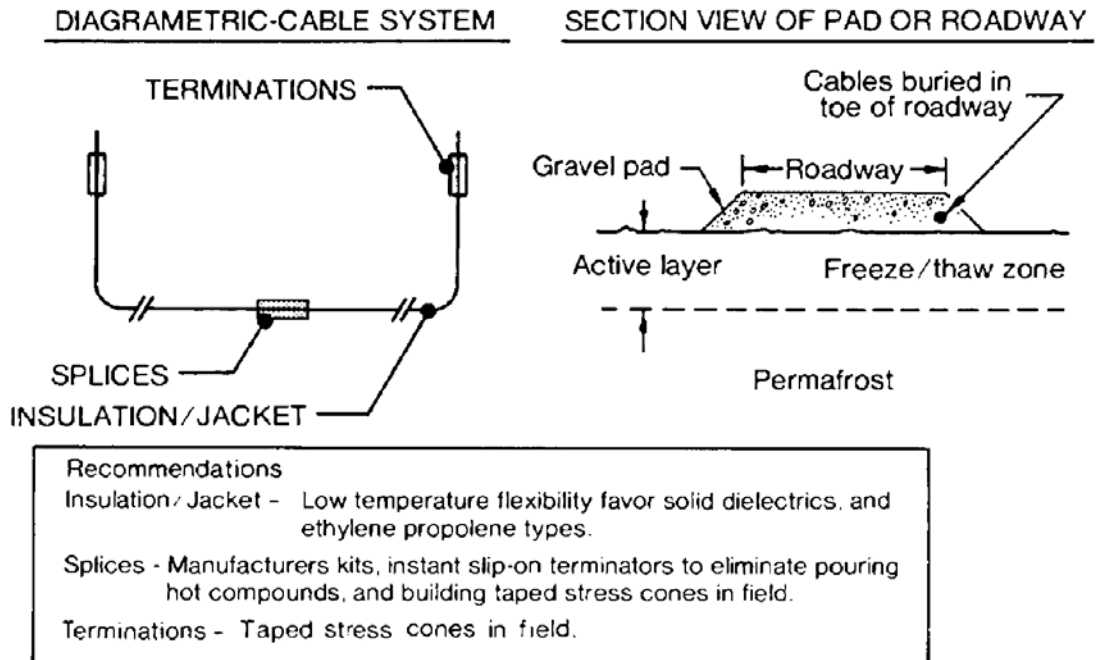

Figure 2-1

Underground cable guidelines

and thawing cycle on an annual basis. In the spring this zone may go through several freezing cycles due to warm days and cold nights. This freezing causes significant expansion, depending on the soil type and moisture content. The expansion is very significant with fine-textured silty soils when a source of unfrozen water is available. The practical effect on towers and poles is to apply an upward force to the unit that may result in overstress and mechanical failure or in differential vertical movement between components. It is necessary to design the towers or poles to resist these upward forces, or to allow the units to "float" up and down with the expansion and contraction caused by heaving of the active layer, or to replace the frost-susceptible soils with clean gravel.

In many cases the utility pole will move up due to the heaving forces but cannot return to its original position because of the flow of soil into the void. The net effect is an annual increment of upward movement that will eventually "jack" the pole out of the ground.

2.4.1 TOWERS. Typical designs for tower foundations on gravel pads and on or in frost-susceptible soils are shown in figures 2-2 and 2-3. The above-surface gravel pads provide some surcharge for resistance to heaving forces but some vertical movement is likely. At the end of the thaw period the pad will settle to its original position. The anchors for guyed towers provide the major resistance to uplift and provide lateral stability. If the footings for towers are placed in the frost-susceptible material they will be moved upward during the heaving phase, but as described in the previous section, the footing will not then settle back to its original position when seasonal thawing is complete. A progressive failure will result because the footing will be moved upward another increment each year until the resistance to overturning is insufficient.

2.4.2 POLES. A very strong bond can develop between the frozen soil and the surface of an imbedded power pole. This bond, if developed in the active layer with frost-susceptible soils, will lift the pole out of the ground. Wooden poles are commonly used for both power and communications systems. Two measures are commonly taken for permanent construction where permafrost is relatively close (3-5 feet) to the surface:

- Sufficient embedment in permafrost is provided so that the bond developed in that zone can resist the uplift forces due to heaving in the active layer.
- The active zone portion of the hole is backfilled with non-frost-susceptible materials or this portion of the pole is wrapped with a 10-mil polyethylene sleeve to prevent development of a bond.

The "rule-of-thumb" for poles in the 50-foot range is to place 10 percent of the above-ground height plus another 4 feet into the permafrost (example-50 feet above ground height would require 9 feet of embedment). A "rule-of-thumb" for shorter poles is to provide an embedment in permafrost for a depth equal to about 2-1/2 times the thickness of the active layer. Holes for these poles or support piles are made with a drill or soil auger and are made slightly larger (3-4 inches) than the diameter of the pole. A slurry of native soil or sand with water is then placed around the pole to the top of permafrost. This construction is often done in the winter when the active layer is also frozen. This will allow easier access with minimal environmental disturbance. Rock-filled cribs (fig 2-3) are used where permafrost is very deep, or rock very shallow, or for temporary or semi-permanent construction. Tripod or "tepee" pole configurations using local tree saplings or poles in gravel-filled drums have been used for lightweight wires and cables in expedient situations.

2.4.3 ANCHORS. Anchors for tower guy wires will be designed in accordance with the professional literature. The major concern is progressive movement or "creep" of the

anchor in ice-rich soils with temperatures just below the freezing point. Manufacturers' ratings for design capacities of commercially available earth anchors will be reduced by 75% if placed in thawed soil above the permafrost layer. Special helical anchors have been developed for installation in permafrost.

2.5 SPECIAL CONSIDERATIONS. There are other special considerations that relate to construction of electrical distribution systems in the cold regions due to responses to low temperatures or other environmental factors:

2.5.1 Nylon-jacketed conductors (type THWN), when used at low ambient temperatures, tend to experience separation of the insulation from the jacket.

2.5.2 Molded case circuit breakers and stored potential switches are not always dependable at extremely low temperatures. The alternative use of fuses should be considered or supplemental heat provided to raise the ambient temperature of the equipment enclosure.

2.5.3 Low temperature, special alloy steel is frequently used for transformers, circuit breakers and other exterior electrical distribution apparatus.

2.5.4 Cold weather starting of street lighting can be a problem. Mercury vapor lights are especially difficult to start. Either the lights must remain energized continuously during extreme low temperatures or provided with integral thermostats to turn on the lights

when the temperature drops below -22 degrees F, the present low limit of the typical ballast manufacturer's ratings.

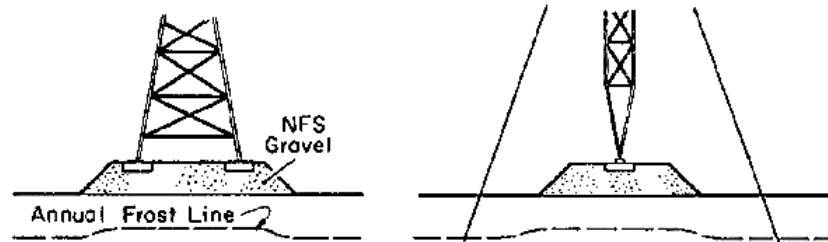

Trussed Tower Guyed Tower
a. Gravel mat with surface footings

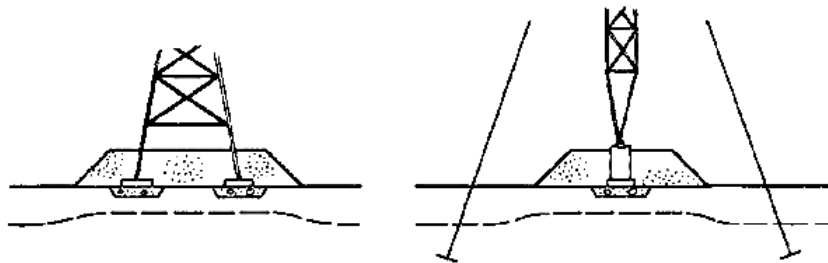

b. Gravel mat with buried footings

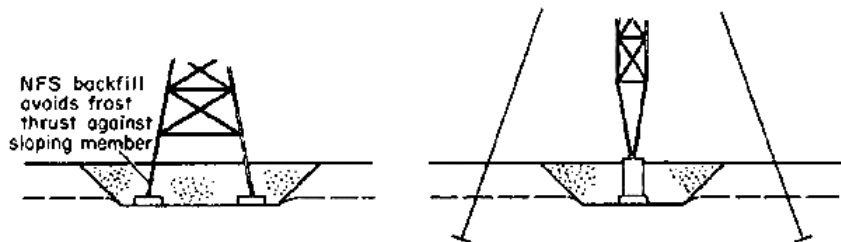

c. Gravel backfill with buried footings

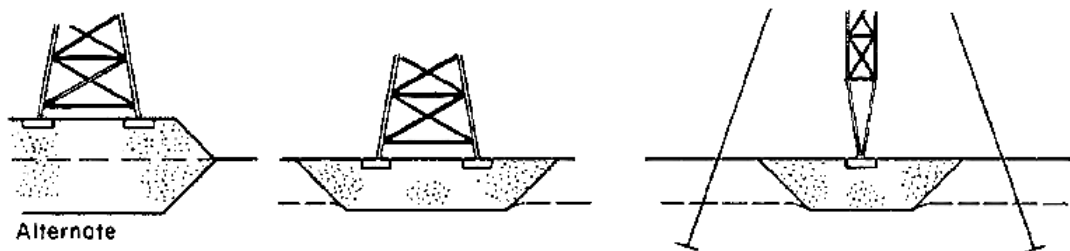

d. Gravel backfill with surface footings

Figure 2-2

Granular pad utility tower foundations (NFS = non-frost-susceptible materials)

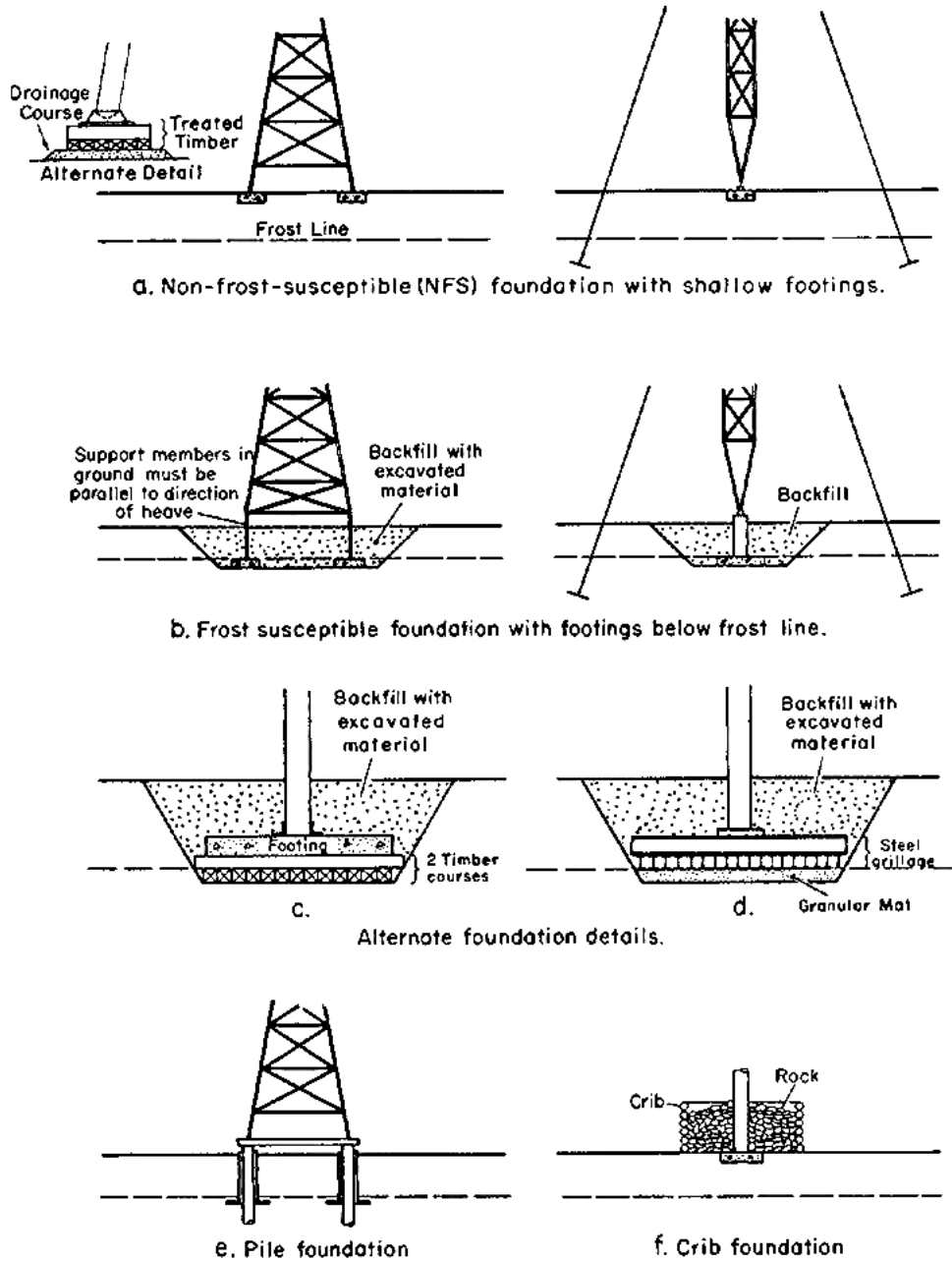

Figure 2-3
Foundations employing minimum and no granular material
for utility towers and power poles