



PDHonline Course C647 (6 PDH)

An Introduction to Seepage and Drainage

Instructor: J. Paul Guyer, P.E., R.A., Fellow ASCE, Fellow AEI

2020

PDH Online | PDH Center

5272 Meadow Estates Drive
Fairfax, VA 22030-6658
Phone: 703-988-0088
www.PDHonline.com

An Approved Continuing Education Provider

An Introduction to Seepage and Drainage

J. Paul Guyer, P.E., R.A.

CONTENTS

- 1. INTRODUCTION**
- 2. SEEPAGE ANALYSIS**
- 3. SEEPAGE CONTROL BY CUTOFF**
- 4. DESIGN OF DRAINAGE BLANKET AND FILTERS**
- 5. WELLPOINT SYSTEMS AND DEEP WELLS**
- 6. LININGS FOR RESERVOIRS AND POLLUTION CONTROL FACILITIES**
- 7. EROSION CONTROL**
- 8. REFERENCES**

(This publication is adapted from the *Unified Facilities Criteria* of the United States government which are in the public domain, have been authorized for unlimited distribution, and are not copyrighted.)

(The figures, tables and formulas in this publication may at times be a little difficult to read, but they are the best available. **DO NOT PURCHASE THIS PUBLICATION IF THIS LIMITATION IS NOT ACCEPTABLE TO YOU.**)

1. INTRODUCTION. This publication covers surface erosion, and analysis of flow quantity and groundwater pressures associated with underseepage. Requirements are given for methods of drainage and pressure relief. Control of soil erosion must be considered in all new construction projects. Seepage pressures are of primary importance in stability analysis and in foundation design and construction. Frequently, drawdown of groundwater is necessary for construction. In other situations, pressure relief must be incorporated in temporary and permanent structures. For erosion analysis, the surface water flow characteristics, soil type, and slope are needed. For analysis of major seepage problems, determine permeability and piezometric levels by field observations.

2. SEEPAGE ANALYSIS

2.1 FLOW NET. Figure 1 shows an example of flow net construction. Use this procedure to estimate seepage quantity and distribution of pore water pressures in two-dimensional flow. Flow nets are applicable for the study of cutoff walls and wellpoints, or shallow drainage installations placed in a rectangular layout whose length in plan is several times its width. Flow nets can also be used to evaluate concentration of flow lines.

2.1.1 GROUNDWATER PRESSURES. For steady state flow, water pressures depend on the ratio of mean permeability of separate strata and the anisotropy of layers. A carefully drawn flow net is necessary to determine piezometric levels within the flow field or position of the drawdown curve.

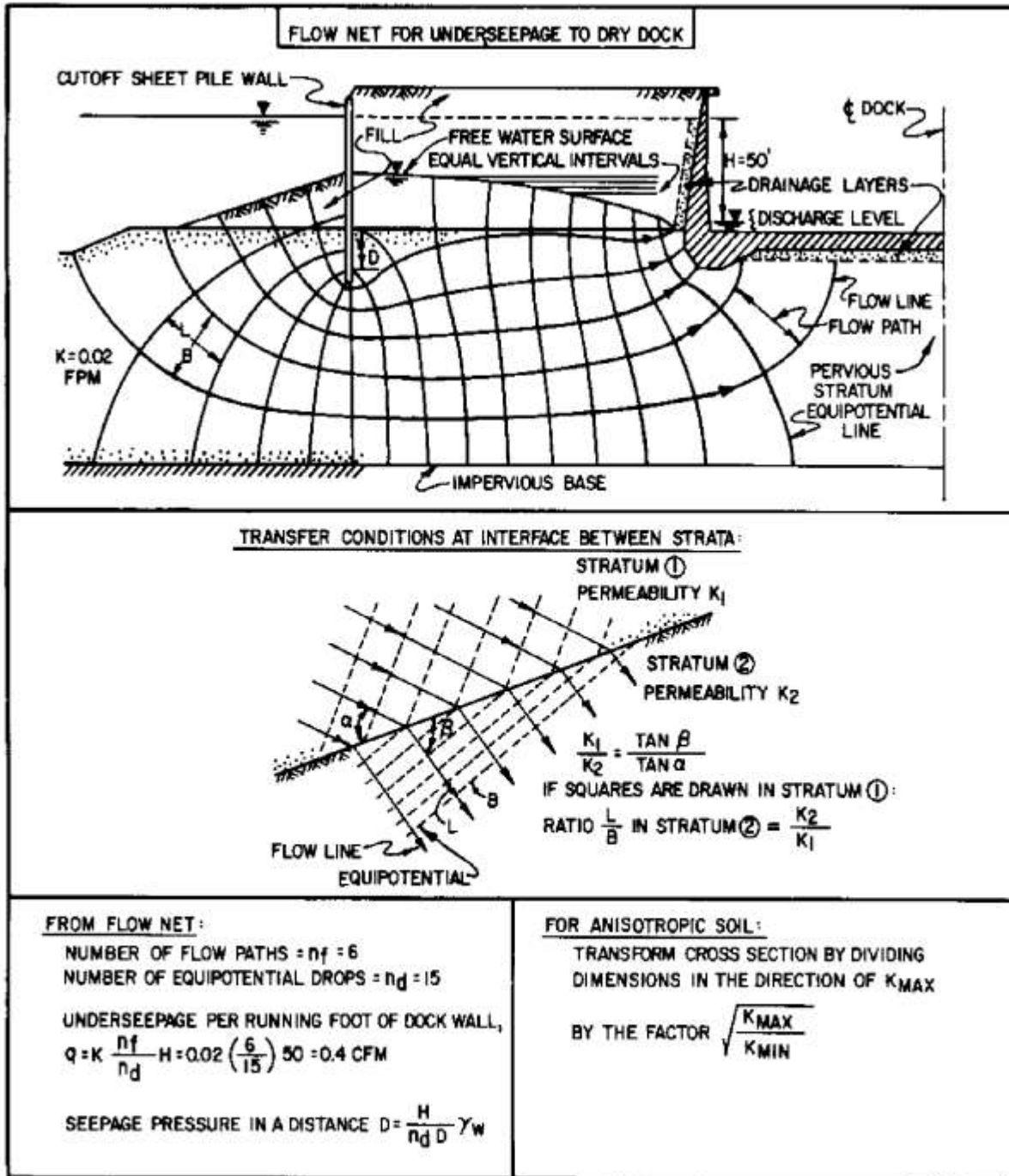

FIGURE 1
Flow Net Construction and Seepage Analysis

Figure 1
Flow Net Construction and Seepage Analysis

RULES FOR FLOW NET CONSTRUCTION

1. WHEN MATERIALS ARE ISOTROPIC WITH RESPECT TO PERMEABILITY, THE PATTERN OF FLOW LINES AND EQUIPOTENTIALS INTERSECT AT RIGHT ANGLES. DRAW A PATTERN IN WHICH SQUARE FIGURES ARE FORMED BETWEEN FLOW LINES AND EQUIPOTENTIALS.
2. USUALLY IT IS EXPEDIENT TO START WITH AN INTEGER NUMBER OF EQUIPOTENTIAL DROPS, DIVIDING TOTAL HEAD BY A WHOLE NUMBER, AND DRAWING FLOW LINES TO CONFORM TO THESE EQUIPOTENTIALS. IN THE GENERAL CASE, THE OUTER FLOW PATH WILL FORM RECTANGULAR RATHER THEN SQUARE FIGURES. THE SHAPE OF THESE RECTANGLES (RATIO B/L) MUST BE CONSTANT.
3. THE UPPER BOUNDARY OF A FLOW NET THAT IS AT ATMOSPHERIC PRESSURE IS A "FREE WATER SURFACE". INTEGER EQUIPOTENTIALS INTERSECT THE FREE WATER SURFACE AT POINTS SPACED AT EQUAL VERTICAL INTERVALS.
4. A DISCHARGE FACE THROUGH WHICH SEEPAGE PASSES IS AN EQUIPOTENTIAL LINE IF THE DISCHARGE IS SUBMERGED, OR A FREE WATER SURFACE IF THE DISCHARGE IS NOT SUBMERGED. IF IT IS A FREE WATER SURFACE, THE FLOW NET FIGURES ADJOINING THE DISCHARGE FACE WILL NOT BE SQUARES.
5. IN A STRATIFIED SOIL PROFILE WHERE RATIO OF PERMEABILITY OF LAYERS EXCEEDS 10, THE FLOW IN THE MORE PERMEABLE LAYER CONTROLS. THAT IS, THE FLOW NET MAY BE DRAWN FOR MORE PERMEABLE LAYER ASSUMING THE LESS PERMEABLE LAYER TO BE IMPERVIOUS. THE HEAD ON THE INTERFACE THUS OBTAINED IS IMPOSED ON THE LESS PERVIOUS LAYER FOR CONSTRUCTION OF THE FLOW NET WITHIN IT.
6. IN A STRATIFIED SOIL PROFILE WHERE RATIO OF PERMEABILITY OF LAYERS IS LESS THAN 10, FLOW IS DEFLECTED AT THE INTERFACE IN ACCORDANCE WITH THE DIAGRAM SHOWN ABOVE.
7. WHEN MATERIALS ARE ANISOTROPIC WITH RESPECT TO PERMEABILITY, THE CROSS SECTION MAY BE TRANSFORMED BY CHANGING SCALE AS SHOWN ABOVE AND FLOW NET DRAWN AS FOR ISOTROPIC MATERIALS. IN COMPUTING QUANTITY OF SEEPAGE, THE DIFFERENTIAL HEAD IS NOT ALTERED FOR THE TRANSFORMATION.
8. WHERE ONLY THE QUANTITY OF SEEPAGE IS TO BE DETERMINED, AN APPROXIMATE FLOW NET SUFFICES. IF PORE PRESSURES ARE TO BE DETERMINED, THE FLOW NET MUST BE ACCURATE.

FIGURE 1 (continued)
Flow Net Construction and Seepage Analysis

2.1.2 SEEPAGE QUANTITY. Total seepage computed from flow net depends primarily on differential head and mean permeability of the most pervious layer. The ratio of permeabilities of separate strata or their anisotropy has less influence. The ratio n_f/n_d in Figure 1 usually ranges from $\frac{1}{2}$ to $\frac{2}{3}$ and thus for estimating seepage quantity a roughly drawn flow net provides a reasonably accurate estimate of total flow. Uncertainties in the permeability values are much greater limitations on accuracy. For special cases, the flow regime can be analyzed by the finite element method. Mathematical expressions for the flow are written for each of the elements, considering boundary conditions. The resulting system of equations is solved by computer to obtain the flow pattern..

2.2 SEEPAGE FORCES. The flow of water through soil exerts a force on the soil called a seepage force. The seepage pressure is this force per unit volume of soil and is equal to the hydraulic gradient times the unit weight of water.

$$P_s = i \gamma_w$$

where

P_s = seepage pressure

i = hydraulic gradient

γ_w = unit weight of water

The seepage pressure acts in a direction at right angles to the equipotential lines (see Figure 1). The seepage pressure is of great importance in analysis of the stability of excavations and slopes because it is responsible for the phenomenon known as boiling or piping.

2.2.1 BOILING. Boiling occurs when seepage pressures in an upward direction exceed the downward force of the soil. The condition can be expressed in terms of critical hydraulic gradient. A minimum factor of safety of 2 is usually required, i.e.,

$$I_c = i_{\text{critical}} = (\gamma_T - \gamma_W) / \gamma_W = \gamma_b / \gamma_W$$

$$F_s = I_c / i = 2$$

where:

i = actual hydraulic gradient

γ_T = total unit weight of the soil

γ_W [gamma]+W, = unit weight of water

γ_b = buoyant unit weight of soil

2.2.2 PIPING AND SUBSURFACE EROSION. Most piping failures are caused by subsurface erosion in or beneath dams. These failures can occur several months or even years after a dam is placed into operation. In essence, water that comes out of the ground at the toe starts a process of erosion (if the exit gradient is high enough) that culminates in the formation of a tunnel-shaped passage (or "pipe") beneath the structure. When the passage finally works backward to meet the free water, a mixture of soil and water rushes through the passage, undermining the structure and flooding the channel below the dam. It has been shown that the danger of a piping failure due to subsurface erosion increases with decreasing grain size. Similar subsurface erosion problems can occur in relieved drydocks, where water is seeping from a free source to a drainage or filter blanket beneath the floor or behind the walls. If the filter fails or is defective and the hydraulic gradients are critical, serious concentrations of flow can result in large voids and eroded channels. Potential passageways for the initiation of piping include: uniformly graded gravel deposits, conglomerate, open joints in bedrock, cracks caused by earthquakes or crustal movements, open joints in pipelines, hydraulic fracture, open voids in coarse boulder drains including French

drains, abandoned wellpoint holes, gopher holes, cavities formed in levee foundations by rotting roots or buried wood, improper backfilling of pipelines, pipes without antiseepage collars, etc. Failure by piping requires progressive movement of soil particles to a free exit surface. It can be controlled by adequately designed filters or relief blankets. Guidelines for preventing piping beneath dams may be found in Reference 1, *Security from Under Seepage of Masonry Dams on Earth Foundations*, by Lee.

3. SEEPAGE CONTROL BY CUTOFF.

3.1 METHODS. Procedures for seepage control include cutoff walls for decreasing the seepage quantity and reducing the exit gradients, and drainage or relief structures that increase flow quantity but reduce seepage pressures or cause drawdown in critical areas. See Table 1.

3.2 SHEETPIILING. A driven line of interlocking steel sheeting may be utilized for a cutoff as a construction expedient or as a part of the completed structure.

3.2.1 APPLICABILITY. The following considerations govern the use of sheetpiling:

TABLE I
Cutoff Methods for Seepage Control

Method	Applicability	Characteristics and Requirements
Sheet pile cut off wall	Suited especially for stratified soils with high horizontal and low vertical permeability or pervious hydraulic fill materials. May be easily damaged by boulders or buried obstructions. Tongue and groove wood sheering utilized for shallow excavation in soft to medium soils. Interlocking steel sheerpiling is utilized for deeper cutoff.	Steel sheeting must be carefully driven to maintain interlocks tight. Steel H-pile soldier beams may be used to minimize deviation of sheeting in driving. Some deviation of sheeting from plumb toward the side with least horizontal pressure should be expected. Seepage through interlocks is minimized where tensile force acts across interlocks. For straight wall sheeting an appreciable flow may pass through interlocks. Decrease interlock leakage by filling interlocks with sawdust, bentonite, cement grout, or similar material.
Compacted barrier of impervious soil	Formed by compacted backfill in a cutoff trench carried down to impervious material or as a core section in earth dams.	Layers or streaks of pervious material in the impervious zone must be avoided by careful selection and mixing of borrow materials, scarifying lifts, aided by sheepsfoot rolling. A drainage zone downstream of an impervious section of the embankment is necessary in most instances.

Table 1
Cutoff Methods for Seepage Control

TABLE 1 (continued)
Cutoff Methods for Seepage Control

Method	Applicability	Characteristics and Requirements
Grouted or injected cutoff	Applicable where depth or character of foundation materials make sheetpile wall or cutoff trench impractical. Utilized extensively in major hydraulic structures. May be used as a supplement below cutoff sheeting or trenches.	A complete positive grouted cutoff is often difficult and costly to attain, requiring a pattern of holes staggered in rows with carefully planned injection sequence and pressure control. See DM-7.3, Chapter 2 for materials and methods.
Slurry trench method	Suited for construction of impervious cutoff trench below groundwater or for stabilizing trench excavation. Applicable whenever cutoff walls in earth are required. Is replacing sheetpile cutoff walls.	Vertical sided trench is excavated below groundwater as slurry with specific gravity generally between 1.2 and 1.8 is pumped back into the trench. Slurry may be formed by mixture of powdered bentonite with fine-grained material removed from the excavation. For a permanent cutoff trench, such as a foundation wall or other diaphragm wall, concrete is tremied to bottom of trench, displacing slurry upward. Alternatively, well graded backfill material is dropped through the slurry in the trench to form a dense mixture that is essentially an incompressible mixture; in working with coarser gravels (which may settle out), to obtain a more reliable key into rock, and a narrower trench, use a cement-bentonite mix.

Table 1 (continued)
Cutoff Methods for Seepage Control

TABLE 1 (continued)
Cutoff Methods for Seepage Control

Method	Applicability	Characteristics and Requirements
<p>Impervious wall of mixed in-place piles.</p>	<p>Method may be suitable to form cofferdam wall where sheet pile cofferdam is expensive or cannot be driven to suitable depths, or has insufficient rigidity, or requires excessive bracing.</p>	<p>For a cofferdam surrounding an excavation, a line of overlapping mixed in-place piles are formed by a hollow shaft auger or mixing head rotated into the soil while cement grout is pumped through the shaft. Where piles cannot be advanced because of obstructions or boulders, supplementary grouting or injection may be necessary.</p>
<p>Freezing - ammonium brine or liquid nitrogen</p>	<p>All types of saturated soils and rock. Forms ice in voids to stop water. Ammonium brine is better for large applications of long duration. Liquid nitrogen is better for small applications of short duration where quick freezing is needed.</p>	<p>Gives temporary mechanical strength to soil. Installation costs are high and refrigeration plant is expensive. Some ground heave occurs.</p>

See also DM-7.2 Chapter 1, Table 10, DM-7.3 Chapter 3 (for diaphragm walls as a cutoff), and DM-7.3 Chapter 2 (for grouted cutoffs and freezing).

Table 1 (continued)
Cutoff Methods for Seepage Control

3.2.1.1 SHEETING is particularly suitable in coarse-grained material with maximum sizes less than about 6 inches or in stratified subsoils with alternating fine grained and pervious layers where horizontal permeability greatly exceeds vertical.

3.2.1.2 TO BE EFFECTIVE, sheeting must be carefully driven with interlocks intact. Boulders or buried obstructions are almost certain to damage sheeting and break interlock connections. Watertightness cannot be assumed if obstructions are present.

3.2.1.3 LOSS OF HEAD across a straight wall of intact sheeting depends on its watertightness relative to the permeability of the surrounding soil. In homogeneous fine-grained soil, head loss created by sheeting may be insignificant. In pervious sand and gravel, head loss may be substantial depending on the extent to which the flow path is lengthened by sheeting. In this case, the quantity of water passing through intact interlocks may be as much as 0.1 gpm per foot of wall length for each 10 feet differential in head across sheeting, unless special measures are taken to seal interlocks.

3.2.2 PENETRATION REQUIRED. This paragraph and Paragraph "3.2.3" below apply equally to all impervious walls listed in Table 1. Seepage beneath sheeting driven for partial cutoff may produce piping in dense sands or heave in loose sands. Heave occurs if the uplift force at the sheeting toe exceeds the submerged weight of the overlying soil column. To prevent piping or heave of an excavation carried below groundwater, sheeting must penetrate a sufficient depth below subgrade or supplementary drainage will be required at subgrade. See Figure 2 (Reference 2, Model Experiments to Study the Influence of Seepage on the Stability of a Sheeted Excavation in Sand, by Marsland) for sheeting penetration required for various safety factors against heave or piping in isotropic sands. For homogeneous but anisotropic sands, reduce the horizontal cross-section dimensions by the transformation factor of Figure 1 to obtain the equivalent cross section for isotropic conditions. See Figure 3 (Reference 2) for sheeting penetration required in layered subsoils. For clean sand,

exit gradients between 0.5 and 0.75 will cause unstable conditions for men and equipment operating on the subgrade. To avoid this, provide sheeting penetration for a safety factor of 1.5 to 2 against piping or heave.

3.2.3 SUPPLEMENTARY MEASURES. If it is uneconomical or impractical to provide required sheeting penetration, the seepage exit gradients may be reduced as follows:

3.2.3.1 FOR HOMOGENEOUS MATERIALS or soils whose permeability decreases with depth, place wellpoints, pumping wells, or sumps within the excavation.

Wellpoints and pumping wells outside the excavation are as effective in some cases and do not interfere with bracing or excavation.

3.2.3.2 FOR MATERIALS WHOSE PERMEABILITY INCREASES WITH DEPTH, ordinary relief wells with collector pipes at subgrade may suffice.

3.2.3.3 A PERVIOUS BERM placed against the sheeting, or a filter blanket at subgrade, will provide weight to balance uplift pressures. Material placed directly on the subgrade should meet filter criteria. Sheeting is particularly suitable in coarse-grained material with maximum sizes less than about 6 inches or in stratified subsoils with alternating fine grained and pervious layers where horizontal permeability greatly exceeds vertical.

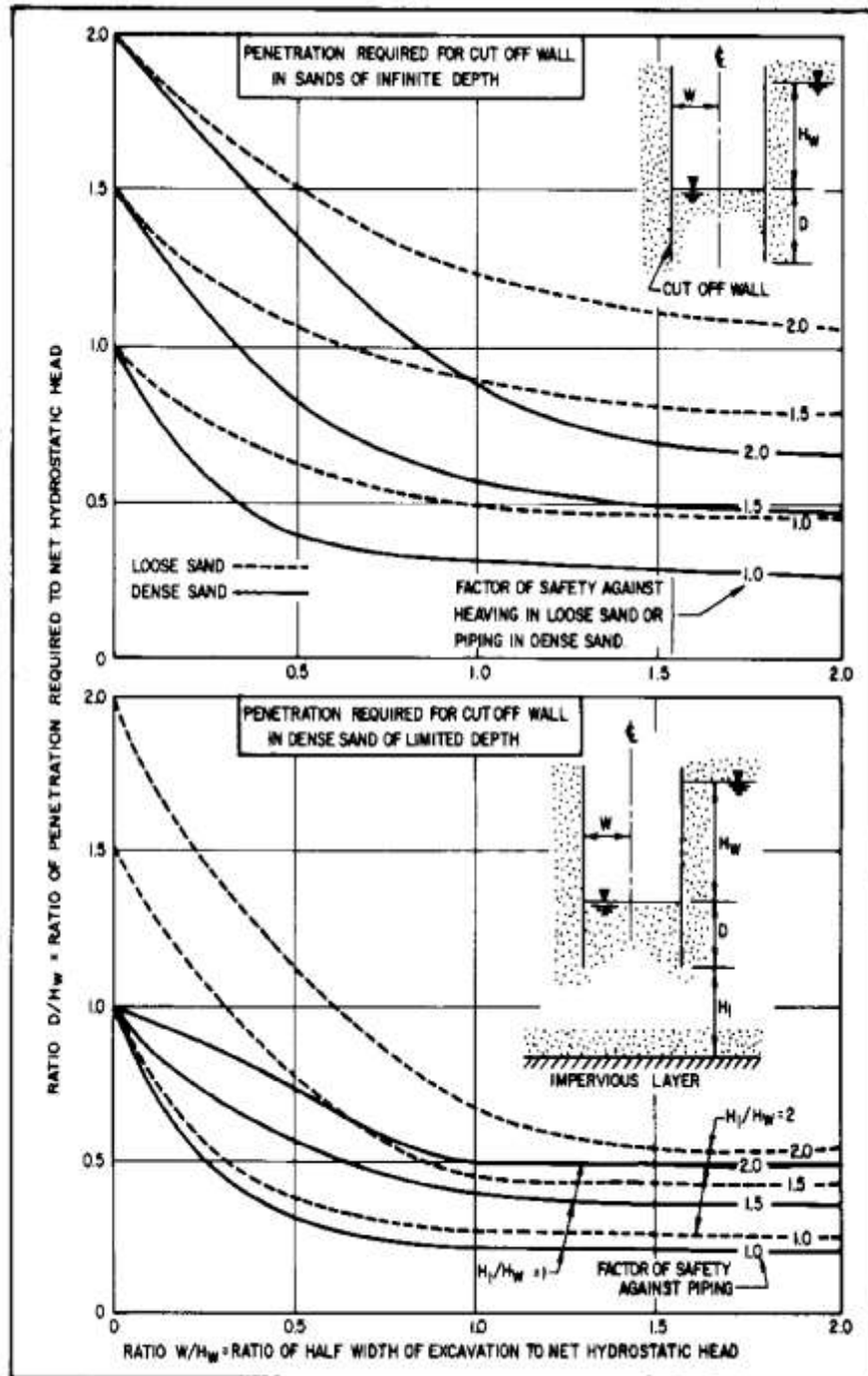

FIGURE 2
Penetration of Cut Off Wall to Prevent Piping in Isotropic Sand

Figure 2
Penetration of Cut Off Wall to Prevent Piping in Isotropic Sand

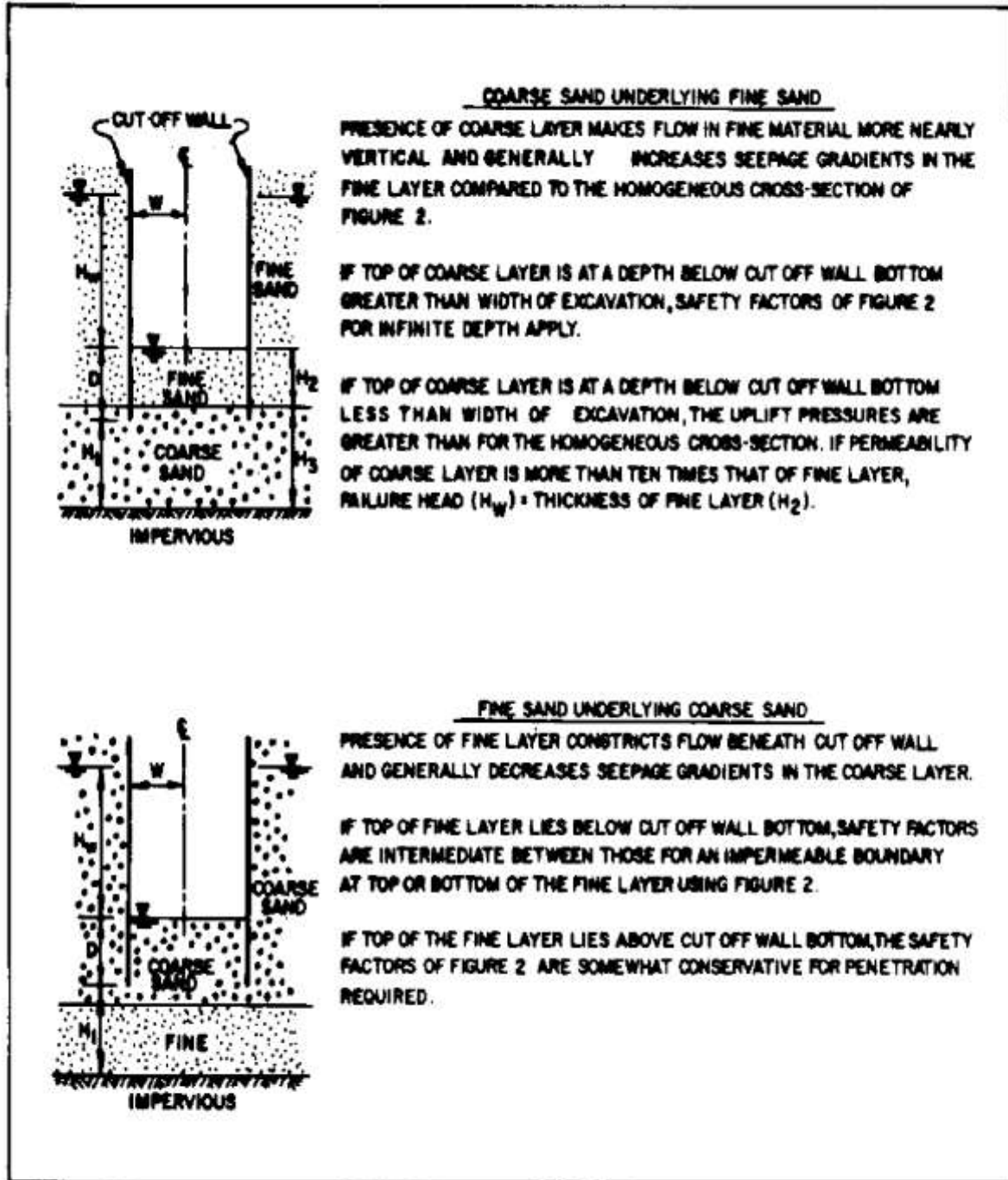

FIGURE 3
Penetration of Cut Off Wall Required to Prevent Piping in Stratified Sand

Figure 3
Penetration of Cut Off Wall Required to Prevent Piping in Stratified Sand

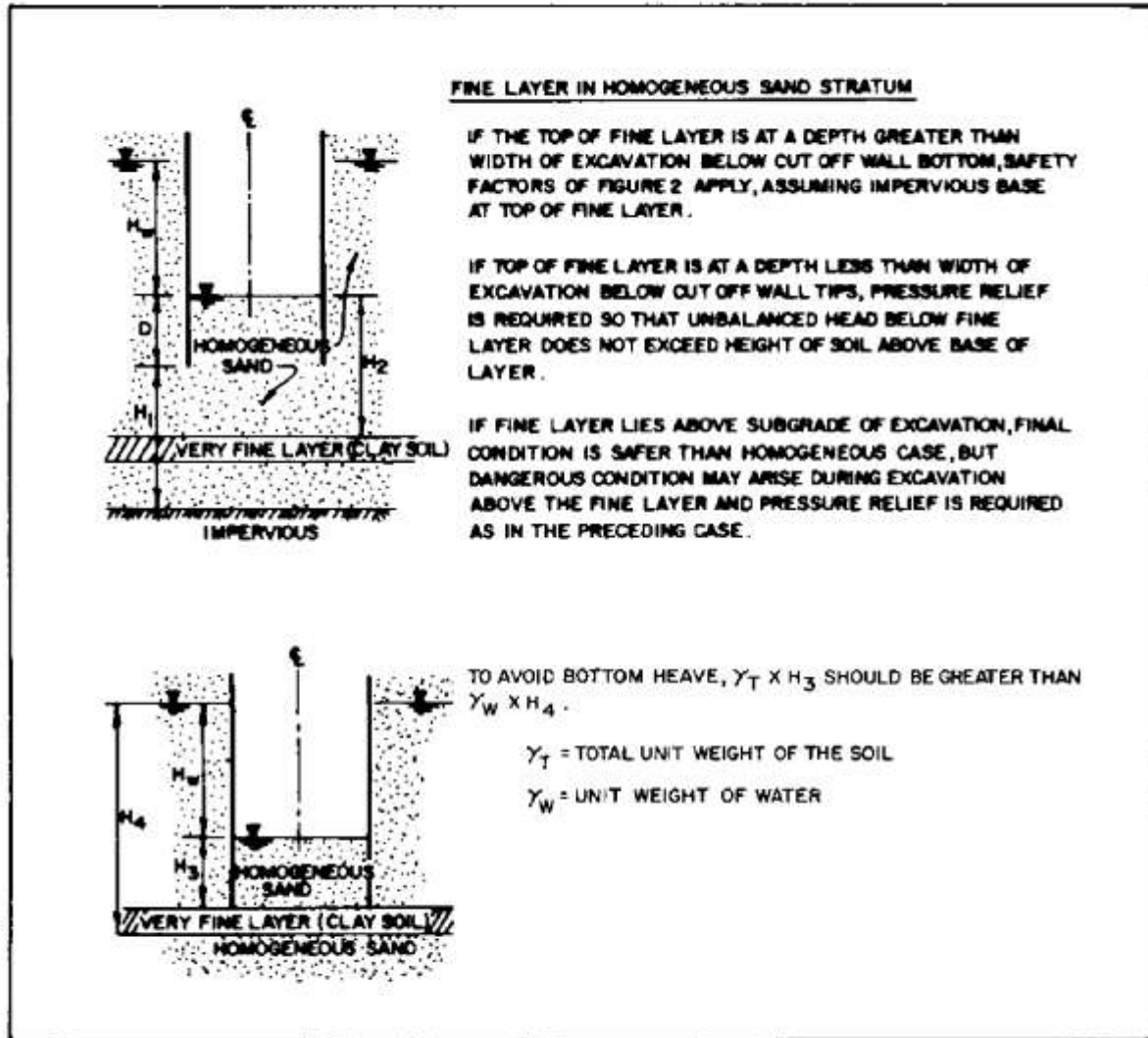

FIGURE 3 (continued)
 Penetration of Cut Off Wall Required to Prevent Piping in Stratified Sand

Figure 3 (continued)
 Penetration of Cut Off Wall Required to Prevent Piping in Stratified Sand

3.2.4 AN OUTSIDE OPEN WATER SOURCE may be blanketed with fines or bentonite dumped through water or placed as a slurry. See Table 2. Evaluate the effectiveness of these measures by flow net analysis.

3.3 GROUTED CUTOFF. Complete grouted cutoff is frequently difficult and costly to attain. Success of grouting requires careful evaluation of pervious strata for selection of appropriate grout mix and procedures. These techniques, in combination with other cutoff or drainage methods, are particularly useful as a construction expedient to control local seepage.

3.4 IMPERVIOUS SOIL BARRIERS. Backfilling of cutoff trenches with selected impervious material and placing impervious fills for embankment cores are routine procedures for earth dams.

3.4.1 COMPACTED IMPERVIOUS FILL. Properly constructed, these sections permit negligible seepage compared to the flow through foundations or abutments. Pervious layers or lenses in the compacted cutoff must be avoided by blending of borrow materials and scarifying to bond successive lifts.

3.4.2 MIXED-IN-PLACE PILES. Overlapping mixed-in-place piles of cement and natural soil forms a cofferdam with some shear resistance around an excavation.

3.4.3 SLURRY-FILLED TRENCH. Concurrent excavation of a straight sided trench and backfilling with a slurry of bentonite with natural soil is done. Alternatively, a cement bentonite mix can be used in a narrower trench where coarser gravel occurs. In certain cases, tremie concrete may be placed, working upward from the base of a slurry-filled trench, to form a permanent peripheral wall.

4. DESIGN OF DRAINAGE BLANKET AND FILTERS

4.1 FILTERS. If water flows from a silt to a gravel, the silt will wash into the interstices of the gravel. This could lead to the following, which must be avoided:

4.1.1. THE LOSS OF SILT may continue, causing creation of a cavity.

4.1.2 THE SILT MAY CLOG THE GRAVEL, stopping flow, and causing hydrostatic pressure buildup. The purpose of filters is to allow water to pass freely across the interface (filter must be coarse enough to avoid head loss) but still be sufficiently fine to prevent the migration of fines. The filter particles must be durable, e.g., certain crushed limestones may dissolve. Filter requirements apply to all permanent subdrainage structures in contact with soil, including wells. See Figure 4 for protective filter design criteria.

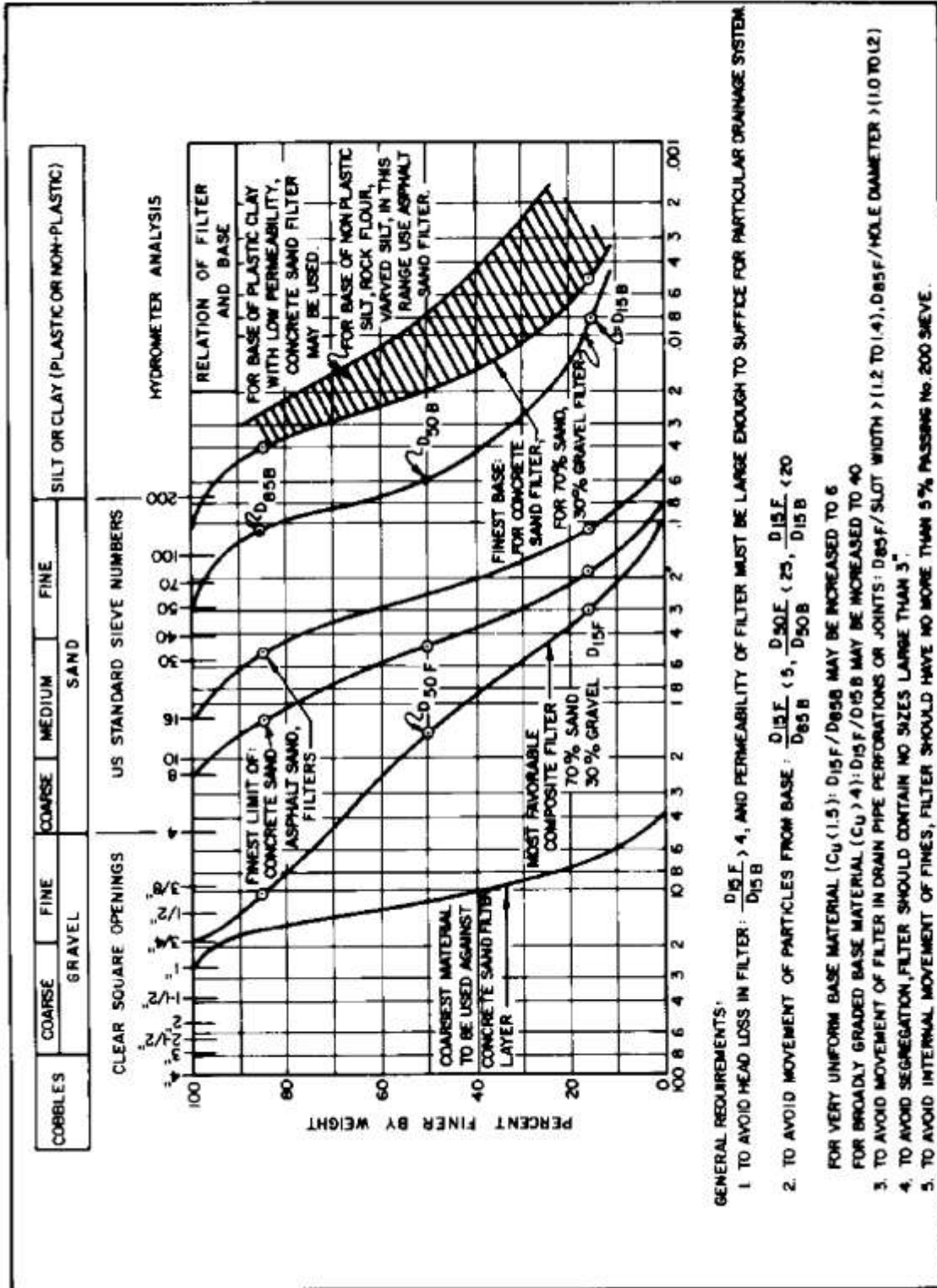

FIGURE 4 (continued)
Design Criteria for Protective Filters

Figure 4 (continued)

Design Criteria for Protective Filters

The filter may be too fine grained to convey enough water, to provide a good working surface, or to pass the water freely without loss of fines to a subdrain pipe. For this condition, a second filter layer is placed on the first filter layer; the first filter layer is then considered the soil to be protected, and the second filter layer is designed. The finest filter soil is often at the base, with coarser layers above. This is referred to as reversed or inverted filters. Concrete sand (ASTM C33, Specifications for Concrete Aggregates) suffices as a filter against the majority of fine-grained soils or silty or clayey sands. For non-plastic silt, varved silt, or clay with sand or silt lenses, use asphalt sand (ASTM D1073, Specifications for Fine Aggregates for Bituminous Paving Mixtures) but always check the criteria in Figure 4. Locally available natural materials are usually more economical than processed materials, and should be used where they meet filter criteria. The fine filter layer can be replaced with plastic filter cloths under the following conditions (after Reference 3, Performance of Plastic Filter Cloths as a Replacement for Granular Materials, by Calhoun, et al.):

4.1.2.1 NON-WOVEN FILTER CLOTHS, or woven filter cloths with less than 4% open area should not be used where silt is present in sandy soils. A cloth with an equivalent opening size (EOS) equal to the No. 30 sieve and an open area of 36% will retain sands containing silt.

4.1.2.2 WHEN STONES ARE TO BE DROPPED DIRECTLY ON THE CLOTH, or where uplift pressure from artesian water may be encountered, the minimum tensile strengths (ASTM D1682, Tests for Breaking Load and Elongation of Textile Fabrics) in the strongest and weakest directions should be not less than 350 and 200 lbs. respectively. Elongation at failure should not exceed 35%. The minimum burst strength should be 520 psi (ASTM D751, Testing Coated Fabrics). Where the cloths are used in applications not requiring high strength or abrasion resistance, the strength requirements may be relaxed.

4.1.2.3 CLOTHS MADE OF POLYPROPYLENE, polyvinyl chloride and polyethylene fibers do not deteriorate under most conditions, but they are affected by sunlight, and

should be protected from the sun. Materials should be durable against ground pollutants and insect attack, and penetration by burrowing animals.

4.1.2.4 WHERE FILTER CLOTHS ARE USED TO WRAP COLLECTION PIPES or in similar applications, backfill should consist of clean sands or gravels graded such that the D_{85} is greater than the EOS of the cloth. When trenches are lined with filter cloth, the collection pipe should be separated from the cloth by at least six inches of granular material.

4.1.2.5 CLOTHS SHOULD BE MADE OF MONOFILAMENT YARNS, and the absorption of the cloth should not exceed 1% to reduce possibility of fibers swelling and changing EOS and percent of open area. For further guidance on types and properties of filter fabrics see Reference 4, Construction and Geotechnical Engineering Using Synthetic Fabrics, by Koerner and Welsh.

4.2 DRAINAGE BLANKET. Figure 5 shows typical filter and drainage blanket installations.

4.2.1 PERMEABILITY. Figure 6 (Reference 5, Subsurface Drainage of Highways, by Barber) gives typical coefficients of permeability for clean, coarse-grained drainage material and the effect of various percentages of fines on permeability. Mixtures of about equal parts gravel with medium to coarse sand have a permeability of approximately 1 fpm. Single sized, clean gravel has a permeability exceeding 50 fpm. For approximate relationship of permeability versus effective grain size D_{10} , see Figure 1, Chapter 3.

4.2.2 DRAINAGE CAPACITY. Estimate the quantity of water which can be transmitted by a drainage blanket as follows:

$$Q = kiA$$

where:

q = quantity of flow, ft³/sec

k = permeability coefficient, ft/sec

i = average gradient in flow direction, ft/ft

A = cross sectional area of blanket, ft²

The gradient is limited by uplift pressures that may be tolerated at the point farthest from the outlet of the drainage blanket. Increase gradients and flow capacity of the blanket by providing closer spacing of drain pipes within the blanket.

4.2.2.1 PRESSURE RELIEF. See bottom panel of Figure 7 (Reference 6, Seepage Requirements of Filters and Pervious Bases, by Cedergren) for combinations of drain pipe spacing, drainage course thickness, and permeability required for control of flow upward from an underlying aquifer under an average vertical gradient of 0.4.

4.2.2.2 RATE OF DRAINAGE. See the top panel of Figure 7 (Reference 5) for time rate of drainage of water from a saturated base course beneath a pavement. Effective porosity is the volume of drainable water in a unit volume of soil. It ranges from 25 percent for a uniform material such as medium to coarse sand, to 15 percent for a broadly graded sand-gravel mixture.

4.2.2.3 DRAINAGE BLANKET DESIGN. The following guidelines should be followed:

- **GRADATION.** Design in accordance with Figure 4.
- **THICKNESS.** Beneath, structures require a minimum of 12 inches for each layer with a minimum thickness of 24 inches overall. If placed on wet, yielding, uneven excavation surface and subject to construction operation and traffic, minimum thickness shall be 36 inches overall.

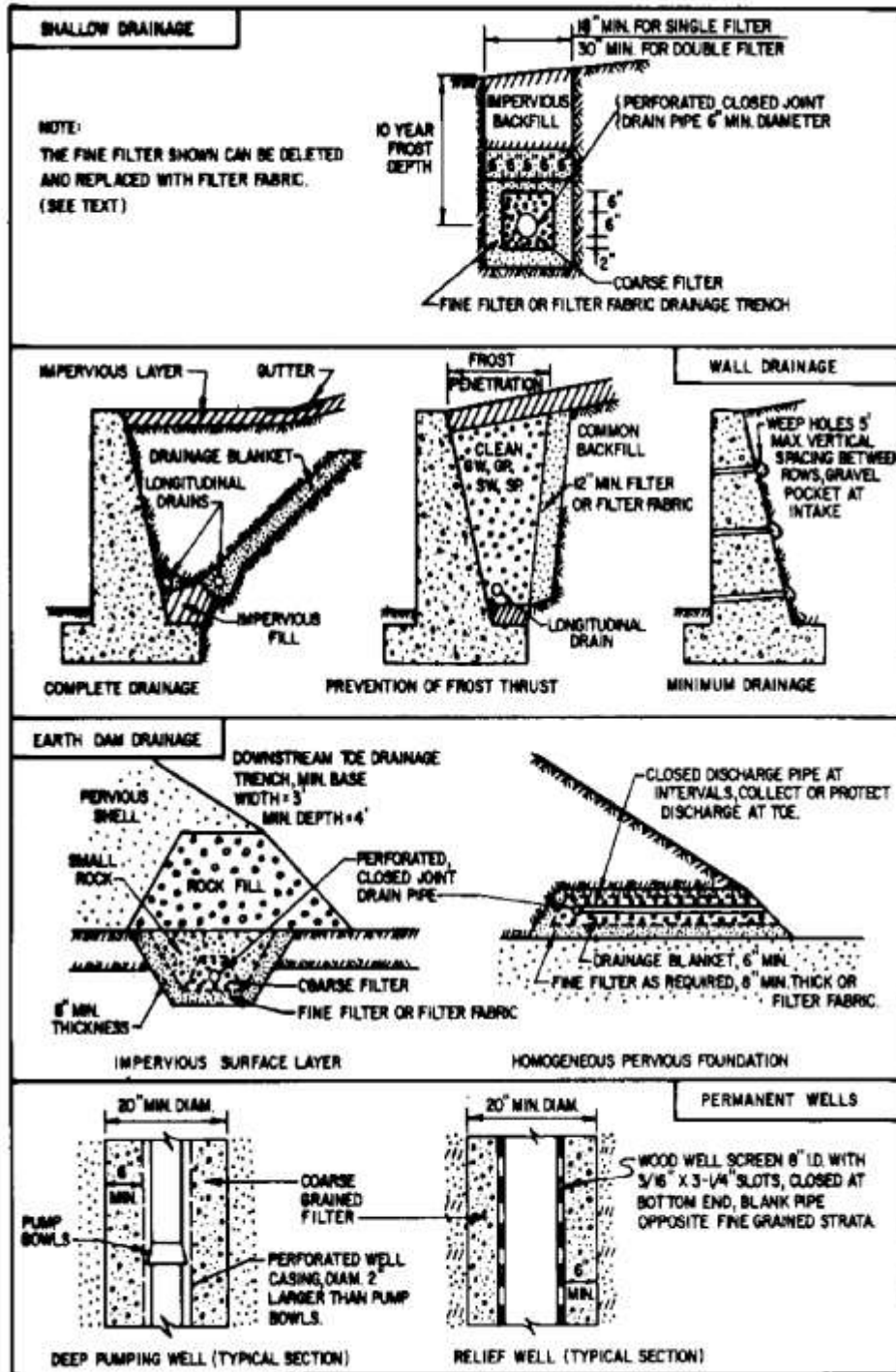

FIGURE 5
Typical Filter and Drainage Blanket Applications

Figure 5
Typical Filter and Drainage Blanket Applications

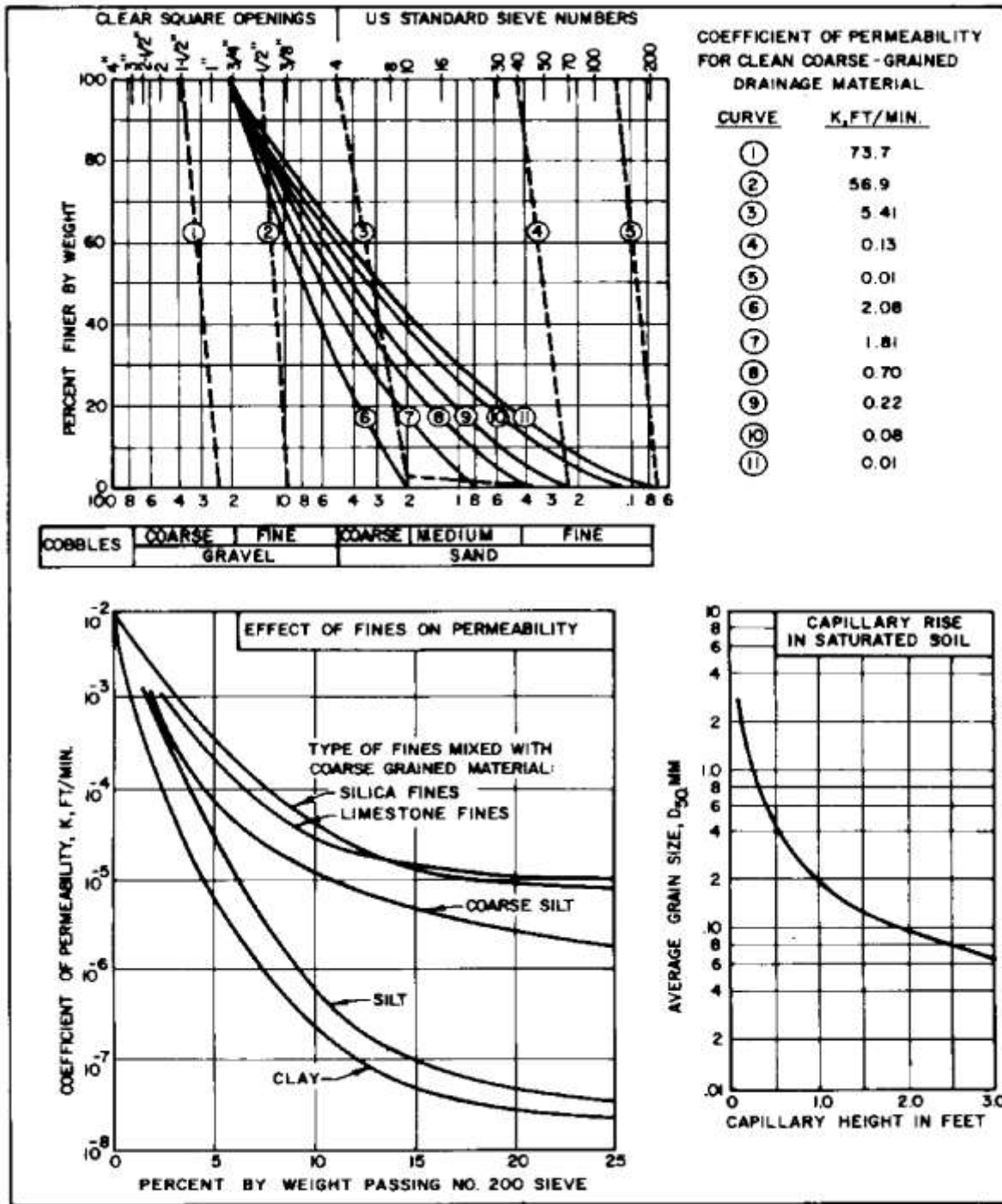

FIGURE 6
Permeability and Capillarity of Drainage Materials

Figure 6
Permeability and Capillarity of Drainage Materials

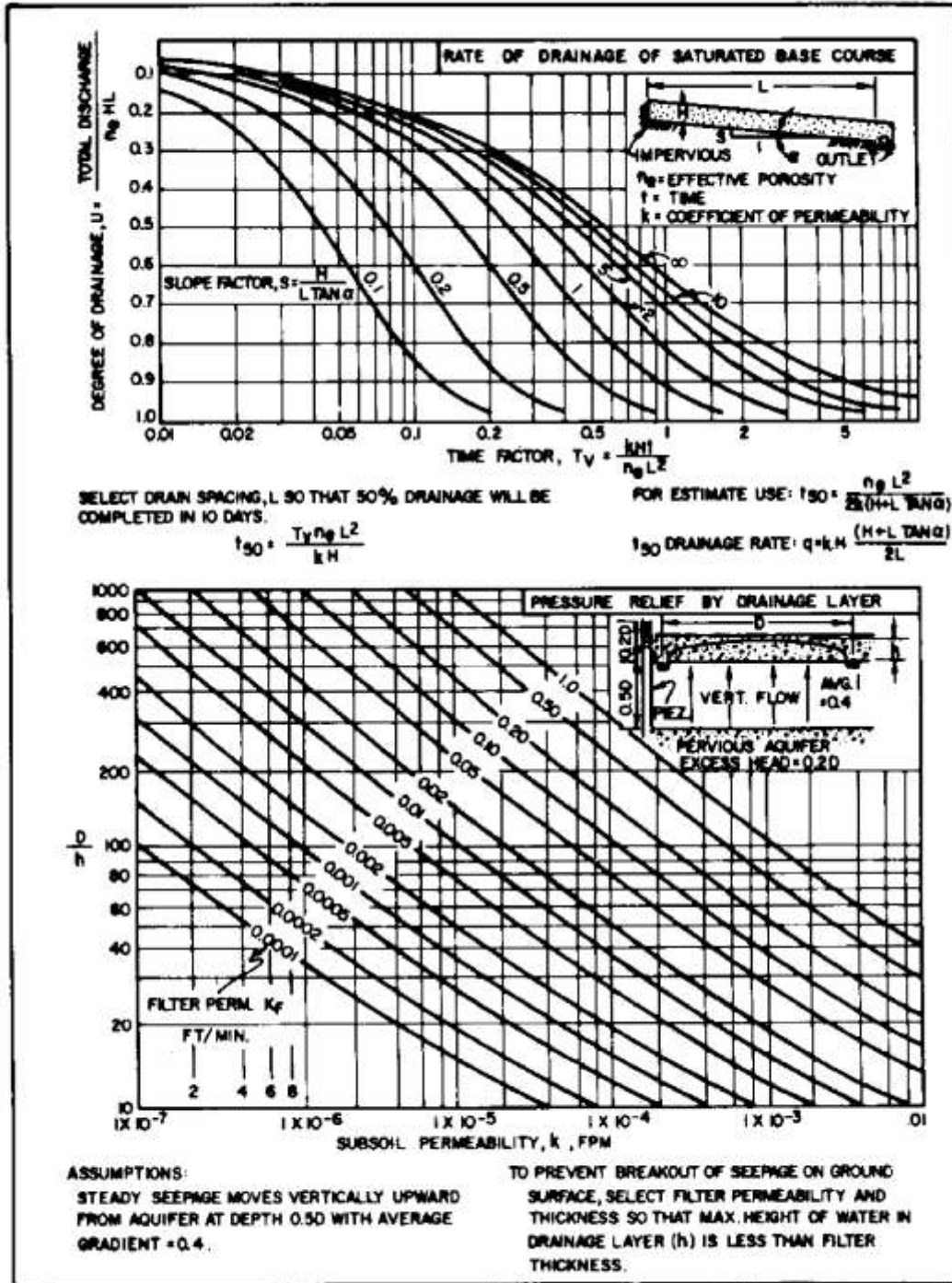

FIGURE 7
Analysis of Drainage Layer Performance

Figure 7
Analysis of Drainage Layer Performance

4.2.2.4 CHEMICAL CLOGGING. Filter systems (filter layers, fabrics, pipes) can become chemically clogged by ferruginous (iron) and carbonate depositions and incrustations. Where the permanent subdrainage system is accessible, pipes with larger perforations (3/8 inch) and increased thickness of filter layers can be used. For existing facilities, a weak solution of hydrochloric acid can be used to dissolve carbonates.

4.3 INTERCEPTING DRAINS. Intercepting drains consist of shallow trenches with collector pipes surrounded by drainage material, placed to intercept seepage moving horizontally in an upper pervious stratum. To design proper control drains, determine the drawdown and flow to drains by flow net analysis. Figure 8 shows typical placements of intercepting drains for roadways on a slope.

4.4 SHALLOW DRAINS FOR PONDED AREAS. Drains consisting of shallow stone trenches with collector pipes can be used to collect and control surface runoff. See Figure 9 (Reference 7, Seepage Into Ditches From a Plane Water Table Overlying a Gravel Substratum, by Kirkham; and Reference 8, Seepage Into Ditches in the Case of a Plane Water Table And an Impervious Substratum, by Kirkham) for determination of rate of seepage into drainage trenches. If sufficient capacity cannot be provided in trenches, add surface drainage facilities.

4.5 PIPES FOR DRAINAGE BLANKETS AND FILTERS. Normally, perforated wall pipes of metal or plastic or porous wall concrete pipes are used as collector pipes. Circular perforations should generally not be larger than 3/8 inch. Filter material must be graded according to the above guidelines. Pipes should be checked for strength. Certain deep buried pipes may need a cradle. Check for corrosiveness of soil and water; certain metal pipes may not be appropriate. Since soil migration may occur, even in the best designed systems, install cleanout points so that the entire system can be flushed and snaked.

5. WELLPOINT SYSTEMS AND DEEP WELLS

5.1 METHODS. Excavation below groundwater in soils having a permeability greater than 10^{-3} fpm generally requires dewatering to permit construction in the dry. For materials with a permeability between 10^{-3} and 10^{-5} fpm, the amount of seepage may be small but piezometric levels may need to be lowered in order to stabilize slopes or to prevent softening of subgrades. Drawdown for intermediate depths is normally accomplished by wellpoint systems or sumps. Deep drainage methods include deep pumping wells, relief wells, and deep sheeted sumps. These are appropriate when excavation exceeds a depth that can be dewatered efficiently by wellpoint systems alone or when the principal source of seepage is from lower permeable strata.

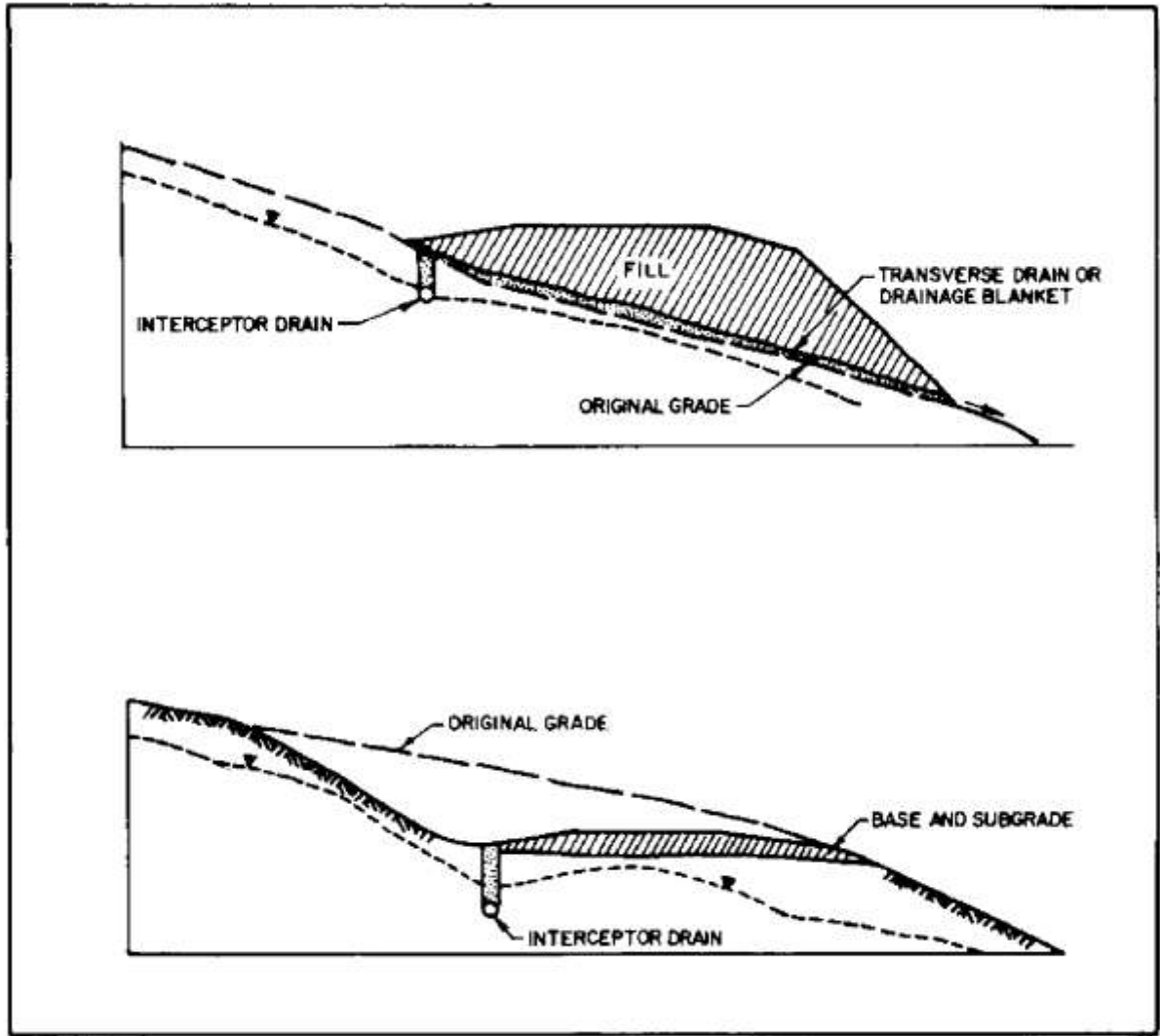

FIGURE 8
Intercepting Drains for Roadways on a Slope

Figure 8
Intercepting Drains for Roadways on a Slope

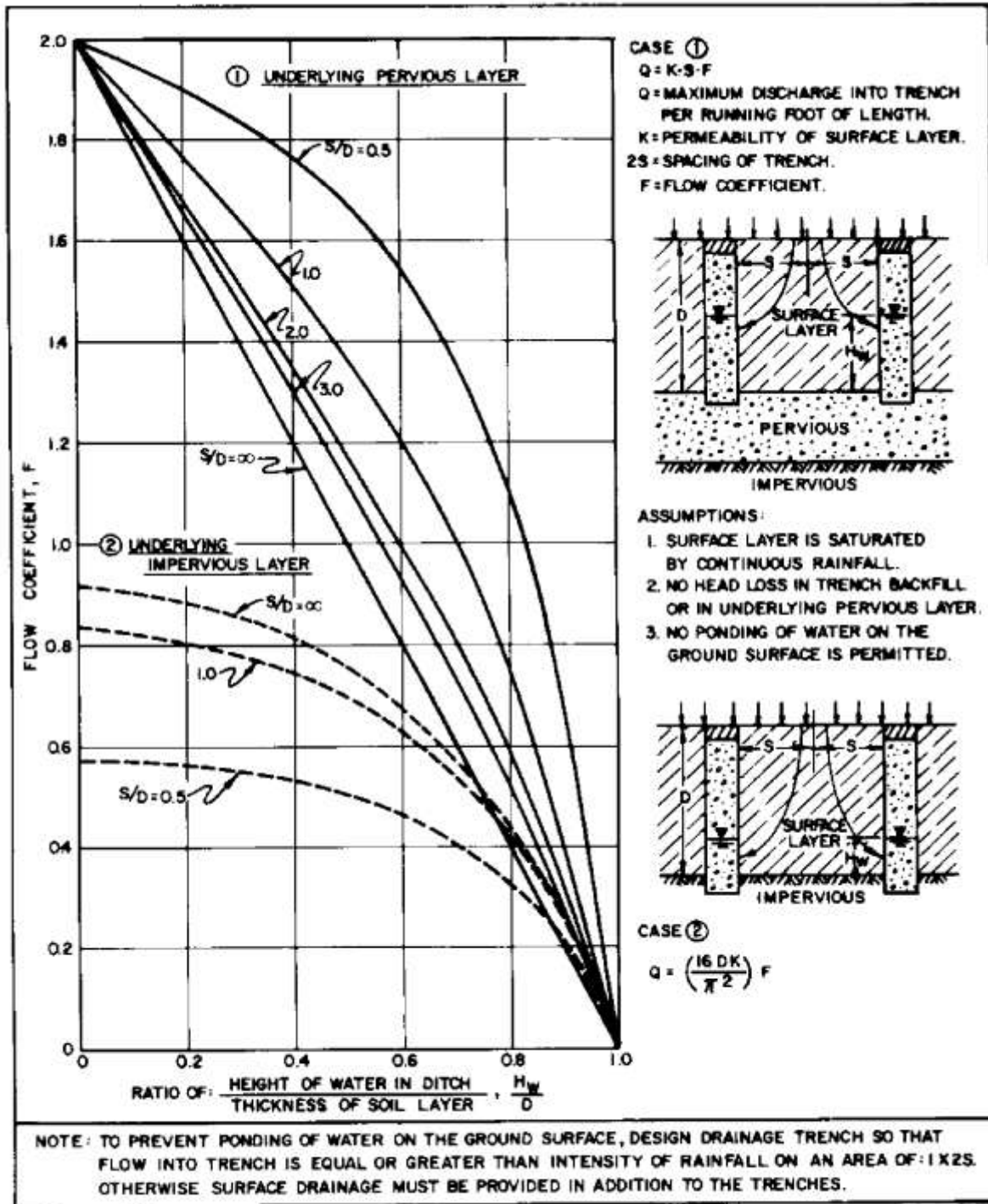

FIGURE 9
 Rate of Seepage into Drainage Trench

Figure 9
 Rate of Seepage into Drainage Trench

5.1.1 CONSTRUCTION CONTROLS. For important construction dewatering, install piezometers below the base of excavations and behind slopes or cofferdams to check on the performance and adequacy of drainage system.

5.1.2 SETTLEMENT EFFECTS. Where dewatering lowers the water levels in permeable strata adjacent to compressible soils, settlement may result.

5.2 WELLPOINT SYSTEMS. Wellpoints consist of 1-1/2 or 2-inch diameter pipes with a perforated bottom section protected by screens. They are jetted or placed in a prepared hole and connected by a header pipe to suction pumps.

5.2.1 APPLICABILITY. Wellpoints depend upon the water flowing by gravity to the well screen. Pumping methods for gravity drainage generally are not effective when the average effective grain size of a soil D_{10} is less than 0.05 mm. In varved or laminated soils where silty fine sands are separated by clayey silts or clay, gravity drainage may be effective even if the average material has as much as 50 percent smaller than 0.05 mm. Compressible, fine-grained materials containing an effective grain size less than 0.01 mm can be drained by providing a vacuum seal at the ground surface around the wellpoint, utilizing atmospheric pressure as a consolidating force. See Section 4 for limitations due to iron and carbonate clogging.

5.2.2 CAPACITY. Wellpoints ordinarily produce a drawdown between 15 and 18 feet below the center of the header. For greater drawdown, install wellpoints in successive tiers or stages as excavation proceeds. Discharge capacity is generally 15 to 30 gpm per point. Points are spaced between 3 and 10 feet apart. In finely stratified or varved materials, use minimum spacing of points and increase their effectiveness by placing sand in the annular space surrounding the wellpoint.

5.2.3 ANALYSIS. Wellpoint spacing usually is so close that the seepage pattern is essentially two dimensional. Analyze total flow and drawdown by flow net procedure.

For fine sands and coarser material, the quantity of water to be removed controls wellpoint layout. For silty soils, the quantity pumped is relatively small and the number and spacing of wellpoints will be influenced by the time available to accomplish the necessary drawdown.

5.3 SUMPS. For construction convenience or to handle a large flow in pervious soils, sumps can be excavated with soldier beam and horizontal wood lagging. Collected seepage is removed with centrifugal pumps placed within the sump. Analyze drawdown and flow quantities by approximating the sump with an equivalent circular well of large diameter. Sheeted sumps are infrequently used. Unsheeted sumps are far more common, and are used primarily in dewatering open shallow excavations in coarse sands, clean gravels, and rock.

5.4 ELECTRO-OSMOSIS. This is a specialized procedure utilized in silts and clays that are too fine-grained to be effectively drained by gravity or vacuum methods.

5.5 PUMPING WELLS. These wells are formed by drilling a hole of sufficient diameter to accommodate a pipe column and filter, installing a well casing, and placing filter material in the annular space surrounding the casing. Pumps may be either the turbine type with a motor at the surface and pipe column with pump bowls hung inside the well, or a submersible pump placed within the well casing.

5.5.1 APPLICATIONS. Deep pumping wells are used if (a) dewatering installations must be kept outside the excavation area, (b) large quantities are to be pumped for the full construction period, and (c) pumping must commence before excavation to obtain the necessary time for drawdown. See Figure 10 (bottom panel, Reference 9, Analysis of Groundwater Lowering Adjacent to Open Water, by Avery) for analysis of drawdown and pumping quantities for single wells or a group of wells in a circular pattern. Deep wells may be used for gravels to silty fine sands, and water bearing rocks. Bored shallow wells with suction pumps can be used to replace wellpoints where pumping is required for several months or in silty soils where correct filtering is critical.

5.5.2 SPECIAL METHODS. Ejector or eductor pumps may be utilized within wellpoints for lifts up to about 60 feet. The ejector pump has a nozzle arrangement at the bottom of two small diameter riser pipes which remove water by the Venturi principle. They are used in lieu of a multistage wellpoint system and if the large pumping capacity of deep wells is not required. Their primary application is for sands, but with proper control they can also be used in silty sands and sandy silts.

5.6 RELIEF WELLS. These wells are sand columns used to bleed water from underlying strata containing artesian pressures, and to reduce uplift forces at critical location. Relief wells may be tapped below ground by a collector system to reduce back pressures acting in the well.

5.6.1 APPLICATIONS. Relief wells are frequently used as construction expedients, and in situations where a horizontal drainage course may be inadequate for pressure relief of deep foundations underlain by varved or stratified soils or soils whose permeability increases with depth.

5.6.2 ANALYSIS. See Figure 11 for analysis of drawdown produced by line of relief wells inboard of a long dike. To reduce uplift pressures h_m midway between the wells to safe values, vary the well diameter, spacing, and penetration to obtain the best combination.

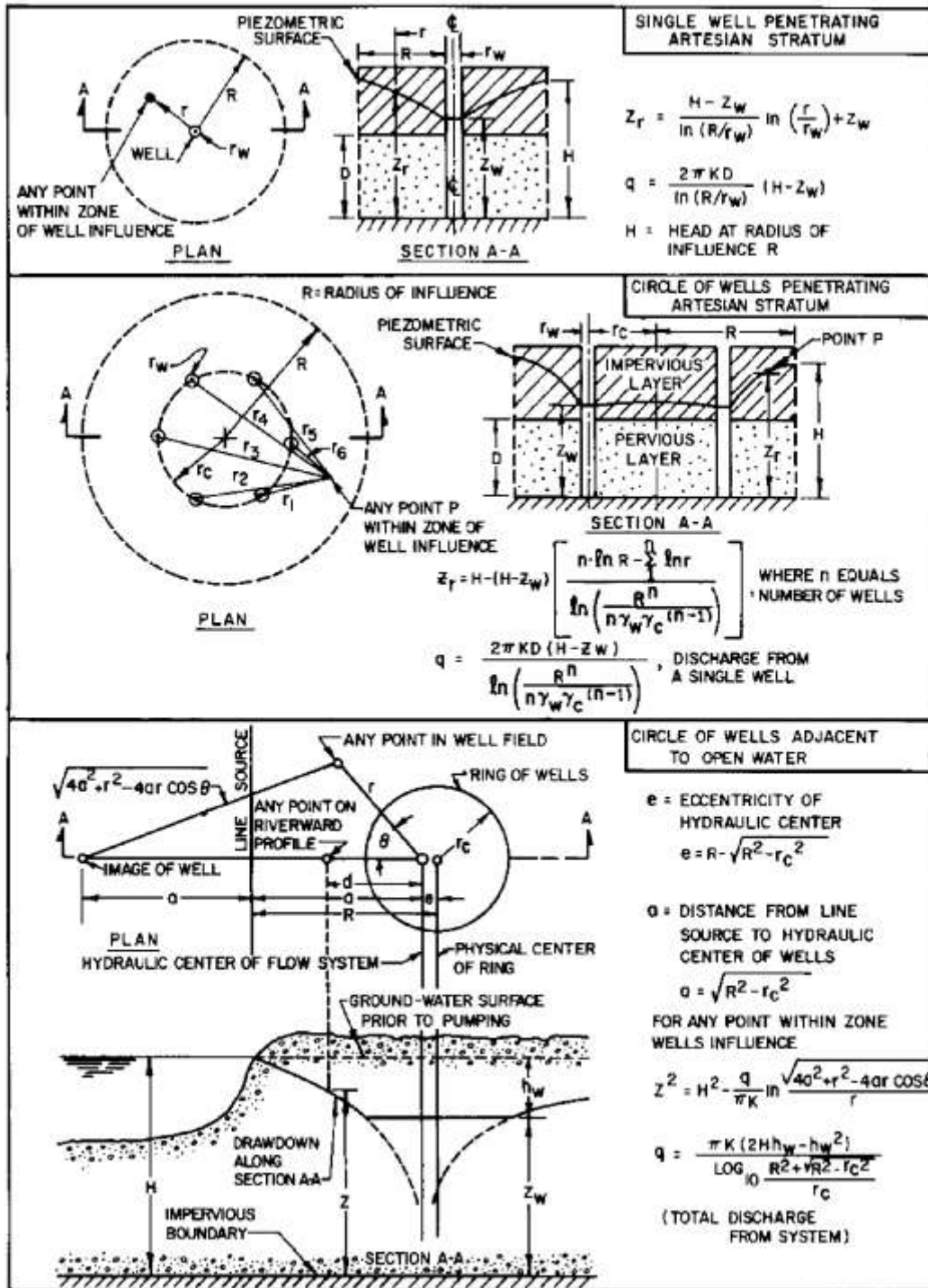

FIGURE 10
Groundwater Lowering by Pumping Wells

Figure 10
Groundwater Lowering by Pumping Wells

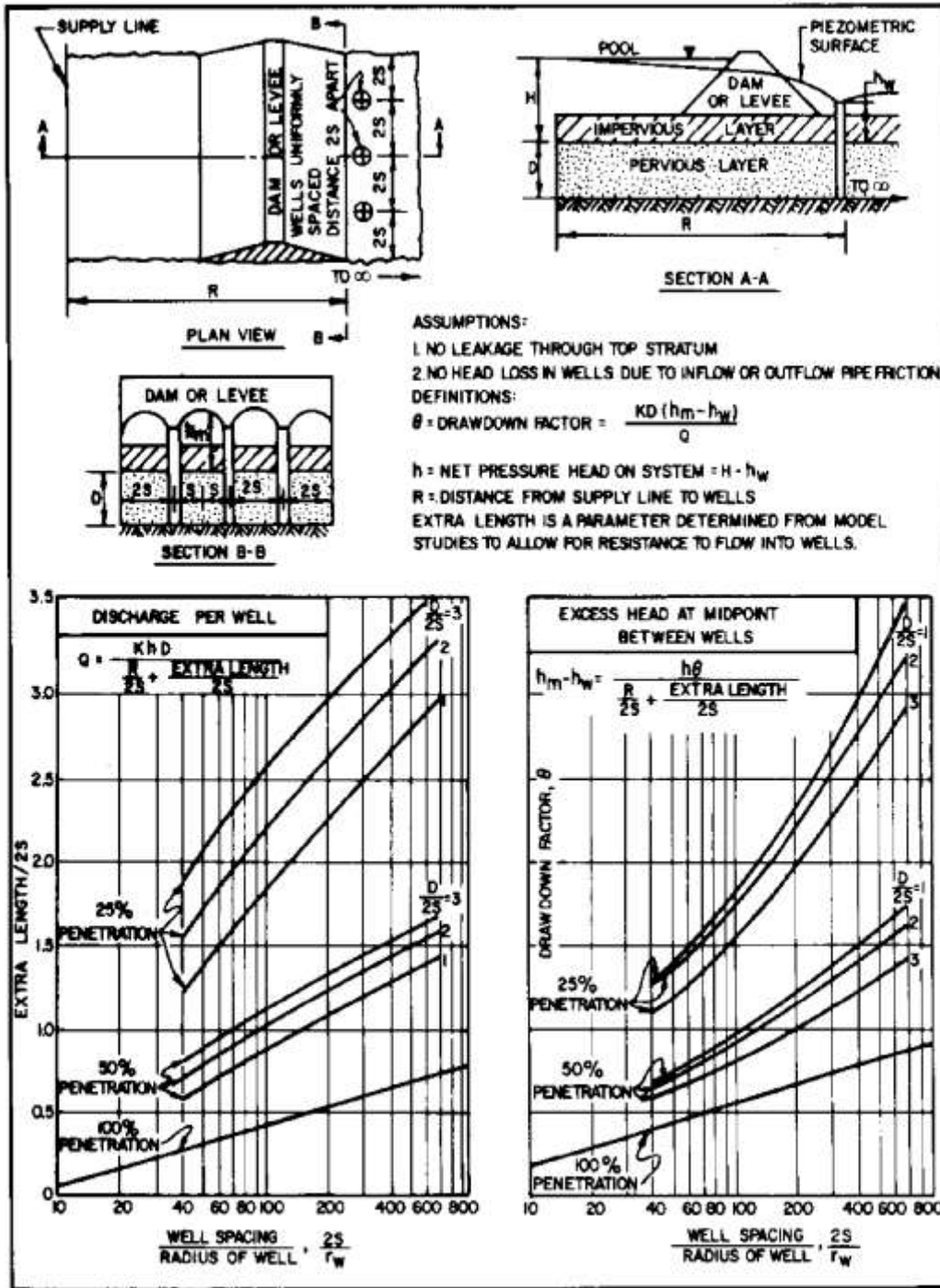

FIGURE 11
Drainage of Artesian Layer by Line of Relief Wells

Figure 11
Drainage of Artesian Layer by Line of Relief Wells

6. LININGS FOR RESERVOIRS AND POLLUTION CONTROL FACILITIES

6.1 PURPOSE. Linings are used to reduce water loss, to minimize seepage which can cause instability in embankments, and to keep pollutants from migrating to groundwater sources as in holding ponds at sewage treatment and chemical facilities, and in sanitary landfills.

6.2 TYPES. Table 2 lists types of linings appropriate where wave forces are insignificant. Where erosive forces are present, combine lining with slope protection procedure.

6.3 SUBDRAINAGE. If the water level in the reservoir may fall below the surrounding groundwater level, a permanent subdrainage system should be provided below the lining.

6.4 INVESTIGATION FOR LINING. Check any potential lining for reaction to pollutants (e.g., synthetic rubber is subject to attack by hydrocarbons), potential for insect attack (e.g., certain synthetic fabrics may be subject to termite attack), and the potential for borrowing animals breaching the lining.

7. EROSION CONTROL

7.1 GENERAL. The design of erosion controls must consider the volume of runoff from precipitation, the runoff velocity, and the amount of soil loss.

7.1.1 VOLUME OF RUNOFF. The volume of runoff depends on the amount of precipitation, ground cover, and topography. For guidance on evaluating the volume of runoff see Reference 12, *Urban Hydrology for Small Watersheds*, by the Soil Conservation Service.

7.1.2 AMOUNT OF SOIL LOSS. Soil losses can be estimated using the Universal Soil Loss Equation developed by the Soil Conservation Service:

$$A = EI \times (KLS)$$

where

A = computed soil loss per acre, in tons

EI = rainfall erosion index

K = soil erodibility factor

L = slope length factor

S = slope gradient factor

Method	Applicability and Procedures
Buried Plastic Liner	Impervious liner formed of black colored polyvinyl chloride plastic film. Where foundation is rough or rocky, place a layer 2 to 4 inches thick of fine-grained soil beneath liner. Seal liner sections by bonding with manufacturer's recommended solvent with 6-inch overlap at joints. Protect liner by 6-inch min. cover of fine grained soil. On slopes add a 6-inch layer of gravel and cobbles 3/4 to 3-inch size. Anchor liner in a trench at top of slope. Avoid direct contact with sunlight during construction before covering with fill and in completed installation. Usual thickness range of 20 to 45 mils (.020" to 045"). Items to be specified include Tensile Strength (ASTM D412), Elongation at Break (ASTM D412), Water Absorption (ASTM D471), Cold Bend (ASTM D2136), Brittleness Temperature (ASTM D746), Ozone Resistance (ASTM D1149), Heat Aging Tensile Strength and Elongation at Break (ASTM D412), Strength - Tear and Grab (ASTM D751).
Buried Synthetic Rubber Liner	Impervious liner formed by synthetic rubber, most often polyester reinforced. Preparation, sealing, protection, anchoring, sunlight, thickness, and ASTM standards are same as Buried Plastic Liner.
Bentonite Seal	Bentonite placed under water to seal leaks after reservoir filling. For placing under water, bentonite may be poured as a powder or mixed as a slurry and placed into the reservoir utilizing methods recommended by the manufacturer. Use at least 0.8 pounds of bentonite for each square foot of area, with greater concentration at location of suspected leaks. For sealing silty or sandy soils, bentonite should have no more than 10 percent larger than 0.05 mm; for gravelly and rocky materials, bentonite can have as much as 40 percent larger than 0.05 mm. For sealing channels with flowing water or large leaks, use mixture of 1/3 each of sodium bentonite, calcium bentonite, and sawdust.
Earth Lining	Lining generally 2 to 4 feet thick of soils having low permeability. Used on bottom and sides of reservoir extending to slightly above operating water levels. Permeability of soil should be no greater than about 2×10^{-6} fpm for water supply linings and 2×10^{-7} fpm for pollution control facility linings.
Thin Compacted Soil Lining with Chemical Dispersant	Dispersant is utilized to minimize thickness of earth lining required by decreasing permeability of the lining. Used where wave action is not liable to erode the lining. Dispersant, such as sodium tetraphosphate, is spread on a 6-inch lift of clayey silt or clayey sand. Typical rate of application is 0.05 lbs/sf. Chemical and soil are mixed with a mechanical mixer and compacted by sheepsfoot roller. Using a suitable dispersant, the thickness of compacted linings may be limited to about 1 foot; the permeability of the compacted soil can be reduced to 1/10 of its original value.

Table 2
Impermeable Reservoir Linings

EI, L, and S values should be obtained from local offices of the U.S. Soil Conservation Service. K values may be determined from published data on a particular locality. In the absence of such data, it may be roughly estimated from Figure 12 (after Reference 13, Erosion Control on Highway Construction, by the Highway Research Board).

7.2 INVESTIGATION. Where erosion can be expected during earthwork construction, on-site investigations should include: (1) field identification and classification for both agricultural textures and the Unified system, (2) sampling for grain size distribution, Atterberg limits and laboratory classification, and (3) determination of in-place densities.

7.3 SURFACE EROSION CONTROL. For typical erosion control practices see Table 3, (modified from Reference 13). General considerations to reduce erosion include:

7.3.1 CONSTRUCTION SCHEDULING. Schedule construction to avoid seasons of heavy rains. Winds are also seasonal, but are negligible in impact compared to water erosion.

7.3.2 Soil Type. Avoid or minimize exposure of highly erodible soils. Sands easily erode but are easy to trap. Clays are more erosion resistant, but once eroded, are more difficult to trap.

7.3.3 SLOPE LENGTH AND STEEPNESS. Reduce slope lengths and steepness to reduce velocities. Provide benches on slopes at maximum vertical intervals of 30 feet.

7.3.4 COVER. Cover quickly with vegetation, such as grass, shrubs and trees, or other covers such as mulches. A straw mulch applied at 2 tons/acre may reduce soil losses as much as 98% on gentle slopes. Other mulches include asphalt emulsion, paper products, jute, cloth, straw, wood chips, sawdust, netting of various natural and man-made fibers, and, in some cases, gravel.

7.3.5 SOIL SURFACE. Ridges perpendicular to flow and loose soil provide greater infiltration.

7.3.6 EXPOSED AREA. Minimize the area opened at any one time. Retain as much natural vegetation as possible. Leave vegetation along perimeters to control erosion and act as a sediment trap.

7.3.7 DIVERSION. Minimize flow over disturbed areas, such as by placing a berm at the top of a disturbed slope.

7.3.8 SPRINKLING. Control dust by sprinkling of exposed areas.

7.3.9 SEDIMENT BASINS. Construct debris basins to trap debris and silt before it enters streams.

7.4 CHANNEL LININGS. Table 4 presents guidelines for minimizing erosion of earth channels and grass covered channels (modified after Reference 14, Minimizing Erosion in Urbanizing Areas, by the Soil Conservation Service).

TABLE 3
Typical Erosion Control Practice





Treatment Practice	Advantages	Problems
FILL SLOPES		
<p>BERMS AT TOP OF EMBANKMENT</p> 	<p>Prevent runoff from embankment surface from flowing over face of fill Collect runoff for slope drains or protected ditch Can be placed as a part of the normal construction operation and incorporated into fill or shoulders</p>	<p>Cooperation of construction operators to place final lifts at edge or shaping into berm Difficult to compact outside lift when work is resumed Sediment buildup and berm and slope failure</p>
<p>SLOPE DRAINS</p> 	<p>Prevent fill slope erosion caused by embankment surface runoff Can be constructed of full or half section pipe, bituminous, metal, concrete, plastic, or other waterproof material Can be extended as construction progresses May be either temporary or permanent</p>	<p>Permanent construction as needed may not be considered desirable by contractor Removal of temporary drains may disturb growing vegetation Energy dissipation devices are required at the outlets</p>
<p>FILL BERMS OR BENCHES</p> 	<p>Slows velocity of slope runoff Collects sediments Provides access for maintenance Collects water for slope drains May utilize waste</p>	<p>Requires additional fill material if waste is not available May cause sloughing Additional construction area may be needed</p>
<p>SEEDING/MULCHING</p> 	<p>Timely application of mulch and seeding decreases the period a slope is subject to severe erosion Mulch that is cut in or otherwise anchored will collect sediment. The furrows made will also hold water and sediment</p>	<p>Seeding season may not be favorable Not 100 percent effective in preventing erosion Watering may be necessary Steep slopes or locations with high velocities may require supplemental treatment.</p>

Table 3
Typical Erosion Control Practice

TABLE 3 (continued)
Typical Erosion Control Practice





Treatment Practice	Advantages	Problems
PROTECTION OF ADJACENT PROPERTY		
 <p>BRUSH BARRIERS</p>	<p>Use slashing and logs from clearing operation Can be covered and seeded rather than removed Eliminates need for burning or disposal off right-of-way</p>	<p>May be considered unsightly in urban areas</p>
 <p>STRAW BALE BARRIERS</p>	<p>Straw is readily available in many areas When properly installed, they filter sediment and some turbidity from runoff</p>	<p>Requires removal Subject to vandal damage Flow is slow through straw requiring considerable area</p>
 <p>SEDIMENT TRAPS</p>	<p>Collect much of the sediment spill from fill slopes and storm drain ditches Inexpensive Can be cleaned and expanded to meet need</p>	<p>Does not eliminate all sediment and turbidity Space is not always available</p>
 <p>SEDIMENT POOLS</p>	<p>Can be designed to handle large volumes of flow Both sediment and turbidity are removed May be incorporated into permanent erosion control plan</p>	<p>Requires prior planning, additional construction area and/or flow easement If removal is necessary, can present a major effort during final construction stage Clean-out volumes can be large Access for clean-out not always convenient; Anti-seepage baffles required for permanent construction</p>
 <p>FENCE TRAP</p>	<p>Low cost Temporary measure can be erected with minimum supervision</p>	<p>Some maintenance needed depending on length of time in place</p>

Table 3 (continued)
Typical Erosion Control Practice

TABLE 3 (continued)
Typical Erosion Control Practice



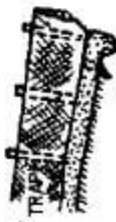

Treatment Practice	Advantages	Problems
PROTECTION OF ADJACENT PROPERTY (continued)		
<p>ENERGY DISSIPATORS</p> 	<p>Slow velocity to permit sediment collection and to minimize channel erosion off project</p>	<p>Collects debris and requires cleaning Requires special design and construction of large shot rock or other suitable material from project</p>
<p>LEVEL SPREADERS</p> 	<p>Spreads channel or pipe flow to sheet flow Avoids channel easements and construction off project Simple to construct</p>	<p>Adequate spreader length may not be available Sodding of overflow berm is usually required Must be a part of the permanent erosion control effort Maintenance forces must maintain spreader until no longer required</p>
PROTECTION OF STREAM		
<p>CONSTRUCTION DIKE</p> 	<p>Permits work to continue during normal stream stages Controlled flooding can be accomplished during periods of inactivity</p>	<p>Usually requires pumping of work site water into sediment pond Subject to erosion from stream and from direct rainfall on dike</p>
<p>COFFEROAM</p> 	<p>Work can be continued during most anticipated stream conditions Clear water can be pumped directly back into stream No material deposited in stream</p>	<p>Expensive</p>
<p>TEMPORARY STREAM CHANNEL CHANGE</p>	<p>Prepared channel keeps normal flows away from construction</p>	<p>New channel usually will require protection Stream must be returned to old channel and temporary channel refilled</p>

Table 3 (continued)
Typical Erosion Control Practice

TABLE 3 (continued)
Typical Erosion Control Practice



Treatment Practice	Advantages	Problems
<p>PROTECTION OF STREAM (continued)</p> <p>RIP RAP</p> 	<p>Sacked sand with cement or stone easy to stockpile and place Can be installed in increments as needed</p>	<p>Expensive</p>
<p>TEMPORARY CULVERTS FOR MAUL ROADS</p> 	<p>Eliminates stream turbulence and turbidity Provides unobstructed passage for fish and other aquatic life Capacity for normal flow can be provided with storm water flowing over the roadway</p>	<p>Space not always available without conflicting with permanent structure work May be expensive, especially for larger sizes of pipe Subject to washout</p>
<p>ROCK-LINED LOW-LEVEL CROSSING</p> 	<p>Minimizes stream turbidity Inexpensive May also serve as ditch check or sediment trap</p>	<p>May not be fordable during rainstorms During periods of low flow, passage of fish may be blocked</p>

Table 3 (continued)
Typical Erosion Control Practice

TABLE 3 (continued)
Typical Erosion Control Practice





Treatment Practice	Advantages	Problems
DITCHES		
<p>CHECK DAMS</p> 	<p>Maintains low velocities Catches sediment Can be constructed of logs, shot rock, lumber, masonry or concrete, gablons, sand bags</p>	<p>Close spacing on steep grades Require clean-out Unless keyed at sides and bottom, erosion may occur</p>
<p>SEDIMENT TRAPS/ STRAW BALE FILTERS</p> 	<p>Can be located as necessary to collect sediment during construction Clean-out often can be done with on-the-job equipment Simple to construct</p>	<p>Little direction on spacing and size Sediment disposal may be difficult Specification must include provisions for periodic clean-out May require seeding, sodding or pavement when removed during final cleanup</p>
<p>SODDING</p> 	<p>Easy to place with a minimum of preparation Can be repaired during construction Immediate protection May be used on sides of paved ditches to provide increased capacity</p>	<p>Requires water during first few weeks Sod not always available Will not withstand high velocity or severe abrasion from sediment load</p>
<p>SEEDING WITH MULCH AND MATTING</p> 	<p>Usually least expensive Effective for ditches with low velocity Easily placed in small quantities with inexperienced personnel</p>	<p>Will not withstand medium to high velocity Requires anchoring</p>
<p>PAVING, RIPRAP, RUBBLE</p>	<p>Effective for high velocities May be part of the permanent erosion control effort</p>	<p>Cannot always be placed when needed because of construction traffic and final grading and dressing Initial cost is high</p>

Table 3 (continued)
Typical Erosion Control Practice

TABLE 3 (continued)
Typical Erosion Control Practice





Treatment Practice	Advantages	Problems
ROADWAY SURFACE		
<p>CROWNING TO DITCH OR SLOPING TO SINGLE BERM</p> 	<p>Directing the surface water to a prepared or protected ditch minimizes erosion</p>	<p>Requires good construction procedures Can cause local stability problems (sloughing)</p>
<p>COMPACTION</p>	<p>The final lift of each day's work should be well compacted and bladed to drain to ditch or berm section Loose or uncompacted material is more subject to erosion</p>	<p>Requires good construction procedures</p>
<p>AGGREGATE COVER</p> 	<p>Minimizes surface erosion Permits construction traffic during adverse weather May be used as part of permanent base construction</p>	<p>Requires reworking and compaction if exposed for long periods of time Loss of surface aggregates can be anticipated</p>
<p>SEED/MULCH</p> 	<p>Minimizes surface erosion</p>	<p>Must be removed or is lost when construction of pavement is commenced</p>
<p>STONE FILLED GABION WALL</p> 	<p>Permits steeper slope No special backfill required Self draining</p>	<p>High cost Requires special techniques to install properly</p>

Table 3 (continued)

Typical Erosion Control Practice

TABLE 3 (continued)
Typical Erosion Control Practice

Treatment Practice	Advantages	Problems
<p>CUT SLOPES</p> <p>BERM AT TOP OF CUT</p> 	<p>Diverts water from cut Collects water for slope drains/paved ditches May be constructed before grading is started</p>	<p>Access to top of cut Difficult to build on steep natural slope or rock surface Concentrates water and may require channel protection or energy dissipation devices Can cause water to enter ground, resulting in sloughing of the cut slope</p>
<p>DIVERSION DIKE</p> 	<p>Collects and diverts water at a location selected to reduce erosion potential May be incorporated in the permanent project drainage</p>	<p>Access for construction May be continuing maintenance problem if not paved or protected Disturbed material or berm is easily eroded</p>
<p>SLOPE BENCHES</p> 	<p>Slows velocity of surface runoff Collects sediment Provides access to slope for seeding, mulching, and maintenance Collects water for slope drains or may divert water to natural ground</p>	<p>May cause sloughing of slopes if water infiltrates Requires additional construction area Not always possible due to poor material, etc. Requires maintenance to be effective Increases excavation quantities</p>
<p>SLOPE DRAINS (PIPE, PAVED, ETC.)</p> 	<p>Prevents erosion on the slope Can be temporary or part of permanent construction Can be constructed or extended as grading progresses</p>	<p>Requires supporting effort to collect water Permanent construction is not always compatible with other project work Usually requires some type of energy dissipation</p>

Table 3 (continued)
Typical Erosion Control Practice

TABLE 3 (continued)
Typical Erosion Control Practice



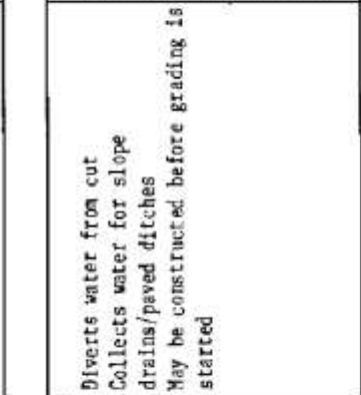
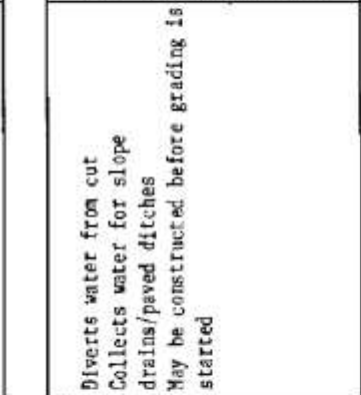
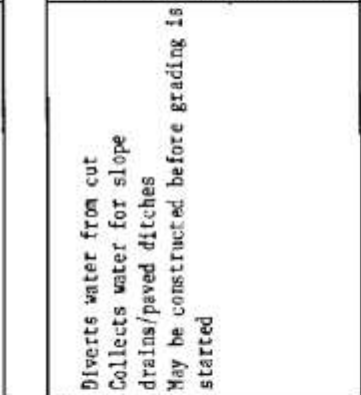
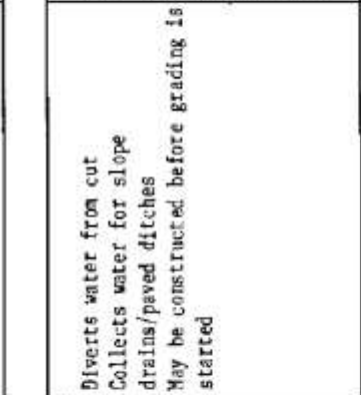

Treatment Practice	Advantages	Problems
<p>CUT SLOPES (continued)</p> <p>SEEDING/MULCHING</p> 	<p>The end objective is to have a completely grassed slope. Early placement is a step in this direction. The mulch provides temporary erosion protection until grass is rooted. Temporary or permanent seeding may be used. Mulch should be anchored. Larger slopes can be seeded and mulched with smaller equipment if stage techniques are used.</p>	<p>Difficult to schedule high production units for small increments Time of year may be less desirable May require supplemental water Contractor may perform this operation with untrained or inexperienced personnel and inadequate equipment if stage seeding is required</p>
<p>SODDING</p> 	<p>Provides immediate protection Can be used to protect adjacent property from sediment and turbidity</p>	<p>Difficult to place until cut is complete Sod not always available May be expensive</p>
<p>SLOPE PAVEMENT, RIPRAP</p> 	<p>Provides immediate protection for high risk areas and under structures May be cast in place or off site</p>	<p>Expensive Difficult to place on high slopes May be difficult to maintain</p>
<p>TEMPORARY COVER</p> 	<p>Plastics are available in wide rolls and large sheets that may be used to provide temporary protection for cut or fill slopes Easy to place and remove Useful to protect high risk areas from temporary erosion</p>	<p>Provides only temporary protection Original surface usually requires additional treatment when plastic is removed Must be anchored to prevent wind damage</p>

Table 3 (continued)
Typical Erosion Control Practice

TABLE 3 (continued)
Typical Erosion Control Practice



Treatment Practice	Advantages	Problems
CUT SLOPES (continued)		
<p>SERRATED SLOPE</p> 	<p>Lowers velocity of surface runoff Collects sediment Holds moisture Minimizes amount of sediment reaching roadside ditches</p>	<p>May cause minor sloughing if water infiltrates Construction compliance</p>
<p>FABRIC MATS</p> 	<p>Effective for moderate to high embankment when crown vetch plantings are used Has lower cost features over other methods</p>	<p>Requires anchoring time to promote plant growth. May require periodic maintenance</p>
BORROW AREAS		
<p>SELECTIVE GRADING AND SHAPING</p>	<p>Water can be directed to minimize off-site damage Flatter slopes enable mulch to be cut into soil</p>	<p>May not be most economical work method for contractor</p>
<p>STRIPPING AND REPLACING OF TOPSOIL</p>	<p>Provides better seed bed Conventional equipment can be used to stockpile and spread topsoil</p>	<p>May restrict volume of material that can be obtained for a site Topsoil stockpiles must be located to minimize sediment damage Cost of rehandling material</p>
<p>DINES, BERMS DIVERSION DITCHES SETTLING BASINS SEDIMENT TRAPS SEEDING & MULCH</p>	<p>See other practices</p>	<p>See other practices</p>

Table 3 (continued)
Typical Erosion Control Practice

Permissible Velocity (feet/sec)				
Soil Type	Bare Channel	With Channel Vegetation		
		6" to 10" in height	11" to 24" in height	Over 30" in height
Sand, silt, sandy loam, silty loam	1.5	2.0 to 3.0	2.5 to 3.5	3.0 to 4.0
Silty clay loam, silty clay	2.0	3.0 to 4.0	3.5 to 4.5	4.0 to 5.0
Clay	2.5	3.0 to 5.0	3.0 to 5.5	3.0 to 6.0

Table 4

Limiting Flow Velocities to Minimize Erosion

7.5 SEDIMENT CONTROL. Typical sediment control practices are included in Table 3.

7.5.1 TRAPS. Traps are small and temporary, usually created by excavating and/or diking to a maximum height of five feet. Traps should be cleaned periodically.

7.5.2 PONDS.

7.5.2.1 SIZE THE OUTLET STRUCTURE to accept the design storm.

7.5.2.2 SIZE THE POND LENGTH, WIDTH AND DEPTH to remove the desired percentage of sediment. See Figure 13 (modified after Reference 15, Trap Efficiency of Reservoirs, by Brune). For design criteria see Reference 16, Reservoir Sedimentation, by Gottschalk.

7.5.2.3 IF POND IS PERMANENT, compute volume of anticipated average annual sedimentation by the Universal Soil Loss Equation. Multiply by the number of years between pond cleaning and by a factor of safety. This equals minimum required volume below water level. Dimensions of the pond can then be calculated based on the available area. The design depth of the pond should be approximately three to five feet greater than the calculated depth of sediment at the time of clearing.

7.6 RIPRAP PROTECTION. Frequently coarse rock is placed on embankments where erodible soils must be protected from fast currents and wave action. When coarse rock is used, currents and waves may wash soil out from under the rock and lead to undermining and failure. Soil loss under rock slopes can be prevented by the use of filter fabrics or by the placement of a filter layer of intermediate sized material between the soil and rock. In some cases soil loss can be prevented by the use of well-graded rock containing suitable fines which work to the bottom during placement. For further guidance see Reference 17, Tentative Design Procedure for Rip Rap Lined Channels, by the Highway Research Board. For determining rock sizes and filter requirements use Figure 14 (Reference 18, Design of Small Dams, by the Bureau of Reclamation).

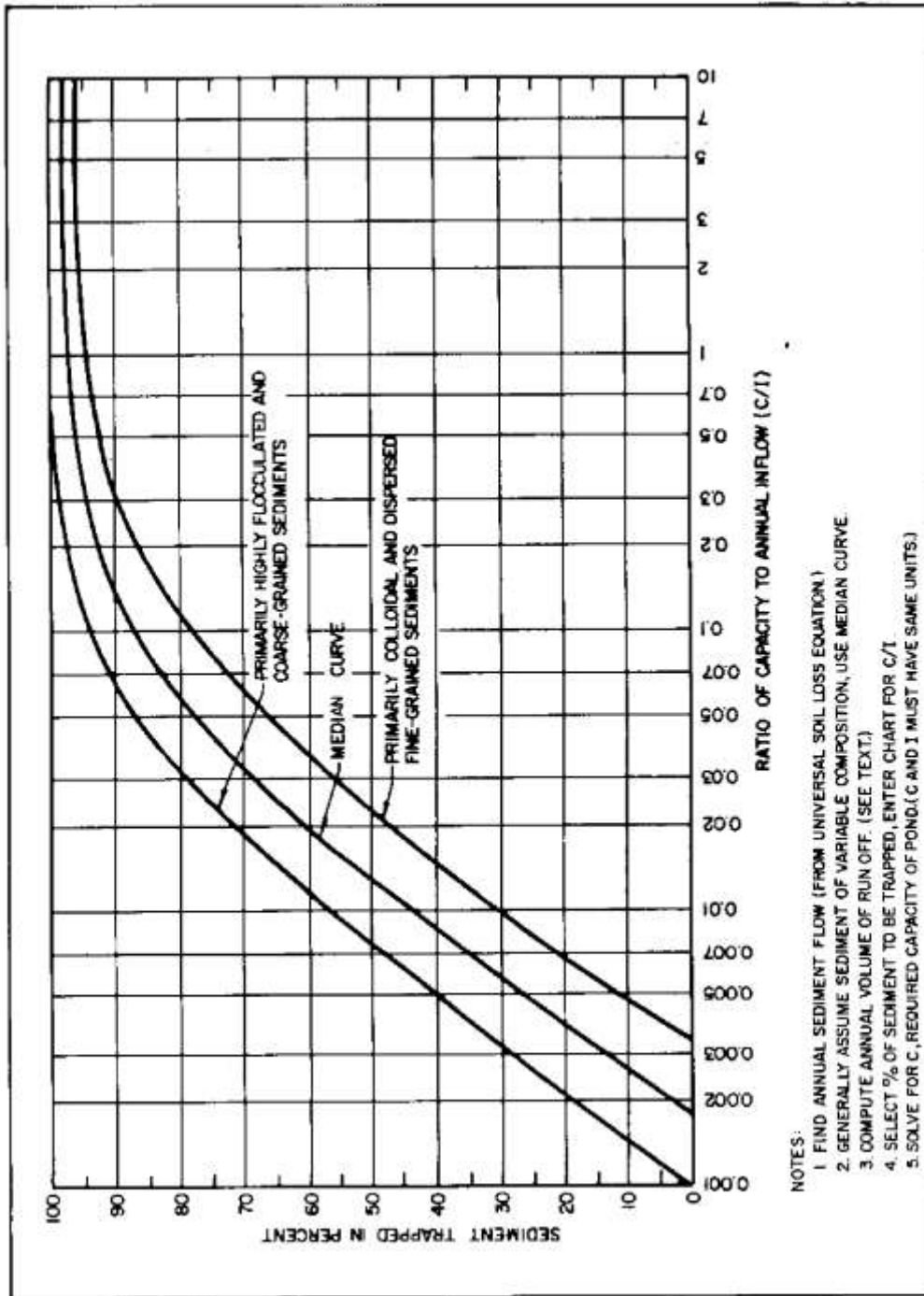

FIGURE 13
Capacity of Sediment Control Ponds

Figure 13

Capacity of Sediment Control Ponds

Example Calculation

Annual soil loss in watershed = 0.9 acre-feet/year (from Universal Soil Loss Equation or other method, i.e. design charts)

Desired pond efficiency = 70% or 0.63 acre-feet of sediment trapped each year.

Annual volume of runoff from watershed draining into proposed pond = 400 acre-feet/yr.

For 70% efficiency using median curve $C/I = 0.032$

Required pond capacity $C = 0.032 \times 400 = 12.8$ acre-feet.

Assuming average depth of pond of 6 ft, required pond area about 2.1 acres. Pond should be cleaned when capacity reduced 50%.

(Note: Trap efficiency decreases as volume of pond decreases; this has not been considered in the example.)

Volume available for sediment = $50\% \times 12.8 = 6.4$ acre-feet.

Years between cleaning = $6.4/0.63 =$ approximately 10 years

Figure 13 (continued)
Capacity of Sediment Control Ponds

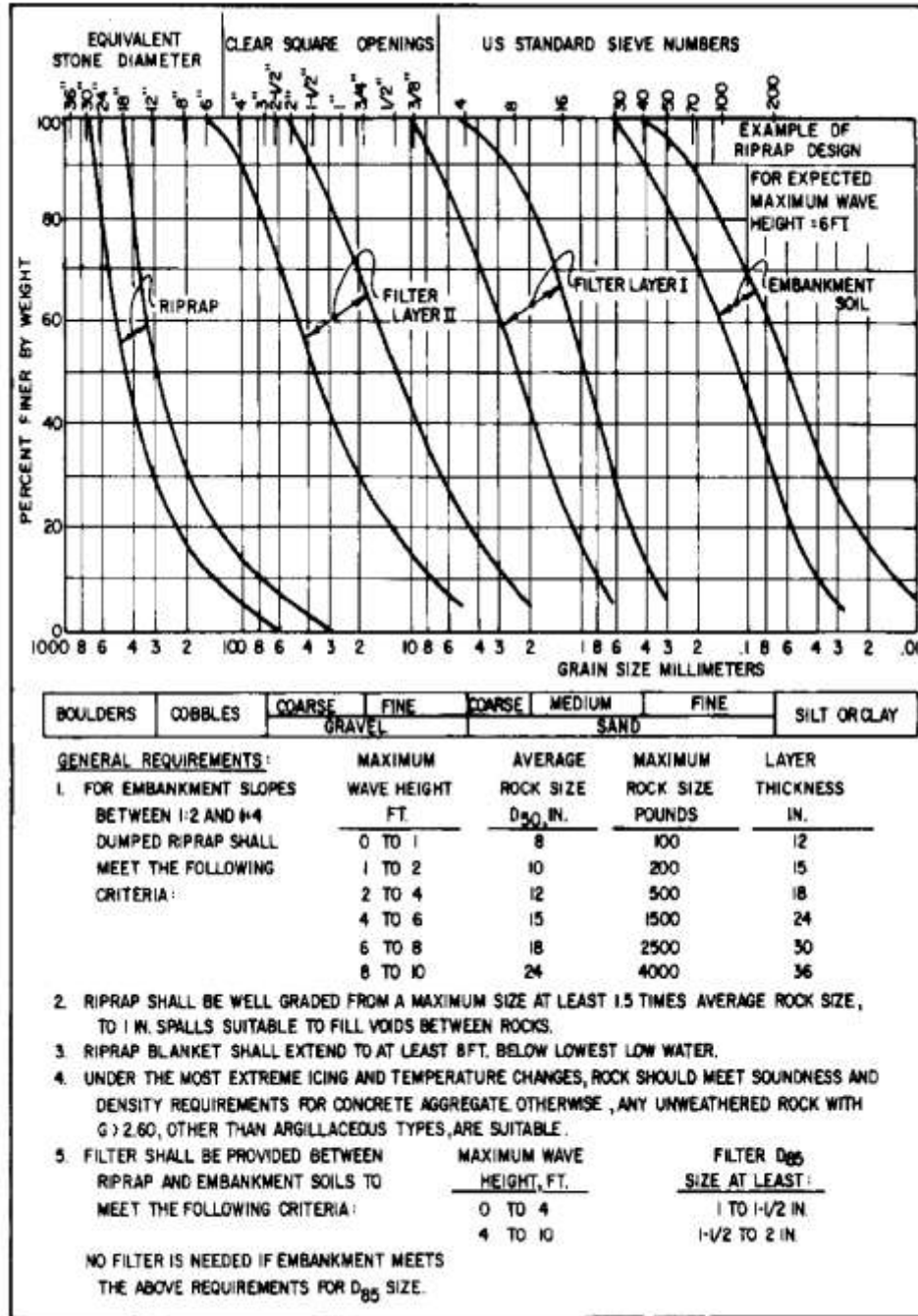

FIGURE 14
Design Criteria for Riprap and Filter on Earth Embankments

Figure 14
Design Criteria for Riprap and Filter on Earth Embankments

FILTER MAY NOT BE REQUIRED IF EMBANKMENT CONSISTS OF CH OR CL WITH LL) 30, RESISTANT TO SURFACE EROSION. IF A FILTER IS USED IN THIS CASE IT ORDINARILY MEETS FILTER CRITERIA AGAINST RIPRAP ONLY.

IF EMBANKMENT CONSISTS OF NONPLASTIC SOILS WHERE SEEPAGE WILL MOVE FROM EMBANKMENT AT LOW WATER, 2 FILTER LAYERS MAY BE REQUIRED WHICH SHALL MEET FILTER CRITERIA AGAINST BOTH EMBANKMENT AND RIPRAP. (EXAMPLE IS SHOWN ABOVE).

MINIMUM THICKNESS OF SINGLE LAYER FILTERS ARE AS FOLLOWS	MAXIMUM WAVE HEIGHT, FEET	FILTER THICKNESS, INCHES
DOUBLE FILTER LAYERS SHOULD BE AT LEAST 6 INCHES THICK	0 TO 4	6
	4 TO 8	9
	8 TO 12	12

Figure 14 (continued)
Design Criteria for Riprap and Filter on Earth Embankments

8. REFERENCES

1. Lee, E. W., Security from Under Seepage of Masonry Dams on Earth Foundations, Transactions, ASCE, Volume 100, Paper 1919, 1935.
2. Marsland, A., Model Experiments to Study the Influence of Seepage on the Stability of a Sheeted Excavation in Sand, Geotechnique, 1952-1953.
3. Calhoun, C. C., Jr., Compton, J. R., Strohm, W. E. Jr., Performance of Plastic Filter Cloths as a Replacement for Granular Materials, Highway Research Record Number 373, Highway Research Board, 1971.
4. Koerner, R. M. and Welsh, J. P., Construction and Geotechnical Engineering Using Synthetic Fabrics, John Wiley & Sons, Inc., 1980.
5. Barber, E. W., Subsurface Drainage of Highways, Highway Research Board Bulletin 209, Highway Research Board, Washington, D.C.
6. Cedergen, H. R., Seepage Requirements of Filters and Pervious Bases, Journal of the Soil Mechanics and Foundation Division, ASCE, Vol. 86, No. SM5, 1960.
7. Kirkham, D., Seepage Into Ditches From a Plane Water Table Overlying a Gravel Substratum, Journal of Geophysical Research, American Geophysical Union, Washington, D.C., April, 1960.
8. Kirkham, D., Seepage Into Ditches in the Case of a Plane Water Table and an Impervious Substratum, Transactions, American Geophysical Union, Washington, D.C., June, 1950.
9. Avery, S. B., Analysis of Groundwater Lowering Adjacent to Open Water, Proceedings, ASCE, Vol 77, 1951.
10. Corps of Engineers, Soil Mechanics Design, Seepage Control, Engineering Manual, Civil Works Construction, Chapter I, Part CXIX, Department of the Army.
11. Cold Regions Research and Engineering Laboratory, Wastewater Stabilization Pond Linings, Special Report 28, Department of the Army, November, 1978.
12. Soil Conservation Service, U. S. Department of Agriculture, Urban Hydrology for Small Watersheds, Technical Release No. 55, Engineering Division, 1975.
13. Highway Research Board, Erosion Control on Highway Construction, National Cooperative Highway Research Program, Synthesis of Highway Practice 18, 1973.
14. Soil Conservation Service, U. S. Department of Agriculture, Minimizing Erosion in Urbanizing Areas, Madison, WI, 1972.
15. Brune, G. M., Trap Efficiency of Reservoirs, Transactions, American Geophysical Union, Volume 34, No. 3, June, 1953.
16. Gottschalk, L. C., Reservoir Sedimentation, Handbook of Applied Hydrology, Chow, Ed., Section 17-I, McGraw-Hill Book Company, 1964.

17. Highway Research Board, Tentative Design Procedure for Rip-Rap – Lined Channels, National Cooperative Highway Research Program Report 108, Washington, DC, 1970.

18. Bureau of Reclamation, Design of Small Dams, U.S. Department of the Interior, U. S. Government Printing Office, 1973.

19. Naval Facilities Engineering Command, Design Manuals (DM) and Publications (P).

DM-5.03 Drainage Systems

DM-21.06 Airfield Pavement Design for Frost Conditions and Subsurface Drainage

P-418 Dewatering and Groundwater Control