



**PDHonline Course C782 (2 PDH)**

---

## **An Introduction to Security Fences**

*Instructor: J. Paul Guyer, P.E., R.A., Fellow ASCE, Fellow AEI*

**2020**

**PDH Online | PDH Center**

5272 Meadow Estates Drive  
Fairfax, VA 22030-6658  
Phone: 703-988-0088  
[www.PDHonline.com](http://www.PDHonline.com)

An Approved Continuing Education Provider

# **An Introduction to Security Fences**

*J. Paul Guyer, P.E., R.A.*

## **CONTENTS**

### **1. INTRODUCTION**

### **2. FENCING**

(This publication is adapted from the *Unified Facilities Criteria* of the United States government which are in the public domain, have been authorized for unlimited distribution, and are not copyrighted.)

(Figures, tables and formulas in this publication may at times be a little difficult to read, but they are the best available. **DO NOT PURCHASE THIS PUBLICATION IF THIS LIMITATION IS UNACCEPTABLE TO YOU.**)

## **1. INTRODUCTION**

**1.1 PURPOSE.** This publication provides a unified approach for the design, selection, and installation of security fences.

**1.2 APPLICABILITY.** This document applies to all construction, renovation, and repair projects including expeditionary or temporary construction that include security fencing and gates. Consult with current policies, location of facility, and threat level for specific requirements.

**1.3 SECURITY FENCES AND GATES.** Security fences and gates are installed and used primarily to define the perimeter of protected areas, such as restricted areas, controlled areas, entry control/access control points, installation perimeters, and to provide a physical and psychological deterrent to entry and preventing unauthorized personnel from entering a protected area.

**1.4 SCOPE AND GUIDANCE.** Security managers, security personnel, planners, designers, architects, and engineers may use this publication when evaluating existing and providing new security fences and gates. Technical information considered generally known to security professionals and engineers, or readily available in technical references has not been included. This document is not intended to address procedural issues such as threat levels or to provide specific design criteria such as vehicle impact forces.

**1.4.1 DRAWINGS.** The notional examples provided in the body of this publication are for illustration and must be modified for the specific application, environmental conditions, and local constraints. The details and drawings identified provide the minimum mandatory requirements and must be modified for the specific application, environmental conditions, and local/project constraints.

**1.5 GENERAL BUILDING REQUIREMENTS.** Comply with approved standards for typical design disciplines and building systems, as well as for accessibility, antiterrorism, security, high performance and sustainability requirements, and safety. This publication is one that covers minimum standards, planning, preliminary design, and detailed design for security and antiterrorism. These publications are designed to be used by a diverse audience to facilitate development of projects throughout the design cycle.

**1.5.1 APPLICATION.** The application of this publication is illustrated in Figure 1. This publication is intended to be the starting point for any project that is likely to have security or antiterrorism requirements.

**1.5.2 REQUIREMENTS DETERMINATION.** This publication includes a process for defining the design criteria for a protective system that protects important assets associated with a permanent facility or one in an expeditionary environment. The design criteria will consist of the assets to be protected, the threats to those assets, the degree to which those assets will be protected against the threat, and any constraints that might be imposed on a design. The design criteria may be limited to that defined in minimum standards or it may go beyond those requirements. Establishing the design criteria for security and antiterrorism is not something that can be done effectively by any one person. It requires a team of people to ensure that the varied interests relating to a project are considered appropriately. The specific membership of a planning team will be based on local considerations, but in general, the following functions should be represented - facility user, antiterrorism, intelligence, operations, security, logistics, engineering, and resource management. Based on local considerations, there may be others who should be consulted for input into the design criteria. They might include fire marshals, communications people, environmental people, and historic preservation officers.

**1.5.3 INTEGRATION WITH OTHER REQUIREMENTS.** Security and antiterrorism requirements will never be the only requirements associated with a project. Even

where a project is specifically for security and antiterrorism upgrades, there will still be other requirements that must be considered. There will be times where one criterion is more stringent than another, in which case the more stringent one must be applied. In some cases, criteria may conflict. In those cases, those conflicts must be resolved, which may require compromise or adjustment to one or the other criteria. Many security regulations specify protective measures, policies, and operations related to security.

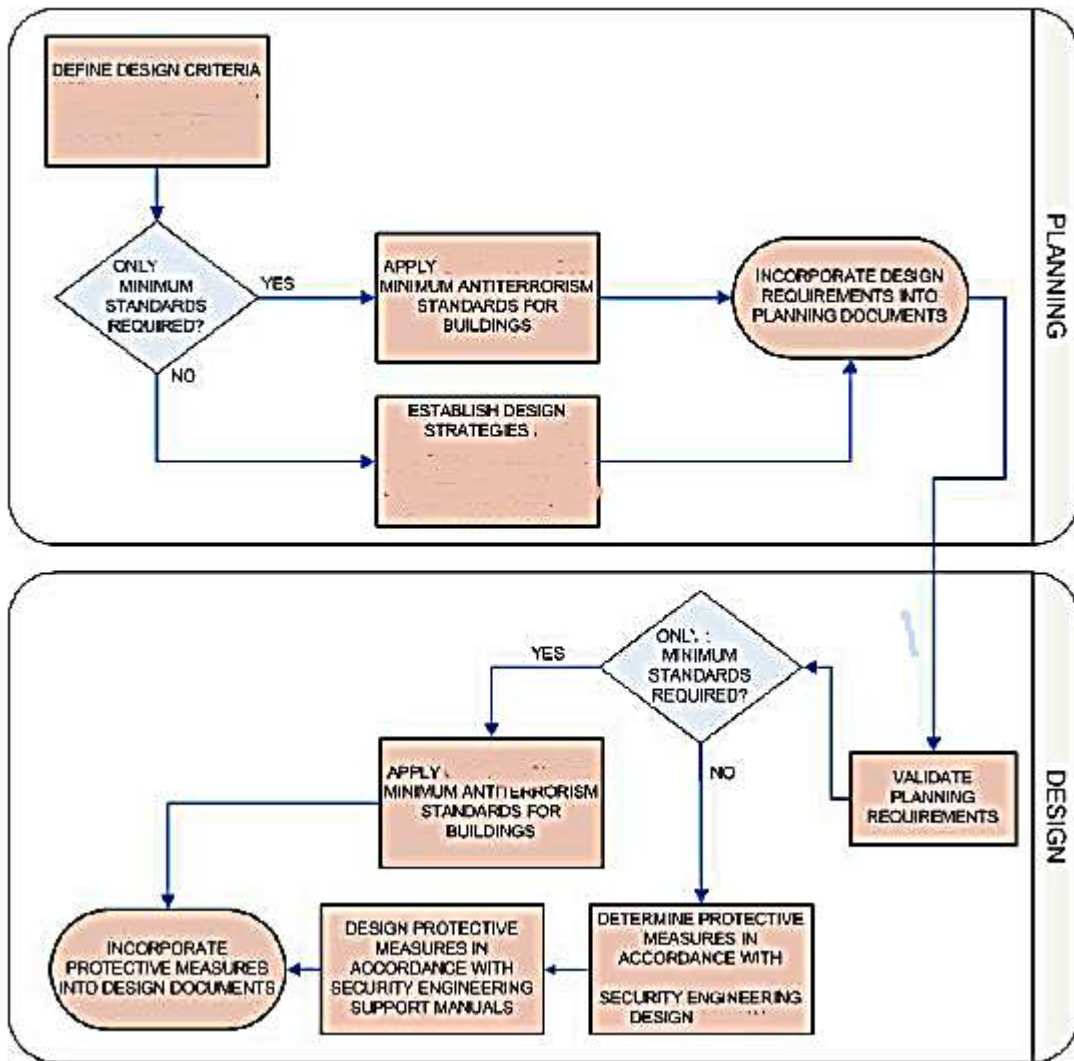

Figure 1

**1.6 VULNERABILITY AND RISK ASSESSMENT.** A vulnerability and risk assessment must be conducted prior to beginning any security project. Upon identifying facility or asset vulnerabilities to threats, physical security measures such as security fences, gates, and Electronic Security Systems (ESS) may be deployed to reduce vulnerabilities. In summary, this discussion assumes the pre-design phases, including the risk analysis, are complete prior to beginning design. The engineering risk analysis conducted must be consistent with the terrorism risk analysis conducted by the installation security staff.

**1.7 PHYSICAL SECURITY.** That part of security concerned with physical measures designed to safeguard personnel; to prevent or delay unauthorized access to equipment, installations, material, and documents; and to safeguard them against espionage, sabotage, damage, and theft.

**1.7.1 PHYSICAL SECURITY SYSTEM.** A system comprised of people, equipment, and operational procedures that control access to critical facilities or assets. Fences are but one of many elements that comprise the equipment component of a physical security system. Figure 2 diagrams some of the additional components of a physical security system. From Figure 2, fencing is considered part of the delay function of the overall Physical Security System. However, standard chain-link fencing provides approximately 7- 15 seconds of delay.

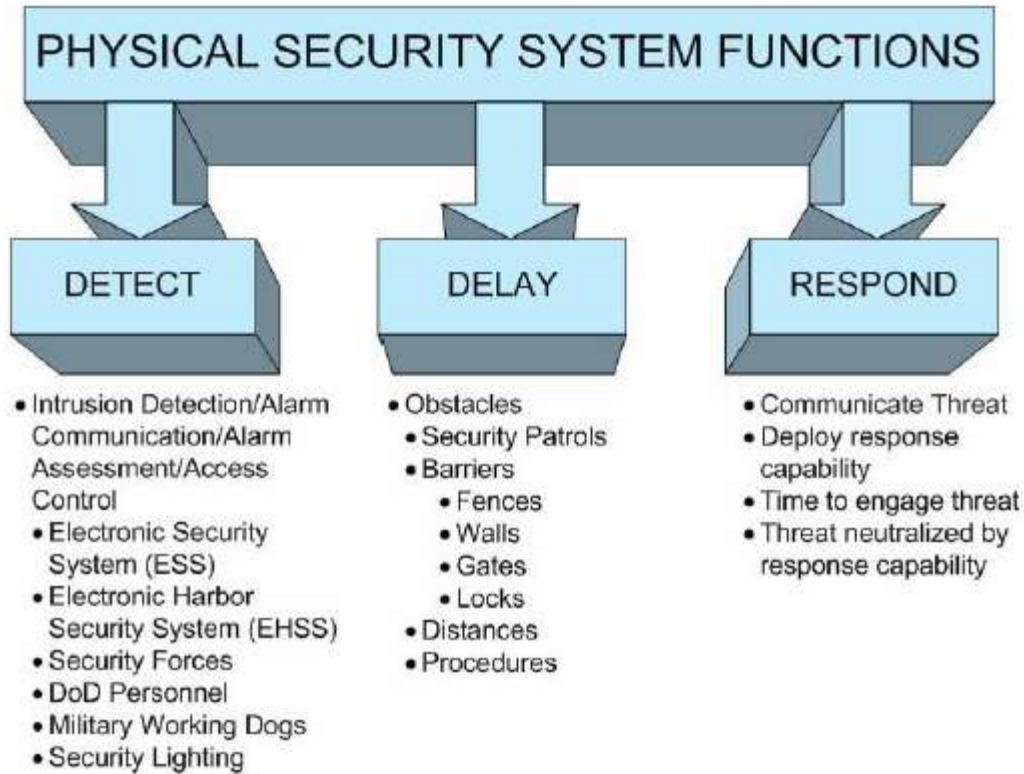

Figure 2

Diagram of physical security system functions

**1.9 EMERGENCY ACCESS.** Locate security fence as to not impede emergency vehicle or emergency personnel access to fire hydrants or other fire protection features. Coordinate with installation fire department regarding security fence location as it applies to fire hydrants and other fire protection features.

**1.10 CORROSION PREVENTION CONTROL.** Design strategies for installation security structures and equipment must consider corrosion prevention and control (CPC) preservation techniques for long term maintainability throughout their life cycle. Trade-off decisions involving cost, useful service life, and effectiveness must address corrosion prevention and mitigation.

**1.10.1 MATERIAL SELECTION AND COATINGS.** Local environments must be considered during the selection of material for the fencing components as well as the

required coatings to provide protection against corrosion. Color polymer and other coatings on fencing fabric, fittings, framework, and gates must be applied to enhance visibility and provide greater corrosion resistance, especially in corrosive or salt laden environment. Coating on any fasteners or ties must be electrolytically compatible with fencing fabric to inhibit corrosion. All security fence fittings must be electrolytically compatible with all fence components. Regarding drainage openings (ditches, culverts, vents, metal ducts/pipes, and other opening) consideration must be given to the materials used (smaller metal pipe, metal/steel grillage) in securing such openings. One of the most important corrosion issues is the chemical reaction between dissimilar metals. When dissimilar metals are in contact with one another in the presence of an electrolyte, galvanic action occurs, resulting in the deterioration. The electrolyte may be rain water running from one surface to another, or moisture from the air containing enough acid to cause it to act as an electrolyte.



## 2. FENCING

**2.1 FUNCTION.** The physical security barrier provided by a security fence provides one or more of the following functions:

- Gives notice of legal boundary of the outermost limits of the protected area.
- Assists in controlling and screening authorized entries into secured/protected areas by channeling vehicles and personnel to access control points.
- Supports surveillance, detection, assessment, and other security functions by providing a platform for installing intrusion detection equipment.
- Deters casual intruders from penetrating a secured/protected area by presenting a barrier that requires an overt action to enter.
- Causes a delay to obtain access to a installation/facility, thereby increasing the probability of detection.

**2.2 CHAIN LINK FENCING.** Chain link fence is a fencing material made from wire helically wound and interwoven in such a manner as to provide a continuous mesh without knots or ties. See Figure 3 below for standard chain link fence details identifying all of the components. Refer to the Chain Link Manufacturers Institute's Security Fencing Recommendations (CLF-SFR0111) and Product Manual (CLF0PM0610) for additional information.

**2.2.1 CHAIN LINK FENCING FABRIC.** Fencing fabric must be minimum 9-gage wire mesh and mesh openings must be not be greater than 2-inches (51 mm) per side. Fence fabric material will be galvanized steel, PVC coated steel fabric (use PVC coated if located in corrosive environment or where aesthetics are of prime importance), or aluminum coated steel fabric (use aluminum coated if located in corrosive environment).

**2.2.1.1 ADDITIONAL FENCING FABRIC REQUIREMENTS.** The fencing fabric must be extended to within 2 inches (51 mm) of firm ground and anchored, if required by

service requirements, using horizontal bottom rails, tension wires, concrete curbs, sills, sheet piling, piping, or other inexpensive materials. For additional security burying the fabric 12 inches (305 mm) may also be considered; however, corrosion of the buried fabric must be monitored. This anchoring will prevent the fencing fabric from being able to be lifted by hand more than 5 inches (125 mm) in height. Horizontal bottom rails, concrete curbs, or sills can assist in mitigating an intruder from lifting the fence fabric beyond the requirement above. Mesh openings in chain link fencing are intended to not be covered, blocked, or laced with material which would prevent a clear view of personnel, vehicles, or material in outer clear zones. Locate all posts, rails, bracing and tension wires on the secure/protected side, i.e. inner side, of the fencing fabric. Select the framework components and material from ASTM F626, ASTM F1043, and ASTM F1083.

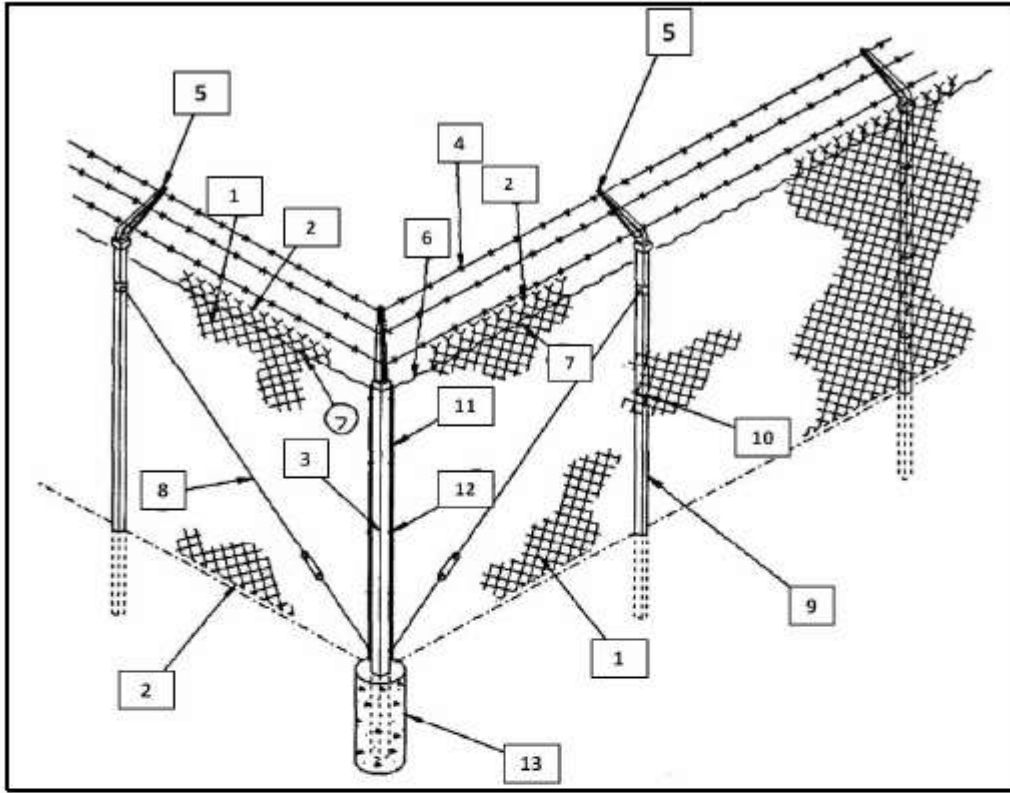

1	Fabric
2	Selvage
3	Corner Post
4	Barbed Wire/Barbed Tape
5	Outrigger/Barbed Wire Arm
6	Tension Wire (Top and Bottom)
7	Hog Ring
8	Truss Rod
9	Line Post
10	Tie Wire
11	Tension Bar
12	Tension Clip
13	Concrete Footing

Figure 3  
General chain-link fence components

**2.2.1.2 TOP AND BOTTOM SELVAGES.** Selvage is the edge finish on woven chain link fabric joining pairs of pickets. The selvage may be knuckled or twisted depending on application. Knuckled selvage is defined as the type of selvage obtained by interlocking adjacent pairs of wire ends and bending the wire back into a loop. Twisted is obtained by twisting adjacent pairs of wire ends together in a close helix of 1 1/2 machine turns, which is equivalent to three full twists. See Figure 4 for selvage examples. Twisted selvage must be provided on the top of the fence fabric to deter climbing. Twisted selvage must be provided at the bottom of the fence fabric to deter borrowing unless the fence has a bottom rail, is buried, or encased in concrete. In these applications the selvage may be knuckled.

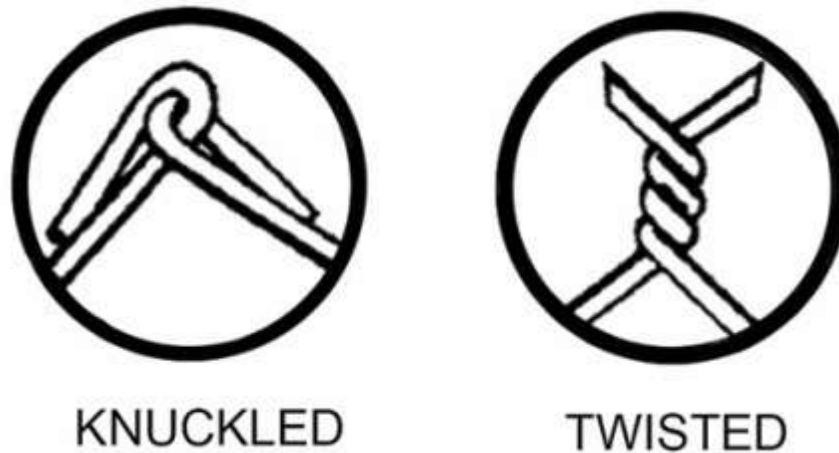

Figure 4  
Selvage

**2.2.1.3 FENCE POSTS.** Fencing fabric must be mounted on steel posts that are set in concrete with additional bracing at corners and gate openings, as necessary. If steel posts are not available, reinforced concrete posts will be used. Posts, bracing, and all other structural members must be placed on the secure-side of the fencing fabric. Posts must be vertical within plus or minus 2 degrees in each direction. Determine the embedment depth of the fence posts and associated footings considering wind load,

local soil conditions, and the potential for wind and water erosion. Posts for security fencing must be embedded and encased in concrete according to the design details in Appendix C.

**2.2.1.4 FENCE BRACING.** Steel truss rods used for bracing must have a minimum nominal diameter of 5/16 inch (8 mm) and provided with turnbuckles for tensioning. Provide bracing for each gate, terminal and end post. Install truss rods diagonally from near ground level of the gate, terminal or end post to within 6 inches (152 mm) from the top of the fabric at the adjacent line post. Fencing fabric can be securely fastened to tension wires on the top and bottom with 9 gage (3.76 mm) galvanized tie wires incorporating at least three full twists, 9 gage (3.76 mm) round wire galvanized hog rings, or in a manner that provides a tensile strength equal to or greater than the strength of the fencing fabric. Consider securing all fastening and hinge hardware by peening or welding to prevent disassembly of fencing and gate components where warranted by the required level of protection. See Appendix C for design details of chain link fencing posts, rails, braces, and tension wires.

**2.3 ORNAMENTAL FENCES.** Ornamental (also known as tubular) fencing provides a greater resistance to climbing as well as providing aesthetic qualities in comparison to chain link fencing. Ornamental fencing systems are constructed of either steel or aluminum components. Install ornamental fence pickets plumb and provide a minimum of 2 inches (51 mm) or maximum of 6 inches (152 mm) between the fence and the ground. See ASTM F2408 for additional guidance for ornamental fence systems. See Appendix C for design details of ornamental fence.

**2.4 WELDED WIRE MESH FABRIC FENCING.** Welded wire mesh fabric fencing material is composed of a series of longitudinal and transverse steel wires arranged substantially at right angles to each other, and welded together. In comparison to chain link fencing has a greater deterrence to intrusion by climbing and cutting. Welded wire mesh fabric fence openings are relatively small to prevent toe or finger hold. Although the mesh sizes are small, visibility through the fence may be higher

than chain link fencing even at right angles near parallel to the fence line. See ASTM F2453/F2453M for material requirements. Maximum vertical/horizontal opening dimension must be 2 inches (51 mm). Minimum thickness – 9 gage (3.76 mm). Welded wire mesh fabric fencing construction costs in non-urban environments may be approximately one half of ornamental security grade fencing. See Figure 5 for an example of a welded wire mesh fence.

**2.4.1 FENCE COMPONENTS, FITTINGS, AND ACCESSORIES.** Provide welded wire mesh posts in accordance with ASTM F626, ASTM F1083, ASTM F1043, or ASTM A500/A500M. Posts and rails must be designed to resist specified loading and be spaced per manufacturer's guidance. Connect fencing fabric with a minimum of 9 gage (3.76 mm) tie wires or other connection per manufacturer providing equal or greater capacity and resistance to tampering. If using welded wire mesh fence panels, attach to line and terminal posts and gate frames with post brackets.



Figure 5

Welded wire mesh fence

**2.5 EXPANDED METAL FENCING.** Similar to welded wire mesh fabric fencing, expanded metal fencing is ideal for medium and high security applications. The diamond shaped mesh's small openings and wide strands deter climbing, cutting, and tunneling. Panels are constructed of steel sheets, simultaneously slit, and stretched into a rigid, open mesh design making continuous sheets that prohibit unraveling at the strands. Maximum vertical/horizontal opening dimension must be 2 inches (51 mm). Minimum strand width must be 0.150 inches (9 gage) (3.81 mm). In lieu of installing a fence topping, an expanded metal fabric cap sheet can be installed at a 45-degree angle extending outside of the secured perimeter and terminating with a turned up vertical section. If additional protection measures are required, barbed tape can be applied to the back of the vertical portion of the cap sheet. See ASTM F2548 and



ASTM F2780 for design, construction, and application of expanded metal fencing systems. Available fence patterns can provide the architectural aesthetics of ornamental fencing. See Figure5 for an example of an expanded metal fence.

**2.5.1 RETROFIT EXISTING FENCE.** Expanded metal fencing can be applied as a retrofit to existing chain link fencing and gates to provide additional protection, strength, and durability. Expanded metal fencing should be installed directly to the existing fence utilizing the installed chain link fence fabric and framework.

**2.5.2 FENCE COMPONENTS, FITTINGS, AND ACCESSORIES.** Line and terminal posts must be hot-dip galvanized in accordance with ASTM F626, ASTM F1043, and ASTM F1083. The manufacturer's recommendation must be considered when spacing line posts. Top, middle, and bottom rails must be hot-dip galvanized. Rails can be fastened to posts using clamps. Standard weight piping must be used for the posts and rails of expanded metal fencing. Fittings such as line rail clamps, post caps, tension bands, and panel clamps must be galvanized, heavy pressed steel or malleable iron.





Figure 6  
Expanded metal fence

**2.6 FARM STYLE FENCES.** Farm style fences are constructed of wood and/or metal posts and wire. Pressure treat all wood posts and metal posts must be zinc coated and conform to ASTM A702. Steel post conforming to ASTM F1043 must be used in conjunction with T-section or U-section line post. The gates are constructed of 1 5/8 inch (41.3 mm) minimum diameter tubular steel, and secured with a chain and padlock.

**2.7 EXPEDITIONARY PERIMETER FENCING.** Not covered in this publication.

**2.8 FENCE FABRIC HEIGHT.** Unless otherwise directed all security and perimeter fencing must have a minimum fence fabric height of 7 feet (2.13m), excluding the top guard. Fence height including outriggers must be a minimum of 8 feet (2.44m).

**2.9 TOP GUARDS.** When required, install outriggers (support arms) at 45-degree angles in a single arm (towards the threat side) or “Y”/”V” configuration, constructed of a single or double outrigger consisting of 18-inch (457 mm) arm(s), each having three strands of barbed wire at regular intervals along the top of the fence. The outriggers must provide a minimum of an additional 12 inches (305 mm) to the fence height. The

top guard fencing adjoining gates may range from a vertical height of 18 inches (457 mm) to the normal 45 degree outward protection, but for a limited distance along the fence line to adequately open the gates. Outriggers must be permanently affixed to the fence posts with screws or by spot welding. Screws used to affix outriggers to posts must be made tamper-proof either by design, peening, or welding.

**2.9.1 OUTRIGGER/BARBED WIRE ARM MATERIAL SPECIFICATIONS.** Top guards must be constructed of the same material as the other fencing components in accordance to ASTM F626.

**2.9.2 BARBED WIRE AND BARBED TAPE CONCERTINA.** Barbed wire is a fabricated wire product consisting of two line wires twisted to form a two-wire strand, into which 2–point or 4–point barbs are tightly wrapped and locked into place at specific intervals. Barbed tape concertina is a strip of metal, machined to produce clusters of sharp points. Provide three strands of barbed wire, equally spaced, on outrigger/support arms where barbed tape/concertina is mounted.

**2.9.2.1 BARBED WIRE.** Fences requiring barbed wire must use a minimum of 3 strands of barbed wire equally spaced. Additional strands may be added as required. Barbed wire must consist of two 12.5-gage /0.099-inch (2.5 mm) (+0.005-inch (.127 mm)) twisted line wires with 15-gage /0.080-inch (2 mm)(+0.005-inch (.127 mm)) round barbs. Barbed wire must be zinc-coated steel, aluminum coated steel, aluminum alloy, or PVC over zinc-coated steel as specified. All barbs must consist of four points and spacing of barbs must be at 5-inch (127 mm) (+1-inch (25.4 mm)) centers.

**2.9.2.1.1 BARBED WIRE MATERIAL SPECIFICATIONS.** Barbed wire must be in accordance to ASTM A121 and ASTM F1665.

**2.9.2.2 BARBED TAPE/CONCERTINA.** Barbed-tape concertina is a commercially manufactured wire coil constructed of high-strength-steel barbed wire that is clipped together at intervals to form a single coil or double coil. The single coil must be a

minimum of 2 feet (610 mm) in diameter and extend at least 50 feet (15.2 m) without permanent distortion. Double coil must be 24/30 inch (610 mm/762 mm) and extend at least 50 feet (15.2 m) without permanent distortion. Barbed tape concertina may be added to the top and, in some cases, to the bottom to increase the level of protection. Barbed tape concertina must be secured at a minimum interval of 18 inches (457 mm) along the fence fabric to the top barbed wire strand and a maximum gap of 2 inches (51 mm) must be maintained between the bottom barbed wire and the top of the chain-link fabric. After use, barbed tape concertina may be recoiled and reused without distortion. For additional protection, barbed tape concertina may be installed between the “Y” configuration of the outriggers.

**2.9.2.2.1 BARBED TAPE/CONCERTINA MATERIAL SPECIFICATIONS.** Barbed tape concertina must be in accordance to ASTM F1911 and ASTM F1910.

### **2.9.2.3 SPECIFIC BARB REQUIREMENTS**

**2.9.2.3.1 FARM STYLE FENCE.** Any barbs used with farm fencing must be a minimum of 15.5 gage wire. Barbed clusters must have a minimum width of 1.2 inches (30.7 mm). The distance between these strands is intended not to exceed 6 inches (152 mm) and at least one wire must be interlaced vertically and midway between posts. The ends of the barbed wire strands may be staggered or fastened together, and the base wire may be picketed to the ground.

**2.9.2.3.2 BARB WIRE FENCING.** 3, 4, or 5-strand barbed wire fencing, 4 feet (1.2 m) high, should be used for extensions of flight-line area barriers, perimeter boundary for isolated portions of installations, livestock barrier, and area boundary for on-base bulk material storage areas. Barbed wire fastened on wooden posts may use a minimum of 1.5 inch (38 mm) staples made from the same metal as the wire for fastening.

**2.9.2.3.3 TEMPORARY USAGE.** When used for temporary purposes (not used as fence topper), concertina wire should be used in multiple stacked coils. Stacked

concertina wire on perimeter barriers may be laid between poles with one roll on top of another or in a pyramid arrangement (minimum of 3 rolls). Concertina blades must have a minimum length of 1.2 inches (30.7 mm). Barbed tape concertina as an expedient measure for short-term use, pending the erection of permanent fencing, can be non-reinforced. Reinforce all barbed tape concertina used for permanent security applications.

**2.10 GROUNDING.** Grounding and bonding of the perimeter systems must be in accordance with the National Electric Safety Code (NESC) - IEEE C2. Fences that are required to be grounded by NESC must be designed to limit touch, step, and transferred voltages in accordance with industry practices. IEEE Std 80™-2000 - IEEE Guide for Safety in AC Substation Grounding is one source that may be utilized to provide guidance in meeting these requirements. The grounding connections must be made either to the grounding system of the enclosed equipment or to a separate ground.

- Fences must be grounded at each side of a gate or other opening.
- Gates must be bonded to the grounding conductor, jumper, or fence.
- A buried bonding jumper must be used to bond across a gate or other opening in the fence, unless a nonconducting fence section is used.
- If barbed wire strands are used above the fence fabric, the barbed wire strands must be bonded to the grounding conductor, jumper, or fence.
- When fence posts are of conducting material, the grounding conductor must be connected to the fence post or posts, as required, with suitable connecting means
- When fence posts are of nonconducting material, suitable bonding connection must be made to the fence mesh strands and the barbed wire strands at each grounding conductor point.

**2.11 REINFORCEMENT FOR FENCING.** For fabric type fences install fence reinforcement between fence fabric and fence post. For both fabric type and

ornamental fences reinforcement must be installed on exterior side of fence post. If located in a corrosive environment, coated or sheathed cable may be used; however, the sheathing must be removed at the connections.

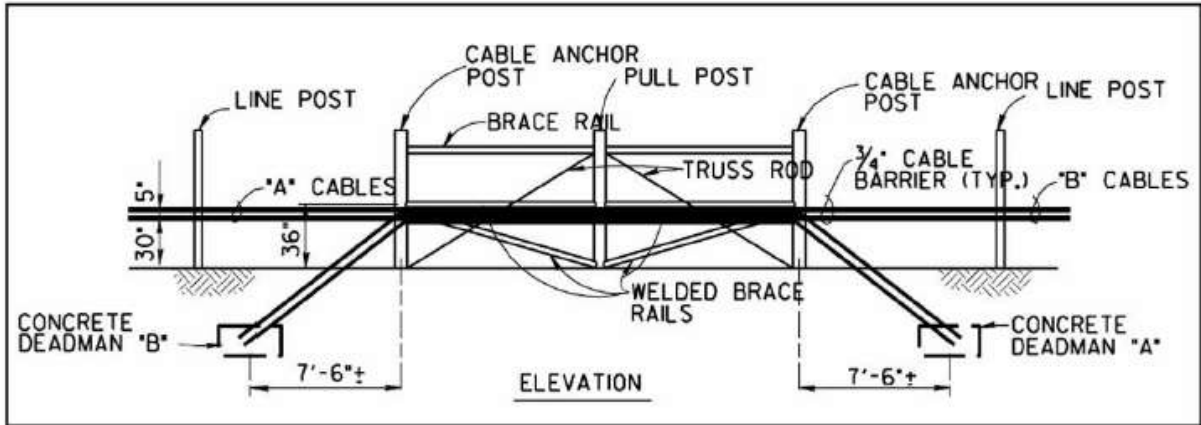

Figure 7

Steel cable-reinforced chain link fence

**2.11.1 DEADMAN ANCHOR.** Reinforcing cables must be terminated to concrete deadman anchors. Anchors are to be placed at intervals of 200 feet (61 m) on the secure/protected side of the perimeter fencing. Offset deadman anchors from fence at the minimum distance required to avoid interference with post and to allow maintenance access to the turnbuckles, clamps, and other accessories. The anchoring system: deadman dimensions or other anchoring systems and burial depth, eyebolt embedment depth, etc. must be designed for local soil conditions and the anticipated impact force established by the threat parameters.

**2.11.1.1 CABLE CONNECTION.** Eyebolts embedded in the concrete deadman anchors may have either a welded “T” or “L” end. The eyebolt can either be in-line with the attached cable or flush against the deadman surface. When used, eyebolts should be welded and galvanized to the anchor rods. The top side of the deadman can either be placed flush with or below the ground surface with the eye of the eyebolt above

ground. Threaded rods may also be used as an alternative to the eye bolt when securing the cables to the deadman anchor. When using threaded rods, the threaded rod and wire rope connection must be visible above ground like the eyebolt previously described. Figure 8 shows the deadman position using a cable clamp and turnbuckle to secure the cable rather than a swaged on clamp. This turnbuckle adds the advantage of being able to adjust the tension of the cable.

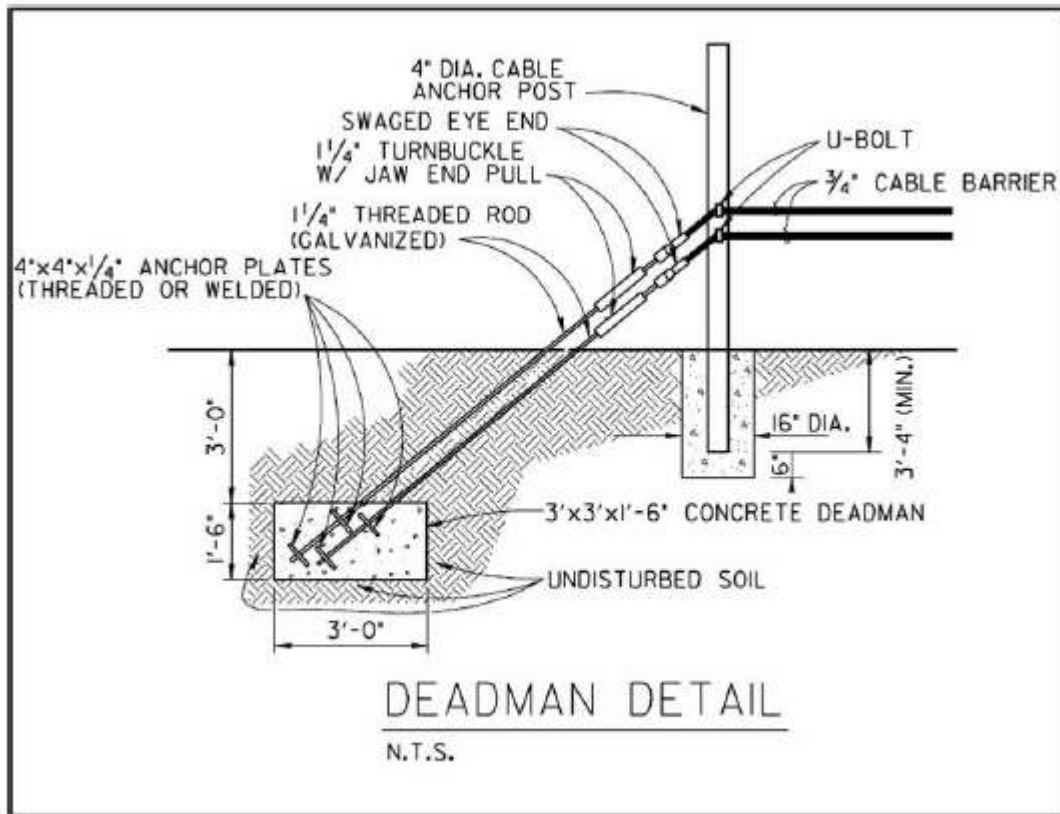

Figure 8

Deadman anchor detail

## 2.12 SPECIAL SECURITY FEATURES

**2.12.1 CLEAR ZONES.** Clear zones are areas established around the fence to provide and unobstructed view to enhance detection and assessment around fences. When required, dimensions of clear zones vary depending on asset being protected

and level of protection. For example, outer clear zones may be 30 feet (9 m) wide and inner clear zones may be 20 feet (6 m) wide. Consult with Service policies for assets being protected to determine if clear zones are required and what dimensions are required.

**2.12.2 DOUBLE FENCE LINES.** Assets that require Electronic Security Systems (ESS) for perimeter security may require a double fence line. Perimeter ESS and double fence lines typically associated with assets that require a high level of protection for the force or covert entry tactic. This system is intended to increase the probability of detection, decrease nuisance alarms, and prevent access to ESS. The typical configuration is outer clear zone, outer fence, isolation zone, inner fence, and inner clear zone. See Figure 9 a/b below.

**2.12.2.1 OUTER FENCE LINE.** Outer fence line acts to reduce the Nuisance Alarm Rate (NAR) by keeping animals, people, vehicles, and windblown debris out of the isolation zone. No sensors should be placed on the outer fence of a double fence line system. In some instances the outer fence line may define a protected or restricted area boundary. In the case where the outer fence line defines a protected or restricted area boundary, the outer fence must meet the minimum requirements as set forth in this publication.

**2.12.2.2 ISOLATION ZONE.** The isolation zone is the area between the inner and outer fence lines sometimes referred to as the detection zone and must meet clear zone requirements indicated above. The area must be free of all vegetation and above ground obstructions except for the ESS and its supporting infrastructure. The isolation zone is typically light colored gravel or crushed stone bed sloped to prevent standing water. This reduces maintenance, increases probability of detection, and enhances the assessment capability within the fence lines.

**2.12.2.3 INNER FENCE LINE.** The Inner fence line provides the inner boundary for the isolation zone and defines the protected or restricted area boundary. It may be



used for mounting of fence line detection systems such as taut wire, Time Domain Reflectometry (TDR), or fiber-optic strain-sensitive cable systems, refer to appropriate technical guidance for sensor types and applications. When used as a foundation for fence line detection systems, the fence meet the following minimum requirements.

**2.12.2.3.1 INNER FENCE FABRIC.** Fence fabric material must be in accordance with ASTM A491 and must comply with minimum requirements set forth in this publication.

**2.12.2.3.2 INNER FENCE COMPONENTS, FITTINGS, AND ACCESSORIES.** Select the framework components and material from ASTM F626, ASTM F1043, ASTM F1083, and ASTM F1712 in addition to the following:

- End, corner, and pull posts will be concrete filled.
- Gateposts must be minimum of 4-inch (102 mm) outside diameter (O.D.) and be sized according to Table 1.
- Three (3) tension bands must be used. Top tension wire must be 7.5-inches (191 mm) below top of fabric with the other two (2) bands located approximately 31(787) and 56.5 (1435) inches (mm) down respectively from the top of fence fabric.

PIPE	SIZE
Bottom or Brace Rails	1 5/8 in (41mm)
Line Posts	2 1/2 in (63.5mm)
Corner, end and pull posts)	4 in (102mm)
Single Gate Posts – equal or less than 12ft (3.7m) Width	4 in (102mm)
Double Gate Posts – equal or less than 24ft (7.3m) Width	4 in (102mm)
Single Gate Posts – greater than 12ft (3.7m and less than 18ft (5.5m) Width	6 5/8 in (168 mm)
Double Gate Posts – greater than 24ft (7.3m) and less than 36ft (11m) Width	6 5/8 in (168 mm)
Single Gate Posts – over 18ft (5.5m) Width	8 5/8 in (219 mm)
Double Gate Posts – over 36ft (11m) Width	8 5/8 in (219 mm)

Table 1



### Fence type components

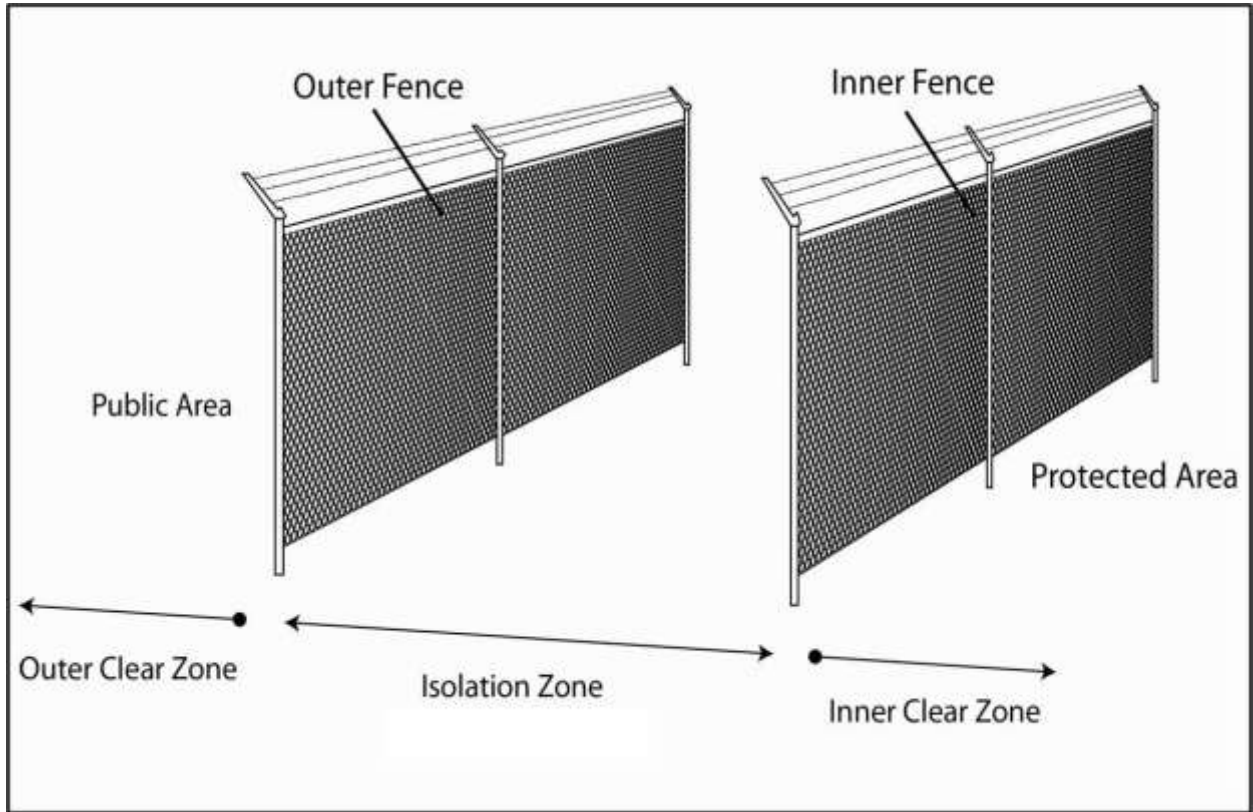

Figure 9a  
Double fence line



Figure 9b  
Double fence line

**2.12.3 FENCE LINE ELECTRONIC SECURITY SYSTEMS.** Electronic Security Systems (ESS) may be used to increase the probability of detection and the assessment of intruders attempting to enter restricted areas. ESS includes Intrusion Detection Systems (IDS), Access Control Systems (ACS), and Closed Circuit Television (CCTV) for assessment of alarm conditions. The design of fences and gates must support the site specific design of the ESS as required.

**2.12.4 SECURITY LIGHTING.** Security lighting or protective lighting provides illumination during periods of darkness or in areas of low visibility to aid in the detection, delay, and respond functions of a physical security system. Coordinate security lighting requirements with security personnel.

**2.12.5 PATROL ROADS.** When required provide an interior, all-weather perimeter road in all areas not affected by impassable terrain features for security-patrol vehicles. Drainage ditches parallel to patrol roads should be designed to utilize shallow or low angle side slopes to prevent obscuring the observation from a 4-foot (1.2 m) high line of sight above the road surface. Where patrol roads pass through clear zones, precautions must be taken in roadway design to preclude concealment for intruders.

**2.12.6 DRAINAGE CULVERTS AND UTILITY OPENINGS.** Provide protective measures for culverts, storm drains, sewers, air intakes, exhaust tunnels, and utility openings, that have a cross-section area of 96 square inches (61,939 square mm) or greater, with the smallest dimension being more than 6 inches (152.4 mm) and:

- Pass through clear zones.
- Traverse under or through security fences.

Such openings and barrier penetrations will be protected by securely fastened grills, locked manhole covers, or equivalent means to prevent entry or provide forced entry penetration resistance equal that of the fence. Regarding material selection for securing openings/penetrations see Material Selection and Coatings.

**2.12.6.1 LARGE DIAMETER PIPES – MULTIPLE PIPES.** If drainage conditions require large diameter pipes, or if it is a more economical approach to provide security protection, drainage openings may be constructed of multiple pipes having individual diameters of 10 inches (250 mm) or less. Extend multiple pipes through the entire conduit, secured to each other and to the large opening. As an economical alternative, reduce the pipe lengths to short segments approximately 6-inches (152 mm) long. Place the short segments at the attack side of the opening and secure them to the welded bar grill. See Figure 10.

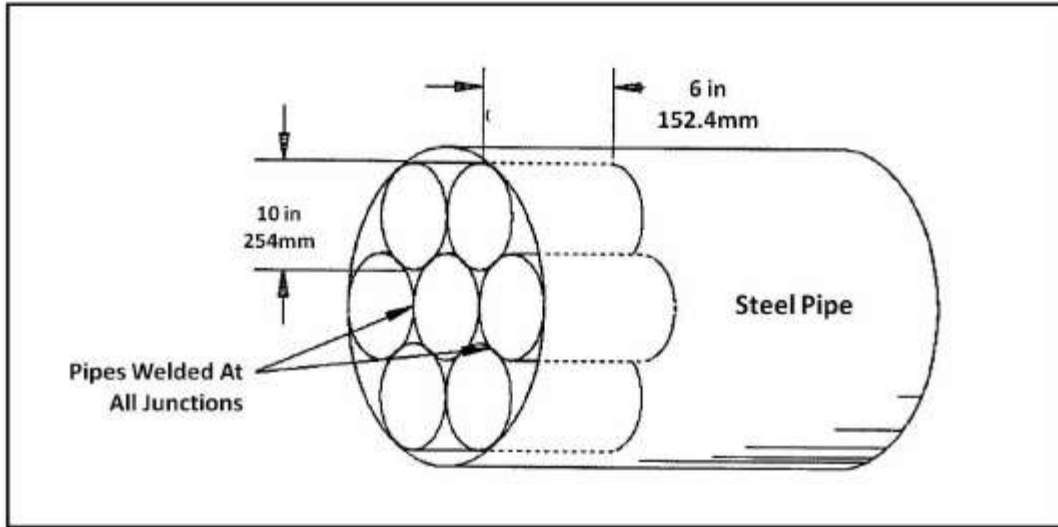

Figure 10

Large culvert with short pipes

**2.12.6.2 LARGE DIAMETER PIPES – GRILLED CONFIGURATION.** Steel pipes that pass under fences must have grills welded to the pipe as shown in Figure 11. For concrete pipes that pass under fences, the grill ends must be welded to a steel rim that fits snugly over the concrete pipe. The rim and grillwork will be fastened over the concrete pipe and bolted or pinned to the rim of the concrete pipe as shown in Figure 12. Grill ends may be embedded in a concrete headwall that encapsulates the concrete pipe. Grills must be placed on attack side of the fence. Care must be taken during design to assure that bars and grills across culverts are not susceptible to clogging. All utility openings are intended to be designed with a debris catcher to permit either rapid clearing or removal of grating for cleaning when required. Steel used for grill must be in accordance with ASTM A529 and the corrosion prevention control section of this publication.

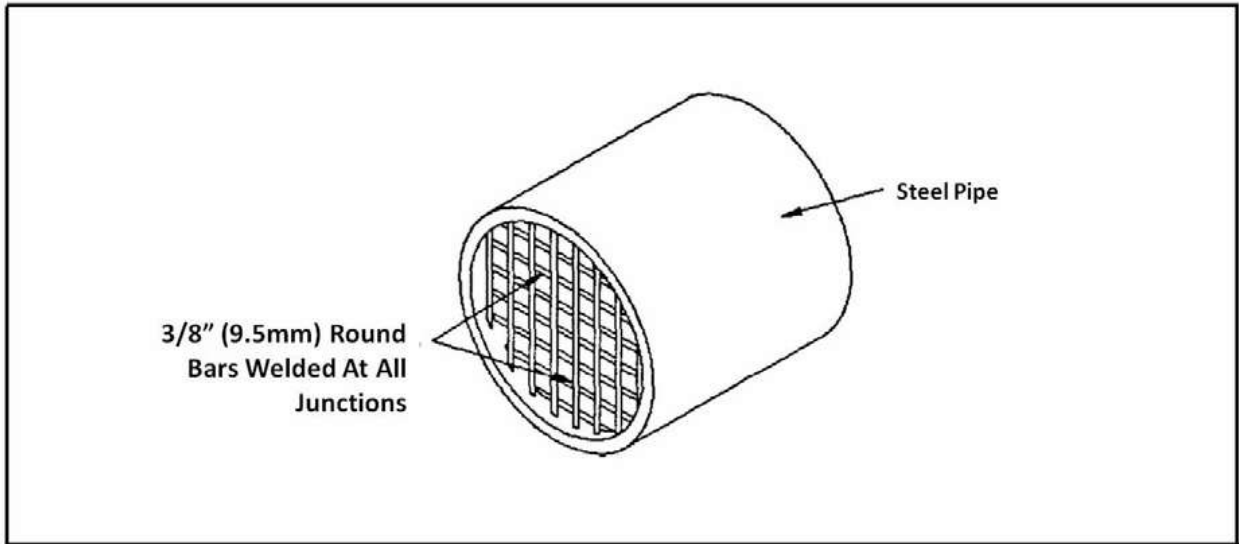

Figure 11  
Steel culvert grill

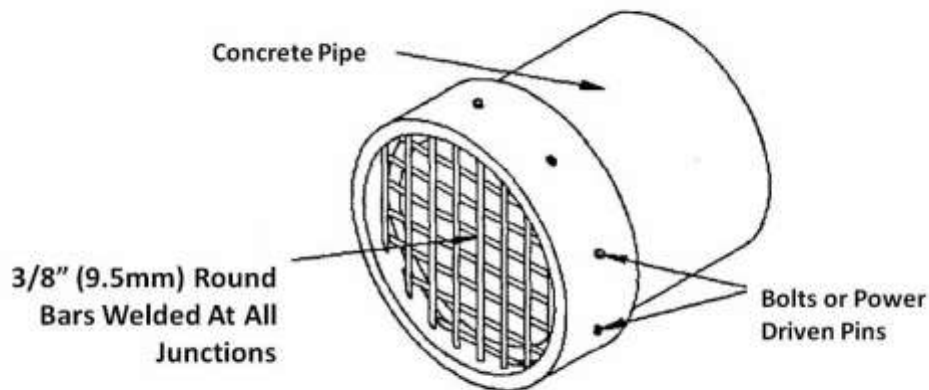

Figure 12  
Concrete culvert grill

**2.12.6.3 UTILITY OPENINGS.** Inlets for utility openings that are outside of the fence line must have a debris catcher with grating. As shown in Figure 13a/b below, inlets for utility openings that are outside of fence line must have a debris catcher (i.e. chain link fabric) with the grating on the inlet side. Caution must be taken when using debris

catchers to ensure that plugging and flooding of the area surrounding the headwall do not occur.

**2.12.6.4 ADDITIONAL CONSIDERATIONS.** In lieu of installing a grill in the utility pipe itself, provide manhole covers, 10 inches (254 mm) or more in diameter, covering a utility which passes through security perimeter fencing of a restricted access area and secure with locks and hasps or by welding them shut or by bolting them to their frame, or by using keyed bolts. Hasps, locks, and bolts must all be made of materials that resist corrosion.

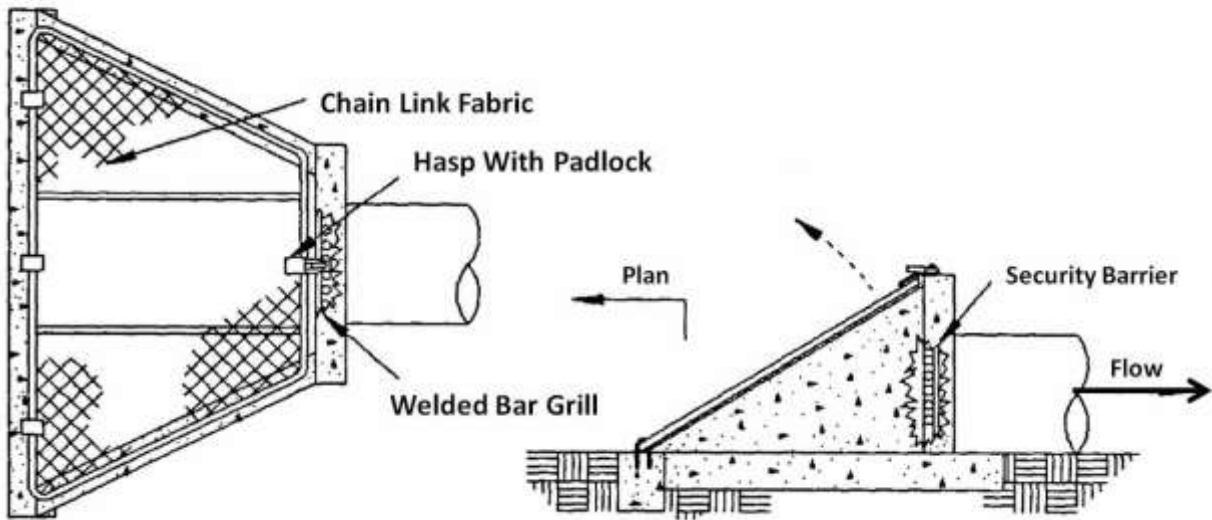

Figure 13a  
Utility openings



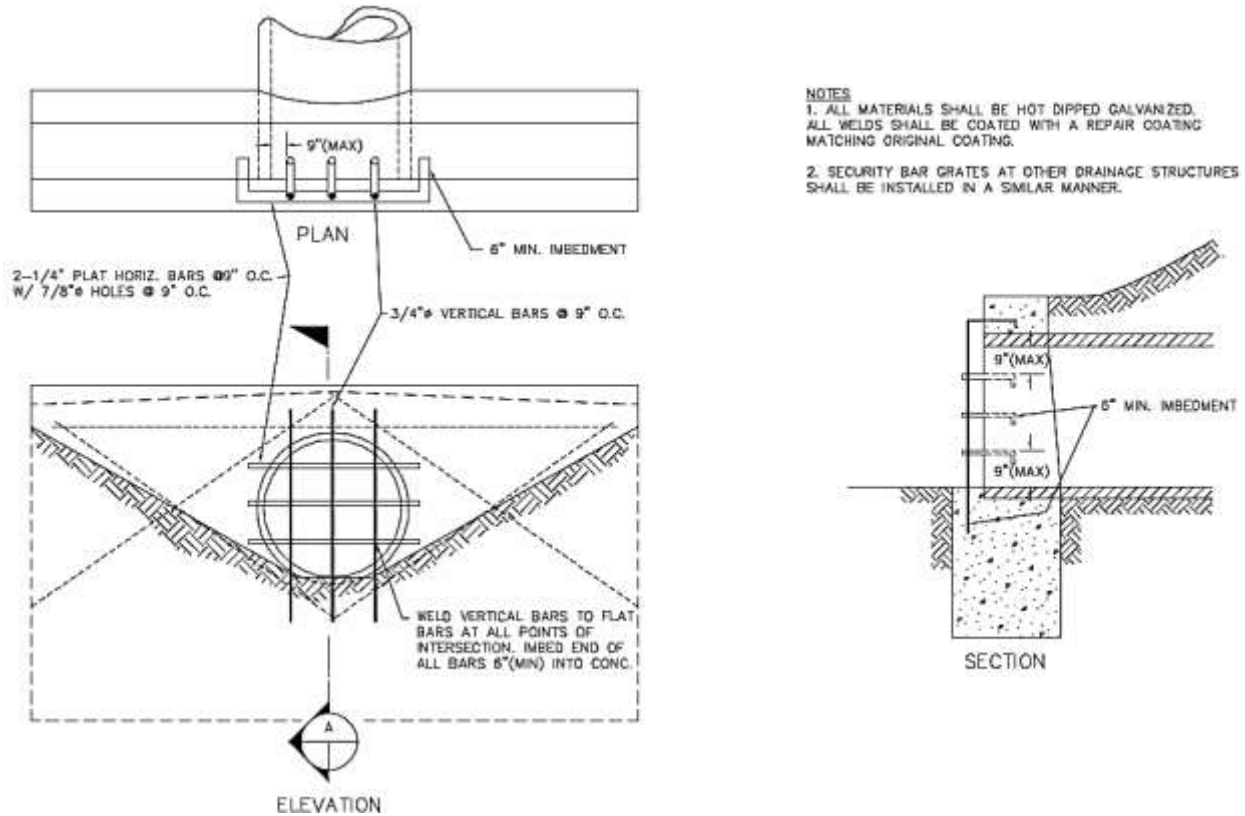

Figure 13b  
Utility openings

**2.12.7 DRAINAGE CROSSING.** Fencing passing over ditches or swales is intended to provide protection to prevent unauthorized entry. Ditches and swales that do not receive frequent water flow must provide additional fencing below, suspending from the lower rail of the main fence to the auxiliary frame and around the sides of the ditch. See Figure 19. The added fence must be attached every 2 inches (51 mm) along the intersection of the two fence sections and either attached to a series of ground stakes secured to the sides and bottom of the ditch, or embedded in a concrete sill in the ditch or swale as shown in Figures 14 and 15. Concrete curbing must be used to fill areas between fencing and ground surface. Provide a screen arrangement below fencing using vertical and/or horizontal steel bars or pipes for ditches and swales receiving frequent water flow. Provide a maximum spacing of 9 inches (229 mm) between either vertical or horizontal bars. Possible debris must be considered when designing the spacing between bars. Crossing bars must be welded at each

intersection, with bars embedded 6 inches (152 mm) into concrete and fastened to the bottom rail of the crossing fence. See Figures 16, 17, and 18. Analyze the hydraulic capacity of ditches, swales, and culverts to verify the bar grills will not decrease the channel flow capacity below the maximum expected design flow. Steel used for grill must be in accordance with ASTM A529.

**2.12.8 TUNNELING PREVENTION.** Soil under fence must provide a minimum of 15 seconds of tunneling resistance using hand tools. Tunneling prevention must be used in areas containing “soft” soils. “Very soft” and “soft” soils are those that can be extruded between fingers when squeezed and/or molded by light finger pressure. Classification of soils must be in accordance with ASTM D2487, Standard Practice for Classification of Soils for Engineering Purposes (Unified Soil Classification System), and ASTM D2488, Standard Practice for Description and Identification of Soils (Visual-Manual Procedure). Areas with a soil analysis indicating that “soft” soils are present must embed fencing in a continuous concrete curb. The recommended depth of the curb will be determined from the soil analysis and the frost depth at the facility. The frost depth for the subject areas must be considered to assure that heaving of posts and curb cannot occur during the winter. If the soil analysis does not indicate tunneling may occur quickly, continuous concrete curbing may still be considered as an added protective measure. Nuclear sites with very sandy terrain are directed to have a soils engineering analysis to determine the recommended depth of the concrete curb. Restricted access facilities with a risk of tunneling may provide IDS for tunneling protection. Welded wire mesh fence systems may incorporate additional fence panels for burial on the secure-side of the perimeter and tie-wired to the vertical panels to deter tunneling.



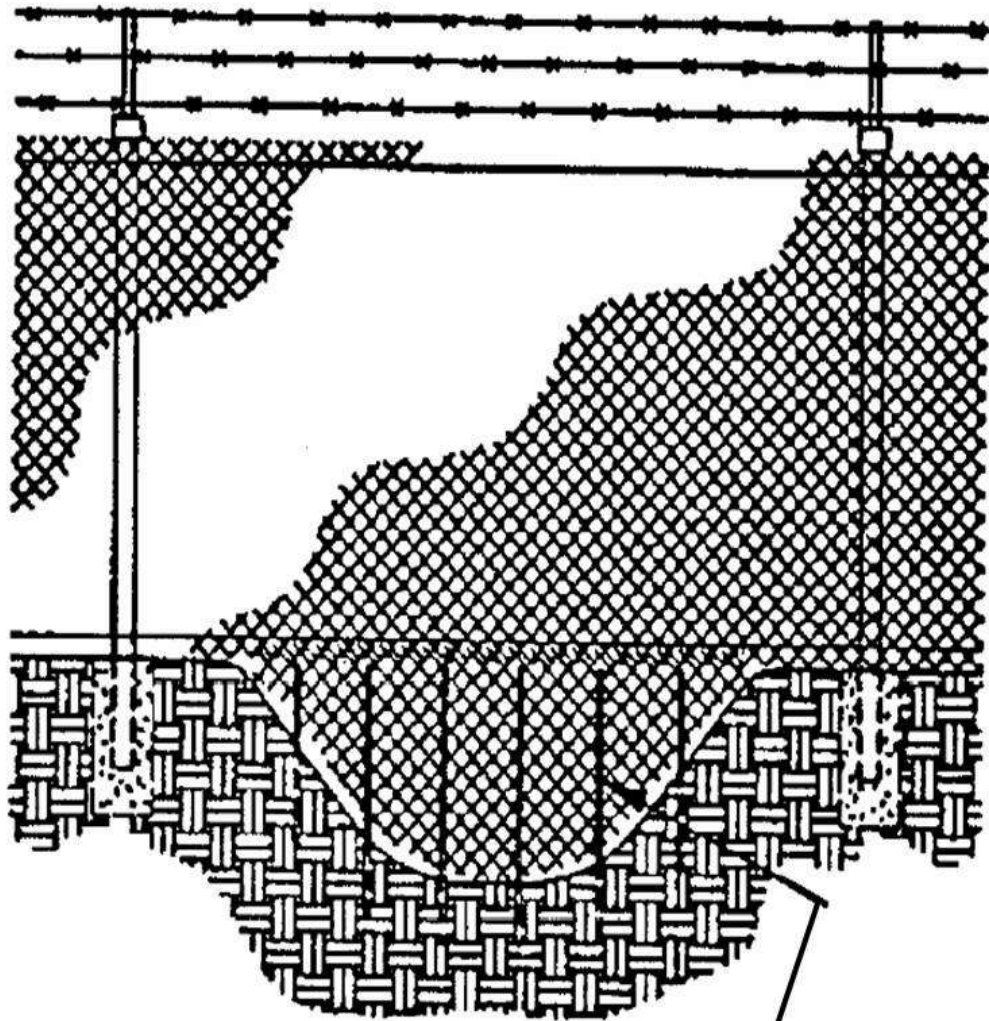

**Fence Material Tied To  
Stakes Embedded in  
Earthen Ditch**

Figure 14

Swale crossing with ground stakes

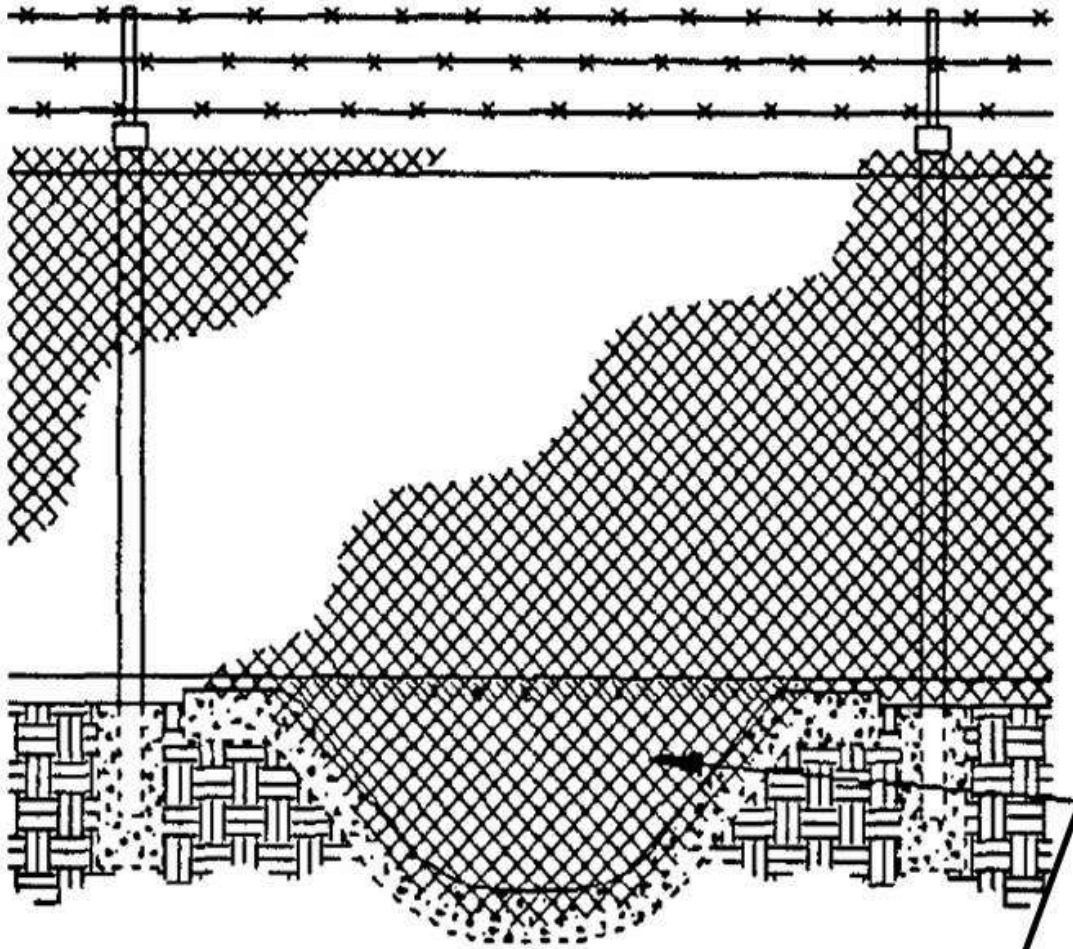

## Fence Material Embedded in Concrete Ditch and Tied To Fence

Figure 15

Swale crossing embedded in concrete



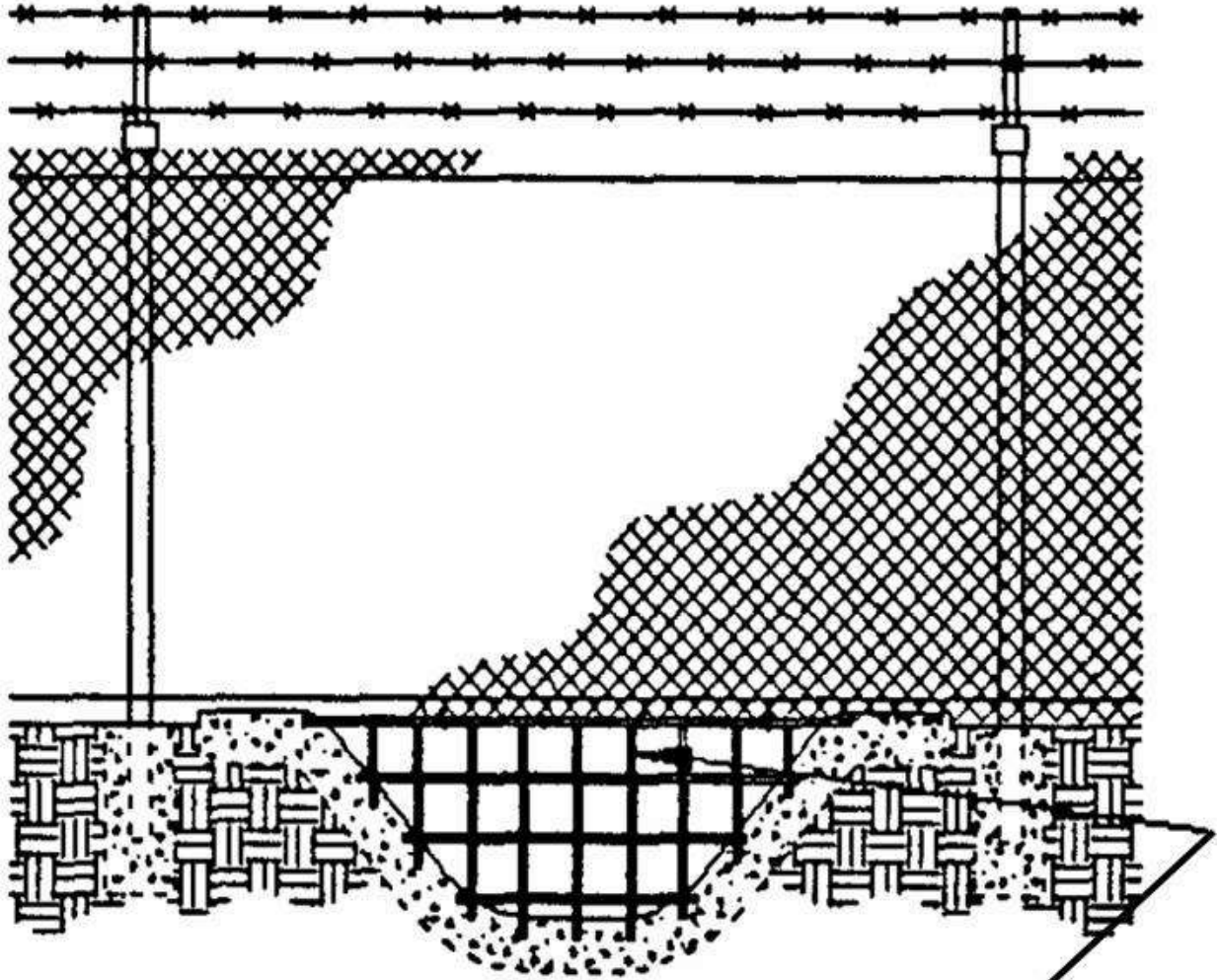

**3/8" (9.5mm) Round  
Bars Welded At All  
Junctions And  
Embedded in Concrete**

Figure 16

Bar grill embedded in concrete

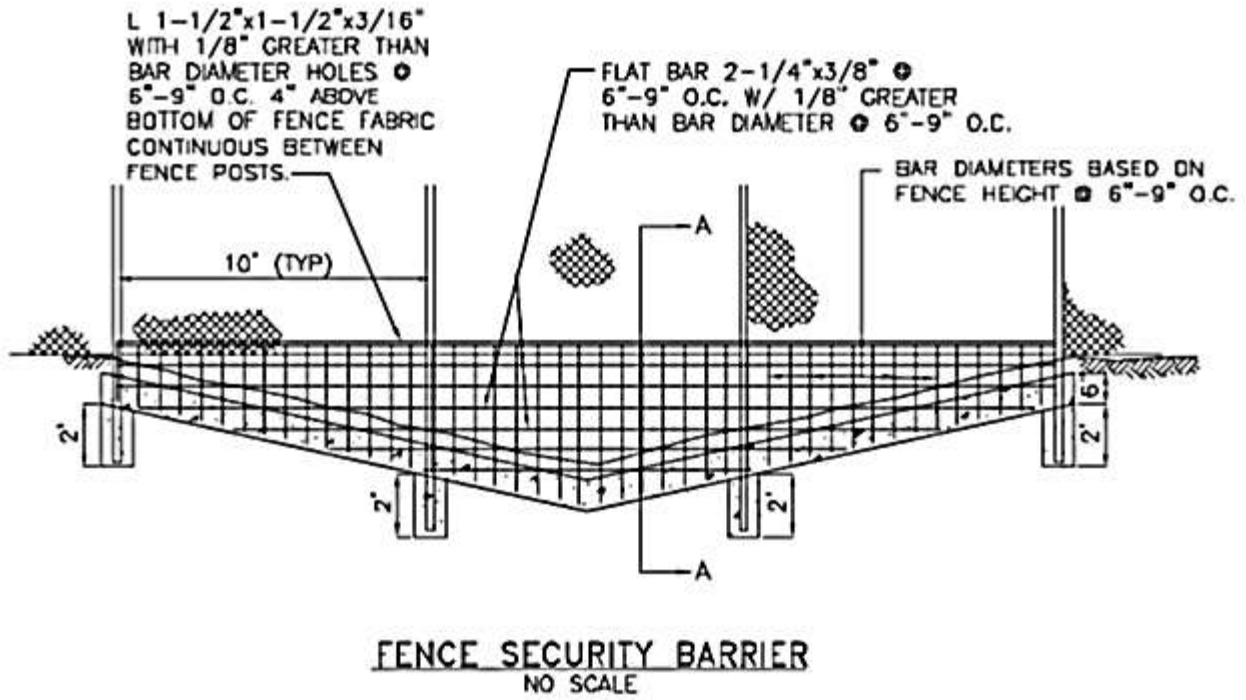
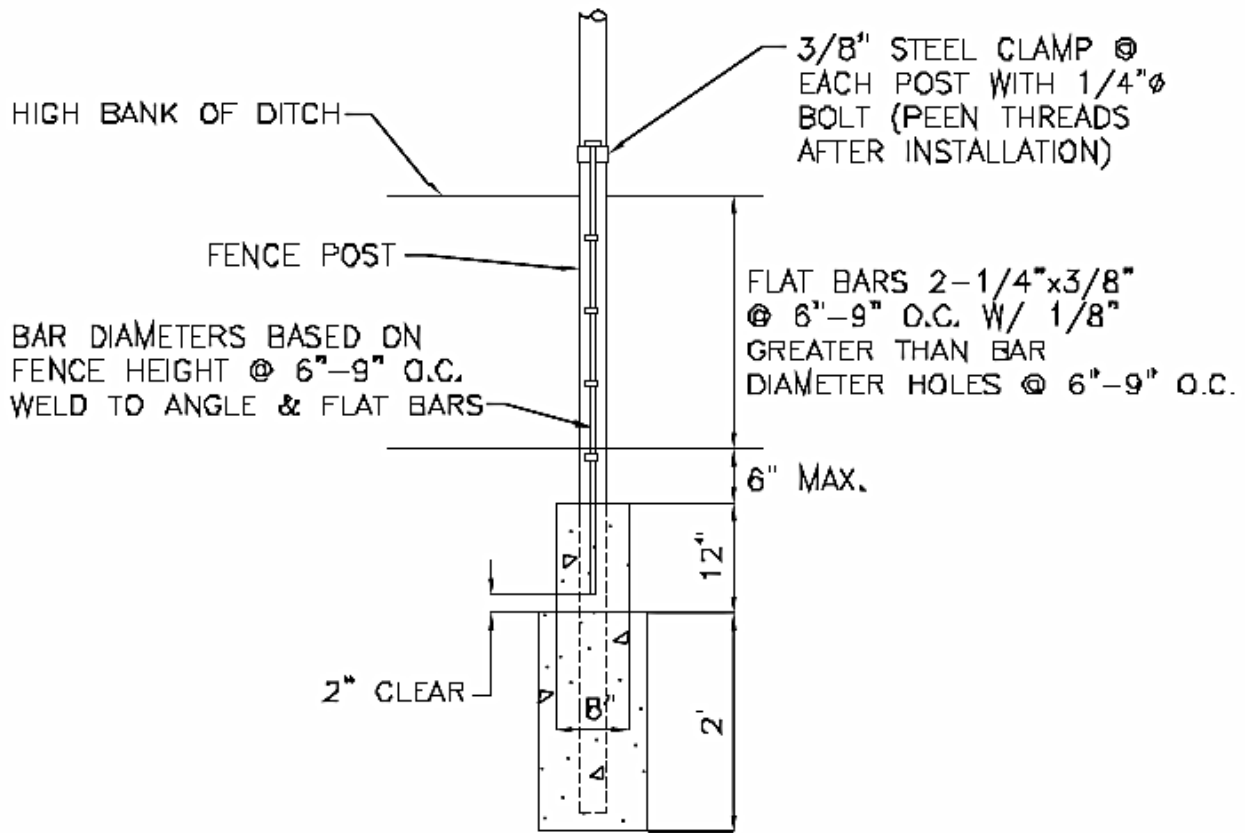

Figure 17  
Bar grill embedded in concrete



**SECTION A-A**  
NO SCALE

Figure 18  
Bar grill embedded in concrete



Figure 19  
Chain link fence over ditch