



PDHonline Course C817 (12 PDH)

River of Oil: The Trans-Alaska Pipeline

Instructor: Jeffrey Syken

2020

PDH Online | PDH Center

5272 Meadow Estates Drive
Fairfax, VA 22030-6658
Phone: 703-988-0088
www.PDHonline.com

An Approved Continuing Education Provider



Table of Contents

<u>Slide/s</u>	<u>Part</u>	<u>Description</u>
1	N/A	Title
2	N/A	Table of Contents
3-63	1	Running on Empty
64-100	2	Native Wealth
101-191	3	One If By Land
192-266	4	Two If By Sea
267-284	5	Three If By Air
285-346	6	Touch the Earth Gently
347-434	7	Safeguarding the Future
435-514	8	Wild Alaska
515-631	9	JFWAT
632-706	10	Trial & Error
707-804	11	Concern No. 3
805-856	12	The Report Card
857-919	13	Turning On the TAPS
920-950	14	A Never Ending Story

2

Part 1

Running on Empty

3

Dead Serious

4

“Anyone who buys who buys one of those big gas-eating cars has got to be out of his mind,’ said the man sitting across the desk from me. For a moment, I couldn’t believe my ears. I’ve heard that kind of talk before, but always from professional car-haters. This time, though, it was coming from one of the top executives in the oil industry - he doesn’t want his name used for obvious reasons - whose livelihood depends on selling lots of gasoline to power lots of cars. But he was dead serious, and he has lots of company...”

Popular Science, April 1973

5

Trouble Ahead

6

"...In several weeks of interviewing experts on energy in general and the oil industry in particular, I got nothing but predictions of desperately hard times ahead for America's auto owners. You'd better get ready for trouble..."
Popular Science, April 1973

7

What Kind of Trouble?

8

"...For one thing, higher prices - and not just a few cents a gallon, either. Almost everyone in the industry thinks the price of gasoline is heading straight up. Before this decade is out, you could well be paying anywhere from 80 cents to one dollar a gallon for your gas. If you can get it, that is..."
Popular Science, April 1973

9

"...If the experts are right, you'd better brace yourself for some kind of gas rationing, maybe as early as this summer. That's no typographical error: Gas rationing, perhaps this year, is what the experts expect. The optimists think it will be informal rationing, when you drive up to the gas pump and the attendant says, 'Sorry, Mr. Jones, I can only give you eight gallons today.' The pessimists look for government-imposed rationing, where the amount of gas you're allowed to buy will depend on how essential your work is..."
Popular Science, April 1973

10

Sooner Rather than Later

11

"... 'It's going to be formal rationing and it's going to be soon,' says Gerard C. Gambbs, a vice-president of the consulting firm of Ford, Bacon & Davis, whose study of energy needs goes back 25 years. 'I don't think the government can allow informal rationing because there just isn't enough gasoline to go around.' John F. O'Leary, an energy expert who is now Director of Licensing of the Atomic Energy Commission and has been Deputy Assistant Secretary of the Interior for Energy Resources, Director of the Bureau of Mines, and Director of the Bureau of Natural Gas, says, 'With 100 million inefficient cars on the road, we may face national rationing this year'..."
Popular Science, April 1973

12

Supply & Demand

13

"...In short, the people who study oil supply and demand are telling you to stop thinking of gasoline of something that is cheap and plentiful, and start thinking of it as scarce and expensive. You may have trouble making that adjustment because the change has happened almost overnight - but if you don't adjust, it's going to hit you hard in the pocket-book..."

Popular Science, April 1973

14

Think Again

15

"...And if you think it can't happen here, think again. It is happening here, right now. Consider these developments, all reported by the nation's newspapers last winter..."

Popular Science, April 1973

16

"...Public schools in Denver and Wichita had to close for lack of heat, even though their suppliers offered to buy fuel oil from anybody at any price. It took the combined efforts of the Office of Emergency Preparedness, the Interior Department, and the Colorado Public Utilities Commission to get enough No. 2 oil - the kind you heat your home with - to reopen the Denver schools part time..."

Popular Science, April 1973

17

"...Three major airlines flying out of New York - American, Trans World, and Allegheny - were sending flights up with tanks only part full, because there wasn't enough aviation fuel to go around. Some normally non-stop flights had to make intermediate stops in order to refuel. At one point the Interior Department had to release imported jet fuel held in bond to prevent a partial shutdown of New York's airports..."

Popular Science, April 1973

18

"...Some major oil companies were rationing supplies. Standard Oil of Indiana told its customers in the Midwest that it could give them only 75 percent of what they wanted. Shell Oil Company was turning away all new customers, while limiting regular customers to the supplies they got last year. Texaco was rationing almost all its fuel oil, as well as diesel and aviation fuel, because of what it called 'unprecedented demand on the dwindling domestic crude oil production'..."

Popular Science, April 1973

19

A Ravenous Demand

20

"...Grain shipments on Midwest waterways were stopped because ships couldn't get the oil to move them. This was no phony shortage caused by a strike or other temporary problem - it was a simple failure to produce enough to meet demand. In one typical week last winter, nearly 21 million barrels of No. 2 oil were produced, up from 18.9 million barrels the year before - a hefty increase, the best that oil companies said they could do, but not good enough to meet a ravenous demand..."

Popular Science, April 1973

RE: in 2005, the U.S. produced an average of 5.4 million barrels of oil-a-day - a little more than half of what it was producing in the mid-1980s. The top three oil-producing areas in the country are the Gulf of Mexico, Texas (onshore) and Alaska's North Slope. Only the Gulf of Mexico was expected to increase output, but the impact of Hurricanes Katrina and Rita hindered productivity. The storms damaged 183 pipelines and destroyed 115 platforms.

21

The Harbinger

22

"...Last winter's shortages of fuel oil are a harbinger of this summer's gasoline shortages. In the ordinary routine, a typical refinery - what people in the oil business irreverently call a 'garbage refinery' to distinguish it from one tailor-made to produce a single specialized product - has about a 15 percent swing in its end product; that is, it can produce anywhere from 35 percent to 50 percent gasoline, depending on demand, with the balance going into the wide variety of products collectively called distillates..."

Popular Science, April 1973

23

"...An average garbage refinery would start switching from its winter balance of 35 percent gas and 65 percent distillates as spring grew near, moving to a 50-50 ratio to build up gas stocks for peak summer travel demand. But instead of cracking heavier distillate molecules into lighter gasoline molecules, the average refinery this winter was frantically turning out all the distillates it could, to keep jet aircraft flying and factories running. The result: no buildup of gasoline stocks, and trouble coming this summer. To repeat, this is no fluke. The oil we need isn't there for the taking. Shortages are here to stay..."

Popular Science, April 1973

24

How?

25

"...How did it happen? How did an oil-rich nation suddenly become oil-poor? The short-term explanation for our shortage is a combination of trends, all bad, that have suddenly converged - in economics, in environmentalism, in technology. Just about everything that could go wrong has gone wrong, putting us in a short-term bind. But there's a more menacing long-term explanation: We (first as a nation and ultimately as a planet) are running out of oil. The petroleum industry used to get a gusher of oil by turning a tap. Now the gush is becoming a trickle. Sure, there's enough crude oil underground to supply the world for maybe a century, but too much of it is in the wrong place as far as the U.S. is concerned. The good old days are over..."
Popular Science, April 1973

26

"...That's true of every form of energy we use, but problems with oil will hit you hardest because oil is both very important and very personal. Half of all the energy used in the United States comes from oil, and half of that oil is used for transportation - most noticeably, the family car. Your coming problems with that car stem in part from trouble with electricity and natural gas..."
Popular Science, April 1973

27

Domino Effect

28

"...If you haven't noticed, we're running out of natural gas. Reserves dropped by 7.1 percent in 1971, the fourth straight year in which the U.S. used more gas than was discovered. 'Last year,' says James Jensen, a senior staff member at Arthur D. Little, Inc., 'the United States had a shortage of 500 billion cubic feet of natural gas, with a total demand of 22 trillion cubic feet. This year, we'll probably have a shortage of one trillion cubic feet.' By federal edict, homes are kept supplied when gas runs short, but industry can be cut off. And when industry is cut off, it looks for other fuels - which means oil..."
Popular Science, April 1973

29

"...Among those scrambling to buy fuel oil are the electric utilities, who find themselves in a double bind: not only are they short of natural gas, but the nuclear plants they expected to have on line have been held up by environmental questions. Gambs calculates that some 30,000 megawatts of nuclear power have been delayed, and that the delay has created extra demand for 300 million barrels of oil a year..."
Popular Science, April 1973

30

Catch 22

31

“...Why don't utilities use the large reserves of coal that the U.S. has underground? There are numerous reasons: air-pollution laws that bar the burning of coal with high sulfur content (meaning just about all of it), wildcat strikes that have cut productivity, new safety regulations that reduce output per man-hour, environmentalist action to stop strip-mining. The amount of coal mined in the United States actually dropped by five percent between 1970 and 1972, despite increased demand. That put more pressure on oil supplies...”
Popular Science, April 1973

32

“...At the same time, the drive to cut exhaust emissions has increased fuel consumption. First, at the refinery: Take low-lead gasoline. You know it costs more, but the reason for that added cost is the extra energy it takes to make low-lead gas. Refiners are used to cracking crude oil into gasoline by a process that gives them an octane rating of about 86 for standard gas and 92 for premium. The refiners add the pinch of tetraethyl lead that brings the gasoline up to the higher octane rating demanded by today's cars...”
Popular Science, April 1973

33

The Hard Way

34

“...Without lead, refiners have to do it the hard way, feeding in more energy to put together short hydrogen molecules into longer ones that bring up the octane rating. That means more of the crude coming into the refinery is consumed right there, putting another drain on limited oil supplies. The situation is bad enough for some refineries to swallow their pride and consider burning coal to produce gasoline...”
Popular Science, April 1973

35

Paying the Price

36

"...Emission controls do horrendous things to gas mileage. Senturion Sciences, Inc., a Tulsa firm, got 14.2 miles per gallon on a 1972 Chevrolet without emission controls and just 9.2 mpg on the same car with emission controls. The exact mileage toll for cleaner air varies from car to car, but the American Petroleum Institute estimates that meeting federal standards will increase gas consumption per new car by 17 percent..."

Popular Science, April 1973

37

"...To put that in more concrete terms, API estimates that a drop in gas mileage of just one mpg for every American car means roughly five billion gallons of gas per year to move American cars the same number of miles. And mileage has been dropping - caused not only by emission controls but also by the tendency for American cars to put on weight. The safety bumpers added to 1973 models - to give just one example - have added significant weight, which requires more gas to push along. All of this helps explain why gasoline consumption is higher than anyone anticipated. Normally, the demand for gas drops steeply after Labor Day. That didn't happen last year, presumably because those gas-hungry 1973 models were hitting the highways. 'The thing that amazed us is how demand held up all through the fall,' says Raymond R. Wright, director of marketing for API. 'There was almost no drop-off at all'..."

Popular Science, April 1973

38

On the Supply Side

39

"...On the supply side, there is the same steady flow of bad news. For example, petroleum companies had hoped to have oil from the newly discovered fields of Alaska's North Slope on the market by now. Worries on the environmental impact of an Alaskan pipeline have pushed that date back to 1976 - at best..."

Popular Science, April 1973

40

"...The same kind of worries have delayed efforts to increase supplies by offshore drilling. Bids for Gulf Coast sites were held up nearly a year for that reason, and the oil industry's hopes for exploring some promising deep-water geological formations off the East Coast have run into outraged resistance from pollution-conscious state governments..."

Popular Science, April 1973

41

The Dismaying Fact

42

“...All this means that the domestic oil fields are producing at flat-out capacity. The dismaying fact is that, for the first time ever, this isn’t good enough. The best our oil fields can do is supply 11.5 million barrels of oil a day, to meet national demand of about 15 million barrels daily. The rest must come from overseas. And things are getting worse, not better. Running oil fields flat-out means a pressure drop; result - production goes down...”
Popular Science, April 1973

43

20/20 Foresight

44

“...‘I said last year we’d be importing 35 percent of our oil needs in 1973,’ says Gambs. ‘Nobody believed me. Now I see the Chase Manhattan Bank is predicting exactly that’...”
Popular Science, April 1973

RE: the U.S. consumes an average of about 20.6 million barrels of oil-a-day. Forty percent of that (9.1 million barrels) is used to power motor vehicles. The U.S. imports roughly half the total - over ten million barrels of crude oil-a-day. Canada is the main source, at nearly 1.8 million barrels. Mexico, Saudi Arabia, Nigeria and Venezuela follow respectively, each exporting more than one million barrels of oil-a-day, with Angola, Iraq, Colombia, Kuwait and Algeria rounding out the “top ten” (each exports between 273K to 641K barrels of oil-a-day).

45

Deficits, Dollars & Nooses

46

“...So why not bring in foreign oil? In a word, money. The dollar is shaky abroad because the U.S. is spending more money overseas than it is bringing in by exports. Foreign oil costs money, and spending too much on foreign oil can increase our trade deficit to the point where the dollar comes crashing down...”
Popular Science, April 1973

47

“...And there are also security reasons: If we depend on foreign oil, the nations that supply that oil have our neck in a noose, a fact that is prodding the National Security Council to conduct a study on energy...”
Popular Science, April 1973

48

Dollar-a-Gallon

49

"...The National Petroleum Council, which just finished an intense study of future energy needs, estimates that by 1985 we could be importing half our oil, and spending \$25 billion a year. Horrendous as that sounds to economists, Gambbs thinks it's on the optimistic side: 'If current trends continue,' he says, 'the trade deficit for oil in 1985 could be over \$5 billion a year.' That's why the experts are talking about dollar-a-gallon gas. The reason why gas costs 80 cents a gallon in Europe is not production costs but foreign exchange: European governments, which have no domestic oil fields, have slapped on whopping taxes to keep consumption down and reduce their trade deficit. The United States is rapidly moving into the same position..."

Popular Science, April 1973

50

More Right than Wrong

51

"...Even finding more domestic oil will raise prices. One of the arguments the petroleum industry is fond of repeating is that federal policies - such as the reduction of the depletion allowance from 27.5 percent to 22.5 percent - has discouraged oil exploration, helping to create the present shortage. Disturbing though it may be to populists, many economists believe the industry is more right than wrong..."

Popular Science, April 1973

52

Small Wonder

53

"...Consider one statistic: The average cost of drilling oil wells in the U.S. in 1971 was \$19.03 a foot, up 48 percent over the 1961 cost. And the average depth of an oil well was 4,787 feet on dry land, 10,189 feet offshore. Faced with booming costs, it's small wonder the industry cut back the number of new wells to just over 25,000, down more than 2,000 from 1970 and less than half the 57,000 wells drilled in the peak year of 1956..."

Popular Science, April 1973

54

"...Given those figures, most experts believe the oil industry is justified in asking higher prices, but you'll have to foot the bill. Unless we're willing to pay the price, the domestic shortage inevitably will get worse. 'One of the incredible things about the oil shortage is that the people who were most nervous were the people who had the most to gain economically from the idea of shortages, so nobody took them seriously.' Says James Jensen of Arthur D. Little..."
Popular Science, April 1973

55

A Tragic Lapse

56

"...Jensen and others point out that things might be better today if we had made the right technological decisions a few years ago. In retrospect, our energy-research policy looks pretty dreary. Says John F. O'Leary, the energy expert now with the Atomic Energy Commission: 'There has been a tragic lapse in the U.S. in developing alternatives to our on-going energy problem. One result is that if we look for technologies to convert coal to gas, we have to go to the English; for converting liquid fuels to gas we have to go to the Germans and Japanese'..."
Popular Science, April 1973

57

Between Here and 1985

58

"...in the fuel-short days ahead, the experts have a unanimous recommendation for our survival as a society: massive and intelligent research programs on every possible source of energy, including the breeder reactor, fusion power, geothermal energy, solar power. Energy research and development might not head off the gasoline gap between here and 1985, but it is our only hope for getting out of the energy quagmire of the 1970s."
Popular Science, April 1973

59



60

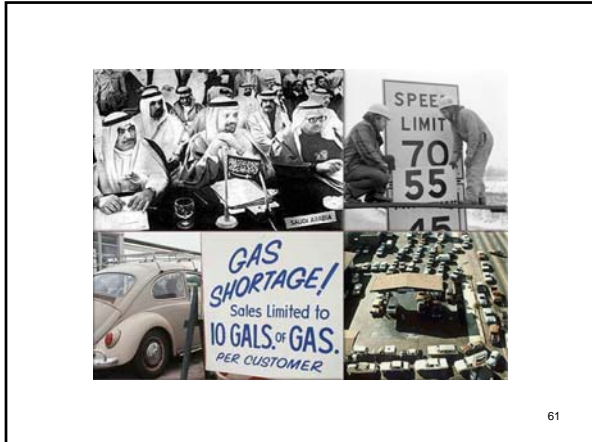

61



62



63

Part 2

Native Wealth

64

Pinch, Crunch or Crisis

65

"Whether you call it a pinch, crunch or crisis, the fact is we're running out of the stuff that makes everything go: jets in the sky, industrial machines, your auto, the furnace in your home, the toaster on the breakfast table. They all take their large or small bite out of the energy pie..."
Popular Mechanics, December 1973

66

BTUs and U

67

“...The average American is the world’s greatest consumer of energy, according to statisticians at the Department of the Interior’s Office of Coal Research. They figure it this way: Divide the total energy used in the United States on a per capita basis and you get 390 BTUs (British Thermal Units) consumed annually per person (the energy involved equals 15 tons of coal). In contrast, the average Briton ‘consumes’ 170 million BTUs annually; the West German, 140 million, and the Brazilian about 20 million...”
Popular Mechanics, December 1973

68

Pieces of the Pie

69

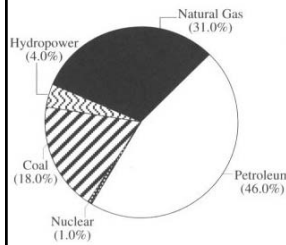

“...Basic energy sources being tapped today include the fossil fuels - oil, coal and natural gas - and several of lesser importance. These include hydropower, nuclear power (uranium) and geothermal energy...”
Popular Mechanics, December 1973
 Left: caption: “Sources of U.S. Energy Supply: 1973”

70

“...Natural gas, cleanest of fuels, is running out fast. If we don’t find new reserves within the United States, we could burn up what we have in only 12 years. That’s the estimate of Mr. Philip N. Ross, manager of power systems planning at Westinghouse Electric Corp. Natural gas makes up only 3 percent of our energy supply but accounts for 32 percent of our use...”
Popular Mechanics, December 1973

71

End of an Age?

72

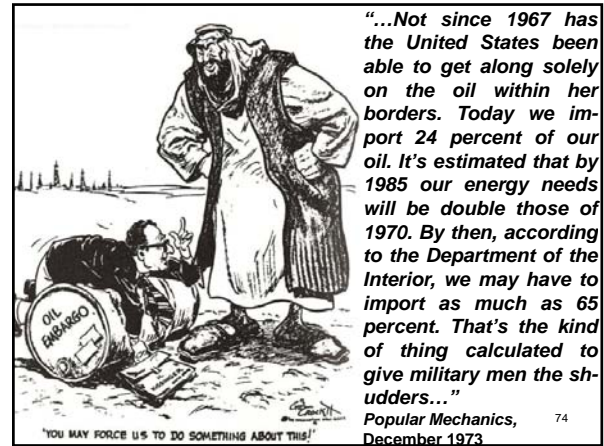
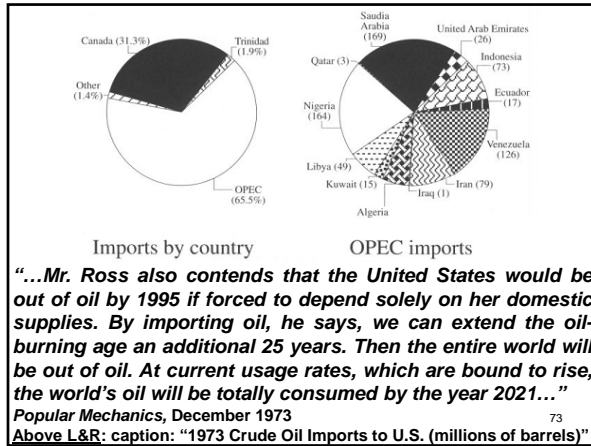

The Ancient Fuel

75

“...Some power experts say we might as well write off oil and turn to coal - the ancient fuel that’s earned such a dirty name. ‘we should place essentially no dependence on oil and natural gas in the long run,’ says Philip Ross. ‘Coal I foresee as being an increasingly precious commodity. Through its synthesis into petroleum and gaseous forms, it must furnish the needs of the petrochemical industry and the fuel for trucks and aircraft. The critical position coal holds in this nation’s energy future cannot be overemphasized, for it is also the energy source upon which we will lean most heavily to effect the difficult transition from where we are today to the ultimate nuclear energy economy’...”
 Popular Mechanics, December 1973 76

Greatest Asset

77

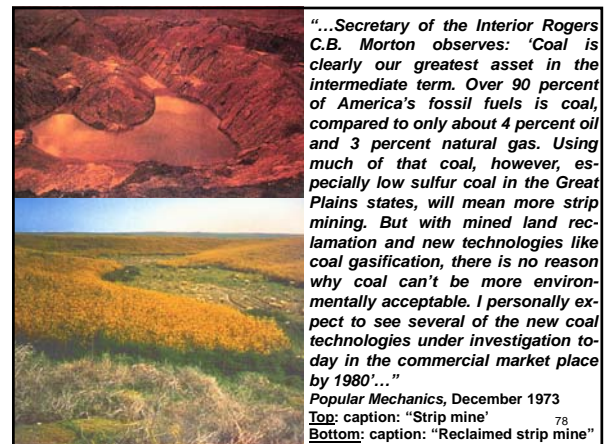



79

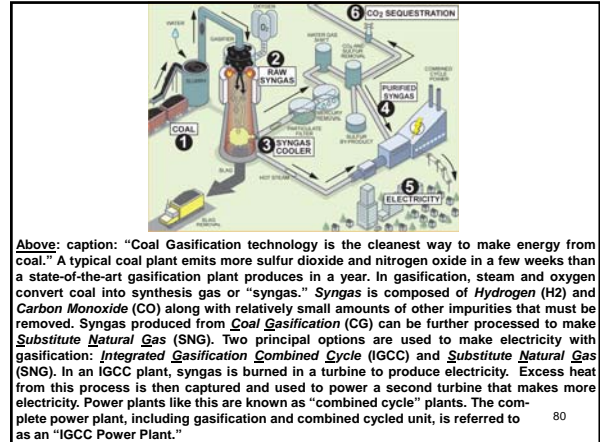

Above: caption: "Coal Gasification technology is the cleanest way to make energy from coal." A typical coal plant emits more sulfur dioxide and nitrogen oxide in a few weeks than a state-of-the-art gasification plant produces in a year. In gasification, steam and oxygen convert coal into synthesis gas or "syngas." Syngas is composed of Hydrogen (H2) and Carbon Monoxide (CO) along with relatively small amounts of other impurities that must be removed. Syngas produced from Coal Gasification (CG) can be further processed to make Substitute Natural Gas (SNG). Two principal options are used to make electricity with gasification: Integrated Gasification Combined Cycle (IGCC) and Substitute Natural Gas (SNG). In an IGCC plant, syngas is burned in a turbine to produce electricity. Excess heat from this process is then captured and used to power a second turbine that makes more electricity. Power plants like this are known as "combined cycle" plants. The complete power plant, including gasification and combined cycled unit, is referred to as an "IGCC Power Plant."

80



81

Pipeline Quality

82

"...The United States has more coal deposits than any other country. Some 3 trillion tons lie buried beneath American soil, two-thirds of it said to be recoverable by current methods. The Office of Coal Research, in cooperation with private power companies and research organizations, is pushing various programs for the development of efficient ways to convert coal into pipeline quality gas, into an industrially useful oil, and into a 'cleaner' solid that can be used directly as a fuel. The gas could be piped to factory and the home. Or, like the oil and the solid fuel, it could be used to generate electricity, the form of energy that's vital to a society such as ours. The problem is that electrical generation is very inefficient. Some 60 percent of the energy value of a fossil fuel is lost in the conversion process..."
Popular Mechanics, December 1973

83

"...Farthest along of the new coal gasification methods is that used in the HyGas plant in Chicago. The plant is designed to convert 75 tons of coal a day to 1.5-million cu. ft. of high-quality gas. In this process, coal is mixed with a light oil (a byproduct of the process and this slurry is heated in the reactor. Chemical reactions and heat exchanges cause the coal to give off most of the gases. Refining removes sulfur in its elemental form - not as a gas but a non-polluting and valuable solid..."
Popular Mechanics, December 1973
 RE: the HyGas Process takes a coal-oil slurry and its resultant gases through a complex series of steps. The original heat source is electricity. Many of the later steps refine the final products - a char with appreciable heating values retained and a gas of pipeline quality.

84

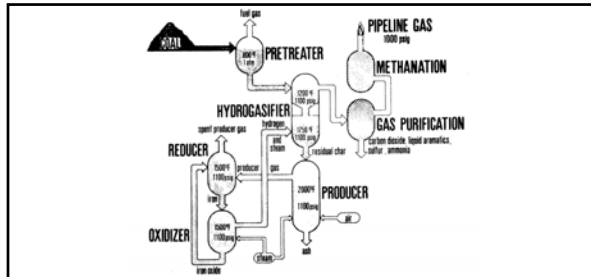

Above: caption: "Flow diagram of the steam-iron process integrated with the HyGas process." The steam-iron system comprises three principal vessels: 1) the producer, in which residual HyGas char is converted to reducing gases; 2) the reducer, in which iron oxide is reduced with producer gas, and; 3) the oxidizer, in which the iron is re-oxidized and the hydrogen is produced. In integrated operation, spent char from the HyGas process is fed directly to a producer vessel in which it reacts with air and steam to generate a gas capable of reducing iron oxide to iron. In actual operation, the producer zone is contained within the hydrogasifier pressure shell. 85

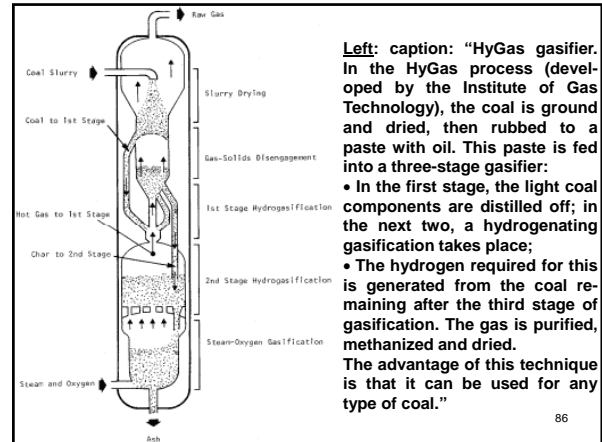

Left: caption: "HyGas gasifier. In the HyGas process (developed by the Institute of Gas Technology), the coal is ground and dried, then rubbed to a paste with oil. This paste is fed into a three-stage gasifier: • In the first stage, the light coal components are distilled off; in the next two, a hydrogenating gasification takes place; • The hydrogen required for this is generated from the coal remaining after the third stage of gasification. The gas is purified, methanized and dried. The advantage of this technique is that it can be used for any type of coal." 86

Our Friend the Atom

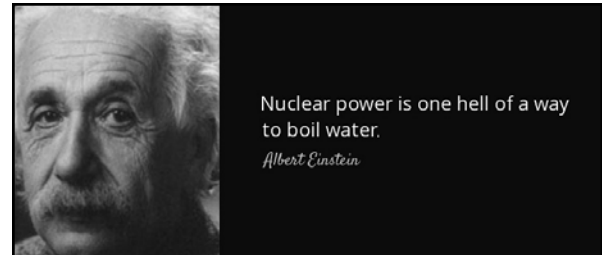

"...Though our coal resources could last several hundred years, many experts continue to look toward nuclear energy as the ultimate solution to our problems. They expect to see a big boost in the output of conventional nuclear plants, which today represent but 4 percent of our electrical generating capacity. According to an Atomic Energy Commission projection, this could be raised to 30 percent by 1985..." 88
Popular Mechanics, December 1973

"...This would be an intermediate stage. Philip Ross and other experts look to the breeder reactor to carry us far into the 21st century. This type of reactor not only provides power by producing energy in the form of heat, but it also 'breeds' new fuel. It converts a non-fissionable form of uranium into plutonium 239, a highly fissionable fuel. This is of critical importance because conventional reactors, using uranium-235, are even more efficient than fossil generating plants in providing energy for the production of electricity. They waste such large amounts of fuel (in the form of heat) that in a few decades we might run out of easily mined uranium..." 89
Popular Mechanics, December 1973

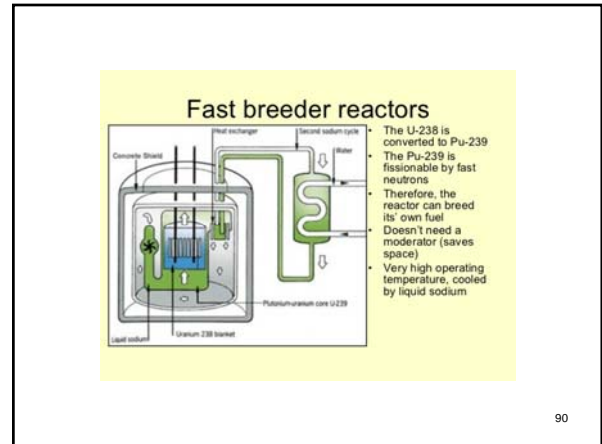

Fast breeder reactors

- The U-238 is converted to Pu-239
- The Pu-239 is fissionable by fast neutrons
- Therefore, the reactor can breed its own fuel
- Doesn't need a moderator (saves space)
- Very high operating temperature, cooled by liquid sodium

Options on the Table

91

Oil shale deposits could provide relief
 An estimated two trillion barrels of oil - in the form of oil shale - located deep in the western United States may be a key to easing dependence on shrinking foreign oil supplies.

Oil shale deposits
 Low yield or unappraised deposit
 High yield - 25 gallons of oil or more per ton of shale

Top in-place shale oil resources, in billions of barrels*

U.S.	210
China	150
U.S. (excluding Alaska)	100
Canada	50
U.S. (excluding Alaska and Canada)	25
Other countries	10

*Data measured in U.S. barrels which contain 42 gallons per barrel.

“...Other energy sources are either limited or far out of reach now. Hydroelectric power can only make a limited contribution. Geothermal energy, obtained by tapping the heat of the earth itself, is a subject of controversy. There are researchers who say its contribution will always be limited...Other sources of oil are the very large deposits contained in the mountains of shale found principally in Colorado, Utah and Wyoming. One problem is how to ‘boil-off’ the oil in an economical way. Another problem is ecological - what to do with the hills of spent shale...”
*Popular Mechanics, December 1973*⁹²

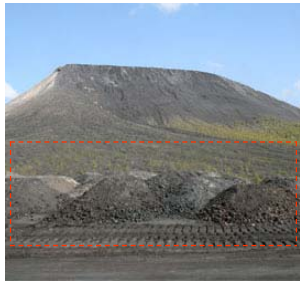

93



“...Solar power is in a similar state of development. Though its potential is great - it's a source of energy that will last as long as the sun - we're only beginning to develop systems to capture its energy on a large scale...”
Popular Mechanics, December 1973

Above L&R: caption: “Spain’s Gemasolar Array is the World’s First 24/7 Solar Power Plant.” In 2011, *Torresol Energy* overcame one of solar energy’s biggest challenges: operating when the sun doesn’t shine. The 19.9 MW *Gemasolar Concentrated Solar Power Plant* in Spain’s *Andalucia Province* has two tanks of molten salt (MSES) that store heat energy generated throughout the day. Unlike normal plants that have less thermal storage or none at all, this stored energy enables *Torresol* to satisfy peak summer energy demand long after sunset. *Gemasolar* was expected to produce approximately 110K MWh of energy each year – enough to power 25K homes.

94



95

The Ultimate Energy

96



“...The ultimate energy, say many scientists, is thermo-nuclear fusion. Its promise has been evident ever since the first hydrogen bomb was exploded - an uncontrolled fusion reaction. The problem, which the best scientific brains are working on, is how to control a fusion reaction. This energy source is virtually limitless...”

Popular Mechanics, Dec. 1973
 Left: mushroom cloud from an American H-bomb test over the Marshall Islands - April 12th 1954 cover of TIME 97

THE HYDROGEN CHALLENGE
 The future of hydrogen fuel cell vehicles depends on advances in four key areas: the hydrogen source, the distribution infrastructure, the on-board fuel tank, and the on-board fuel cell.

Source
 Hydrogen must be derived from carbon-free renewable sources before fuel cell vehicles can make a dent on the climate problem. One idea is to make the hydrogen by splitting water using electricity from wind farms, solar panels or nuclear plants.

Infrastructure
 Once the hydrogen is made, it must be distributed via special pipelines and tanks to an extensive network of hydrogen refueling stations. But who will buy the vehicles if the stations don't exist? And who will invest in the stations if the vehicles don't exist?

Fuel cell
 This device converts hydrogen to electric power. The challenge is to make it light, cheap, robust and durable — yet powerful enough to run the engine, lights and air conditioning.

Fuel tank
 Fuel cell vehicles must store enough hydrogen to go several hundred kilometers between refueling stops. Liquid hydrogen requires insulated tanks at -253 °C. Do most companies have the capacity to compress the hydrogen inside high-strength carbon-fiber tanks?

“...Fusion uses heavy water, which can be extracted from the sea. Using fusion power, we can then take more energy from the sea in the form of hydrogen. Who knows, maybe 50 years from now Americans will drive cars powered by a non-polluting ‘tiger in the tank’ called hydrogen.”
 Popular Mechanics, December 1973
 Above: caption: “The Hydrogen Challenge” 98

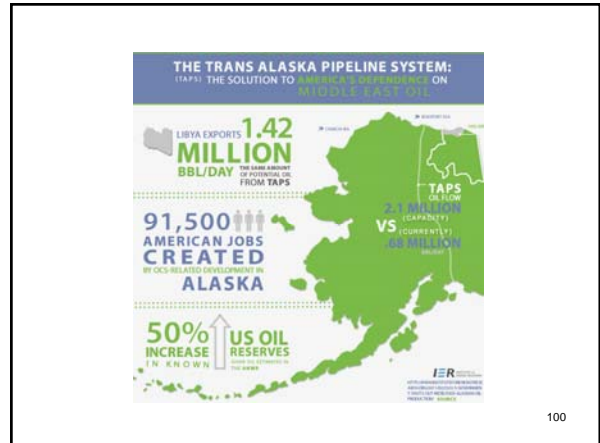
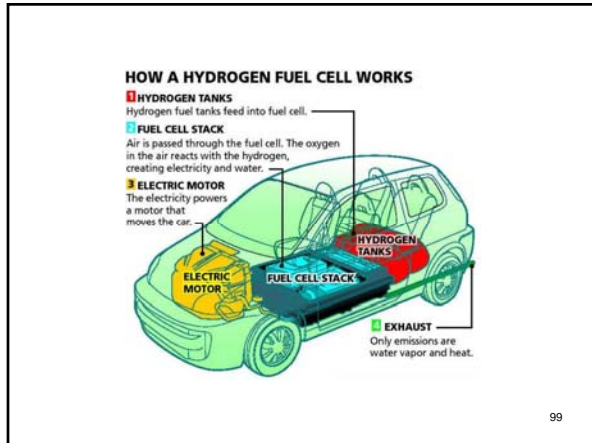

Part 3
One If By Land

Icebound



"The huge oil reserves on Alaska's North Slope - estimated at from 10 to 30 billion barrels - have bred controversy since their discovery in 1968. Because Prudhoe Bay is ice-bound for most of the year, the oil can't be taken out by conventional tanker. Thus, the oil companies developing the area plan to build the Trans-Alaska Pipeline System (TAPS) to move the crude across the state's landmass from Prudhoe to the ice-free port of Valdez - on the Gulf of Alaska about 100 miles east of Anchorage. From there it would be shipped to the lower 48 states..."
Popular Mechanics, January 1974

103

The Prudhoe Bay Oil Field is the largest oil field in both the U.S. and North America. The field is located in Alaska on its North Slope and covers 213,543 acres. When first discovered, the oil field contained approximately 25 billion barrels of oil. The amount of recoverable oil in the field is twice that of the next largest oil field in the U.S. (the East Texas Oil Field). The Prudhoe Bay field was discovered on March 12th 1968 by the Atlantic Richfield Company (ARCO) and Exxon (formerly ESSO - a/k/a Humble Oil & Refining Company) with the well: "Prudhoe Bay Slate No. 1." The lead geologist to find the drilling sites for the discovery and confirmation wells was Marvin Mangus. The formation that oil and natural gas are produced from is the Triassic, Ivishak sandstone in the area. Oil is trapped in the Sadlerochit formation, which is a sandstone and gravel structure nearly 9K-feet below the Earth's surface. In March of 2006, BP discovered a large oil spill in the western part of Prudhoe Bay. The spill was due to corrosion in the pipeline, which allowed 267K gallons of oil to be spilled. Because of the spill, BP was forced to shut down operations, which caused worldwide oil prices to rise and the State of Alaska to lose \$6.4 million each day until production was resumed.

104



When oil was discovered on Alaska's North Slope, it was the single largest field ever found in North America. The 27 square-mile oil field (above) was small in size, but prolific in volume (by 2006, it had produced 15 billion barrels of oil). In 1988, TAPS hit its peak, transporting 2.02 million barrels of oil-a-day. However, since then it has been in decline. There has been only one other big find in Alaska (Alpine), but it's small in comparison to Prudhoe Bay. As the production of easy-to-pump grades of oil declines, companies like British Petroleum are trying to extend the life of Prudhoe Bay as an extraction site by using new technologies to wring more oil out of the rock. They're targeting heavy oils, which often have the consistency of molasses, that are generally considered too costly to extract.

105

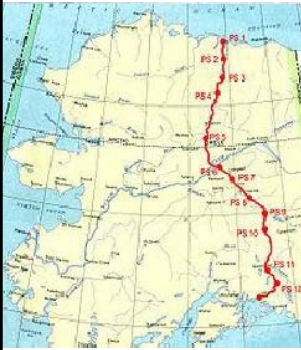

The Trans-Alaska Pipeline System (TAPS) is one of the largest pipeline systems in the world containing eleven pump stations, the several hundred miles of feeder pipeline and the Valdez Marine Terminal. TAPS was built between 1974 and 1977 (mainly due to the Mid-East oil crisis of 1973 which caused a sharp rise in prices and shortages). Legislation had to be passed to remove legal challenges in order for the pipeline to be built due to environmental, legal and political debates following the discovery of oil at Prudhoe Bay in 1968. Building the pipeline was not easy due to a wide range of difficulties that resulted from extremely cold temperatures and the isolated terrain of the Alaskan wilderness. Permafrost and frozen ground had to be dealt with in order to complete the pipeline. Boomtowns rose in Valdez, Fairbanks and Anchorage due to the thousands of workers drawn to the project.

106

Oil Men and Ecologists

107

"...For years, oil men and ecologists have been at loggerheads over the proposed pipeline. At this writing, it seems the oilmen, with an assist from the energy crisis, have all but won the battle. Bills to permit the building of a pipeline have passed both houses of Congress. By the time you read this, it's likely that the President will have signed a bill into law..."
Popular Mechanics, January 1974

108



The *Trans-Alaska Pipeline Authorization Act* was signed by POTUS *Richard M. Nixon* on Friday, November 16th 1973 (left). It authorized the building of an oil pipeline connecting the *North Slope of Alaska* to *Port Valdez* and specifically halted all legal challenges that had been filed primarily by environmental activists who were against construction of the pipeline. A federal right-of-way for the pipeline and transportation highway was granted on January 3rd 1974 and the deal was signed by the oil companies on January 23rd 1974, allowing construction work to begin on the 800-mile-long pipeline.

109



Trans-Alaska Pipeline System

"...But that won't keep the environmentalists quiet. They warn that the pipeline could damage the permafrost through heat transfer, cause further pollution through oil leakage and obstruct the migration of the caribou. The relatively untouched Alaskan environment could be seriously affected - and not for the better..."
Popular Mechanics, January 1974
 Left: caption: "Trans-Alaska Pipeline route map with pump station locations and photos"

110

Is There an Alternative?

111



*"...Perhaps the most imaginative and comprehensive proposal is the *Integrated Pipeline Transportation (IPT)* system, the brainchild of *T.Y. Lin*, a Chinese born civil engineer recognized as one of the world's leading designers of prestressed concrete bridges and buildings. Lin is on the faculty at the *University of California, Berkeley*, and a busy consultant..."*
Popular Mechanics, January 1974
 Above: *Tung-Yen Lin* (a/k/a "*T.Y. Lin*") was born on November 14th 1912 in Fuzhou, China. He died on November 15th 2003, one day after his 91st birthday.

112

Yesterday's Way

113



"...The TAPS approach represents conventional engineering and, to Lin, is 'yesterday's way to build a oil pipeline.' According to the Department of the Interior, which has the responsibility of okaying the pipeline, about half the length of the 789-mile TAPS pipe would be buried, the other half supported above the ground at heights from two to eight feet..."
Popular Mechanics, January 1974

114

Popular Mechanics
 JAN 1974 60 CENTS
 YOUNG MECHANICS: Win Plymouth's Trouble-Shooting Contest Page 108
BOLD PROPOSAL: A BRIDGE FOR ALASKAN OIL Page 104
 MODULAR FURNITURE: You can build it Page 62
 MOTORCYCLES: What it takes to compete Page 78
 BOAT SAFETY: Stopping? Page 74
 SCOWS: New for '74 Page 74
 PICKUP CAMPER: Build it for under \$150 Page 66
 KNOW-HOW: How to fix a freezer How to bang wallpaper How to use plastic pipe

“...In contrast, the IPT would be a tubular concrete structure supported at 300-foot intervals by bridge-type piers. The big tube could accommodate as many as six pipelines and could also function as a transportation artery. Its upper deck, or decks, could be used by autos, trucks and/or and electrified rail system. In effect, the IPT would be a 789-mile bridge from Prudhoe to Valdez 30 ft. above ground along its entire route...”
 Popular Mechanics, January 1974 115

An Engineering Nightmare

116

“...If you ignore environmental aspects, a conventional pipeline seems the cheapest and best solution to the need of getting Alaskan oil to market. But when the land is the Alaskan peninsula, and the route crosses three mountain ranges, 350 rivers and streams, and runs through permafrost and earthquake faults, the project becomes an engineering nightmare...”
 Popular Mechanics, Jan. 1974 117

“...The climate is hostile. In the extreme north, the sun is not seen for almost two months a year. Temperatures can drop to minus 80-degrees Fahrenheit in interior areas and winds of 40 mph are common...”
 Popular Mechanics, January 1974 118

Perennially Frozen

119

“...Permafrost is the name for soil and sediment, often with high water content, which in the arctic becomes perpetually frozen ground. At the northern oil fields the permafrost is some 2,000 feet thick but thins out further south, eventually disappearing...”
 Popular Mechanics, January 1974
 Above: caption: “Permafrost, or perennially frozen soil and rock, is continuous in northern Alaska, discontinuous in a wide band in the central part of the State, and absent in southern and southeastern areas near the coast” 120

Trans Alaska Pipeline

800 miles long
Friction heats all up to ~145°F. Would melt surrounding ground!
380 miles in North Alaska insulated and buried.
Pumping Stations (10) and 4 miles of pipeline mechanically refrigerated

“...Permafrost is stable but, environmentalists say, will melt from the heat of the 140-degree Fahrenheit oil pumped through a pipeline such as TAPS (the oil must be warm to keep flowing). In that event, sections of the pipeline would eventually be floating in a slurry instead of being supported by anything solid...”
Popular Mechanics, January 1974
Left: caption: “380 miles of pipeline are insulated and buried, a few miles with active refrigeration, most without”

121

The formation of Ice wedges

Active Layer
Permafrost
Surface (0m)
1m
2m
3m
Depth from surface

“...Ice wedges - massive vertical veins of ice which form tight polygonal networks invisible from the surface and difficult to delineate through borings - are another widely distributed permafrost hazard. The thawing of ice wedges, according to a U.S. Geological Survey study, could also cause settling, resulting shearing stresses in the pipe...”
Popular Mechanics, January 1974
Above: caption: “The following series of graphics showing the evolution of ice wedges. The development of an ice wedge begins with cold temperatures in winter forming a crack in the ground surface that is about a meter deep and a few millimeters wide. In the warmer months, melting of the active layer liberates liquid water which flows into the crack. This water then freezes on contact with the permafrost. The cycle just described repeats itself year after year with new cracks forming in the developing ice wedge. The two graphics on the right show a well developed ice wedge after many cycles of development.”

122

Pingo
Low centered Polygons
Troughs in between ice wedges
Basin
Ice wedges
Permafrost

Polygon rims
Trough
Basin
Active layer
Permafrost
Ice wedge

123

124

125

Seismicity

126



“...Shearing stress - a term for forces that can snap a pipeline - also can result from earthquakes. Seismic vibrations could cause loosely packed sands and silts to liquefy, leaving stretches of pipeline unsupported...”

Popular Mechanics, January 1974

RE: a key feature of TAPS is that for more than half of its length, it sits above ground. Sections are kinked to allow for flexibility and in some areas, metal rails support the pipe at intervals along a wide, level gravel pad. The pipeline sits perpendicular to the rails on Teflon sliders, allowing it to shimmy back and forth under stress.

127

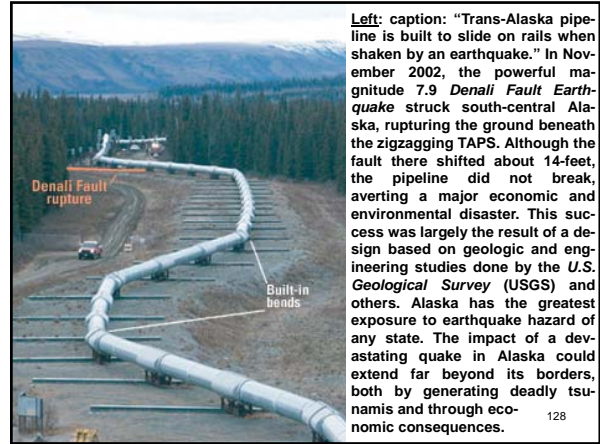

Left: caption: “Trans-Alaska pipeline is built to slide on rails when shaken by an earthquake.” In November 2002, the powerful magnitude 7.9 Denali Fault Earthquake struck south-central Alaska, rupturing the ground beneath the zigzagging TAPS. Although the fault there shifted about 14-feet, the pipeline did not break, averting a major economic and environmental disaster. This success was largely the result of a design based on geologic and engineering studies done by the U.S. Geological Survey (USGS) and others. Alaska has the greatest exposure to earthquake hazard of any state. The impact of a devastating quake in Alaska could extend far beyond its borders, both by generating deadly tsunamis and through economic consequences.

128



“The original pipeline design accommodated 6.1 m (20 ft) horizontal and 1.5 m (5 ft) vertical movement at the Denali Fault Crossing...Due to a rigorous design which took into account seismic activity similar to the 2002 Denali earthquake, the pipeline withstood the ground movement at the fault...”

TAPS Senior Engineer
RE: in November 2002, a magnitude 7.9 earthquake rocked the Denali Fault, which is crossed by TAPS – there were no pipeline failures due to the intense seismic movement

129



“...This possibility becomes a serious threat to a pipeline with a route that crosses seven fault zones, three of which are highly active. Hundreds of earthquake shocks are noted in Alaska every year. Much of the \$300 million damage of the 1964 Alaskan earthquake occurred in the vicinity of Valdez, the southern terminal of the TAPS line...”

Popular Mechanics, January 1974

Left: caption: “The Good Friday Alaska Earthquake and Tsunami of March 27, 1964”

130

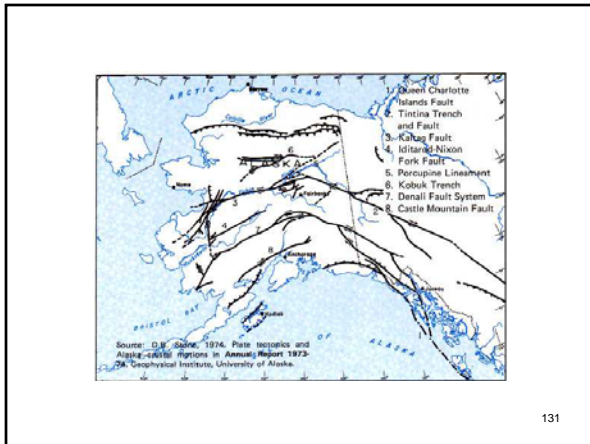

Source: D.W. Moore, 1974. Plate tectonics and Alaska, 1974. Reprinted in Annual Report 1973-74, Geophysical Institute, University of Alaska.

131

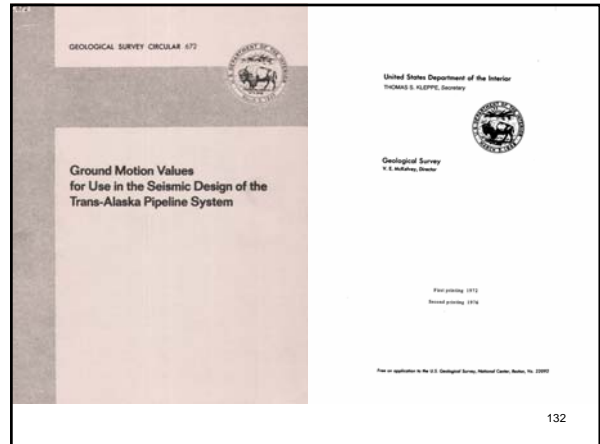

132

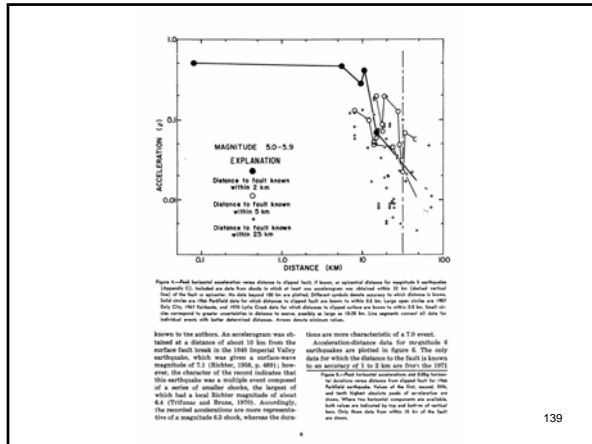

Figure 4—Peak horizontal acceleration versus distance to closest fault for several different distances for magnitude 5.0-5.9 earthquakes (Figure 2). Included are data from shocks in which the maximum was observed within 10 km (filled circles) and data from shocks in which the maximum was observed between 10 and 25 km (open circles). Data from shocks in which the maximum was observed between 25 and 50 km are shown as open squares and open triangles. Data from shocks in which the maximum was observed between 50 and 100 km are shown as open diamonds. Data from shocks in which the maximum was observed between 100 and 200 km are shown as open squares with a diagonal slash. Data from shocks in which the maximum was observed between 200 and 500 km are shown as open diamonds with a diagonal slash. Data from shocks in which the maximum was observed between 500 and 1000 km are shown as open diamonds with a diagonal slash.

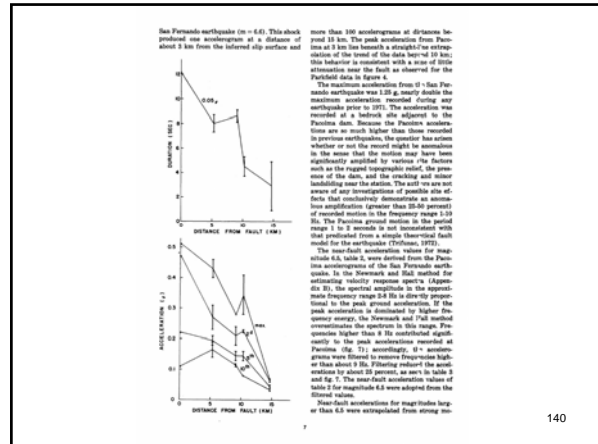

Figure 5—Peak horizontal acceleration versus distance to closest fault for several different distances for magnitude 6.0-6.9 earthquakes (Figure 2). Included are data from shocks in which the maximum was observed within 10 km (filled circles) and data from shocks in which the maximum was observed between 10 and 25 km (open circles). Data from shocks in which the maximum was observed between 25 and 50 km are shown as open squares and open triangles. Data from shocks in which the maximum was observed between 50 and 100 km are shown as open diamonds. Data from shocks in which the maximum was observed between 100 and 200 km are shown as open squares with a diagonal slash. Data from shocks in which the maximum was observed between 200 and 500 km are shown as open diamonds with a diagonal slash. Data from shocks in which the maximum was observed between 500 and 1000 km are shown as open diamonds with a diagonal slash.

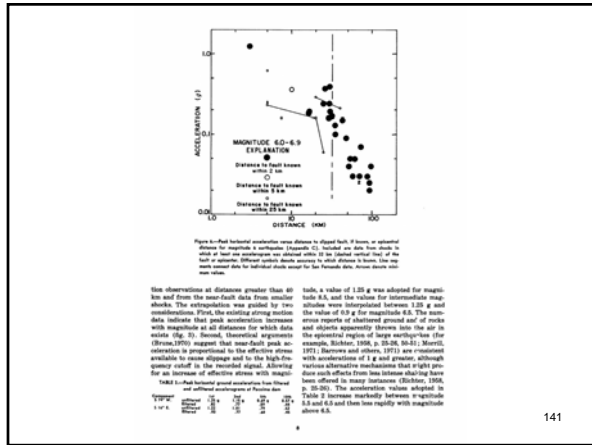

Figure 6—Peak horizontal acceleration versus distance to closest fault for several different distances for magnitude 7.0-7.9 earthquakes (Figure 2). Included are data from shocks in which the maximum was observed within 10 km (filled circles) and data from shocks in which the maximum was observed between 10 and 25 km (open circles). Data from shocks in which the maximum was observed between 25 and 50 km are shown as open squares and open triangles. Data from shocks in which the maximum was observed between 50 and 100 km are shown as open diamonds. Data from shocks in which the maximum was observed between 100 and 200 km are shown as open squares with a diagonal slash. Data from shocks in which the maximum was observed between 200 and 500 km are shown as open diamonds with a diagonal slash. Data from shocks in which the maximum was observed between 500 and 1000 km are shown as open diamonds with a diagonal slash.

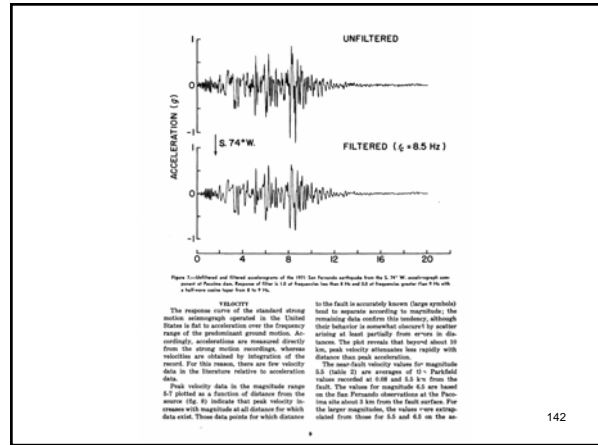

Figure 7—Displacement and three components of the 1971 San Fernando earthquake from the S. 74° W. component (component of the motion in the direction of the fault) recorded at station 10. The top plot shows the unfiltered acceleration and the bottom plot shows the filtered acceleration. The vertical line marks the time of the main shock. The top plot shows the unfiltered acceleration and the bottom plot shows the filtered acceleration. The vertical line marks the time of the main shock.

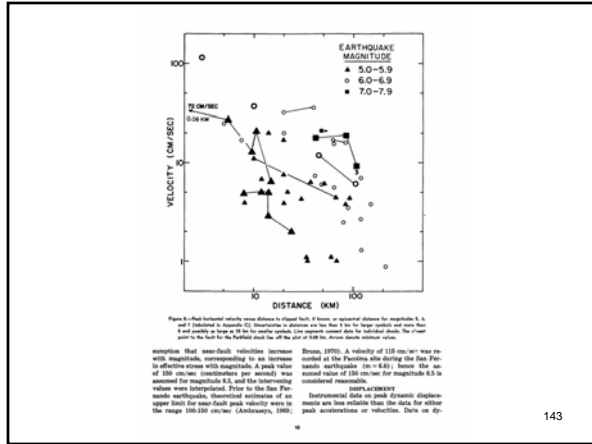
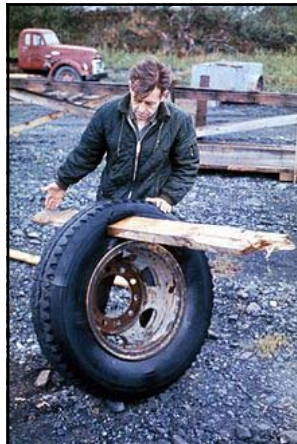

Figure 8—Peak horizontal velocity versus distance to closest fault for several different distances for magnitude 5.0-5.9 earthquakes (Figure 2). Included are data from shocks in which the maximum was observed within 10 km (filled circles) and data from shocks in which the maximum was observed between 10 and 25 km (open circles). Data from shocks in which the maximum was observed between 25 and 50 km are shown as open squares and open triangles. Data from shocks in which the maximum was observed between 50 and 100 km are shown as open diamonds. Data from shocks in which the maximum was observed between 100 and 200 km are shown as open squares with a diagonal slash. Data from shocks in which the maximum was observed between 200 and 500 km are shown as open diamonds with a diagonal slash. Data from shocks in which the maximum was observed between 500 and 1000 km are shown as open diamonds with a diagonal slash.



Figure 9—Peak horizontal velocity versus distance to closest fault for several different distances for magnitude 6.0-6.9 earthquakes (Figure 2). Included are data from shocks in which the maximum was observed within 10 km (filled circles) and data from shocks in which the maximum was observed between 10 and 25 km (open circles). Data from shocks in which the maximum was observed between 25 and 50 km are shown as open squares and open triangles. Data from shocks in which the maximum was observed between 50 and 100 km are shown as open diamonds. Data from shocks in which the maximum was observed between 100 and 200 km are shown as open squares with a diagonal slash. Data from shocks in which the maximum was observed between 200 and 500 km are shown as open diamonds with a diagonal slash. Data from shocks in which the maximum was observed between 500 and 1000 km are shown as open diamonds with a diagonal slash.



"The 1964 earthquake was taken into account when designing the Valdez Marine Terminal. However, if you look at a satellite map of Port Valdez, you can see why the risk for a tsunami-like event would be lower where our facilities are, due to the angle of an incoming wave, as well as the depth of the water in front of the terminal. Additionally, our tanks are several hundred feet above sea level."
 Kate Dugan, TAPS Spokesperson
 Left: caption: "A 2x6 plank driven through a ten-ply tire by the '64 Good Friday tsunami" 157



158

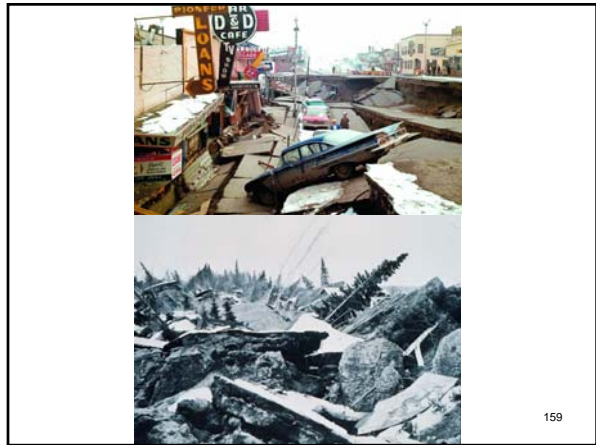

159

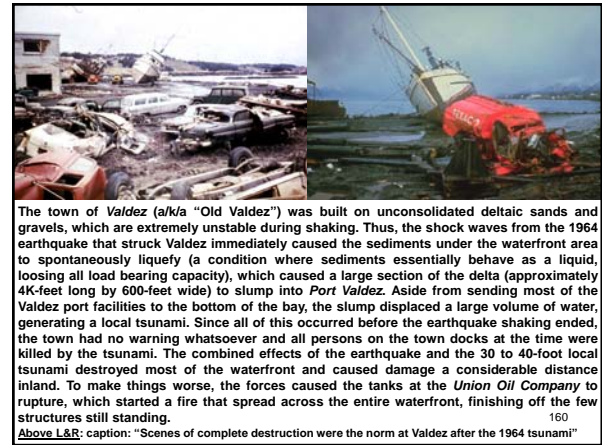

The town of Valdez (a/k/a "Old Valdez") was built on unconsolidated deltaic sands and gravels, which are extremely unstable during shaking. Thus, the shock waves from the 1964 earthquake that struck Valdez immediately caused the sediments under the waterfront area to spontaneously liquefy (a condition where sediments essentially behave as a liquid, losing all load bearing capacity), which caused a large section of the delta (approximately 4K-feet long by 600-feet wide) to slump into Port Valdez. Aside from sending most of the Valdez port facilities to the bottom of the bay, the slump displaced a large volume of water, generating a local tsunami. Since all of this occurred before the earthquake shaking ended, the town had no warning whatsoever and all persons on the town docks at the time were killed by the tsunami. The combined effects of the earthquake and the 30 to 40-foot local tsunami destroyed most of the waterfront and caused damage a considerable distance inland. To make things worse, the forces caused the tanks at the Union Oil Company to rupture, which started a fire that spread across the entire waterfront, finishing off the few structures still standing.
 Above L&R: caption: "Scenes of complete destruction were the norm at Valdez after the 1964 tsunami" 160



Above: the map above shows two different locations for Valdez. The first, Old Valdez (far right), represents the town's location before the 1964 tsunami and the second, New Valdez (center-right), its location after the 1964 Good Friday tsunami. Smaller waves from the main tectonic tsunami struck Valdez several hours after the local tsunami, but their effect was minimal (there was little left too destroy). In addition to ruining Old Valdez, the local tsunami affected other areas of Port Valdez as well. At Cliff Mine, the tsunami runup was 170-feet and at Shoup Bay, the runup was +100-feet (both far left). After suffering through the tsunami experience of 1964, the Town of Valdez was rebuilt at its present location, situated at a higher elevation and on more stable ground, to offer greater protection from tsunamis. 161

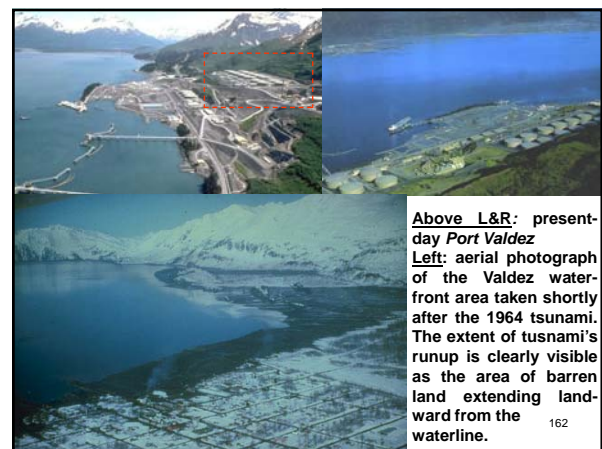

Above L&R: present-day Port Valdez
Left: aerial photograph of the Valdez waterfront area taken shortly after the 1964 tsunami. The extent of tsunami's runup is clearly visible as the area of barren land extending landward from the waterline. 162

"...In an attempt to limit the size of possible oil spills, TAPS engineers have included a system of check and block valves so no more than 64,000 barrels of oil are likely to escape from any point in the system..."

Popular Mechanics, January 1974

RE: TAPS has 177 block valves, of which 96 are remotely controlled gate valves and 81 are automatic check valves, the latter to prevent back flow in case of line-pressure loss. In 1997, the APSC conducted extensive risk-assessment to establish minimum acceptable performance standards for all mainline block valves. The threshold for repair is whether the amount of oil leaking through a valve seal is theoretically enough to add to the volume of oil that would spill from a 1-inch pipeline leak.

163

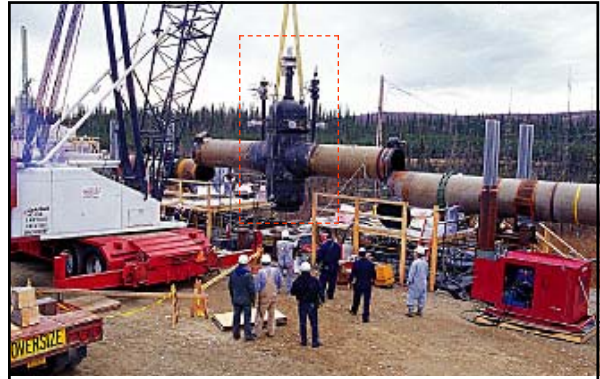

Above: caption: "A main line valve (RGV 80) is lifted from its site at MP 519 near Delta Junction, south of the midway point on the Trans-Alaska Pipeline, to be analyzed for sealing problems. Another valve from the Alyeska inventory replaced it in a 29-hour operation that shutdown the pipeline at the end of September 1998." 164

Avoid or Contain

165

"...In spite of elaborately detailed contingency plans to staunch and clean up oil spills, pipeline leaks could do serious damage to vegetation and streams, and destroy important fish spawning grounds hundreds of miles downstream. Lin's IPT system is designed to avoid or contain the various hazards..."

Popular Mechanics, January 1974

166

No Obstacle

167

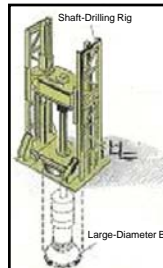

"...Permafrost is no obstacle to IPT construction because in its frozen state it provides solid, rock-like bearing. Fifty-foot pier holes would be sunk with rock-drilling rigs with 10-foot-diameter bits. When a hole is ready, the pier - a precast hollow concrete cylinder is lowered into place from a steel erection truss..."

Popular Mechanics, January 1974



Left T&B: caption: "Special drilling rigs such as that shown in the drawing (top) could be used to dig the holes required by the big piers. In soft ground, large-diameter holes can be drilled in a single operation, though this would not be the case in Alaska. Shaft shown in photograph (bottom) was cut with a 10-foot-diameter auger." 168

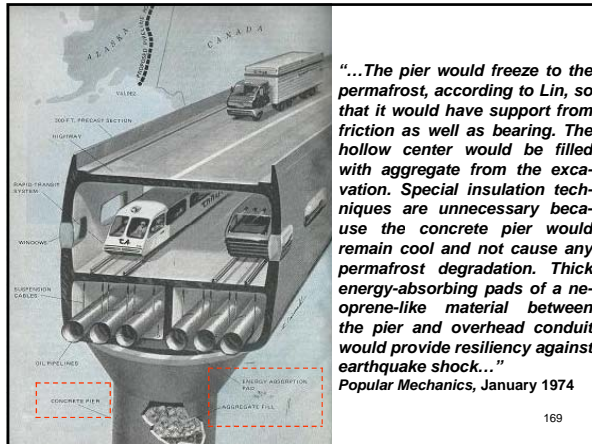

“...The pier would freeze to the permafrost, according to Lin, so that it would have support from friction as well as bearing. The hollow center would be filled with aggregate from the excavation. Special insulation techniques are unnecessary because the concrete pier would remain cool and not cause any permafrost degradation. Thick energy-absorbing pads of a neoprene-like material between the pier and overhead conduit would provide resiliency against earthquake shock...”

Popular Mechanics, January 1974

169

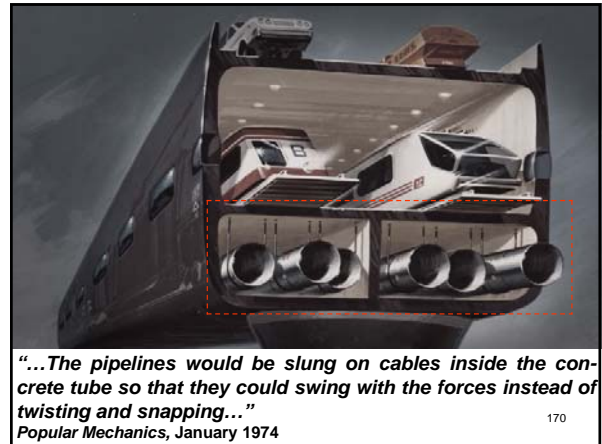

“...The pipelines would be slung on cables inside the concrete tube so that they could swing with the forces instead of twisting and snapping...”

Popular Mechanics, January 1974

170

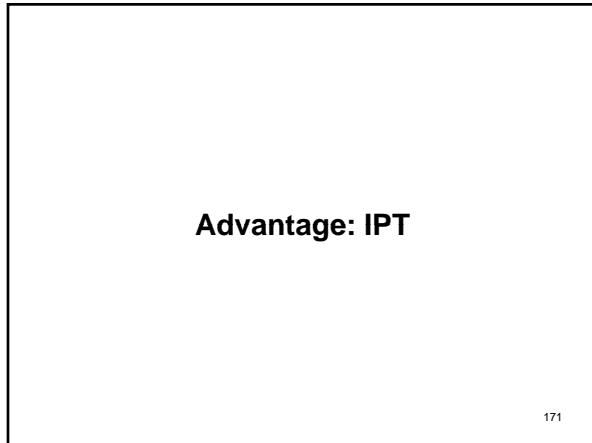

Advantage: IPT

171

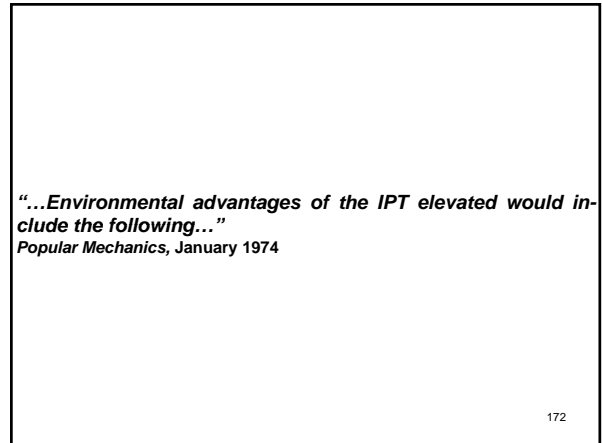

“...Environmental advantages of the IPT elevated would include the following...”

Popular Mechanics, January 1974

172

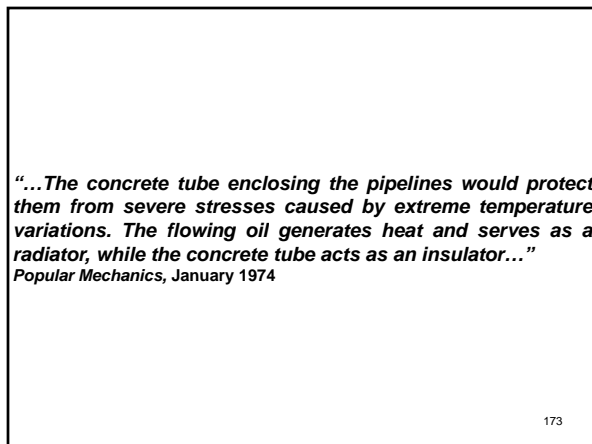

“...The concrete tube enclosing the pipelines would protect them from severe stresses caused by extreme temperature variations. The flowing oil generates heat and serves as a radiator, while the concrete tube acts as an insulator...”

Popular Mechanics, January 1974

173

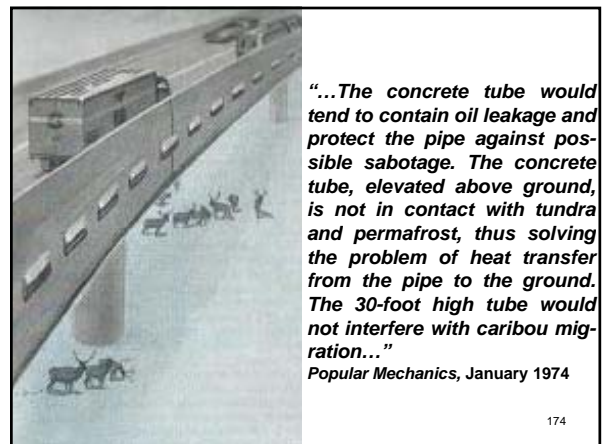

“...The concrete tube would tend to contain oil leakage and protect the pipe against possible sabotage. The concrete tube, elevated above ground, is not in contact with tundra and permafrost, thus solving the problem of heat transfer from the pipe to the ground. The 30-foot high tube would not interfere with caribou migration...”

Popular Mechanics, January 1974

174



“...The use of bridge-launching techniques minimizes access road construction to that necessary to reach production plant stations. These stations could be situated in areas picked to minimize adverse environmental effects. This contrasts with the 92-foot right-of-way TAPS needs for a permanent roadway and room for construction...”

Popular Mechanics, January 1974

Above: caption: “The bridge-launching method the inventor proposed for his IPT system is seen in operation during the construction of a river-spanning bridge in Italy”

175

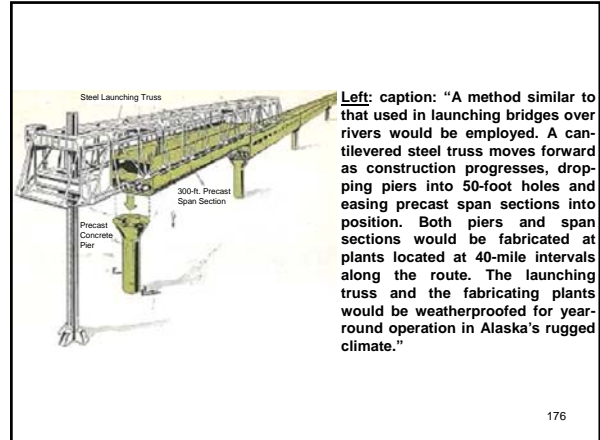

Left: caption: “A method similar to that used in launching bridges over rivers would be employed. A cantilevered steel truss moves forward as construction progresses, dropping piers into 50-foot holes and easing precast span sections into position. Both piers and span sections would be fabricated at plants located at 40-mile intervals along the route. The launching truss and the fabricating plants would be weatherproofed for year-round operation in Alaska’s rugged climate.”

176

“...By including all modes of transport, including passenger, freight, communication, power, oil, gas, water lines, a single artery would serve in place of the usual proliferation of pipes, lines and roads. The IPT tube is designed to accommodate future needs. Highway lanes, for example, could be changed to rapid transit...”

Popular Mechanics, January 1974

177

Maxi vs. Midi

178

“...One of the questions Lin faces in designing IPT is just how much capacity - how many pipelines and how much roadway should the tube provide for?...”

Popular Mechanics, January 1974

179



“...The ‘maxi’ version has a tube 40-feet wide and 33 in height. It’s designed to hold six four-foot pipelines. It includes four traffic lanes, with two lanes exposed on the top of the tube, and two lanes enclosed inside. The lanes within the tube would provide all-weather transportation. The maxi version would be sufficient for many decades to come. But higher initial investment costs and conservationist’s fears that it would overstimulate development have led Lin to concentrate on a lower-capacity ‘midi’ version...”

Popular Mechanics, January 1974

180

"Midi" Version

Rapid Transit System

Power Lines

Oil Pipelines

Communications cables

23 FT

30 FT

10 FT

Gas Line

"...The midi will still have space to contain six pipes, but only two transit lines are provided for, and these run on top of the concrete tube. Snow and ice removal would be necessary. At first these two lanes would be used for highway transportation, then could be converted to electrified rail..."

Popular Mechanics, January 1974

Left: caption: "Two levels of traffic would be accommodated in the 'Maxi' configuration of the Integrated Pipeline Transportation system. Top-level highway could be converted to a second rail system. More modest version of the IPT is shown in cross-section."

181

Speed and Economy

182

"...The speed and economy of constructing IPT would be greatly enhanced by modern mass-production techniques used in concrete plants to manufacture segmental-type bridge components. These fabricating and construction plants - at 40-mile intervals along the route - would be covered to enable year-round operation. Using aggregates quarried nearby, each plant would precast the piers and the 300-foot tubular sections. From these fabrication centers, the manufactured components would be moved over the section of the IPT bridgeway already constructed and placed on piers by the cantilevered launching truss..."

Popular Mechanics, January 1974

183

"...Lin's estimate for building nearly 800 miles of a midi-version IPT comes to \$6 billion. The current TAPS cost is put at about \$3.5 billion..."

Popular Mechanics, January 1974

RE: when all was said and done, TAPS cost \$7.7 billion to construct

184

Increasing Demand

185

"...The IPT with two pipelines is comparable in cost to two singly laid conventional pipelines. The TAPS pipeline is designed to carry a maximum of 2 million barrels of oil per day, one-tenth of the 20 million barrels consumed daily in the United States. By 1985 our oil use is expected to rise to 30 million barrels a day. This would undoubtedly create pressure for more pipelines to haul more oil from our arctic reserves..."

Popular Mechanics, January 1974

186

In the Long Run

187

"...This is all the more reason why the TAPS system should not be adopted, says Lin. 'If this outmoded proposal is carried out,' he warns, 'oil spill and other environmental degradation may stir up enough public opposition to prevent future needed pipelines. If the oil industry should win this battle, it will lose in the long run.'"
Popular Mechanics, January 1974

188

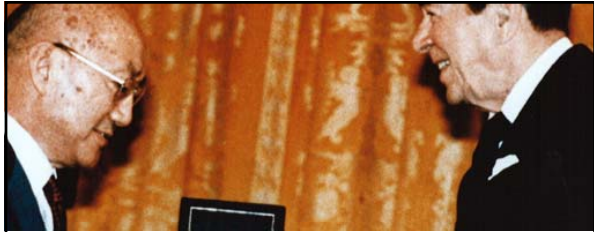

"You spend money on bombs, and in ten years they're out of date. You have to throw them away or destroy them. But you build bridges, they last forever."

Y.T. Lin

RE: Lin's response to a reporter's question in 1987. Y.T. Lin's list of awards included the *National Medal of Science*, which POTUS *Ronald Reagan* presented to him in 1986 (above) - an occasion where the accomplished engineer startled the president by handing him a design for a proposed "Intercontinental Peace Bridge" across the *Bering Strait*.

189

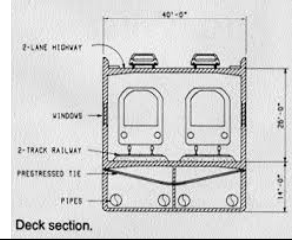

190



191

Part 4

Two If By Sea

192

Under the Midnight Lights

193

"Down in bow's empty blackness, the sound of the ship crashing through the ice was like a thousand workmen hammering on the hull. Suddenly I knew that one of those massive chunks, big as a freight car, was going to tear through the two-inch steel plating. Quickly, I climbed up the rusty hold ladder. Topside, under the midnight northern lights, I leaned into the frigid Arctic wind on a catwalk sticking out from the bow. The ship's searchlights reflected off the ice far, far into the distance. As the vessel plowed forward, giant cracks, like black lightning, jagged forward in thousand-foot splits. The prow pushed down slabs of ruptured ice nine feet thick. These broke into garage-size chunks that flopped over onto their backs in slow motion - green, blue - even pink..."

Popular Science, January 1970

RE: In 1969, four shipyards, an international team of maritime experts and three major oil companies pitted their considerable technical, creative and financial resources against the monolithic might of nature. Their goal: to take a tanker through the daunting, deadly Northwest Passage. The icebreaking tanker SS *Manhattan* was the Humble Oil Company's attempt to see if it might be profitable to move the newly discovered oil deposits on the North Slope of Alaska to the East Coast by plowing through the ice-clogged passage.

194



For five-hundred years, the Northwest Passage had tempted merchant adventurers with its promise of a seaway connecting the Atlantic and Pacific Ocean/s across the ice-choked top of North America. The first explorer to make it through did so in a three-year voyage in 1906. Though followed in succeeding decades by ice-breakers and nuclear submarines, turning the Passage into a commercial route remained only a dream.

Left: caption: "Gerard Mercator's late sixteenth-century map of the Arctic and surrounding lands records attempts by explorers Frobisher and Davis to find the Northwest Passage. It was believed an inland lake or rivers allowed passage across the American continent."

Right: "Satellite photo shows the Northwest Passage winding its way from the Atlantic through the Canadian Arctic's archipelagoes. The Northwest Passage remained un-navigable because of ice until recent thawing."

195

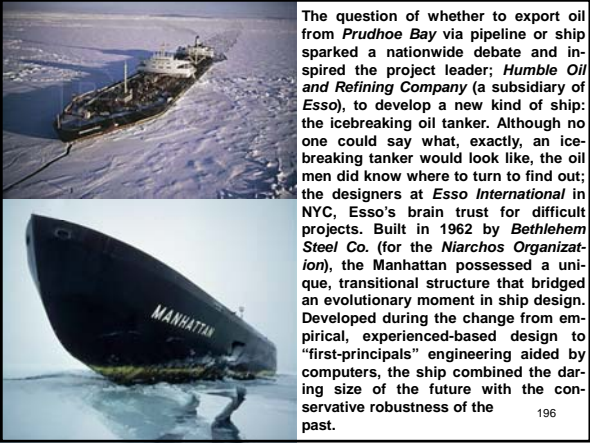

The question of whether to export oil from Prudhoe Bay via pipeline or ship sparked a nationwide debate and inspired the project leader; Humble Oil and Refining Company (a subsidiary of Esso), to develop a new kind of ship: the icebreaking oil tanker. Although no one could say what, exactly, an ice-breaking tanker would look like, the oil men did know where to turn to find out; the designers at Esso International in NYC, Esso's brain trust for difficult projects. Built in 1962 by Bethlehem Steel Co. (for the Niarchos Organization), the Manhattan possessed a unique, transitional structure that bridged an evolutionary moment in ship design. Developed during the change from empirical, experienced-based design to "first-principals" engineering aided by computers, the ship combined the daring size of the future with the conservative robustness of the past.

196



"When management asked us about icebreaking tankers, we answered that we can, presumably, build one and run an experiment. Three of us who had worked together at Bethlehem Steel knew the perfect vessel for the job: the SS Manhattan...The Manhattan was the only twin-screw tanker over 100,000 dwt in the world at the time. With 43,000 shaft hp it had considerably more horsepower per ton displacement than any other major merchant ship. Her short tank length gave a substantially more rigid structure than found in more modern designs, and her scantlings were so heavy - much more than one finds in tankers of similar size today - that the bottom plating, deck, and upper hull structures were of normalized, or heat-treated, steel, which by nature has very favorable low-temperature characteristics."

Bill Gray, Esso's Arctic Project Mgr.

197

North by Northwest

198



"...I was aboard the SS Manhattan, 500 miles north of the Arctic Circle, plowing a furrow through icy Melville Sound. The Manhattan is that tanker converted by Humble Oil and Refining Co. into a gargantuan icebreaking oil carrier. It was on its maiden voyage - one guaranteed to make history. We were trying to break through the Northwest Passage..."

Popular Science, January 1970

Above: the largest ship ever to fly an American flag, the SS Manhattan busted its way north through heavy ice in the summer of 1969. If the Manhattan could prove its worth, Humble Oil envisioned the recently discovered North Slope oil moving away from Prudhoe Bay in supertankers that would be even larger.

199

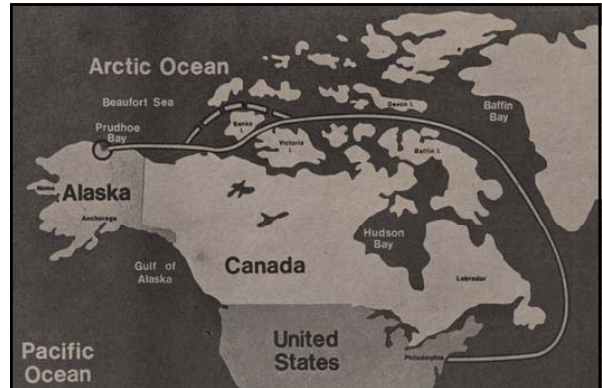

Above: caption: "The 4,500-mile voyage of the Manhattan from Philadelphia to Prudhoe Bay is expected to take one month"

200

"...The crew of 54, plus 72 others, left Chester, Pa., on August 24 for a 5,628-mile journey never before attempted by a commercial vessel. If anything could make it, the Manhattan would. The ship is as long as three football fields, or the Empire State Building on its side, and big enough to carry two cans of beer for every adult American. The Manhattan weighs 150,000 tons - biggest ship in the U.S. merchant fleet - and her turbines push with 43,000 shaft hp..."

Popular Science, January 1970

RE: among others, Humble Oil and Refining Co. recruited scientists from the Geophysical Institute of the University of Alaska Fairbanks to measure the properties of sea ice the SS Manhattan crushed during the voyage.

201



Above: caption: "NORTHWEST PASSAGE BOUND - Even before being modified for the Northwest Passage test, the S.S. Manhattan was the largest merchant ship ever to fly the American flag, the largest commercial ship ever constructed in the U.S., and one of the largest commercial vessels in the world. Standing on her bow, the 1,005 foot-long Manhattan would almost match the Empire State Building in height. In addition to size, the Manhattan is highly maneuverable and extra powerful. Its speed fully loaded is 17 1/2 knots."

202

"At a certain speed there was a maddening wah-wah-wah-wah. We'd say, 'Go faster or go slower'"

Merritt Helfferich

RE: joining the SS Manhattan at Halifax, Nova Scotia, Helfferich (then 31yo) of the Geophysical Institute of the University of Alaska Fairbanks, joined the team of engineers and scientists when the ship's launch was delayed and academics among the make-shift team needed to return home to teach their fall classes. When the sea ice bashed a Doppler speed-tracking system (one of the few setbacks for the ice-strengthened tanker) Helfferich and other scientists on-board helped track the velocity of the Manhattan by throwing a block of wood to the ice and counting the seconds it took for the ship to pass the block. His main duties were to helicopter-out to ice in the Manhattan's path and test its thickness, saltiness and other features. He, as well as the others on the scientific team, had to take a vow of secrecy lest other oil companies (not participating in the experimental voyage) benefit from the data obtained.

203



204



Above: caption: "Artist's conception of S.S. Manhattan on maiden voyage to open commercially the Northwest Passage. The world's first tanker-icebreaker - was specially outfitted and manned for this epic journey by Humble Oil & Refining Co. and the cooperation of the U.S. Coast Guard and the Canadian Dept. of Transport." 205

A Cool \$40 Million

206



"...The journey to Alaska's north coast and back is costing Humble a cool \$40 million. But the prize is worth it: oil, in quantities that compare with the output of the fields of Texas or the Middle East..."
Popular Science, January 1970
 RE: after leaving Chester, Pa., on August 24th 1969 and reaching Prudhoe Bay and then Point Barrow by September 14th 1969, the SS Manhattan returned through the Northwest Passage to New York by November 12th 1969. Despite an iceberg puncturing part of the hull and being turned back by congested ice floes, the voyage of the SS Manhattan proved the possibility of moving oil year-round through the Northwest Passage.
Above: caption: "Map of the route followed by the SS Manhattan" 207

"...The oil is on Alaska's hostile northern-most edge. The big problem is how to get it out. One possibility: pipelines across Alaska or Canada. Another: giant submarine tankers traveling under the ice. But the Alaskan pipeline would carry oil only to Alaska's south coast. A trans-Canadian line probably is too expensive. And designs for oil-toting subs are only now appearing on the drawing boards..."
Popular Science, January 1970
 RE: in the late 1960s, Oil Industry executives were busy wondering how the rich deposits of crude oil in Prudhoe Bay could find its way to market. Thus, in 1968 a consortium of oil companies gambled that a *Trans-Alaska Pipeline* (TAP) would prove more profitable, and practical, than ice-breaking tankers. Before they were even issued permits for TAP, the consortium purchased 800 miles of fine-grain steel pipe from Japanese manufacturers. The voyage of the SS Manhattan would determine if their gamble could/would pay dividends. 208

The Making of an Ice-Slicer

209

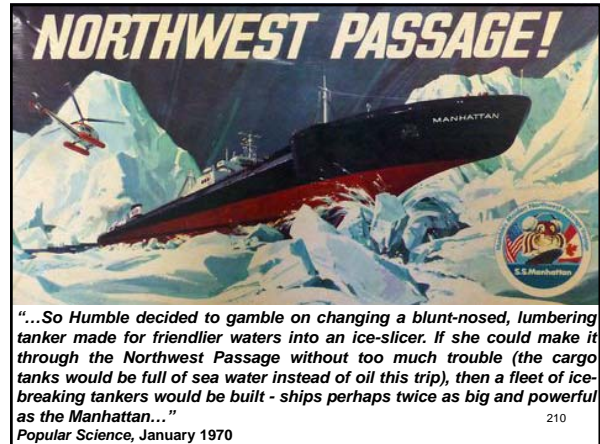

"...So Humble decided to gamble on changing a blunt-nosed, lumbering tanker made for friendlier waters into an ice-slicer. If she could make it through the Northwest Passage without too much trouble (the cargo tanks would be full of sea water instead of oil this trip), then a fleet of ice-breaking tankers would be built - ships perhaps twice as big and powerful as the Manhattan..."
Popular Science, January 1970 210

In December 1968, a team from *Wartsila* approached *Esso* and offered to share everything they knew about ice-breaking. It was an unusual offer since *Wartsila* was the world leader in icebreaking technology and had built 60% of the of the world's icebreaking fleet. When asked why, they answered, "Icebreaking is one of our main business lines. You don't know anything about it, and it'll give icebreaking a bad name if you mess it up." They joined the project and were with it from beginning to end. The experiment lasted twenty months from start to finish. *Wartsila* advised the project every step of the way; from vessel conversion to testing and finally to the modeling and design of future ships for *Northwest Passage* service.

211

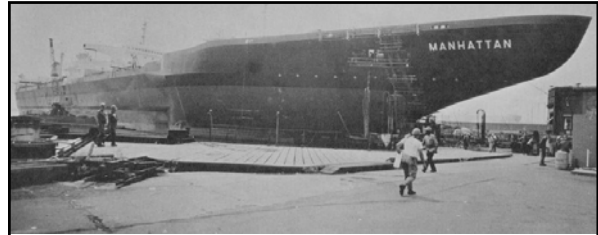

"...This ship was originally built in 1962. Her power plant was designed for a vessel half again larger, so for conventional use she was overpowered. For *Humble's Arctic gamble*, though, she was the best thing around. But she needed a major conversion job to tackle those frozen waters. They sliced off the old prow and built a new one. It was not only an odd design for a tanker, but new for an icebreaker, too..."

Popular Science, January 1970

Above: caption: "SS Manhattan (1962)"

212

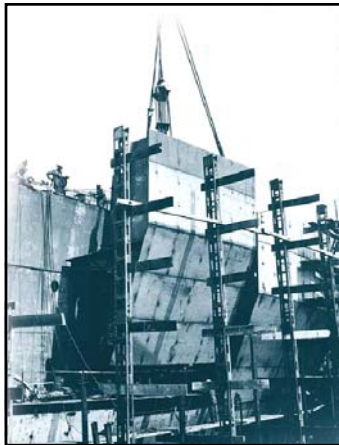

The *SS Manhattan* retrofit project took everyone involved into new, uncharted territory; shipyard, scientist and technical expert alike. When the project got the green light, very little was actually known about the extent of the work needed to ready the ship for Arctic service. Only one yard: *Sun Shipbuilding* in Chester, Pa., was willing to take on the task (which had been tendered only as: "extensive modification," requiring: "strengthening the hull and installing an ice-breaking bow and propellers and rudder protection." In fact ultimately, over 9K-tons of steel would be added to the ship.

213



"...An icebreaker doesn't cut through the ice, but actually breaks it - either up or down. An upward breaking or *Alex-bow* prow flips ice over like a snowplow. The *Manhattan* uses a 725-ton downward breaking prow with two new features. Instead of just the conventional 30-degree nose tilt, the bow pushes into the ice at 18 degrees, then increases to the standard 30 degrees as the ice crunches underneath. Model tests indicated that the new nose would increase icebreaking capability by as much as 40 to 60 percent (rough measurements aboard ship seem to verify it). The other new feature of the prow is its beam. It is wider than the ship - extends eight feet farther out on either side. This reduces hull friction by allowing open water between ice and hull..."

Popular Science, January 1970

Above: the *SS Manhattan* was built in Bethlehem Steels' shipyard in Quincy, Mass. In addition to its size, the *Manhattan* was highly maneuverable due to twin five-bladed propellers and twin rudders.

214



The *SS Manhattan* arrived at *Sun Shipbuilding* in January 1969, leaving in August as the most heavily armored merchant ship in history. At its height, the project occupied over 90% of *Sun's* 5,500-man workforce and 100% of its production capacity. In fact, at one point, *Esso* paid *Sun* to suspend work on two new buildings while it finished the *Manhattan*. Even so, the job was so big that no single shipyard could finish it within the required time frame and, at *Sun's* suggestion, the project was divided among four shipyards. The 493-foot aft section stayed at *Sun* for modification. *Newport News* took the 122-foot forward section and Number One cargo tank. The 264-foot midbody went to *Alabama Dry Dock* at Mobile. The new icebreaking bow was to be built in two sections, the 56-foot after-section at *Sun* and the 69-foot forward section at *Bath Iron Works* in Maine. In each yard, work was carefully scrutinized. Transverse bulkheads were strengthened by the addition of doublers (installed in the same way as welded connections for horizontal girders) while heavy I-beams were placed at every web frame across the width of the ship. In the forward section, additional strengthening was provided by transversely-framed plated sponsons of high-strength steel placed over the existing side shell. A 9-foot wide, sloping steel belt was added to the ship's sides to increase strength and deflect the deadly pressure ice typical of the region.

215

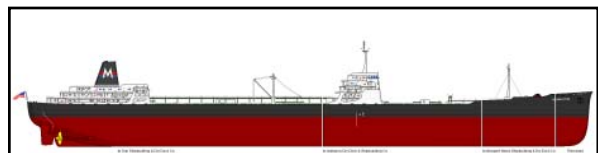

Above: to speed the conversion to an icebreaking tanker, the ship was dry docked at *Sun Shipbuilding and Dry Dock Company* and cut into four pieces. The 65-foot forward bow was stored at *Sun*, to be replaced by a new 125-foot icebreaking bow which was built in two sections. The forward section was built by *Bath Iron Works* and the after section was built by *Sun*. The forward section, including the No.1 cargo tank, was towed to *Newport News Shipbuilding and Dry Dock Company* where it was fitted with a heavy 1½" thick ice-belt to protect the sides of the ship from large floes of ice. The mid-ship section, which included the bridge, was towed to *Alabama Dry Dock and Shipbuilding Company* where an ice belt, made of steel, was also fitted. The stern section remained at *Sun* to be strengthened internally. While the hull work was being carried on, *Sun Ship* workers were installing additional quarters, laboratories and electronic gear.

216

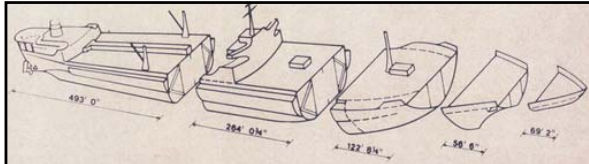

At the meeting point where two floes crash together, pressure ice forms rubble that has been known to climb up a ship's side, tumble onto the deck, and force the ship under. The ice belt did in fact help save the vessel on the second voyage, when the sloping sides caused the ice boulders to tumble back and away onto the floe. Other modifications included: adding a helideck; renewing the shafting with higher-strength materials; attaching a shearing coupling in the shafting to protect the low-pressure turbine rotor against the shock of ice loads; installing underwater rudder guards and higher-strength propellers; building a double hull for the machinery and steering gear rooms; reinforcing all machinery for stability and installing a special "liquid-phase" heating system that circulated heated oil to warm the deck machinery. Experience proved every modification necessary.
Above: caption: "S.S. Manhattan's segmentation and Parceling to Four Different Shipyards to Speed Construction." The segmentation of the Manhattan speeded the conversion. The 69-ft 2-in bow was built by Bath Iron Works. The 56-ft 6-in bow section was built at Sun Ship. The 122-ft 8¼-in forward section was converted by Newport News Ship and the 264-ft midsection was altered by Alabama Dry Dock. The stern remained at Sun Ship." 217



The most distinctive aspect of the SS Manhattan retrofit was the new bow. A design never before seen, it still influences icebreaker design. Previously, all icebreaker bows had a straight slope of about 30 to 40 degrees off the horizontal. The new bow, designed by Commander Rod White of the U.S. Coast Guard, was completely different. Its fore part was sloped at 18-degrees, curving gently down to the bottom, where it was plumb. Another lasting innovation of the Manhattan was the forward shoulder; the place where the bow section met the parallel body of the ship. It was made several feet wider than the hull in order to cut a wide swath through the ice and reduce friction on the vessel (when adopted for later-generation icebreakers, the feature was called a "reamer.") This wrap-around reinforcement to the bow, though only 123-feet in length, took nearly 3K-tons of steel. 218

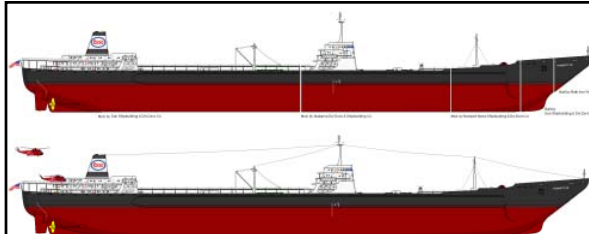

Despite 9,200-tons of added steel, an increase in length from 940 to 1,005-feet, added dead-weight of 10K-tons, a widening of 23-feet and the angular belt on it sides changing the midbody cross-section, the Manhattan lost only about a quarter-knot in service speed. The shipyard bill was \$28 million (at a time when a standard 250K-dwt tanker built in Europe cost about \$20 million). A further \$28 million went to the rest of the experiment's costs (including about \$10 million paid to the owners so that the ship didn't have to be un-converted). Arco and British Petroleum kicked in a token \$2 million each, meaning Esso bore the lion's share (\$54 million) of the cost.
Above L&R: caption: "When the hull sections were returned, Sun rejoined them, sealed off most of the cargo tanks (used for ballast) and put the ship through river trials" 219



Above L&R: caption: "S.S. Manhattan mid-body being towed thru the C&D canal 1969"
Left: caption: "Protection from ice being installed on rudders & propellers" 220

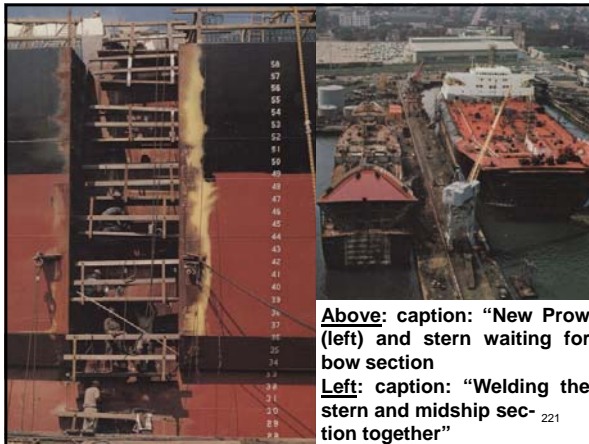

Above: caption: "New Prow (left) and stern waiting for bow section"
Left: caption: "Welding the stern and midship section together" 221



Top Left: caption: "Bow Section built and launched on a new section of Dry Dock No. 3"
Top Right: caption: "Bow being moved toward midship section Dry Dock No. 3"
Left: caption: "On Dry Dock No. 3 with new bow section attached" 222



Top Left: caption: "At Pier 4 waiting for Prow to be installed"

Top Right: caption: "Prow being guided into position off of Pier 1"

Left: caption: "Prow installed"

223



224

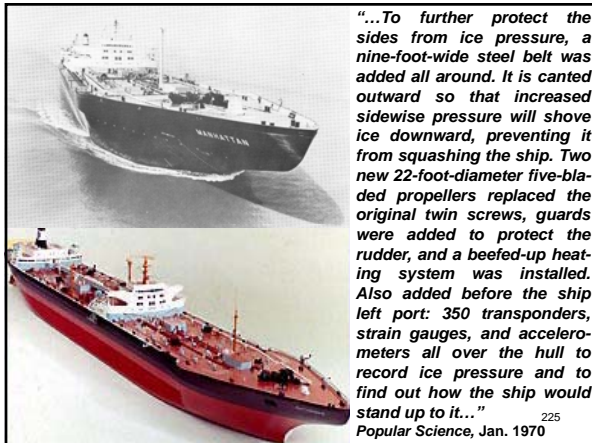

"...To further protect the sides from ice pressure, a nine-foot-wide steel belt was added all around. It is canted outward so that increased sidewise pressure will shove ice downward, preventing it from squashing the ship. Two new 22-foot-diameter five-bladed propellers replaced the original twin screws, guards were added to protect the rudder, and a beefed-up heating system was installed. Also added before the ship left port: 350 transponders, strain gauges, and accelerometers all over the hull to record ice pressure and to find out how the ship would stand up to it..."

225

Popular Science, Jan. 1970

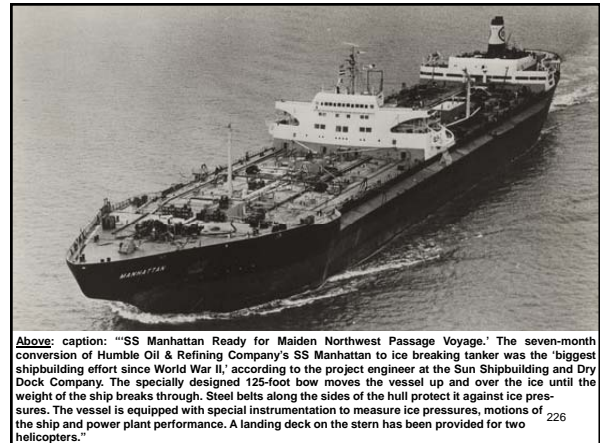

Above: caption: "SS Manhattan Ready for Maiden Northwest Passage Voyage." The seven-month conversion of Humble Oil & Refining Company's SS Manhattan to ice breaking tanker was the 'biggest shipbuilding effort since World War II,' according to the project engineer at the Sun Shipbuilding and Dry Dock Company. The specially designed 125-foot bow moves the vessel up and over the ice until the weight of the ship breaks through. Steel belts along the sides of the hull protect it against ice pressures. The vessel is equipped with special instrumentation to measure ice pressures, motions of the ship and power plant performance. A landing deck on the stern has been provided for two helicopters."

226



227

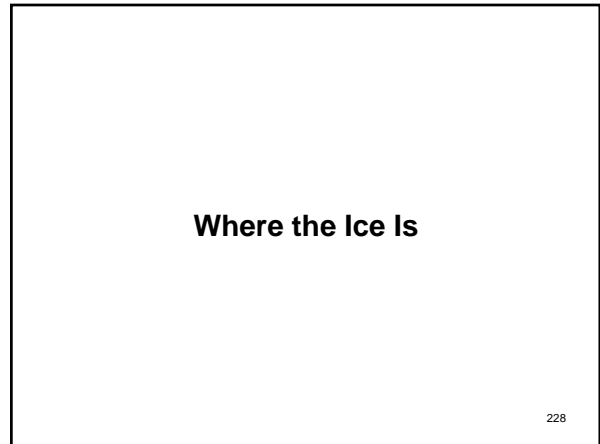

Where the Ice Is

228



"...Now, out in Viscount Melville Sound, the ship was behaving perfectly, battering through nine-foot-thick ice at a steady six knots (normal cruising speed is 16.5 knots). An ordinary icebreaker rises and falls with a rolling motion as it slides up on the ice and crashes down through it. But the Manhattan is so massive that it plows straight ahead..."
 Popular Science, January 1970 229

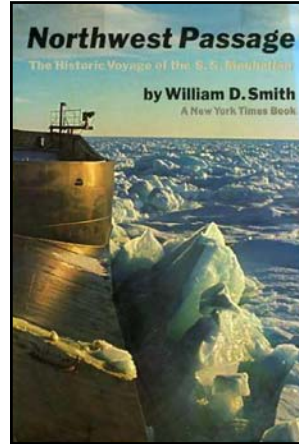

The SS Manhattan's first trip gave her a place in exploration history. As much publicity event as discovery mission, the late summer voyage took 126 people on a thrilling 4,400-mile journey into one of the last frontiers. The adventure was closely followed on the front pages of every major newspaper, riveting readers with images of ambitious man against inscrutable nature. It even made for a best-selling book, as a gasping world learned the particulars of Arctic ice. 230

"...Until this point in the voyage, most of the ice had been only a year or so old, and new ice is relatively soft. Now though - on the 17th day out - a choice had to be made. Smack in the ship's path was Bank's Island, some 200 miles across. The tougher route was north of it, through M'Clure Strait into the Beaufort Sea, then southeast to Alaska's northern coast. That way was the polar cap - old ice, thick, tough, treacherous, including broken pieces of glaciers trapped in the pack for perhaps a century. Worse yet, for the past week winds had been blowing the pack into M'Clure Strait, compacting and compressing it, forming pressure ridges 50 feet thick..."
 Popular Science, January 1970

RE: first-year ice contains salt, is white in color and somewhat flexible. If it survives summer, it re-freezes in winter, losing salt and becoming more like freshwater ice; thicker and stronger with a greenish tint. Multi-year ice has a bluish hue and a vicious hardness. Polar pack ice can exceed 3-meters thick and roams about in vast floating plains miles across. Crashing into each other, the floes form huge rubble hills and undersea ridges that can reach 30-meters deep.

231



232



Above: caption: "Das Eismeer (The Sea of Ice), 1823-1824, a painting by Caspar David Friedrich, inspired by William Edward Parry's account from the 1819-1820 expedition" 233

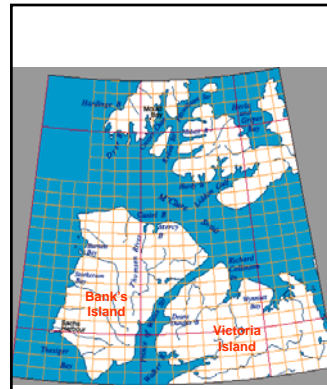

"...The southern route's ice, although thick, was new and soft. The smart thing, the economical thing, would be to head south. 'But this is a research trip,' said Captain Roger Steward as he checked ice reports. 'We're trying to find out what she can do. And that,' he said, pointing to a chart, 'is where the ice is.' The decision: Northeast into the polar cap. We would start in the morning..."
 Popular Science, January 1970
 Left: caption: "Bank's Island, Northwest Territories - Topographical Map"

234

The Older, the Colder

235

"...Next morning, as the ship cautiously nosed into M'Clure Strait, Captain Steward set into action an involve survey system. Far ahead of the ship, 3,000 feet up, a Canadian DC-4 flew the route. Then it dropped exposed photo film onto the ice. The ship's helicopter picked it up and brought it aboard to be developed. Two main aerial survey devices were used: a laser unit and an infrared camera. The laser, aimed straight down, measured the profile or height of the ice to within a few inches. The infrared photos measured the amount of heat in the ice; the older the ice, the colder it is. Together, these readings indicated toughness..."

Popular Science, January 1970

236

Never Before Obtainable

237



"...Meanwhile, a sophisticated navigation system was keeping track of the ship's speed and position in a region notorious for indistinct coastlines, overcast skies, useless compasses, and inaccurate charts. We use a method that 'produces navigational accuracies never before obtainable,' said Dr. Charles Baker, the Humble Oil scientist who developed it..."

Popular Science, January 1970

238



Above: caption: "Radio communications are checked in Philadelphia prior to sailing of the SS Manhattan. They were described by Humble Oil & Refining Company representatives as being equal to the most advanced military and commercial maritime systems in the world today. At least three major systems aboard the history-making tanker are utilizing technical advances which have been made in the past two years."

239

"...Manhattan's system combines the output of a Marquart doppler sonar unit with that of a satellite receiver. The sonar continuously bounces high-frequency sound signals off the bottom and flashes the ship's speed (to within one-tenth of a knot) and position (to within 500 feet) on a screen. The satellite radio receiver picks up position signals every 20 minutes from one of the four U.S. polar-orbiting navigation satellites. They're a double-check on the sonar positions. Speed and position readouts were duplicated on a TV-like screen on the bridge..."

Popular Science, January 1970

240



Left: caption: "A technician checks some of the navigational equipment that will guide the SS Manhattan on its Northwest Passage voyage. Among the vast array of sophisticated equipment used in navigation will be special-purpose earth satellites placed in polar orbit under the U.S. Navy Navigation Satellite System program. Impulses from these satellites linked with those from sonar, accelerometer and gyro signals comprise the integrated system that will guide the ship." ²⁴¹

Johnny Mack

242



"...Meanwhile, a mile astern, the pudgy Canadian icebreaker John A. MacDonal followed in the Manhattan's wake like a cub trailing its mother. Unlike the Manhattan, 'Johnny Mack' shuddered and swayed and bumped and crunched just as you'd expect an icebreaker to do. She'll strike a 10-foot hunk of ice 50 feet across, rise up as though on an escalator, balance momentarily at the peak, then slide sideways with a sickening roll, and charge on..."

Popular Science, January 1970
Top: caption: "S.S. Manhattan and Canadian Ice Breaker John MacDonal"
Bottom: caption: "CCGS John A. MacDonal" ²⁴³

In Harm's Way

244



"...The big test lay just ahead. And the going was getting rough. Halfway through M'Clure Strait the mammoth ship slowed, sped up, slowed again. Then with a shudder it stopped, nose rammed against a pressure ridge 55 ft. thick. A picture of the hull being ripped apart crossed my mind..." ²⁴⁵
Popular Science, January 1970

"...We bore down on a massive sheet of ice sixty feet thick and a mile across. The captain called for ten knots. The armored bow struck, and a plume of salt spray shot sixty feet into the air. Chunks of ice as big as bulls' heads soared in wide arcs like mortar shells. There was a deafening explosion as the great floe shattered; blocks the size of bungalows turned over and scraped along the ship with agonizing shrieks. Incredibly, the Manhattan trembled even less than a city sidewalk when a loaded truck passes..."

RE: excerpt from the account of *National Geographic* magazine's reporter aboard the SS *Manhattan*. Although half the voyage was through open water, most of the other half was spent breaking "rotten summer ice." However, there were enough moments of real difficulty for the ship to gather useful data.

246



"...Captain Steward, who was skippering an icebreaker for the first time, gave the order to go astern. The giant hesitated, then with immense labor eased her bulk backward - much to everyone's relief. Backing power is only about 60 percent of ahead power. She backed a thousand feet, then stopped. Ice floes had moved into her wake. Forward again. She struck the ridge at only two knots - there wasn't enough distance to build up more speed - but amazingly the ridge split. She was through..."

Popular Science, January 1970

RE: to pass through heavy ice, an icebreaker rams, rides up and breaks through as the ship presses down (above L&R). Especially thick ice can stop a ship entirely, giving it two choices: heel and rock until working free, then back up, build up speed and try again or, like its wooden-hulled ancestors did; wait until the wind changes and opens a space in the pack. 247

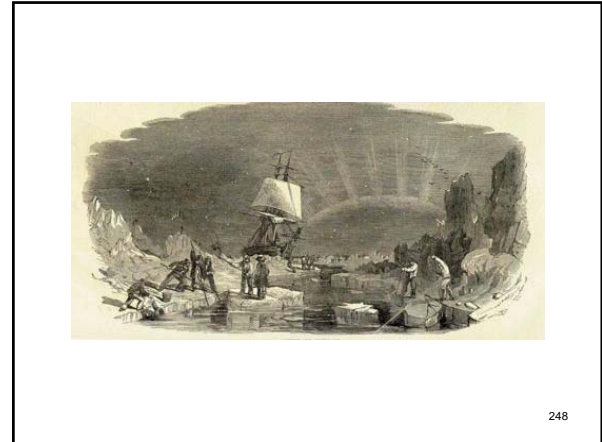

248

Between an Iceberg and a Hard Place

249

"...Suddenly she stopped again, this time halted by a steel-hard polar ice 14 feet thick with a pressure ridge rising 20 feet above the surface. How far did it go? Guesses ranged from 30 to 50 feet. Again, the ship's momentum had not been great enough...The wind continued to press the ice against the Manhattan's sides. And there was no place for the slabs to go. They broke, then compressed against her. She backed again, about half her length, and slammed forward once more. For 12 hours she hacked and rammed, her turbines straining to drive her through..."

Popular Science, January 1970

250

Almost Always Counts

251

"...Finally, up on the bridge, Thomas C. Pullen, A Canadian expert in icebreaking and himself a ship's captain, radioed to the Johnny Mack: 'Would you mind nibbling at our quarters?' The little ship battered her way up alongside the huge Manhattan, breaking the ice there and easing the pressure on her sides. Then she re-broke the path astern of the ship. The Manhattan backed-up, got a running start, and crashed through. Later, divers found that one of Johnny Mack's propellers had been seriously damaged by her effort. Which means that the ships came darn close to getting stuck - maybe frozen there until summer..."

Popular Science, January 1970

252

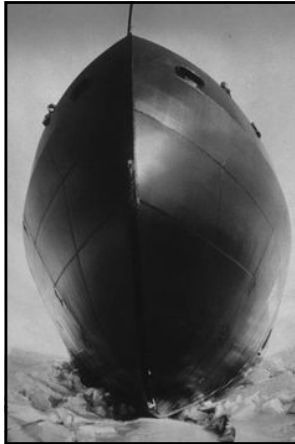

"...We just don't have the power we need,' said expedition head Stanley Haas. Dutch ice-expert Bram Mookhoek commented: 'With much more power, along with certain hull modifications to reduce friction, I believe the ship could easily go anywhere in the world.' But on that first trip the power plant wasn't quite robust enough. Six times the ship got stuck, and each time the little Canadian icebreaker came to her rescue (later it was decided that when more Manhattan's are built, they will have considerably more power, and that icebreaker support - probably standby ships along the route - will be necessary)..."

Popular Science, January 1970
 Left: caption: "The S.S. Manhattan breaks through Arctic ice floes during her historic voyage" 253



"We couldn't have made the passage without the help of our icebreaker escorts, the U.S. Coast Guard's 'Wind' class vessels and particularly the Canadian John A. MacDonald. At times, when the ship was stuck in pressure ice, the only way to get out was to have them cut a path around her."

Bill Gray, Esso's Arctic Project Mgr.
 Left: caption: "Northwind, ca. 1955, a good example of the Wind class before they were painted red and had their teeth removed"

Retreat, Hell!

"Retreat, hell! We're not retreating, we're just advancing in a different direction!"
 General Oliver Smith, USMC
 RE: in November 1950, eight Chinese divisions engaged the 1st Marine Division and other U.N. forces. Surrounded at the Chosin Reservoir, Smith directed the breakout and subsequent 70-mile march to the seaport of Hungnam.

"...Finally, two days later, red-eyed and weary, Captain Steward decided to turn the ship around and head southwest. So, again with Johnny Mack's help, the mammoth Manhattan made a two-mile-wide U-turn and backtracked out of M'Clure Sound. Now, if she could only ram through the much narrower Prince of Wales Strait, she could sail the rest of the way through new, softer ice and open water along the Alaskan coast. Just as the ship had success in sight, an enormous pressure ridge - a 40-foot-thick slab surrounded by iron-tough ice a dozen feet thick - loomed ahead. And for the last time the ship shuddered to a stop, not quite able to push through..."

Popular Science, January 1970

Breakout



“...Then T. Darrah Moore, a company representative, came up with the idea of temporarily shutting off all auxiliary machinery on board. This, he figured would put all the ship’s power on the two propeller shafts. The ship backed half its length. Then the crew turned off non-essential lights, heating units, water-distillation plants. The extra steam to the turbines, they calculated later, added about 7,000 hp to the normal 43,000. It worked. She pushed through the last ice ridge and 10 minutes later broke into open water...”
Popular Science, January 1970

259

“...The Northwest Passage’s defenses - 800 miles of frozen sea - had been breached. Captain Steward celebrated by ordering champagne for all hands. The Manhattan put into Pt. Barrow on her 28th day out, then headed back over the same route. Four weeks of tests in Melville sound followed, and seven weeks later the conqueror of the Northwest Passage docked in New York.”
Popular Science, January 1970

RE: the SS Manhattan returned to NYC on October 30th 1969, carrying only a symbolic barrel of oil. She retained her distinct prow and resumed regular tanker service until 1987. On July 15th 1987, she was driven aground at Yosu, South Korea during the passage of typhoon Thelma. She was re-floated on July 27th 1987 and sold to Hong Kong interests then re-sold to Chinese breakers. She left Yosu in tow on September 1st 1987 and arrived at the breakers yard on September 6th 1987. The voyage of the SS Manhattan, though plagued with difficulties, proved the possibility of moving oil year-round through the Northwest Passage.

260

“The idea of using an icebreaking tanker to ship crude oil from Alaska’s North Slope to the ‘Lower 48’ has been ‘suspended’ by the Humble Oil & Refining Co. In making the announcement, company officials said that a proposed trans-Alaska pipeline appears to be a more commercially feasible way to move the oil. Transportation has been the main stumbling block to the exploitation of the Alaska oil discovery made back in ‘68...”
Popular Mechanics, January 1971

261



“...In 1969, the Manhattan, a 115,000-ton, icebreaking tanker, made an historic voyage through the Northwest Passage to the North Slope. Though battered, the big ship returned to an East Coast port with a symbolic barrel of oil. The experiment cost about \$30 million.”
Popular Mechanics, January 1971
 Left: official maiden voyage patch

262

Second Voyage

263



At Bill Gray’s urging, Esso sent the Manhattan on a second voyage the following April, to test itself against the severe Arctic winter ice. In fact, the multi-year pack was ice so tough the ship couldn’t even enter the Northwest Passage. Instead, it went to Pond Inlet near the top of Baffin Island, where the investigators conducted their ice-breaking tests, gathering valuable data. The ship was heavily instrumented, with strain gauges throughout the hull and the most modern electronics available (housed in a 50-ft container on deck). Afterwards, a model of the ship was built and tested in Wartsila’s new Ice Model Basin (example above). Built specifically to support the Manhattan Experiment, the basin opened the door for ice technology know-how exchange between Soviet and Finnish scientists (a lesser-known part of the voyage of the Manhattan’s legacy). Voyage data was compared with model tests and calculations to calibrate the basin and its test results, with the information serving as the design basis for Wartsila to design the icebreaking-class tankers of the future.

264

"As things worked out, the pipeline has proven to be a better solution economically, but not by much. Tankers would require such high power that they would have burned two to three percent of their cargo as fuel on the voyage; the pipeline consumes virtually none of its cargo, which becomes a big difference as the price of oil rises...The best thing about the experiment was that we showed conclusively that it would be technically and economically feasible to do year-round marine transportation in tankers through the Northwest Passage. Commentators at the time, and even today, consider the experiment a failure. But it wasn't a failure at all. The Manhattan was not intended to transport oil from the North Slope, nor to serve as a prototype tanker for that service. The whole experiment was one great, big model test. We needed to study the behavior of a ship that was perhaps 15 times bigger than any icebreaker ever built. And, as a big model test, it was a success. She did exactly what she was supposed to do."

Bill Gray, Esso's Arctic Project Manager

RE: the reason the fleet Arctic tankers were never built was not experimental failure but, rather, the project's sponsors saw the *Manhattan Experiment* as a backup plan only, to be activated in the event TAPS was not approved/built. From an energy efficiency perspective, shipping by tanker is more efficient than TAPS. Transporting oil over the ocean has an estimated energy intensity between 60 and 100 BTU/ton-m, as compared to TAPS' 280 BTU/ton-m.

265



266

Part 5

Three If By Air

267

The Brute Lifter

268

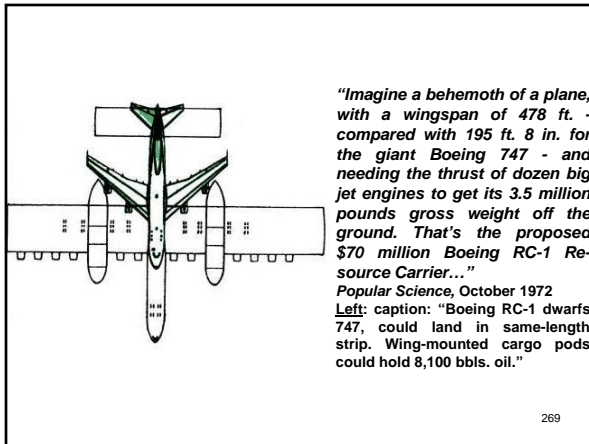

"Imagine a behemoth of a plane, with a wingspan of 478 ft. - compared with 195 ft. 8 in. for the giant Boeing 747 - and needing the thrust of dozen big jet engines to get its 3.5 million pounds gross weight off the ground. That's the proposed \$70 million Boeing RC-1 Resource Carrier..."

Popular Science, October 1972

Left: caption: "Boeing RC-1 dwarfs 747, could land in same-length strip. Wing-mounted cargo pods could hold 8,100 bbls. oil."

269

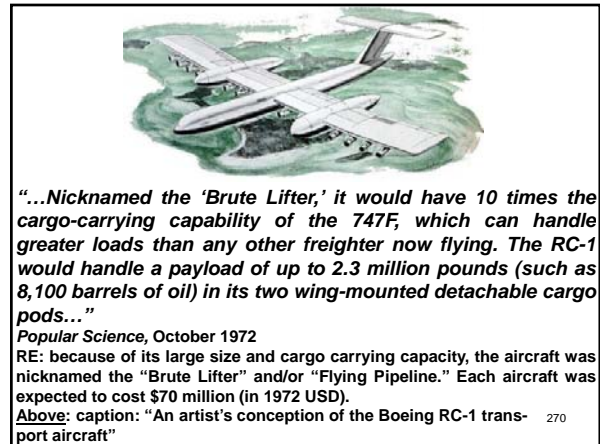

"...Nicknamed the 'Brute Lifter,' it would have 10 times the cargo-carrying capability of the 747F, which can handle greater loads than any other freighter now flying. The RC-1 would handle a payload of up to 2.3 million pounds (such as 8,100 barrels of oil) in its two wing-mounted detachable cargo pods..."

Popular Science, October 1972

RE: because of its large size and cargo carrying capacity, the aircraft was nicknamed the "Brute Lifter" and/or "Flying Pipeline." Each aircraft was expected to cost \$70 million (in 1972 USD).

Above: caption: "An artist's conception of the Boeing RC-1 transport aircraft"

270

"...Boeing's 'Flying Pipeline' is one answer to the problem of how to get all that recently discovered oil and natural gas out of the Arctic and down to fuel-hungry markets. Working closely with Boeing on this concept is Canada's Great Plains Project, Prime Minister Trudeau's think tank for development of his nation's resource-rich Far North. One of Canada's more promising resource areas is the Arctic Archipelago. But running pipelines underwater among these frozen islands probably isn't feasible; and the hostile environment pretty much rules out surface transportation..."

Popular Science, October 1972

RE: the Boeing RC-1 (for "Resource Carrier") was a joint development project of Boeing and the Great Plains Project, a think tank created by the Canadian government under Prime Minister Pierre Trudeau to develop the vast country's Far North. Of particular interest was extracting oil, natural gas and mineral ores from the Arctic Archipelago (the building of pipelines and/or roads between these frozen islands to transport these natural resources to an ice-free port or rail head was deemed unfeasible).

271



272

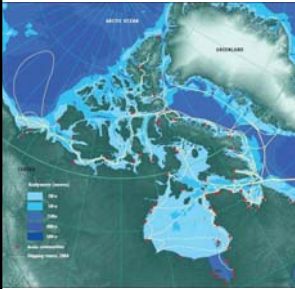

"...Canadian planners envision round-the-clock operation of a fleet of 50 RC-1 cargo jets to haul oil, liquid natural gas, and maybe mineral ores out of the Archipelago. At an ice-free port several hundred miles to the south, super-tankers and freighters would take aboard cargoes and complete the trip to market by water. Alternatively, the airlift might have one of Canada's new northern railheads as a transfer point..."

Popular Science, October 1972

RE: each RC-1 was to carry 2.3 million pounds of cargo

Left: caption: "Network of shipping routes serving major Canadian Arctic communities"

273

Economies of Scale

274

"...The RC-1 was designed specifically for such short-haul (typically under 1,000 miles) operations; rapid turn-around and high utilization are key factors for economic feasibility. The system had to match the flow capability of a 48-inch pipeline at comparable cost. To take advantage of the 'economies of scale' (studies showed that economy improved as size increased), the RC-1 designers really thought big..."

Popular Science, October 1972

275



"...This plane has the most awe-inspiring measurements of any heavier-than-air flying machine - even dwarfing Howard Hughes' legendary 'Spruce Goose.' Wing area of the RC-1 is almost 3/4 acre. It stands 86-feet overall, is longer than a football field between end zones..."

Popular Science, October 1972

Above: caption: "On November 2, 1947, eccentric airplane designer Howard Hughes performed the maiden flight of the Spruce Goose (a/k/a H-4 Hercules), the largest fixed-wing aircraft ever built"

276



277

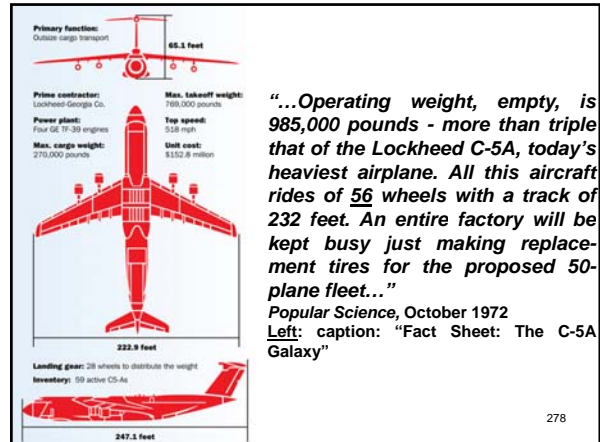

"...Operating weight, empty, is 985,000 pounds - more than triple that of the Lockheed C-5A, today's heaviest airplane. All this aircraft rides of 56 wheels with a track of 232 feet. An entire factory will be kept busy just making replacement tires for the proposed 50-plane fleet..."
 Popular Science, October 1972
 Left: caption: "Fact Sheet: The C-5A Galaxy"

278

"...Twelve Pratt & Whitney JT9D turbofans, similar to those of the 747, will push the RC-1 at a cruising speed of about 450 mph - fast enough for the short, 500-to-1000-mile hauls planned for this plane. By limiting the airspeed to Mach 0.65, the designers eliminated a sweptback wing and permitted a straight and relatively thick airfoil, rectangular in shape. This configuration is most efficient for supporting the loads of engines and cargo pods. Landing gear can be distributed laterally in a straight line..."
 Popular Science, October 1972

279

Turnaround and Go

280

"...Adaptable to a wide variety of cargo, each of the two externally carried pods can hold over 500 tons of payload. They are designed to accommodate the cross-section of four standard eight-by-eight-foot cargo containers; each pod is 26 feet in diameter and 150 feet long (for comparison: the Boeing 707 fuselage is 12 ft. four in. wide and 145 ft. six in. long). These detachable cargo pods, handled at the system's terminals by special transporters on rails, could be removed and replaced in just minutes for the required rapid turnaround. Other cargo could be carried in the cavernous fuselage..."
 Popular Science, October 1972

281

"...With its wide wheel track, the RC-1 needs a special landing strip 400 feet wide, although the length - 12,000 feet - is the same for existing commercial jets. Without a payload, the RC-1 could use conventional runways by leaving its outboard landing gear retracted. It appears that the 12-engine RC-1 would pass current U.S. Federal noise and exhaust regulations for new commercial jets. If methane is used for fuel, exhaust problems would be almost entirely eliminated..."
 Popular Science, October 1972

282

Path of Least Resistance (?)

283

"...The 'Flying Pipeline' looks like a promising way of getting much-needed fossil fuels and other natural resources to market - with minimal ecological impact. In the Arctic, surface modes of moving resources have to fight hostile environment - and environmental activists - almost every inch of the way. Canadian government and industry officials are therefore giving Boeing's RC-1 genuinely serious consideration. With construction of the Trans-Alaska pipeline delayed for three years now, maybe their U.S. counterparts should, too."
Popular Science, October 1972

284

Part 6

Touch the Earth Gently

285

The Senator From Alaska

286

"It would be easy to brush off as biased anything an Alaskan had to say in favor of the trans-Alaskan pipeline proposal. There is no question that the development of the North Slope oil fields is important to the State, primarily in terms of economic development. In 1970 the oil industry contributed some \$50 million in payrolls to the Alaskan economy, and provided approximately 5,000 jobs. Beginning the pipeline next year should increase that substantially. The Interior Department estimates that by 1976, at the height of the pipeline construction period, the oil industry will generate some \$400 million in personal income and create something like 30,000 jobs..."
Mike Gravel (D) - U.S. Senator for Alaska (January 1973)

287



"...We need the jobs for Alaskans and we need the new Alaskans that the jobs will bring north. Alaska needs the jobs for a prosperous and stable economy in the state. As an Alaskan, these things might temper my judgment on the wisdom of a line carrying two million barrels of oil every day from Prudhoe Bay in the Arctic to Valdez on the Gulf of Alaska. But overriding my economic self-interest is my concern for the Alaska environment, a concern shared by all Alaskans..."
 Mike Gravel (D) - U.S. Senator for Alaska (January 1973)
 RE: Gravel - a graduate from of Columbia University, moved to Alaska in the late 1950s, becoming a real estate developer and entering politics. He served in the Alaska House of Representatives from 1963 to 1966 and was elected to the U.S. Senate in 1968. He played a crucial role in getting Congressional approval for TAPS and was re-elected to the Senate in 1974. He served in the Senate until 1980.

288

The Great Land

289



"...No one who has witnessed the migrations of the caribou herds across the Arctic tundra, flocks of ducks and geese returning north to their nesting grounds each spring, or salmon making their yearly trip upriver, could be insensitive to the beauty and delicate balance of nature in the 'Great Land.' I have always believed we possess the technological expertise and skill to build a safe pipeline..."

290

Mike Gravel (D) - U.S. Senator for Alaska (January 1973)



Northern Lights sun-burst energy
Spirit color to the night sky pulsating
Survival in the last rugged frontier
Raw and scenic beauty in wild rivers,
Coastal waters, inlets, black sand beaches
Lush rain forests teem with life
Ancient glacial ice endures, moves
Denali mountain peaks inspire.

Eagle leads the way
Go on your spirit journey now
Follow your animal totem guide
Discover the path you may travel
Find your way in this life.

Alaska-The Great Land (Alaska State Poem)

291



292

The Study

293

"...After carefully weighing the evidence of the Department of the Interior's six-volume study on the pipeline, I am certain of it. The study itself is the most extensive ever undertaken to determine the effect of man on nature. Its conclusions are that little, if any, lasting damage will be done to the environment. Moreover, it makes mandatory certain standards that contractors must follow. These standards guarantee environmental protection..."

Mike Gravel (D) - U.S. Senator for Alaska (January 1973)

RE: the construction of TAPS would usher in many consequences - both good and bad. Millions of barrels of oil were made available for consumption at a time when they were desperately needed. Many believed, however, that this short-term gain could easily overshadow the environmental harm that could/would be caused by hundreds of miles of pipeline passing through a pristine, but harsh, wilderness. TAPS flows through natural biomes, upsets animal trails and/or migration routes and carries with it the potential of a catastrophic leak or spill that could, potentially, destroy fragile habitats.

294

"Although the mean distance for test groups passing in front of the simulator was smaller than the mean distance for control groups, there was no significant difference between the two. Therefore no indications of disturbance could be concluded from this data."

Disturbance Studies of Caribou and Other Mammals in the Yukon and Alaska, 1972 - Alaskan Arctic Gas Study Company

RE: in the early 1970s, a team of scientists traveled to Alaska to document the probable effects of the pipeline on the environment. Initially, they studied the trails of caribou and other large mammals and the quantity of furbearing animals to determine how these animals behaved without mechanical disturbances. For example, caribou routes were charted and placed on a map (left T&B). When an imitation oil compressor was introduced, the caribou showed little signs of disturbance. In fact, on average, they only diverged one-half of a mile from the simulation site.

Top: caption: "The paths of the caribou before the experiment"

Bottom: caption: "Alternative routes taken by the caribou" 295

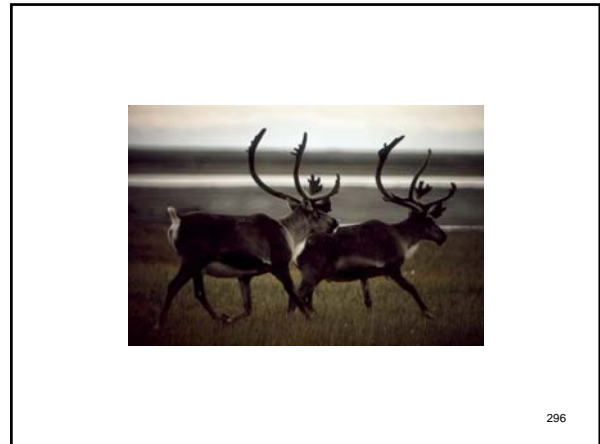
Furbearers were also shown to be mildly affected by TAPS. Trapping was a large portion of the area's economy and the scientists wanted to be certain that the obstructions would not upset the trade. The experiments concluded that the only negative influence was that in some places, the woodland ground cover was destroyed and did not grow back to the previous extent. However, the dens and lairs of the furbearing animals were only very mildly disturbed (since most of their locations did not conflict with the pipeline's route). Overall, the furbearers did not suffer significantly due to the presence of the pipeline - and neither would the trapping trade.

297

Not So Fast

298

"...The impact studies were initiated after a 1970 injunction won by environmentalists blocked the project. The federal court ruled that the Department of the Interior, which had given the go-ahead for construction, had failed to demonstrate the pipeline's potential impact on the state's ecology..."

Popular Science, January 1973

299

"...As a result of the studies, major changes affecting design and routing of the proposed line have occurred:

- Some 50 percent of the line would now be built above ground, instead of 5 percent as originally planned.*
- Routing has been altered to protect wildlife.*
- A device was developed to detect minute leaks along the line so shut-off valves could be triggered automatically.*
- An earthquake-warning system was designed to detect quakes before they occur.*
- In addition, a number of environmental 'baselines' were established so scientists can determine if ecological changes occur..."*

Popular Science, January 1973

300

A Quarter-of-an-Inch

301

"A bubbling sound helped workers pinpoint a leak in a pipeline that allowed thousands of gallons of crude oil to spill onto the frozen tundra in Alaska's Prudhoe Bay...The breach was discovered at 1:40 a.m. Sunday inside a low-lying section of the 34-inch transit line, which leads to the trans-Alaska oil pipeline. The section where the leak occurred is covered by gravel to let caribou pass...The source of the leak was found after enough snow had been removed from the site. The spill, discovered Thursday by a BP operator, prompted the company to shut down the processing plant, depressurize the line and block off both ends, but workers Sunday found that oil is still dripping from the breach..."

Associated Press, March 8th 2006

302

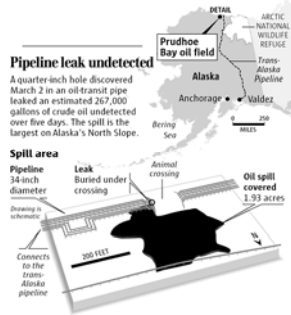

303



"...It's like putting a straw in soft drink and a finger on the straw. The fluid stays in the straw," said Matt Carr, onsite coordinator for federal Environmental Protection Agency. "Of course it's not a perfect seal. There's a little bit of dripping, but it's not a huge active leak"...As of Sunday afternoon, crews had recovered 1,097 barrels - or more than 46,074 gallons - of crude and snowmelt.

Associated Press, March 8th 2006

304

"...The amount spilled is far greater than BP and government officials are saying, according to oil industry critic Chuck Hamel. Hamel, of Alexandria, Va., said he learned from onsite personnel that the spill volume is closer to 798,000 gallons, which would make it the second largest oil spill in Alaska, second only to the 1989 Exxon Valdez spill of eleven million gallons in Prince William Sound..."

Associated Press, March 8th 2006

305

Tanqueray on the Rocks

306

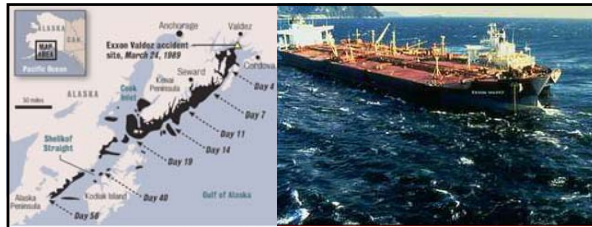

"Forget the drunken skipper fable. As to Captain Joe Hazelwood, he was below decks, sleeping off his bender. At the helm, the third mate never would have collided with Bligh Reef had he looked at his RAYCAS radar. But the radar was not turned on. In fact, the tanker's radar was left broken and disabled for more than a year before the disaster, and Exxon management knew it. It was, in Exxon's view, just too expensive to fix and operate."

Greg Palast, Reporter (2008)

Left: caption: "Map showing spread of oil from Exxon Valdez accident"

Right: caption: "Exxon Valdez spilling oil into the waters of Prince William Sound. She is leaking oil and about to face a storm."

307

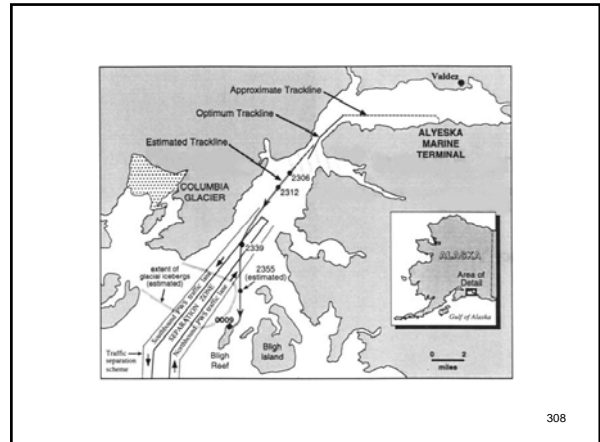

308



309

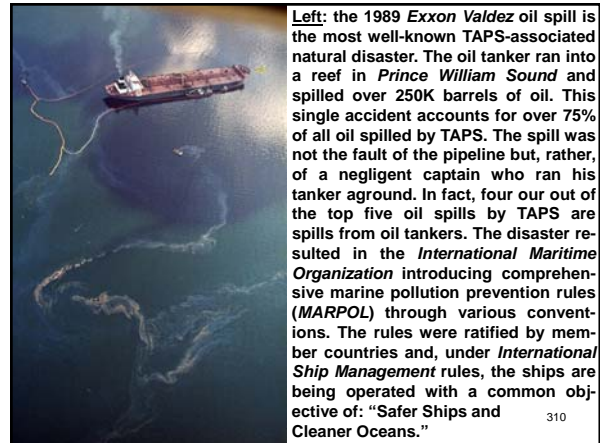

Left: the 1989 Exxon Valdez oil spill is the most well-known TAPS-associated natural disaster. The oil tanker ran into a reef in Prince William Sound and spilled over 250K barrels of oil. This single accident accounts for over 75% of all oil spilled by TAPS. The spill was not the fault of the pipeline but, rather, of a negligent captain who ran his tanker aground. In fact, four out of the top five oil spills by TAPS are spills from oil tankers. The disaster resulted in the International Maritime Organization introducing comprehensive marine pollution prevention rules (MARPOL) through various conventions. The rules were ratified by member countries and, under International Ship Management rules, the ships are being operated with a common objective of: "Safer Ships and Cleaner Oceans."

310

Exxon Valdez Oil Spill Facts

On March 23, 1989, at 9:12 p.m., the Exxon Valdez oil tanker left the Alyeska Pipeline to cross Prince William Sound carrying approximately 53 million gallons of crude oil. The tanker was headed for Long Beach, Calif. Three hours later, just after midnight on March 24th, the Exxon Valdez ran into Bligh Reef, spilling 10.8 million gallons of oil into the sound.

- » The amount of oil spilled could fill 125 Olympic-sized swimming pools.
- » 1,300 miles of coastline were hit by the oil spill.
- » The cleanup required about 10,000 workers, 1,000 boats and roughly 100 airplanes and helicopters.
- » Four deaths were directly associated with cleanup efforts.
- » The spill caused over \$300 million of economic harm to more than 32,000 people whose livelihoods depended on commercial fishing.
- » Two years following the Exxon Valdez spill, the economic losses to recreational fishing were estimated to be \$31 million.
- » Twelve years after the spill, oil could still be found on half of the 91 randomly selected beaches surveyed.

311



312

Human Error

313

"Alaska oil pipeline workers failed to follow procedures they had practiced for 10 weeks, leading to an explosion and fire that shut the pipeline this month, House investigators reported Tuesday. The House Interior Committee investigators said the July 8th explosion that killed one worker was caused by allowing oil to go through a pumping unit that was being repaired at the time. The oil rushed through an unsecured hatch into a pump building, where it ignited, the investigators said. The Interior Department had found earlier that human error caused the incident near Fairbanks and that the pipeline was not damaged. The department allowed the oil flow through the 798-mile pipeline to resume Monday...Repairs to the pump station will cost \$20 million to \$50 million and take six months to a year...The investigators said the incident could have been avoided if pipeline workers had followed the required maintenance procedures. But they recommended that electric sensors be installed to indicate automatically to personnel when repairs are being done...According to the report, the controller in Valdez heard the supervisor say, 'We have a fire. We've had a hell of an explosion.' Within eight minutes the flow of oil through the pipeline was stopped..."

Herald Journal, July 20th 1977

RE: an explosion on July 8th 1977 at Pump Station 8 (PS8) killed one worker, injured five others and destroyed the pump station. An investigative committee determined the cause was workers not following the proper procedures, causing crude oil to flow into a pump under repair, at the time.

314

Incidents

315



"If somebody wants to go to great lengths to damage that pipeline, they can. It's important to understand that it's 800 miles long and it's a monumental task to protect every inch of that pipeline 24 hours a day."

Tim Woolston, Spokesman - APSC (October 2001)

RE: APSC stepped up surveillance along the pipeline in the wake of the 9/11 terrorist attacks in September 2001. However, the 800-mile long pipeline, much of which runs through remote wilderness, remains vulnerable. Following the Exxon Valdez oil spill, APSC created a rapid response force that is paid for by the oil companies (including ExxonMobil, which was found liable for the spill). Since the startup of TAPS (on June 20th 1977), several incidents have caused the pipeline to be shut-down. The NTSB investigated and made recommendations. However, due to its great length and the remoteness of TAPS, it's more or less impossible to secure entirely.

Above L&R: TAPS warning signs (left) are not always effective (right)

316

"We anticipate it will take literally years to get the area free of contamination"

Bill Howitt, VP - Alyeska Pipeline Service Company, October 7th 2001

RE: the largest oil spill involving the main pipeline took place on February 15th 1978, when an unknown individual blew a 1-inch hole in it at Steele Creek, just east of Fairbanks. Approximately 16K barrels of oil leaked out of the hole before the pipeline was shut down. After more than twenty-one hours, it was restarted.

317



The steel pipe is resistant to gunshots and has resisted them on several occasions, but on October 4th 2001, a drunken gunman named Daniel Carson Lewis shot a hole into a weld near Livengood, causing the second-largest mainline oil spill in TAPS history. Approximately 6,144 barrels leaked from the pipeline (4,238 barrels were recovered and re-injected into the pipeline). Nearly two acres of tundra were soiled and were removed in the cleanup. The pipeline was repaired and was restarted more than sixty hours later. Lewis was found guilty in December 2002 of criminal mischief, assault, drunken driving, oil pollution and misconduct. He was sentenced to sixteen years in prison and ordered to repay the \$17 million cleanup costs.

318



Oil leak

"Our priority is that no oil migrates from the site to the Tolovana River a mile away"
 Brad Hahn, Alaska Department of Environmental Conservation
 RE: A helicopter spotted the leak close to the pipeline's midpoint, about 50 miles north of Fairbanks. The oil covered two acres of ground in an area of tundra and spruce. As part of the clean-up effort, crews dug ditches and deep holes to capture the oil, which was then vacuumed into tanker trucks and transferred to storage tanks (approximately 80K gallons were collected). In the aftermath, APSC officials stated that people had shot at the pipeline more than 50 times previously, but never caused enough damage to produce a spill.

319

All of the "Top-Ten" worst oil leaks from TAPS took place before 1990. After the *Exxon Valdez* disaster, governmental regulations were increased out of environmental concern. The qualifications for oil tanker navigators were raised and escort vessels are now required to guide the tankers in *Prince William Sound*. The alarm system on the pipeline itself has been modernized to detect leaks quickly. The line volume balance system measures the total oil that goes into the pipe versus the total oil coming out of the pipe to determine if there are small, slow leaks within the pipe. A transient volume balance system was added in 1998 and uses complex computer models to determine the theoretical pressure at different places in the pipe and compares it to the actual readings. One of the biggest concerns when the pipeline was built was the advancement of glaciers (no glaciers along the TAPS corridor have advanced since the pipeline was completed). However, there is concern as to whether or not their melting due to global climate change could/would cause the ground to soften and create problems for the integrity of the pipeline. Of course, the risk of sabotage due to terrorism is an on-going concern as well. All told, TAPS has proven to be a model for sustainable development - designed with economic efficiency as well as environmental impacts in mind.

320

All Things Considered

321

"...Provision is made for pollution control in all forms. The pipeline contractor will have to provide buffer strips one-half mile wide from wildlife areas, parks, historic sites, national landmarks, recreation areas. Fish and wildlife protection is contractually covered, and the restoration of any disturbed areas is required. The pipeline itself will be designed to withstand anything but the most severe earthquake. And damage from such a catastrophe will be minimal, since the design requires remotely controlled shut-off valves at all pump stations. In areas of terrestrial instability, a network of ground motion detectors will be installed and coordinated with a fast moving shut-down system..."
 Mike Gravel (D) - U.S. Senator for Alaska (January 1973)

322

"...But there are other considerations as well. Our diminishing domestic supply of petroleum, and the uncertain future of our traditional domestic supplies, make it foolish to ignore the reserves estimated at between 10 and 16 billion barrels of oil on the North Slope..."
 Mike Gravel (D) - U.S. Senator for Alaska (January 1973)
 RE: although TAPS had some negative environmental effects, it was less "ecodisruptive" than the alternative method of transporting *North Slope* Alaskan oil by land (i.e. roads). If a system of roads were built to transport the oil, road pollutants would cause plants to be more susceptible to pest attacks. Nitrogen oxide, a common pollutant from road traffic, causes forest "dieback." A series of roads to *Prudhoe Bay* would also open the door for further resource extraction and development/exploitation. TAPS only transports oil. Consequently, it safeguards against the removal of metals, agricultural products and other natural resources that could be developed. The "Great Land" can be preserved because the oil is transported without transport roads thus, TAPS does not encourage and/or facilitate further extraction of other natural resources.

323

Less than Reasonable

324

“...Finally, since time is of the essence, speculation as to the practicality of a trans-Canada line is less than reasonable. Not only has opposition been voiced by Canadian conservationists, but there are indications that it is not practical at this time. Atlantic-Richfield recently said that after researching the feasibility of such a project they did not consider it a 'viable alternative' to the trans-Alaska route, and announced their withdrawal from a group studying its potential. The proposed trans-Alaska pipeline will be the cheapest, fastest, and, most importantly, an ecologically safe way to exploit Alaska's vast petroleum reserves.”

Mike Gravel (D) - U.S. Senator for Alaska (January 1973)

RE: an alternative to TAPS lay to the east; through the *Trans-Canada Corridor*. Whether by rail or pipeline, this route would go through the heart of the *Arctic National Wildlife Refuge (ANWR)* – a key habitat for the endangered musk oxen population in Alaska (estimated at +/-1K). This limited population requires help to survive. No doubt roads and/or rail lines through the natural habitat of migrating animals would have had negative consequences, to say the least (approximately 200 moose are killed by trains and over 700 are killed by road traffic annually). Interestingly, musk oxen have now been spotted well west of *Prudhoe Bay*, meaning they have been able to cross under TAPS (at established crossing points in the line) undisturbed.

325

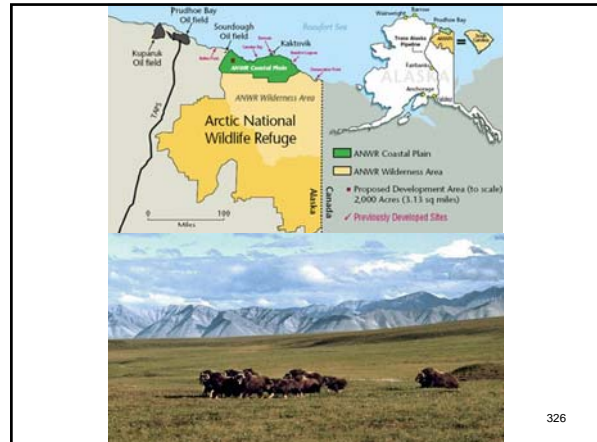

326

“It's a defensive effort. It has been since 1980 and it will continue probably until such time as the industry either decides it's a losing proposition or technology comes along to take the pressure off going into the Arctic refuge. The state of Alaska has constantly tried to open the refuge and they've failed. We are bound and determined to maintain the status quo out there.”

Jack Hession, Sierra Club's Alaska Representative

RE: there are few large-producing oil fields left to be exploited in the United States. USGS officials believe the best prospect lies 60 miles due east of *Prudhoe Bay*, in ANWR - a federally protected wilderness area. Speculation about the amount of oil in the ground varies considerably. Proponents say the site holds 16 billion barrels while opponents claim the number is closer to three billion barrels (U.S. Government officials estimate ten billion barrels). According to an *Energy Information Administration (EIA)* forecast, oil supplies flowing from the refuge (at peak production, in the year 2025) would reduce America's dependence on foreign oil from 70% to 66%. POTUS *George W. Bush* tried unsuccessfully (due to heavy lawmaker opposition) to commence drilling in ANWR on two occasions during his term/s in office. However, many Alaskans are in favor of drilling in ANWR considering the fact that since 1982, oil revenues have generated annual dividends for state residents.

327

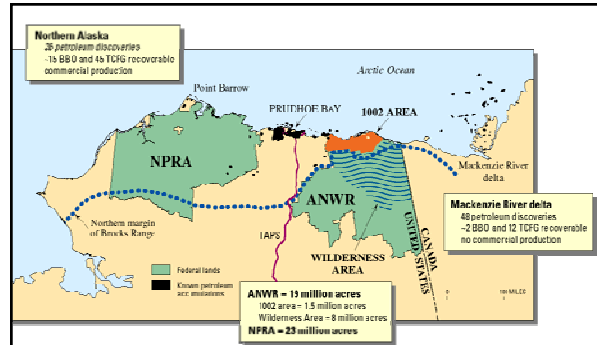

Above: caption: “Alaska's Arctic National Wildlife Refuge (ANWR), 1002 area, National Petroleum Reserve - Alaska (NPRA), Trans-Alaska Pipeline System (TAPS), and Locations of known Petroleum Accumulations (USGS)”

328

“There are many Alaskans who were pleased with the decision made by the U.S. Court of Appeals in further delaying the construction of the pipeline...Senator Mike Gravel stretches the truth when he states ‘...the court case will be valuable in the long run, for it will put to rest, once and for all, the argument that the line will harm the environment.’ This argument will never be put to rest because, if the line is built, there will be other damage; pipeline ruptures, faulty controls, and other human error that will cause accidents, ultimately hurting the environment.”

Art Fox, Anchorage, Alaska (April 1973)

329

The Coming Years

330

"I have written about 3,000 letters and articles opposing the Trans-Alaska pipeline, testified in Washington, and done a critical analysis of the final environmental-impact statement to the chairman of the Subcommittee on Public Lands. I still maintain that the Trans-Alaska pipeline will rival Vietnam and Watergate for the disillusionment it will cause the American people in the coming years. Let's face it, we opened another can of worms."

Kenneth Quade, Pembine, Wisconsin (July 1977)

331

"I know you'd find lots of Alaskans who thought that that was the beginning of the state standing on its own feet and finding its destiny and being able to pay for its own future. I think you'd find an equal number who would think something very special was lost when Alaska put all its eggs in one basket."

Howard Weaver, Anchorage Daily News reporter (1972-1976)

RE: the building of TAPS provoked intense feelings among Alaskans. Most of the state's residents were either strongly for or strongly against the project, with few in between.

332

The Eleventh Commandment

333



"It's the 11th Commandment. There were only 10. The 11th Commandment is, we've got to build that pipeline, and it was good. It's good for America. It's good for the companies. It's good for the people. It's done right."

Walter J. Hickel (R), Governor of Alaska (1966-1969)

RE: at the forefront of pro-development forces was Governor *W.J. Hickel*, arguing that TAPS would bring Alaska much needed revenue to build proper roads, schools and provide decent health care, all of which were lacking in the 49th State.

334

Cost-to-Benefit Ratio

335

"There's no such thing as a free lunch. There are always some problems. There's always some price to pay for it. But the price was cheap and the benefit was great."

Chancy Croft (D), Alaska State Senator

336

And Everything Else, Too

337

"The wealth generated by Prudhoe Bay and the other fields on the North Slope since 1977 is worth more than all the fish ever caught, all the furs ever trapped, all the trees chopped down; throw in all the copper, whalebone, natural gas, tin, silver, platinum, and anything else ever extracted from Alaska too. The balance sheet of Alaskan history is simple: One Prudhoe Bay is worth more in real dollars than everything that has been dug out, cut down, caught or killed in Alaska since the beginning of time."

Terrence Cole, Alaska Historian

338

That Thing

339

"That thing cut through indigenous land a long ways. That can't help but have an impact directly on life, on hunting, on anything. Then on the other hand during those years we had a lot of poverty, you know, for Alaskan Native people in particular. All of this is a result - the pipeline is the final thing that happened. And so it's kind of like the final symbol. And that symbol itself, that tangible thing, that pipe that runs through the land is the thing that we have to learn to live with."

Diane Benson, Tlingit (Native Alaskan Tribe)

RE: more than any other group, Alaska's native peoples stood to lose the most from TAPS. For years, they had tried unsuccessfully to make a claim to land that was in the hands of both the state and federal governments. The discovery of oil in 1968 changed the dynamics of the situation in their favor. Yet, despite the money, land and political power gained, something precious to their ancient way of life was gone forever, and they knew it.

340



341

"We learn from Alaska that all Americans share in the ownership of its incomparable resources, its wildlife, its irreplaceable beauty, its wilderness. And that what happens in the future will depend on the American people as they raise their voices and express their interest in saving the best of Alaska for future generations, our grandchildren. We as American citizens are in control. We can dictate to our Congress, by expressing our views, becoming active in this controversy. This is our obligation as American citizens."

Stewart Brandborg, Director - Wilderness Society

RE: for many (especially environmentalists), Taps was symbolic of a lost wilderness. The damage was not only physical, but also affected the collective psyche of Americans. After all, Alaska was "The Last Frontier" - the last great American wilderness. While unsuccessful in stopping the construction of TAPS, environmental activists did make oil company executives more environmentally conscious. Ultimately, what emerged was a safer, cleaner, more ecologically conscious TAPS.

342

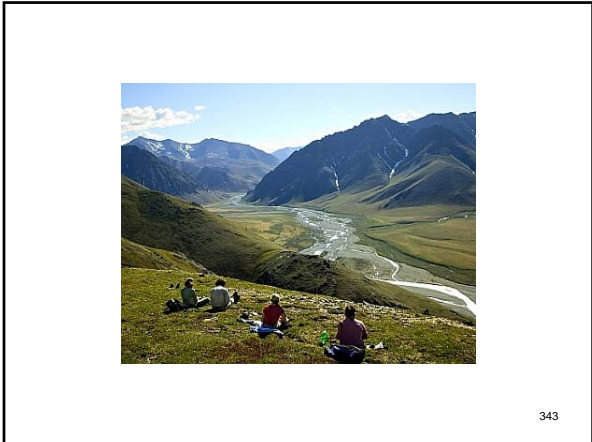

343

In the National Interest

344

"...Much of Alaska's 586,000 square miles of land also is undergoing change of ownership. When Alaska became a state in 1959, more than 99 per cent of the land was owned by the federal government. Today the government is in the midst of a complicated process of turning some land over to the residents of the state and setting aside other lands for preservation as national parks or monuments, national forests, wildlife refuges, scenic reserves or for other purposes. Under the Alaska Native Claims Settlement Act, passed by Congress five years ago, 40 million acres are to be turned over to the state's Eskimos, Aleuts and Indians; up to 80 million additional acres will be set aside in the national interest. This process is to be completed by December 1978, and a myriad of difficult questions remain to be decided..."
 CQ Press, December 17th 1976

345

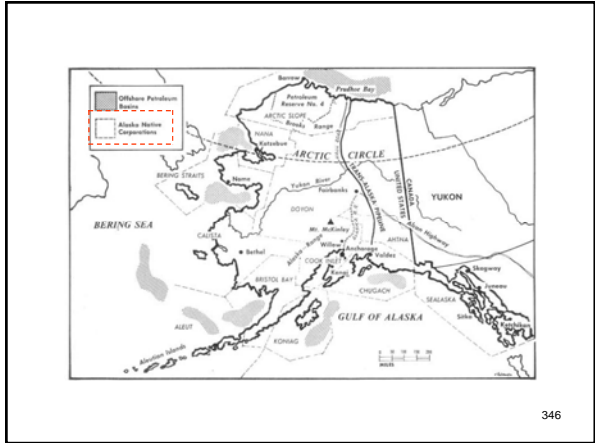

346

Part 7
Safeguarding the Future

347

There's Oil Down There!

348

"On May 2, 1967, a DC-3 with half dozen of us on board flew through the mountains of the Brooks Range directly over Anaktuvuk Pass. As I looked over the long gradual ramp of the North Slope, where the continental divide slowly merges with the Arctic Ocean, a vision hit me, or call it intuition. I saw an ocean of oil. 'There's 40 billion barrels of oil down there,' I said."

Walter J. Hickel (R), Governor of Alaska (1966-1969)

RE: in 1966 W.J. Hickel, a millionaire real estate developer and entrepreneur, ran for Governor of Alaska on the Republican ticket. Much to everyone's surprise, he won by a narrow margin of just eighty votes. A novice politician, in his inaugural speech he made it clear that one of his major priorities was to open the Arctic, believing it would help Alaska catch up economically with the "lower 48." Shortly after he was sworn in, Hickel approved the sale of oil leases on 37K acres of the North Slope, a decision that had been postponed by the previous governor because of protests from Alaskan Natives.

349

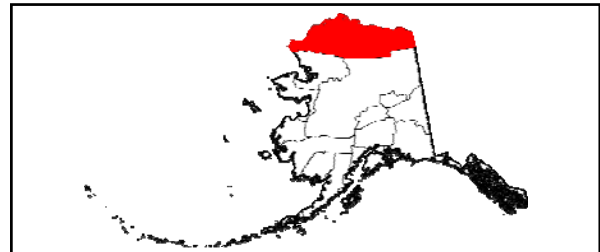

"Beneath the Otter's twin wingtips, Alaska's Oklahoma-size treeless North Slope stretched out like a white blanket, reaching for the Arctic Ocean beyond the horizon. Under the North Slope's tundra lie three pools of oil that may exceed any previous discovery: 10 billion barrels. Oil companies paid \$900 million for the lease rights alone..."

Popular Science, January 1973

RE: British Petroleum (BP) had come up empty-handed while exploring for oil on Alaska's North Slope (above, in red). Just when BP had been about to give up, Atlantic Richfield (ARCO) and Humble Oil (ESSO) tapped into a vast oil field in the early Spring of 1968.

350

"All of sudden we were down, I'd say it was well over 8,000 feet. The geologists knew something was looking pretty good by what was coming up out of the hole. The bit was chewing its way down. They have a method of putting a valve on the wellhead and they're able to test the flow and pressure with this valve mechanism. When it came time for that point, everyone was excited. We just took a cat and ripped open a big pond area or pit. They called it a reserve pit and it was dug as deep as you can get in the permafrost. They pushed it out maybe a football width and length - a big square. So then they began testing that and, lo and behold, they started opening that valve and doing all the readings and there was just no end to it. That crude oil just billowed out into the reserve pit and filled it right up."

Jerry Landgrebe, Oil Drill Operator (Prudhoe Bay, 1968)

RE: working twelve hours a day, sometimes sixteen, Landgrebe and his co-workers set the drill up on a platform (to prevent it from melting the permafrost)

351

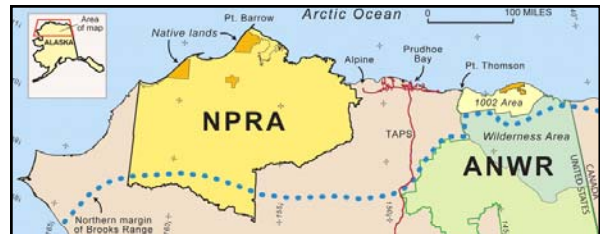

Above: caption: "A map of northern Alaska; the dotted line shows the southern boundary of the North Slope. The National Petroleum Reserve - Alaska is to the West, the Arctic National Wildlife Refuge to the east, and Prudhoe Bay is between them. Red lines are pipelines." The Prudhoe Bay Oil Field covers 213,543 acres and is the largest oil field in both the U.S. and in North America. The amount of recoverable oil in the field is more than double that of the next largest field in the United States, the East Texas Oil Field.

352



353

The Stillness of the Wilderness

354

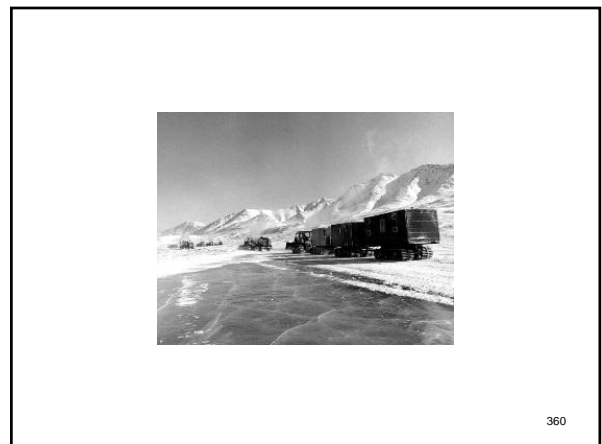
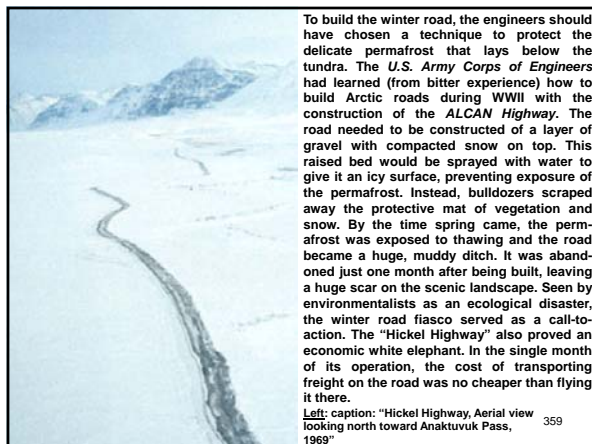
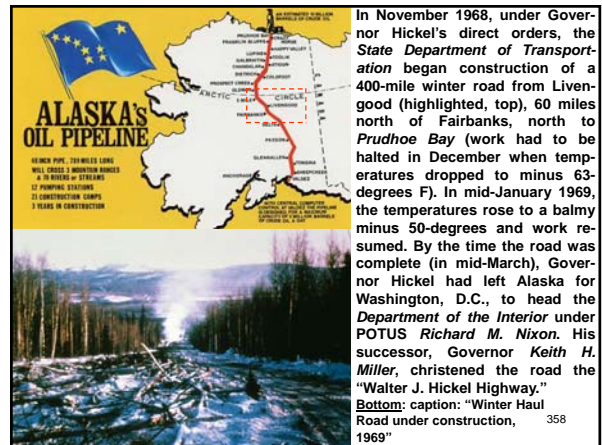
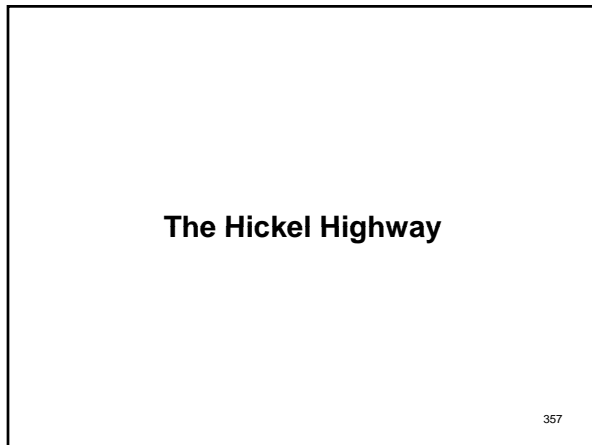
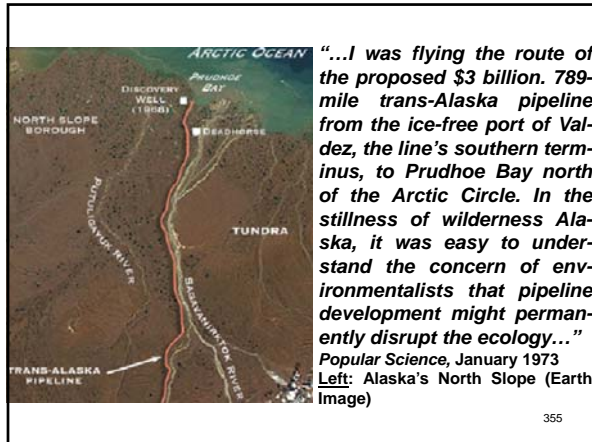

Reasonably in Balance

361



"...After a week-long, 2,000-mile trip along the route, one impression emerged above all others. Whatever the pros and cons of construction, Alaska has benefited greatly from the spin-off of more than 400 separate environmental impact studies generated by the oil discovery. Alaska is the first major test of a new doctrine: A project must be proved environmentally harmless, or at least its benefits and damage must be reasonably in balance, before a spade full of dirt is turned..."

362

Above: caption: "Colville River, Alaska"

We're Not in Kansas Anymore

363

"We had a group called Mile by Mile Design. There are a lot of pipelines where they do it typical. They say, okay, it's going to be buried six feet deep and you're going to go across Kansas and that's all you have to do. This thing (the pipeline) was being invented as you went along."

Bill Howitt, Alyeska Engineer

RE: Alaska is an enormous state with an incredible variety of terrain and weather. When Alyeska's engineers began designing TAPS, federal geologists and environmentalists noted that unique obstacles (including permafrost and earthquakes) would challenge the idea that the pipeline could be constructed underground in the usual, familiar way. By definition, permafrost is any rock or soil material that has remained below 32-degrees F continuously for two or more years. There are five different types of permafrost: *cold, ice-rich, thaw-stable, thaw-unstable* and *warm permafrost*. The two-year minimum stipulation is meant to exclude the overlying ground surface layer (which freezes every winter and thaws every summer). This layer is called either "active layer" or "seasonal frost." Problems that arise as a result of permafrost existence are *Frost Heaving, Frost Jacking* and *Thaw Settlement*.

364



365

Technological & Environmental

366

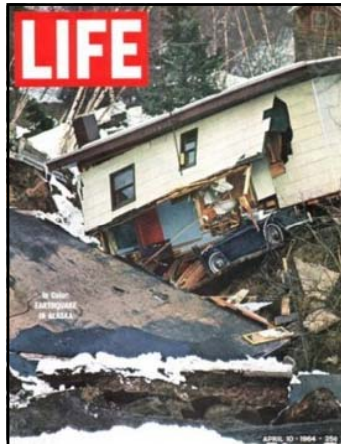

"...Building a pipeline in the Arctic multiplies problems, both technological and environmental, faced elsewhere. Between Prudhoe and Valdez, the route will cross streams that are spawning grounds for grayling and trout. Alaska, too, is seismically active; in the past 70 years, 23 major earthquakes have rattled the terrain over which the pipeline will pass. And Arctic ecology is delicate, especially in the vast areas of tundra, where the 1,800-foot-deep permafrost never thaws..."

Popular Science, January 1973
 Left: caption: "LIFE cover - Alaska-earthquake, April 10, 1964" 367

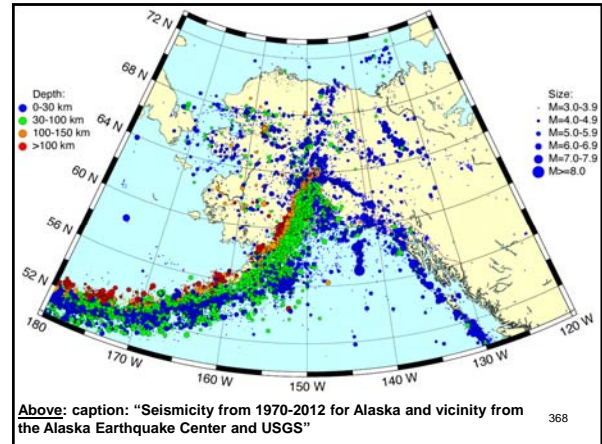

Above: caption: "Seismicity from 1970-2012 for Alaska and vicinity from the Alaska Earthquake Center and USGS" 368



Left: caption: "Pipeline on slider supports where it crosses the Denali Fault." The Pipeline Authorization Act required the pipeline to be able to withstand the maximum earthquake ever recorded in the area it was to be built. When crossing the Denali Fault, Teflon-coated sliders were designed to allow the pipeline to move side-to-side in an earthquake. To protect against forward-and-backward shocks and to allow for thermal expansion, the pipeline wasn't designed as a straight line. Instead, it was intended to be laid in an S-shape, the bends allowing for expansion and movement without breaking.

369



370

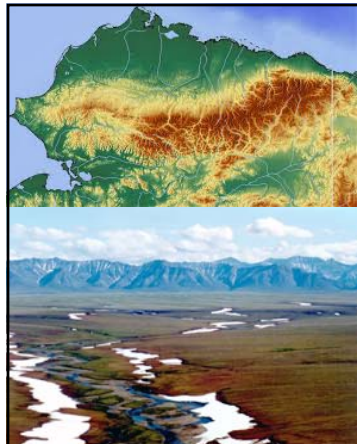

"...The job would be rigorous even in a warm climate,' acknowledges E.L. Patton, president of the Alyeska Pipeline Service Co., a consortium of seven oil companies formed to design, build, and operate the project. 'In the hostile mountains and tundra, it's formidable. The line must cross three mountain ranges, including the 150-mile-wide Brooks Range, and 350 rivers and streams. It must account for glaciers,' says Patton..."

Popular Science, January 1973
 Top: caption: "Brooks Range"
 Bottom: caption: "Area of the Arctic National Wildlife Refuge coastal plain, looking south toward the Brooks Range" 371

"...Following the discovery of oil in 1968, oilmen weighed and discarded other means of transport as either too risky, too costly, or too inefficient, and engineers bent over their drawing boards. Normally, such a line would be routed along the shortest distance between terminal points. 'But we couldn't do that in Alaska,' an Alyeska engineer explained. 'In operation, oil will heat ups as it flows - as high as 145-degrees. In permafrost areas, that would melt the ice around the pipe, causing supports to sag and break. So we sought a route where we could run it instead through gravel and rock wherever possible; we'll pack the pipe in a heat-containing cement 'blanket' where it isn't..."

Popular Science, January 1973

372

Where It Isn't

373

"...the heat pipe, a simple but spectacularly efficient heat exchanger that requires no external power and has no moving parts...The heat pipe isn't much to look at: a sealed tube, containing a working fluid and a wick that just sits there and moves heat. A pipe one inch in diameter and two feet long can transfer 12,500 BTUs an hour at 1,800-degrees F with only an 18-degree temperature drop from end to end. That's about 1,000 times the efficiency of a solid silver bar the same size. All you do is heat one end of the tube. The working fluid evaporates, absorbing large amounts of heat, and moves to the other end of the tube. There it condenses, giving up the heat and flowing back through the wick to start the cycle again..."

Popular Science, June 1974
 RE: heat pipes transfer heat from the heat source (evaporator) to the heat sink (condenser) over relatively long distances through the latent heat of vaporization of a working fluid

374

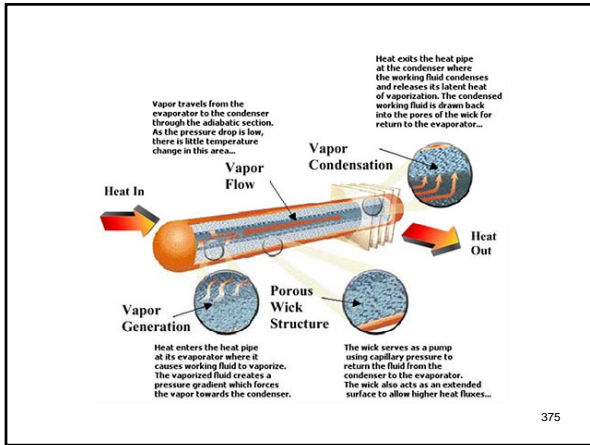

"...Credit for inventing the heat pipe goes to Richard S. Glaugher, a General Motors engineer who developed the idea in the 1940s, used the device in a refrigerator, but that was about it. The heat pipe was, in effect, reinvented in the early 1960s by George M. Grover of the Los Alamos Scientific Laboratory...Despite early optimism about heat pipes, the 1960's are littered with the wreckage of corporate efforts to market the devices..."

Popular Science, June 1974

376

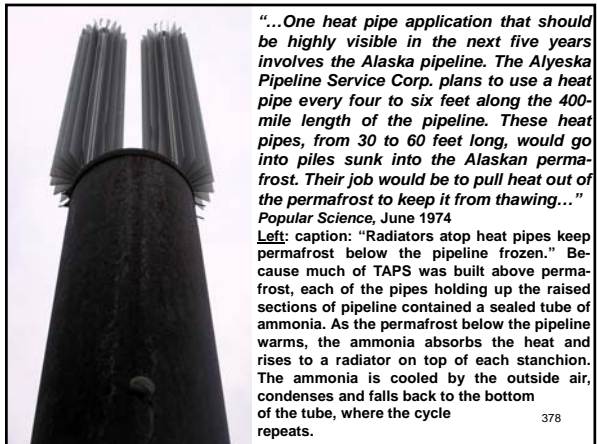
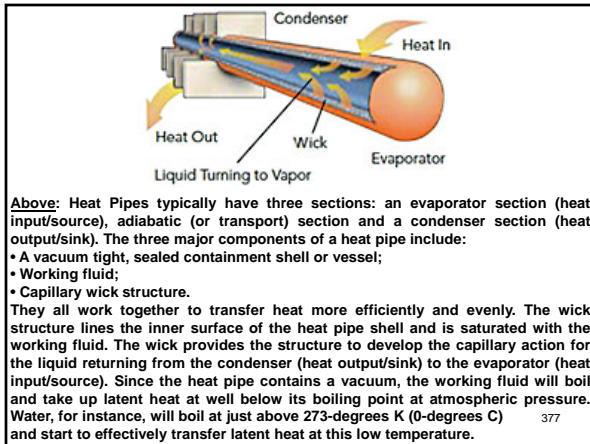

"...Five companies are competing for production of anywhere between 80,000 and 120,000 heat pipes. Both in number and dollar value - Alyeska isn't saying, but it could be in the neighborhood of \$30 million - this would be as much heat-pipe business as the industry has to date. It's probable that the contract will be split among several companies, giving heat pipes an enormous boost..."
Popular Science, June 1974

379

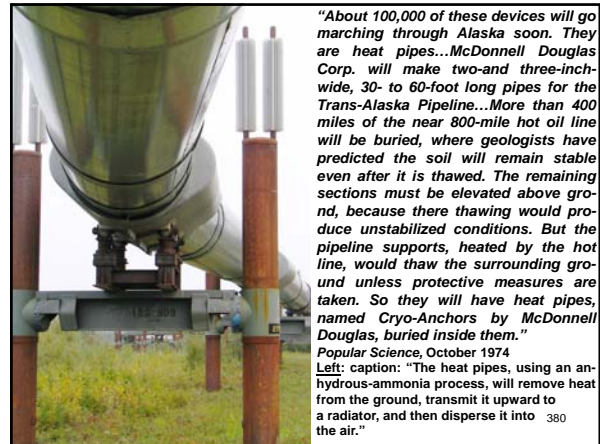

"I first heard about this in August 1969. I met an old colleague, Irv Tailleir, and he said, 'Art, did you realize the Trans-Alaska people have put in a request to Secretary of the Interior Hickel to build a pipeline? The pipeline will be buried in a trench, mostly in permafrost.' And we looked at each other in sort of a manner of disbelief."
Art Lachenbruch, U.S. Geological Survey (USGS)
 RE: Lachenbruch, a geologist at the USGS in Menlo Park, CA, was an expert in permafrost; the rock-like layer of frozen soil just below the thin, insulated cover of soil and vegetation. In December 1970, he released a study in which he explained the damage a hot pipe would inflict upon the permafrost. At a temperature of 158 to 176-degrees F, the oil in the pipe would thaw a cylindrical area 20 to 30-feet in diameter within a decade. The thawing would cause damage not only to the pipe, but also to the surrounding landscape. Lachenbruch voiced his concerns to his superiors, which led to the complete redesign of the pipeline.

382

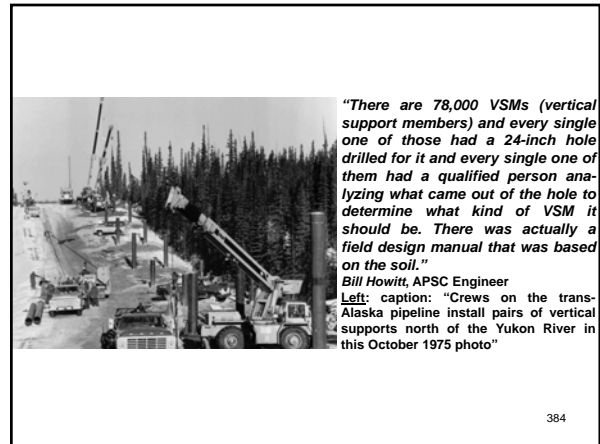
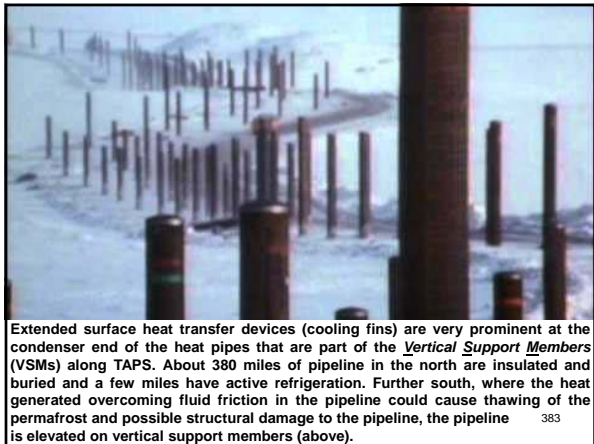

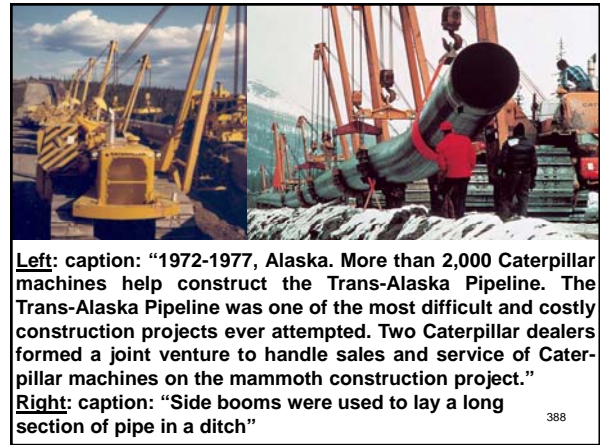
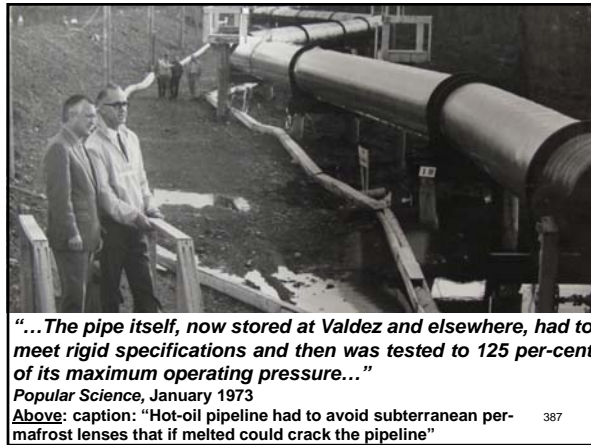
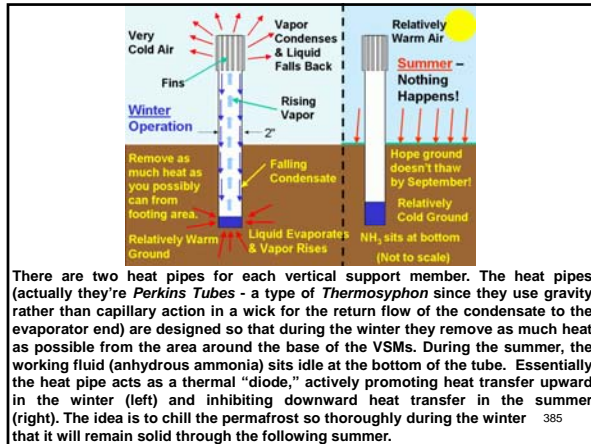

Heaving and Jacking

390

Permafrost is any rock or soil material that has remained below 32-degrees F continuously for two or more years. The hot pipeline, if on the ground, could thaw unstable, poorly drained, fine-grained soils which usually contain large amounts of ice (especially when they're "warm permafrost," just below 32-degrees F). This melting could cause the pipeline structure to sink into the ground. Engineers also had to contend with "Frost-Heaving/Jacking" (when ice forms and pushes the ground surface upward) of the pipeline structure. The elevated system includes specially designed vertical supports, which are placed in drilled holes or driven from 15 to 70-feet into the ground. TAPS includes 78K of these supports, usually 18-inches in diameter and 60-feet apart. If the pipeline had to be buried in these areas to go under highways, provide animal crossings and/or to avoid possible avalanches, the line was insulated to protect the permafrost from the pipeline's heat. In warm permafrost and other areas where heat might cause thawing, the supports contain two, two-inch diameter "heat pipes" containing *Anhydrous Ammonia*. The ammonia vaporizes below ground, but rises and condenses above ground, removing ground heat whenever the ground temperature exceeds the temperature of the air.

391



With 75% of the 800-mile-long pipeline passing through permafrost terrain (above L&R), Alyeska's engineers came up with three principal redesign plans to fit the needs of each particular area. APSC buried 380 miles of the line. Four hundred and twenty miles would be elevated on supports or pilings. The soil on every inch of the pipeline would be tested to figure out which design worked best. Soil samples were taken from locations along the proposed route of the pipeline. Following are examples of the pipeline design to cope with these soil conditions.

392

1. Thaw-Stable Soil

This soil condition allows the pipeline to be buried in the conventional manner, consisting of digging an 8-foot wide trench to a depth of 8-16-feet and infilling with layers of non-sharp fines, gravel and fine loam, buffer board packers being used as required.

The pipes are laid on top of this with sacrificial zinc anode ribbons laid alongside them. As well as being an anticorrosive measure, these zinc ribbons also act as telluric current conductors, returning any electric current picked up back to earth.

393



Pipe could be buried in three types of ground: permanently thawed soils, bedrock and some areas of permafrost which, when thawed, were considered unlikely to cause damage to the pipe. This permafrost was usually a mixture of sand, gravel and ice. Although the method was conventional, the pipeline was not buried like other oil pipelines (like those in Texas) which are generally buried in a ditch at a uniform depth. Instead, in Alaska, depending on soil conditions, the APSC engineers buried the pipes at depths of up to 16-feet. This method was used for 376 miles of the pipeline's total length.

394

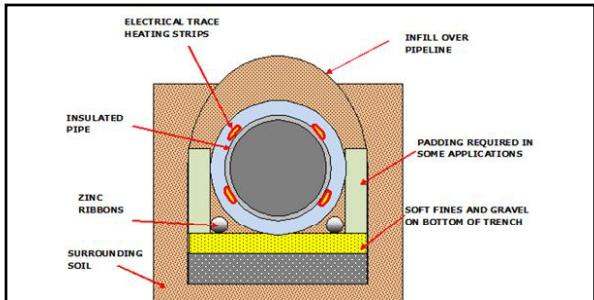

Approximately 376 miles of the pipeline (where there is solid bedrock not threatened by permafrost) is conventional below-ground construction. The pipeline is buried in a ditch that is 8 to 16-feet deep in most locations, but up to 49-feet deep in one location. Below-ground pipe is underlain with a layer of fine bedding material and covered with prepared gravel padding and soil fill.

395

Above: caption: "Section Through a Pipe Buried in Thaw-Stable Soil"

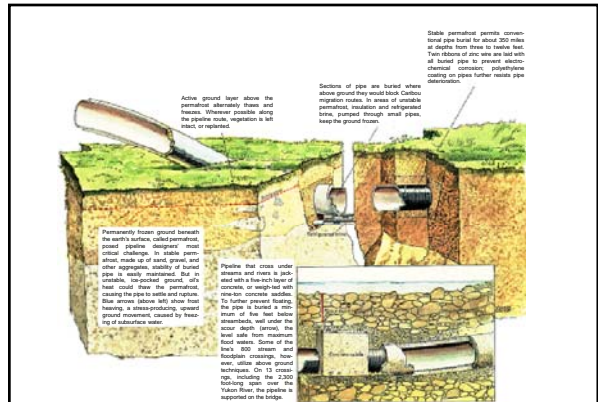

396

2. Thaw-Unstable Soil

If this permafrost is disturbed by heat subsidence will occur, so the insulated pipeline is installed well above the soil, on specially developed supports.

In hot permafrost areas where the heat may also cause subsidence and affect the pipe supports an additional method is employed to keep the permafrost from melting.

This consists of inserting two pipes into the permafrost containing a solution of anhydrous ammonia that vaporizes in the permafrost. The vapor rises up the pipes before condensing in a heat exchanger integral with the vertical support leg, maintaining the ground temperature below the air temperature.

397

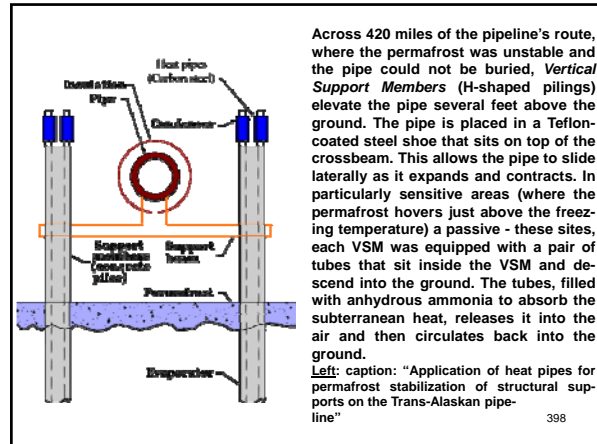

Across 420 miles of the pipeline's route, where the permafrost was unstable and the pipe could not be buried, *Vertical Support Members* (H-shaped pilings) elevate the pipe several feet above the ground. The pipe is placed in a Teflon-coated steel shoe that sits on top of the crossbeam. This allows the pipe to slide laterally as it expands and contracts. In particularly sensitive areas (where the permafrost hovers just above the freezing temperature) a passive - these sites, each VSM was equipped with a pair of tubes that sit inside the VSM and descend into the ground. The tubes, filled with anhydrous ammonia to absorb the subterranean heat, releases it into the air and then circulates back into the ground.

Left: caption: "Application of heat pipes for permafrost stabilization of structural supports on the Trans-Alaskan pipeline" 398

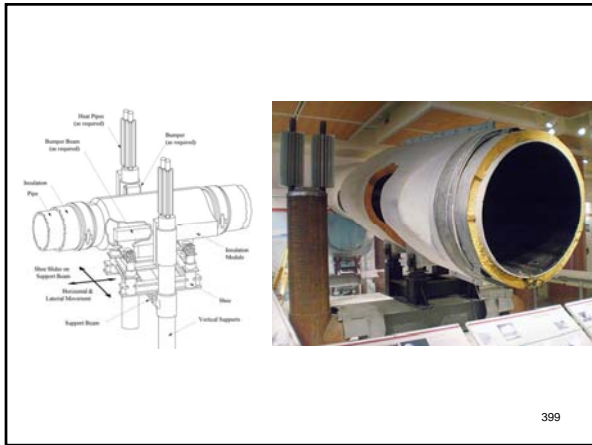

399

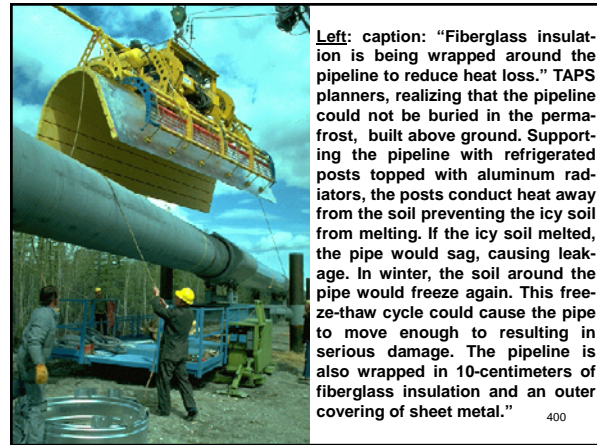

Left: caption: "Fiberglass insulation is being wrapped around the pipeline to reduce heat loss." TAPS planners, realizing that the pipeline could not be buried in the permafrost, built above ground. Supporting the pipeline with refrigerated posts topped with aluminum radiators, the posts conduct heat away from the soil preventing the icy soil from melting. If the icy soil melted, the pipe would sag, causing leakage. In winter, the soil around the pipe would freeze again. This freeze-thaw cycle could cause the pipe to move enough to resulting in serious damage. The pipeline is also wrapped in 10-centimeters of fiberglass insulation and an outer covering of sheet metal." 400

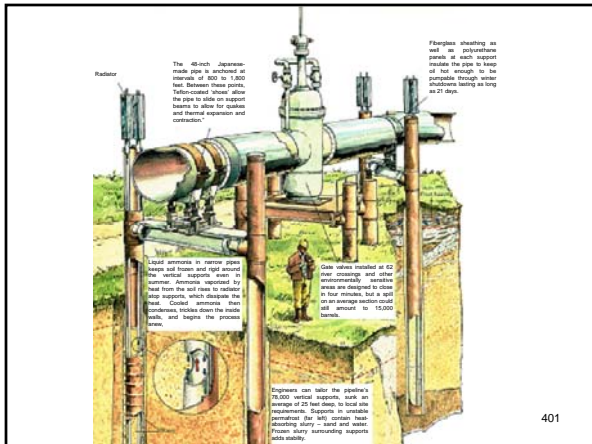

401

3. Special Soil Conditions

I. In permafrost soils where for various reasons the pipeline was required to be buried, the pipes were insulated to a thickness of 4-inches and buried in the normal manner.

II. Some locations required the pipeline to be buried in a refrigerated trench; here the pipes are insulated and buried as above. Brine refrigeration is circulated around the trench through 6-inch pipes to maintain the condition.

402



For four miles of the TAPS route, neither the conventional buried method nor the elevated one was possible. At these locations, pipe had to be buried in the permafrost to avoid interfering with a road/highway and/or animal migration routes, as well as a precaution against rockslides and/or avalanches (i.e. *Atigun Pass* in the *Brooks Range*). These stretches of pipe required their own refrigeration system. The pipe sits on two, six-inch coolant pipes. Refrigerated brine is circulated through these lines (powered by electric motors that are housed in a nearby building), which also contains a heat exchanger that removes the heat from the coolant to the outside air. The brine goes into the ground at 8 to 10-degrees F and comes out at 18 to 21 degrees F. 403



Above: caption: "Where the line crosses roadways in permafrost zones, like at the Glenn Highway, a major road artery for the state, the pipeline goes underground. Here it is enclosed in material that is cooled by refrigerated pipes buried along side it. Pumping stations nearby keep the refrigerant circulating." 404



405

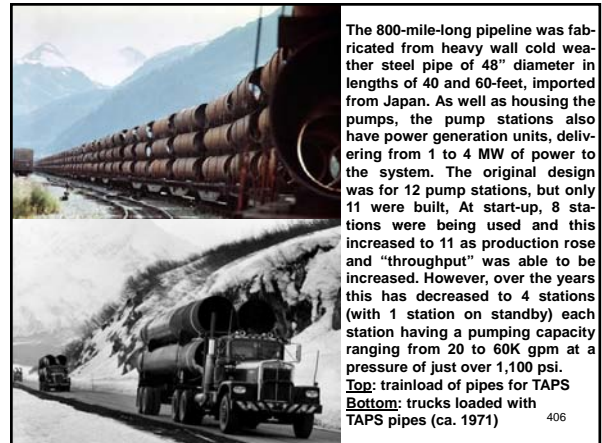

The 800-mile-long pipeline was fabricated from heavy wall cold weather steel pipe of 48" diameter in lengths of 40 and 60-feet, imported from Japan. As well as housing the pumps, the pump stations also have power generation units, delivering from 1 to 4 MW of power to the system. The original design was for 12 pump stations, but only 11 were built. At start-up, 8 stations were being used and this increased to 11 as production rose and "throughput" was able to be increased. However, over the years this has decreased to 4 stations (with 1 station on standby) each station having a pumping capacity ranging from 20 to 60K gpm at a pressure of just over 1,100 psi. Top: trainload of pipes for TAPS Bottom: trucks loaded with TAPS pipes (ca. 1971) 406

Pipe Specification

• **Lengths**
The pipeline was fabricated from special cold-weather steel pipe, in 40' and 60' lengths.

• **Grades**

1. API Grade X60: 0.462 wall thickness.
2. API Grade X65: 0.562 wall thickness.
3. API Grade X70: 0.562 wall thickness.

• **Insulation**

1. Above Ground: 3.75"
2. Refrigerated below ground: 3.2"
3. Under gravel or road: 2-4"

Therm-O-Trol: Polyurethane foam produced by GEC is used on the pipeline.

• **Trace Heating to Maintain 180°F**
Skin trace heating strips are fixed to the outside of the pipe before insulation is applied.

• **Thermal Expansion**
As the pipeline expands and contracts; this is counteracted by laying the pipes in a zigzag pattern, the supports having sliding shoes to accommodate this movement.

• **Intelligent Pigs**
These are inserted to inspect the inside bore of the pipeline for corrosion, stress, or deformity. They are pushed along the pipeline by the pressure of the oil, transmitting their data back to the control room.

• **Cleaning Pigs**
These pigs are inserted periodically to clean the sludge and wax from the inside of the pipeline. 407



408

A Torpedo-Like Gadget

409

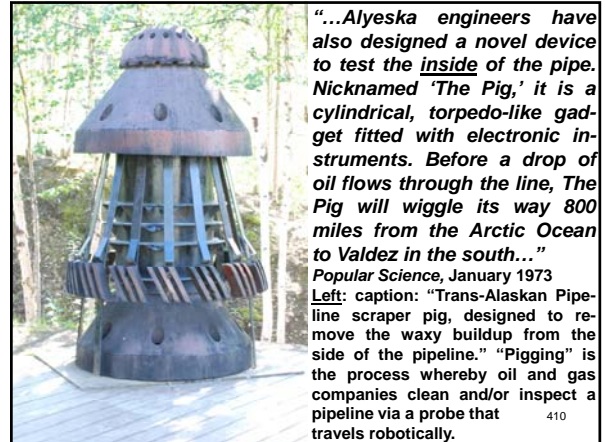

410



Sign (top, highlighted): caption: “Pigs in the Pipeline - Devices called ‘pigs’ improve the flow of oil through the trans-Alaska pipeline and monitor its condition. Pigs are launched and retrieved at pump stations and travel through the pipeline with the moving oil. The orange polyurethane sample in this pipe segment is a cleaning and flow improvement pig. Other more sophisticated pigs use magnetic fields and ultrasonic signals to detect small changes in the pipe’s wall thickness and shape. Pigs are among the most important tools available for protecting the pipeline and detecting potential problems.”

411

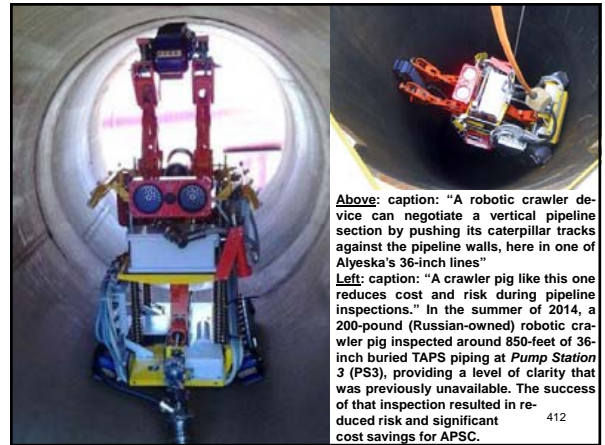

412

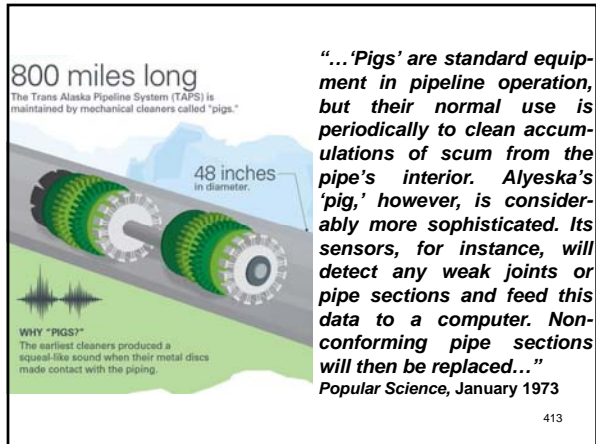

413



414

So What's the Problem?

415

TRANS ALASKAN PIPELINE SYSTEM, 800 MILES

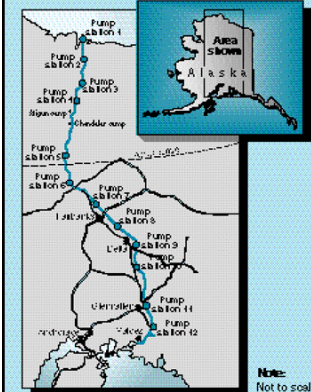

"The declining flow of oil from Alaska's North Slope is creating anxiety among executives who run the trans-Alaska pipeline. Within a matter of years, they say, they will need to take costly steps to preserve the life of the 800-mile-long line. If they aren't successful, ice and wax could become a serious problem for the pipeline, increasing the risk of corrosion and spills. Alyeska Pipeline Service Company's sense of urgency isn't because the North Slope is running out of oil. The Slope's producing oil fields still contain enough oil to supply the pipeline for at least several more decades. Many other oil prospects on land and in the ocean remain unexplored. So what's the problem?..."

Juneau Empire.com, January 4th 2010

Left: caption: "800-mile-long TAPS, which transports crude oil from Prudhoe Bay to Valdez, AK, consists of 48-in. OD pipe, 416 0.462 and 0.562-in. W.T., of API 5L X-60, X-65, and X-70 Grade."

Note: Not to scale

"The pipeline pretty much parallels what's called the Haul Road for 200 or 300 miles up the North Slope of Alaska. The North Slope is sort of a gentle slope like Kansas but it goes from sea level up to 5,000 feet in 150 miles. So you've got the oil a mile high and it wants to run down the hill. When the pig is there to inspect the pipeline, ideally it'd be going nice and slow and smoothly. But as it crests the hill and starts going downhill, it can get going pretty fast and the sensors can break or the wires can snap or the whole thing can heat up and melt. Then as the pipeline keeps going there are more pump stations pushing it up and over the Alaska Range and over the Chugach range. The steepest drop is down the Chugach Range, as it nears the final descent to Valdez and the port where the oil is put on boats and shipped to California and Washington. That part of the pipeline was the hardest to build. They were raising and lowering bulldozers using huge cables. It's very steep and much of that rock is pretty crumbly, so they buried it and encased it in concrete..."

Jonathan Waldman, Author (April 2015)

417

"...In the 1980s, at peak oil flows, a barrel of oil made the trip from Prudhoe Bay to Valdez in four days. Now it takes 13 days. The slower flow causes the temperature of the hot oil to cool faster. At some point, the oil temperature will dip below the freezing point of water along certain segments, unless Alyeska reheats the oil inside the pipe. As it gets colder, ice and wax may coat the insides of the pipeline. The colder oil might also increase the risk of buried segments of the pipeline jacking up in the ground, company officials said. The problems have been building for decades and will only become more pressing as oil production declines further..."

Juneau Empire.com, January 4th 2010

418

"...Since the peak day in 1988, the Alaskan oil fields have been producing about 5 percent less every year. Technology is getting better at sucking oil out of the ground but there's less oil to suck out. The problem is this: because there is less oil, as it flows across the state, it now cools. As it cools, it deposits wax on the side of pipeline wall, which makes inspecting hard. The water that's naturally in the oil drops out of solution and forms a little river on the bottom of the pipeline, which makes corrosion problems even greater than before. Below a certain level, things are going to be critical. The pipeline has come pretty close at least once to turning into what they call a giant popsicle (when the oil cools and gels). If that ever happens, it's the end of the pipeline that cost 10 billion dollars to build and many more hundreds of millions to maintain and repair it..."

Jonathan Waldman, Author (April 2015)

RE: the cost to build TAPS was actually \$7.7 billion (according to APSC), not \$10 billion

419



"...For example, Alyeska, owned by BP, Conoco Phillips, ExxonMobil and two smaller companies, used to launch devices to scrape wax - a component of the oil - out of the pipe's interior every several weeks. Now it's every four to seven days..."

Juneau Empire.com, January 4th 2010

Above: caption: "48-inch Trans-Alaska pipeline with pig on display"

420

"...While ice formation is not yet a problem in the trans-Alaska pipeline, it was the alleged cause of Prudhoe Bay's second-largest oil spill from a smaller pipeline a month ago. Alyeska officials said they don't know yet how soon they will need to make major upgrades to the trans-Alaska pipeline to deal with the colder oil temperature and how much it will cost. They hope to have some answers by the end of next year, when they conclude a \$10 million study of the problem..."

Juneau Empire.com, January 4th 2010

421

PIPELINE FACTS

- Length: 800 miles
- Diameter: 48 inches
- Crosses three mountain ranges and more than 500 rivers and streams
- Cost to build: \$8 billion in 1977, the largest privately funded construction project of that time
- Construction began March 27, 1975 and was completed May 31, 1977
- First oil moved through the pipeline June 26, 1977
- First tanker to carry crude oil from Valdez: ARCO Jureau, August 1, 1977

"...One thing they do know: New oil production from undeveloped oil prospects in the Arctic will not come on line soon enough to sidestep the problem. A damaged trans-Alaska pipeline would be big trouble for the state. The millions of barrels of oil that flow through it every week supply most of the tax revenue in the state's general fund and 10 percent of the country's oil production. It would be devastating for Alaska's private sector, which depends on the sustained flow of oil for thousands of jobs..."

Juneau Empire.com, January 4th 2010

422

"...The health of the pipeline is also critical to BP, Conoco and Exxon, which pour their North Slope oil output into it. They've funded millions for corrosion-related repairs and other upgrades to the pipeline since it was built in the 1970s. They recently funded the \$10 million project to study the reduced oil flow problem..."

Juneau Empire.com, January 4th 2010

423

On the Radar Screen

424

"...Alyeska has talked to the Joint Pipeline Office, a government agency, since the early 1990s about how declining oil flow could affect the pipeline, said Jerry Brossia, the agency's top federal regulator. 'It's always been on the radar screen,' Brossia said. The Joint Pipeline Office is composed of a dozen state and federal agencies that regulate the trans-Alaska pipeline..."

Juneau Empire.com, January 4th 2010

425

"...Among Alyeska's earlier projects to adapt to declining oil flow was its \$500 million project, finished this year, to replace the pumps that move the oil to Valdez. That project was plagued with cost overruns and other mishaps. The new pumps are now configured to work when the pipeline is transporting as little as 300,000 barrels per day. This year, the pipeline moved roughly 700,000 barrels per day, one-third of its peak flow in the late 1980s. Alyeska officials said they can prevent reduced oil flow from harming the pipeline but they conceded their research is taking them into uncharted territory. 'There's very little information elsewhere in the world on running pipelines in the Arctic at low temperatures,' said Mike Joynor, an Alyeska vice president involved in the \$10 million study..."

Juneau Empire.com, January 4th 2010

426

"...The company's inquiries led to a series of experiments that began last summer at an Imperial Oil-owned laboratory in Sarnia, Ontario, just north of Detroit. Imperial is a Canadian company partly owned by ExxonMobil. Exxon has a 20.3 percent stake in the Trans Alaska Pipeline System, or TAPS. The tests in Ontario involve running a couple different blends of North Slope crude oil through a series of pipe loops. In one loop, researchers working for Alyeska test the impact of cooling temperatures on wax suspended in the oil. In another, they test ice formation. The pipeline company is also running tests on crude oil at its offices in Valdez and at the pipeline pump station near Delta, said Alyeska spokeswoman Michelle Egan. Cooler oil is already causing headaches for the company..."

Juneau Empire.com, January 4th 2010

427

Cool Oil, Big Problem

428

"...Oil enters the pipeline at Prudhoe Bay at 110 degrees, but because it flows slower than in the past, the temperature drops quicker and remains below 70 degrees for much of its trip. When the oil temperature falls below 70, its wax content falls out. The wax will coat the pipe walls and hide corrosion if it isn't scraped out soon. Also, the wax can clog sensors on the large devices called smart pigs that shoot through the pipeline hunting for corrosion..."

Juneau Empire.com, January 4th 2010

429

"...Alyeska got a wake-up call on wax in 2006, during the partial shutdown of the Prudhoe Bay field after a major oil spill. The sensors on a smart pig launched into the pipeline became clogged with wax and it failed to collect data. Since then, Alyeska has been sending scraper pigs, another bullet-shaped device, down the pipe on a weekly basis. Alyeska officials believe they may see problems more worrisome than wax as soon as five years from now. They say that when the flow rate drops to only 500,000 barrels of oil a day, the oil temperature at certain points along the route north of Fairbanks could dip below 32 degrees. The small amount of water suspended in the oil could settle out and form ice crystals. Ice that coats pipe walls could create a hospitable spot for corrosion. Ice chunks that could form might batter pump-station equipment, regulators worry. Also, during a long pipeline shutdown, ice could plug sections of the line, making it difficult to restart the oil flow..."

Juneau Empire.com, January 4th 2010

430

Another Problem

431

"...Another problem might appear 15 to 20 years from now when the pipeline is projected to be moving just 300,000 or 350,000 barrels per day. At that point, the oil would no longer heat the ground around the buried sections of the pipeline enough to prevent the pipe from jacking up during frost heaves. While that is not expected to be a problem along the entire 400 miles of buried pipe, it would create too much strain on the pipe in certain areas, according to the company. Alyeska officials said they are optimistic that all of the bad consequences of lower oil flows can be avoided..."

Juneau Empire.com, January 4th 2010

432

“...The company is considering fixes such as heating up the oil, adding chemicals to prevent water from freezing or wax from clogging the pipeline, and removing the water suspended in the oil before the oil enters the pipeline, Joynor said. The fixes will likely be costly, but they are ‘at the heart of preserving the viability of TAPS,’ he said. If the company wants to proceed with any of those changes, it would need to get approval from state and federal regulators at the Joint Pipeline Office...”

Juneau Empire.com, January 4th 2010

433



“It all comes down to oil production, which is why they want to drill offshore in Alaska and why the (Arctic National Wildlife Refuge) and petroleum reserves are so contentious. It’s not like oil companies are hell-bent on getting Alaskan oil; it’s extremely difficult oil to get. But if there’s a pipeline to get that oil out, now is the time to get that oil. Without the pipeline, there’s no other way to get it...”

Jonathan Waldman, Author (April 2015)
Above: caption: “Alaskan Pipeline: Retired pig and pig in pipeline”

434

Part 8

Wild Alaska

435

The Biome Project

436

The Tundra

During the 6-10 week period of summer in the Tundra, temperatures can get as high as 50 degrees. The winter months are very long and dark. The temperature averages between -20 degrees and -30 degrees.

The tundra is very dry. Precipitation only totals about 8-10 inches every year.

Plants do not grow well in the Tundra because of the ground heat. It prevents roots from growing long and branching out.

The types of plants and animals that live in the tundra are low shrubs, mosses, and lichens.

Mixing and stirring are causing habitat loss to the animals that live in the Tundra.

Very few herbivores and omnivores are found here because of the lack of food.

Some Arctic Fish-eaters are... Strong winds, low rainfall, poor soil, short summer, and a very long cold winter.

The Tundra is in the high northern latitudes and high elevations of the world.

The Tundra is located in northern Alaska and is mostly surrounded by the North Pole.

International Biological Programme (Le Programme Biologique International)

Canada 6

“...By far the most complex, expensive part of the study is the United States’ \$1-million Tundra Biome project. Sponsored by the National Science Foundation, it is part of the broader, five-year, 11-nation International Biological Program, a wide-ranging scientific exploration in both polar regions...”

Popular Science, January 1973

Above: caption: “Canada’s Participation in the International Biological Program, 1967-1972”

437

MAJOR BIOMES OF THE WORLD

- Tundra
- Northern Conifer Forest (Taiga)
- Tropical Rain Forest
- Tropical Deciduous Forest
- Temperate Deciduous & Rain Forest
- Mountains
- Desert
- Chaparral
- Tropical Grassland & Savanna
- Temperate Grassland
- Tropical Scrub Forest

“...Tundra and its underlying, permanently frozen mat called permafrost have been little understood and little understood for many years, despite the fact that it covers 3,000,000 square miles of the earth, or about 1/20 of its total surface...”

Popular Science, January 1973

438

"... 'North Slope Tundra,' a veteran Alaskan oil man told me, 'is like a blank piece of paper. What's written on it stays written. Destroyed, tundra takes up to 40 years to regenerate.' To illustrate, he described how a small ditch was cut not many years ago to drain a lake. 'Today that ditch is 150 feet wide - and still widening,' he said. Environmentalists feared that pipeline activity would disrupt tundra ecology beyond redemption..."

Popular Science, January 1973

439

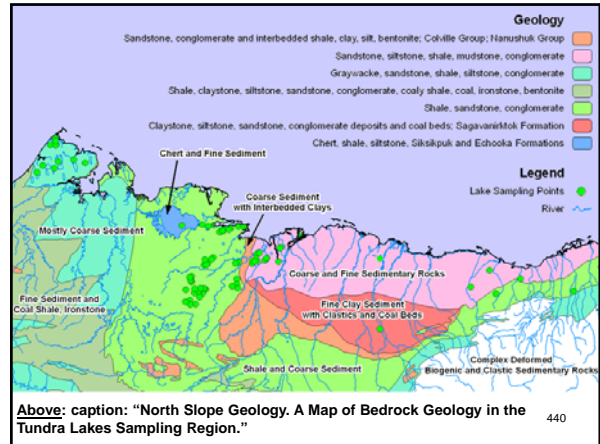

440



"...To determine if it would, Biome scientists set up experimental stations near Point Barrow. Some sections of the tundra they plucked bare (as grazing caribou might). They doused other areas with toxic substances. They buried heat sensors in some and spread fertilizers on still others. To determine how the pipeline will affect tundra vegetation, Alyeska then punched 3,000 test holes to sample the soil underneath. The conclusion: Half of the pipeline could safely be buried, the rest elevated..."

Popular Science, January 1973

Left: caption: "North Slope Tundra Polygons, North Slope, AK"

Middle: caption: "Tundra Landscape on North Slope of ANWR"

Right: caption: "Aerial photo of North Slope Tundra"

441



442



"...Because no one could predict which plants, if any, might be affected directly above the pipeline, a full-scale, 600-foot section was buried in permafrost at the University of Alaska's Fairbanks campus. Sensors fed into computers data on such areas as heat transfer and dissipation. Heated to 140 degrees, the test section accurately simulated the real pipeline. After two typical growing seasons and two severe winters, many plants have shown an ability to go dormant and revive..."

Popular Science, January 1973

443



"...Although the Biome project will continue until 1974, scientists have agreed on one preliminary conclusion: Despite its fragile nature, tundra has an amazing capacity to resist man's damage, and to recover..."

Popular Science, January 1973

444

Above: caption: "Pipe is wrapped and placed in trench during TAPS construction"



445

The Search Is On

446

"...Simultaneously, Alyeska and cooperating groups launched a worldwide hunt for plants capable of prospering in the state's varied soils. Seeds from other Arctic regions - Siberia, Finland, Canada - were tested. These would be used in replanting areas bared by construction..."
 Popular Science, January 1973

447

Fish 'Gotta Swim

448

"...To allay environmentalist's fears that extraction of gravel from wilderness streams for pipeline construction would harm fish, extensive ichthyological studies were begun...What resulted was the first complete fish inventory in Alaska history..."
 Popular Science, January 1973

449

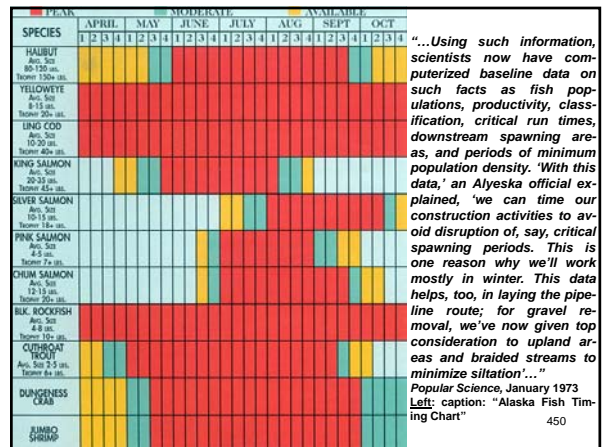



451

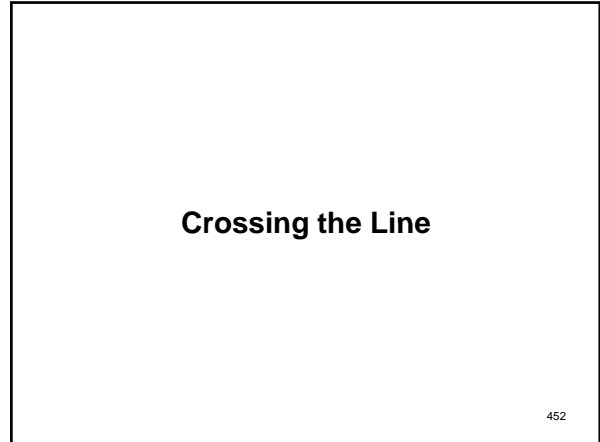

Crossing the Line

452

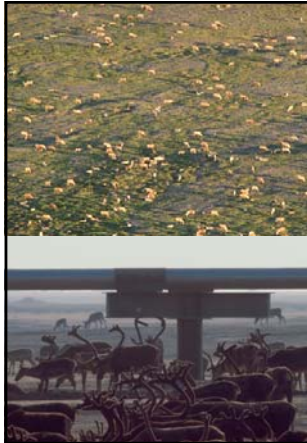

"...Migration habits of Alaskan wildlife, notably the state's 400,000 caribou, have undergone similar study. To determine whether caribou will cross the pipeline (conservationists feared they would not) Alyeska built a two-mile section of four-foot fence near Prudhoe Bay, resembling the pipeline in appearance. In some places, dirt ramps were built over the mockup; at other spots, the line was elevated on trestles to allow caribou to pass underneath..."

Popular Science, Jan. 1973 453



"...Scientists waited in blinds with cameras to record the results. Their conclusion: Caribou cross the lines, paying little heed to man's activity nearby..."

Popular Science, January 1973 454

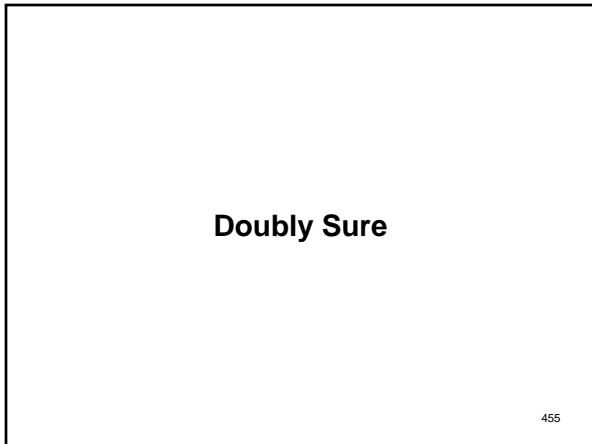

Doubly Sure

455



"...To make doubly sure that the animals wouldn't be interfered with, Alyeska engineers used the impact-study data in considering routing for the line. For example in one section of the imposing Brooks Range, which an estimated 30,000 to 40,000 caribou traverse in their annual migration, the line will be buried entirely. After a study of Dall sheep in the Brooks Range, sponsored jointly by the Alaska Fish and Game Department and University of Alaska biologists, Alyeska changed its planned route to avoid disturbance..."

Popular Science, January 1973 456
Above: caption: "Alaskan Dall Sheep"



457

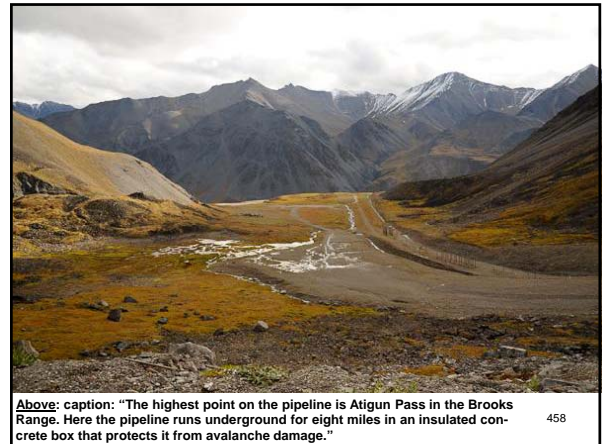

Above: caption: "The highest point on the pipeline is Atigun Pass in the Brooks Range. Here the pipeline runs underground for eight miles in an insulated concrete box that protects it from avalanche damage."

458

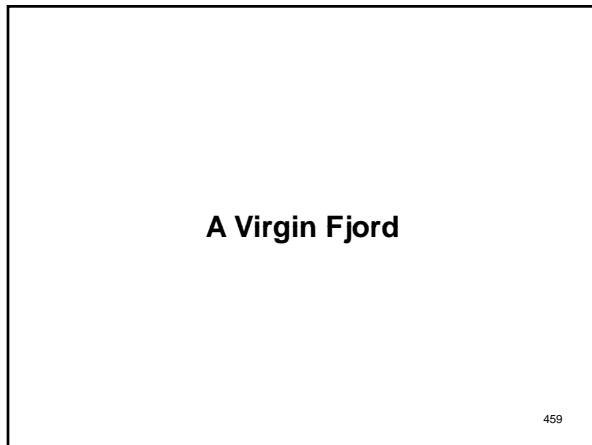

459

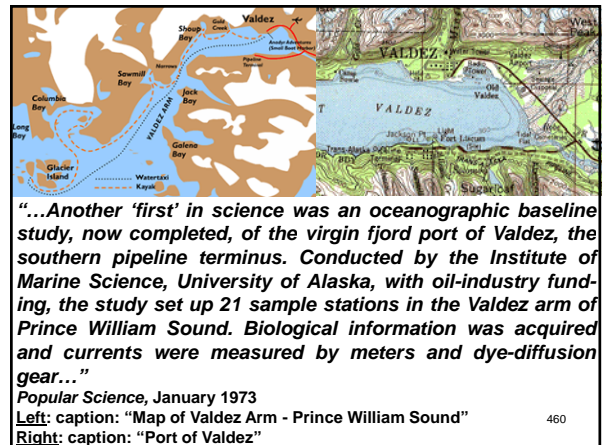

"...Another 'first' in science was an oceanographic baseline study, now completed, of the virgin fjord port of Valdez, the southern pipeline terminus. Conducted by the Institute of Marine Science, University of Alaska, with oil-industry funding, the study set up 21 sample stations in the Valdez arm of Prince William Sound. Biological information was acquired and currents were measured by meters and dye-diffusion gear..."

Popular Science, January 1973
Left: caption: "Map of Valdez Arm - Prince William Sound"
Right: caption: "Port of Valdez"

460



461

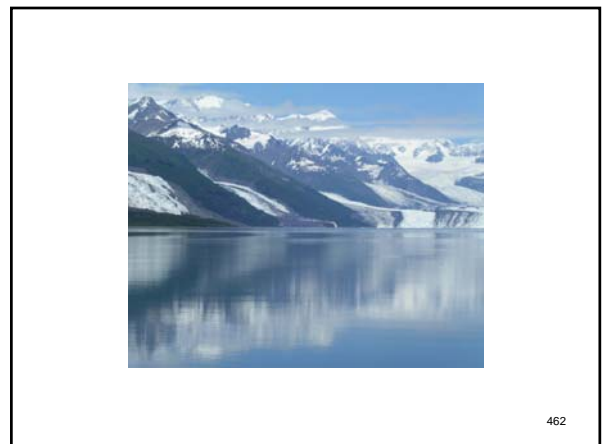

462

Coastal Plain Estuary
River Delta
Estuary

Tectonic Estuary
Faults
Estuary

Bar-Built Estuary
Sand Spit
Estuary

Fjord
Steep Walls
Fjord

“...The study indicated that Valdez is a classic example of a ‘positive fjord estuary’; more fresh water enters the harbor through runoff than is lost by evaporation. The harbor thus renews itself at least once a year...”
Popular Science, January 1973

Left: Caption: “There are four main types of estuaries: coastal plain, tectonic, bar built and fjords. Estuaries make great tourism attractions and/or harbors and ports. The mix of fresh and saltwater makes a great feeding ground and habitat for many types of wildlife. This water mixture also results in a mixture of types of sediment. Though estuaries have sediment from both upstream rivers and from the ocean, most of the sediment is relatively fine grained. Too much sediment makes it hard for plants to photosynthesis and limits human use of the estuary since sediment can be deposited, making the estuary unsuitable for ship traffic. If there is too little sediment in the estuary then the land bordering it may be eroded away and increase predation rates in some species.” 463

(a) Coastal plain (b) Fjord
(c) Bar-built (d) Tectonic

Above: caption: “Coastal plain estuaries form from the rise of sea level. They rising sea level then fills an already existing river valley with water, creating an estuary. Tectonic estuaries form on faults, where tectonic activity has created a space that can be filled in with water. The San Francisco Bay is an example of a tectonic estuary. Bar built estuaries are behind some sort of natural bar between the estuary and the ocean, such as a spit. Fjords are valleys that were, at one time, carved out by glaciers and were then filled in with water.” 464

KEY
Fresh Water
Brackish Water
Sea Water
Hypersaline Water

465

A Biological Yardstick

466

“...Environmentalists had charged that an oil spill in the harbor would cause potential danger to marine life. Without the baselines data, biologists studying such a spill would have no biological ‘yardstick’...”
Popular Science, January 1973

467

468

A State Transected

469

"... 'Never before has anyone been able to cut a transection of an entire state.' beams Michael Kennedy, curator of the Alaska State Museum in Juneau. 'We're tremendously excited about it'..."
Popular Science, January 1973

470

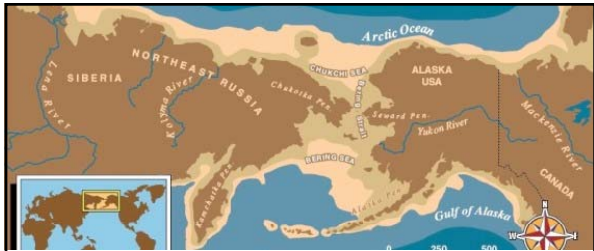

"...In two years archaeologists have found 189 sites. The information is particularly significant because the Alaskan interior was a key entrance to the New World from Asia 50,000 to 60,000 years ago..."
Popular Science, January 1973
Above: caption: "During the last Ice Age many thousands of years ago, the ocean level dropped to expose an un-glaciated, ancient land known as Beringia. Up to 1,000 miles wide, the grass-covered land mass connected Asia to North America."
 471

As Below, So Above

472



"...Alaskan birds were also studied; one survey counted 171 species of waterfowl alone. At Cook Inlet, a graduate student expert in seabirds is currently defining the ecology of a kittiwake colony on Chisik Island. Another ecologist is studying falcons on the North Slope, near the oil fields. Yet another learned that Alyeska had planned a communications station near a nesting site of rare peregrine falcons. Based on his information, the site was moved..."
Popular Science, January 1973
 473

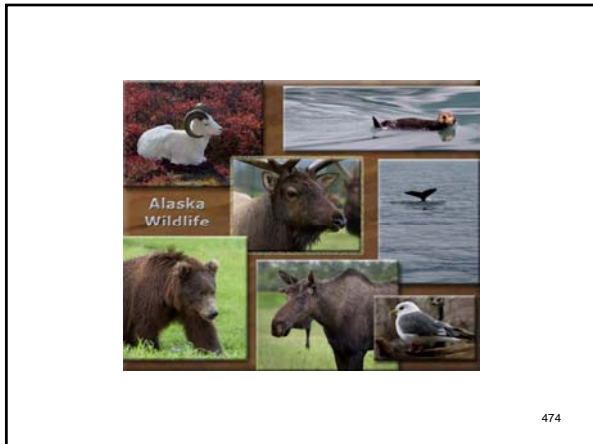

474

Tangential Benefits

475

“...Some other results of the impact-study program...”
Popular Science, January 1973

476

“...Seismologists determined that the pipeline route lies near four major fault zones and directly crosses a fifth, the Denali. Now, knowing this, Alyeska has agreed to establish an instrumented earthquake ‘warning system’ along the route. Based on data compiled by the U.S. National Center for Earthquake Research, Alyeska will install creep meters and seismometers at given intervals. These, seismologists say, are useful in detecting minor tremblors which often precede major shakes. If such a major quake seems imminent, the oil flow will be shut down immediately...”

Popular Science, January 1973

RE: where the Denali Fault crosses TAPS, dislocation occurred along a series of “en echelon” fissures as a result of the M7.9 Denali Fault Earthquake which occurred on November 3rd 2002. One of these en echelon breaks intersected the end of one of the Teflon surfaced skids (sleepers) that supports the pipe in the fault zone, displacing it about a meter but not damaging the pipe. Strong shaking and movement of the pipe resulted in damage to eight horizontal support members, and nine anchored supports near the fault crossing. These affects were not critical to the integrity of the pipeline, which performed well during the event.

477



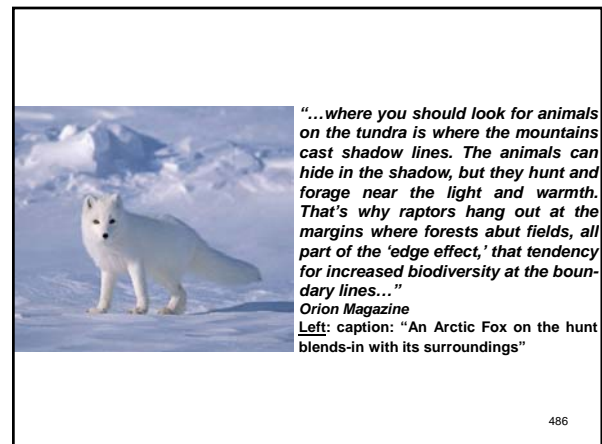
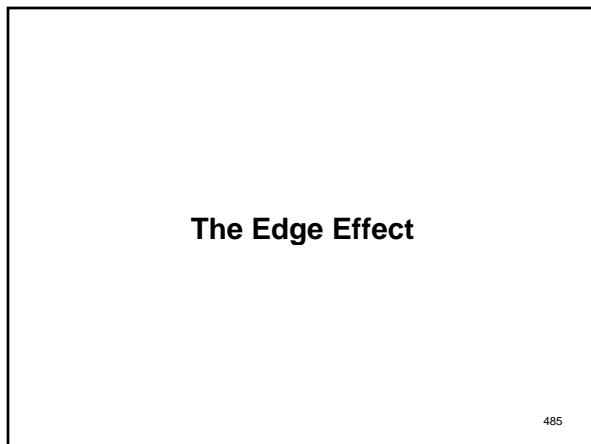
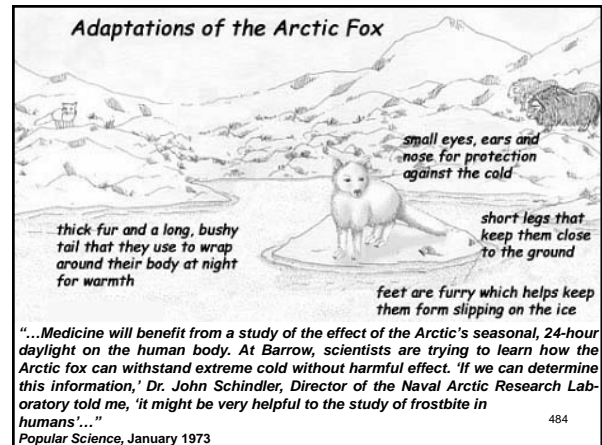
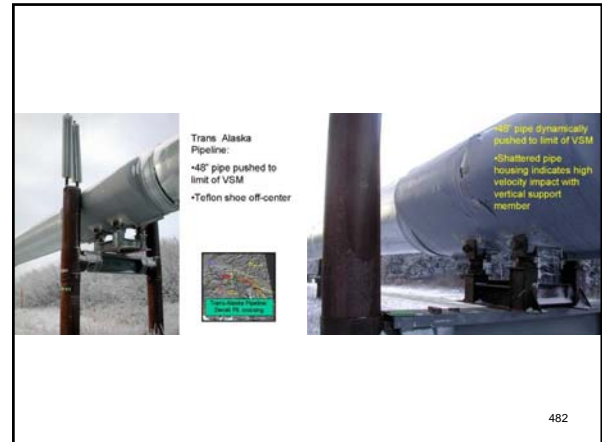

An Oil-Boom Spin-Off

487

"...Not all the studies, of course, were financed by oil interests, and not all directly involved the pipeline. 'But the oil-boom spin-off,' an Anchorage business man told me, 'sure helped us learn a lot more about ourselves, and about our state...'"

Popular Science, January 1973

488

A Calculated Risk

489

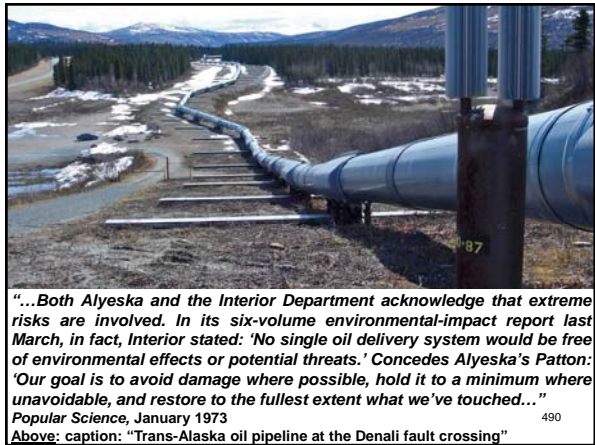

The Buck Stops There

491

"...Last August, after the impact study had been submitted by the Interior Department, federal judge George Hart lifted the injunction blocking construction. Apparently expecting an appeal by environmentalists, however, he said he could 'confidently anticipate the final decision rests with the Supreme Court'..."

Popular Science, January 1973

492

Alyeska in Low Gear

493

“...To date, permits have not been issued for pipeline construction to begin. Alyeska remains in low gear: construction camps emptied of all but skeleton crews, production wells capped off...”

Popular Science, January 1973

Left: caption: “A map of the Trans-Alaska Pipeline with pump stations and construction camps identified.” APSC had 12 pipeline construction camps either built or under construction by 1974. However, these camps were all north of the *Yukon River* and camps had to be built along the entire length of the project. APSC planned for 29 construction camps (31 were built). Seven were built along the pipeline south of the Yukon and one at each of the twelve pump stations. The camps were built on thick beds of gravel laid down to insulate the underlying permafrost and to prevent environmental pollution. At the conclusion of construction, the gravel was removed. Construction headquarters was at *Fort Wainwright* (near Fairbanks) where APSC leased land and buildings from the U.S. Army.



“The biggest thing was the logistics. Getting all that stuff and the materials and the ability to sustain 10,000 people working in a place where no one has worked before. And there was no infrastructure - that was the big deal.”

Bill Howitt, APSC Engineer

RE: in October 1977, TAPS was fully staffed with 28,062 workers and contractors. In the three years it took to build the pipeline, more than 70K people were employed in one way or another. Organizing the work force, providing equipment, transportation etc. and providing food and shelter for all these people one of the most difficult tasks for APSC. Many workers lived in camps set-up along the pipeline route. The pipeline camps ranged from 250-person sites at the pump stations to the 3,500-person terminal camp at Valdez. What most remember about the camps was the abundance of food (all-you-could-eat), party atmosphere and the alcohol and drugs (the camps were basically self-governing, without any type of law enforcement). Among the workers, the joke was that you could tell what union someone belonged to by their “drug-of-choice” (i.e. Operating Engineers preferred alcohol, Teamsters favored cocaine and Laborers chose marijuana).

495

A Snowmobile in Every Garage

496

“Suddenly people started coming in to town. It happened kind of rapidly when it took off. Because I don't think anybody really believed this monstrous project was going to impact us. I mean, maybe the politicians did, but I think the average guy was just kind of going, ‘Oh sure, we've heard this before,’ because this has always been a boom or bust town. And suddenly, there it was. It was like a circus every night. People coming in to town with \$3,000, \$4,000, \$5,000 cash in their pockets. Suddenly women that we'd never seen before were appearing from places like Florida and New York. It was like night and day.”

J.B. Carnahan, Fairbanks (AK) Police Officer

RE: by 1976, Fairbanks had doubled in size; to 40K people. Rents quadrupled. Many who had no connection to the local unions had to wait months to get a job (often requiring a pay-off to a union official).

497

When TAPS was in its startup/mobilization stages, Fairbanks was a sleepy town in Alaska's interior (it had only two policemen). Suddenly, it became a boomtown akin to Alaska's “Gold Rush” days. Fairbanks was now filled with lots of people with lots of cash to burn. People were arriving from the lower 48 states, driving up through Canada on the *Alaska* (a/k/a “ALCAN”) Highway. Welders and truckers came from Oklahoma and Texas. Secretaries, teachers, cooks (along with prostitutes and their pimps) came looking for opportunities - and found them. From as far a-field as South America and Ireland, men (and women) came seeking something they couldn't find at home. Most for money, others for the adventure of starting a new life in an untamed wilderness.

Top: caption: “Pipeline worker with weekly paycheck”

Bottom: caption: “Pipeline workers on a bus”



"In many ways, the pipeline is like an iceberg. What you see with your eyes is only a fraction of what is really there. The real threat to the Alaskan wilderness and lifestyle is the part of the pipeline you cannot see: the money, the people and, most of all, the boom-town mentality that has permeated Alaskan society - a warm, modern house, a steady job and two snowmobiles in every garage."

Ron Rau, TAPS Workman and Freelance Writer (1976)

RE: the most visible effects of the pipeline were social and economic. The project, at its peak, created jobs for 21K workers, most of whom came in from outside the state. Thousands more flocked to Alaska hoping to find high-paying jobs on the pipeline but often ended up broke and stranded. The population of Fairbanks - the main staging area for the project, increased by more than 25%, while that of Valdez more than quadrupled.

499

Boomerang Effect

500

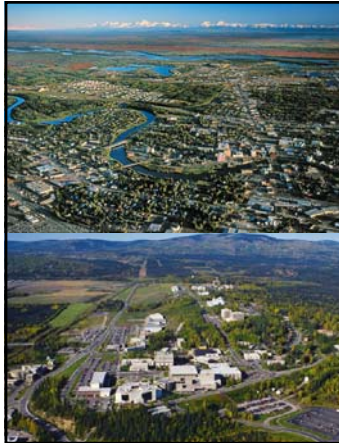

"This is no boom. It's a boomerang."

Sylvia Ringstadt, Mayor of Fairbanks, AK

RE: the sudden spurt in development also had some more serious side effects: increases in crime, prostitution, gambling, alcoholism, venereal disease, divorce and child neglect. Fairbanks also suffered housing shortages, traffic congestion, overburdened city services, crowded schools and rampant inflation. More than any other place, Fairbanks felt the "boom-bust" effects of TAPS.

Top: caption: "Aerial view of the Chena river winding through downtown Fairbanks, AK. Mountain Range across the Tanana Valley Flats, AK."

Bottom: caption: "Aerial view of the U. of Alaska at Fairbanks" 501

Border Wars

502

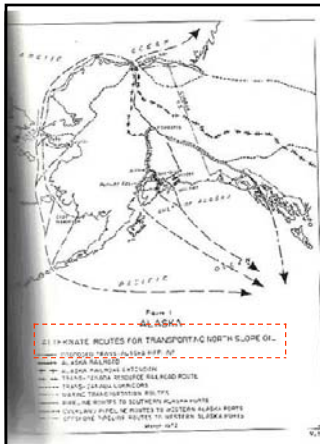

"...Some environmentalists are pushing for adoption of a trans-Canada route that would enter the mid-western U.S. through Alberta. Such a line would be four times the length of the Alaska pipeline and about double the cost. Some Canadian officials have expressed interest in the trans-Canada proposal, but observers believe the political conflict that might result from such a project - as well as opposition from the oil companies - will prevent a Canadian line for Alaskan oil..."

Popular Science, January 1973

Left: caption: "A map of suggested oil routes through various means of transportation. Federal Task Force on Alaskan Oil Development - Final Environmental Impact Statement, Dept. of the Interior, 1972" 503

Technology and Pressure

504

“...Whatever further delays might occur, however, it has been suggested that the outcome already has been a victory for the environmentalists. It was Dr. Schindler, Navy Arctic lab director and a veteran biologist, who perhaps summed it up best. ‘What we’ve gained from the impact study has been massive,’ he told me. ‘I have many reservations about the pipeline, but industry technology - and environmental pressure - has overcome many hazards that loomed at first’...”

Popular Science, January 1973

505

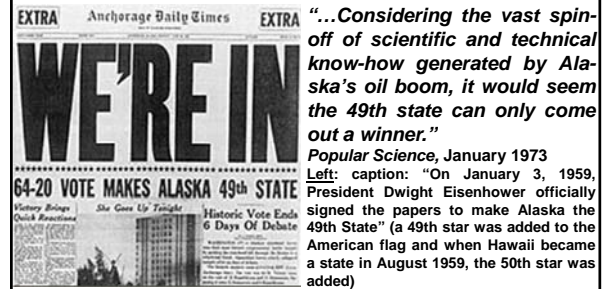

506

When President Eisenhower signed the *Statehood Act* (making Alaska the 49th State of the Union, in January 1959), the legal power of Alaskans to control their own destiny expanded exponentially. Prior to statehood, the influence of the Federal Government had been disproportionately great. Between 1902 and 1926 the Federal Government had set aside 54 million acres as national parks and wildlife refuges. All the rest was potentially subject to Native title. However, Congress had never made any treaties with Alaska’s Native Americans. The Statehood Act granted Alaskans 103 million acres (out of 375 million acres) of land. Even with statehood, the Federal Government’s influence would remain significant. Not surprising considering the fact that most employment/income (civil and military) of its residents was derived through the Federal Government.

507

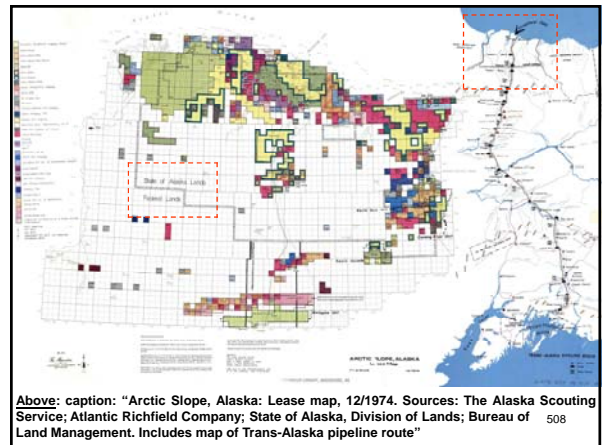

508

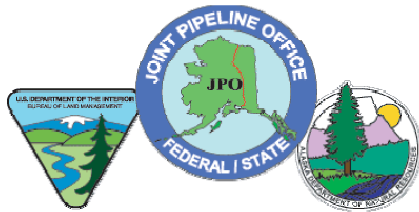

Concerning TAPS, this new Federal-State power relationship had two dynamics:

- The Federal Government would exert great influence in authorizing TAPS in the establishment of rules/guidelines that would govern its design, construction, inspection etc. as well as employment practices;
- The State of Alaska would also exert authority over the project.

As a result, APSC would face contradictory pressures/demands since State and Federal interests sometimes differed. Very often, there was duplication concerning oversight controls and/or reporting requirements, often resulting in conflict, delays and cost overruns.

509

The Art of the Deal

510

“Suddenly in the 1960s, you saw this powerful convergence of forces that all had to do with land, the state’s ability to select up to 103 million acres of land under the Statehood Act, the discovery of oil, powerful economic forces at work to bring the oil to market. And it became clear to the Native Alaska community that if it were going to have any chance at all of settling their claims to land in Alaska that community had to get active, and get active very quickly.”

Byron Mallott, Native Leader - First Alaska Institute

RE: by December 1966, native leaders formed the *Alaska Federation of Natives*, the first statewide organization to advocate for a native land claims settlement. In some of the early discussions, the Federal Government offered less than \$100 million and no land. In 1968, with the discovery of oil on state-owned land in the *Arctic Circle*, native leaders felt it was now or never to make a settlement. Suddenly, the stakes were a lot higher.

511

“It was all about the economic value of oil and they needed to remove this potential roadblock”

Byron Mallott, Native Leader - First Alaska Institute

RE: on March 9th 1970, five native villages filed suit against both the oil companies and the *U.S. Department of Interior*, which was poised to grant a construction permit to APSC. Of the two suits, one was against Interior Secretary *Walter J. Hickel* (former Alaska Governor) to stop the building until natives along the pipeline gave consent. The second suit, filed in State Court, claimed that oil companies had failed to honor a contract to hire native contractors and workers for the pipeline project. On April 3rd 1971, Federal District Court Judge *George L. Hart* issued a preliminary injunction to stop the DOI from permitting construction of a road that would cross land claimed by the sixty-six residents of *Stevens Village* near the *Yukon River*. It was a major blow for APSC, but a significant victory and a landmark case for Alaskan native Americans. The State and Federal Government/s would have to settle land claims with Alaskan natives if they wanted to make TAPS a reality. For several months, the two sides worked diligently on a deal that would be acceptable to all concerned parties.

512

“It was certainly a unique deal. There’s no question that the Alaska Native Claims Settlement Act at the time was just unprecedented”

Byron Mallott, Native Leader - First Alaska Institute

RE: in the end, the dispute was resolved and on December 18th 1971, POTUS *Richard M. Nixon* signed into law the *Alaska Native Land Claim Settlement Act*. The law gave Alaska natives 44 million acres of land and \$962.5 million (half of the money was to be paid from royalties from oil production).

513



514

Part 9

JFWAT

515

CONSTRUCTION-RELATED IMPACTS OF THE TRANS-ALASKA PIPELINE SYSTEM ON TERRESTRIAL WILDLIFE HABITATS

AUGUST 1979



Joint State/Federal Fish & Wildlife Advisory Team

In 1974 the Joint State/Federal Fish and Wildlife Advisory Team (JFWAT) was organized to monitor the construction of the Trans-Alaska Pipeline System (TAPS). JFWAT was disbanded in December, 1977 after TAPS construction and major restoration activities were completed. During this period (1975 to 1977), JFWAT conducted a terrestrial habitat evaluation to determine the impacts of TAPS construction on terrestrial wildlife habitats. Most of the basic data for this evaluation was obtained prior to JFWAT’s disbandment. Final data compilation and data analysis were completed in 1978 after the author returned to regular duties with the U.S. Fish and Wildlife Service (FWS).

516

Abstract

517

The Joint State/Federal Fish and Wildlife Advisory Team (JFWAT) conducted a terrestrial habitat evaluation of the 800-mile Trans-Alaska Pipeline System (TAPS). The purposes of this project were to identify and evaluate wildlife habitats along the TAPS and determine the quantitative and qualitative impacts of TAPS construction on these habitats. Using a classification system consisting of twelve habitat types, the study area (about 2,150 square miles) was cover typed on pre-construction aerial imagery. Post-construction imagery of the same scale was used to determine the surface area impacts. Approximately 31,403 acres of terrestrial wildlife habitat were altered or destroyed by construction activities as of July, 1976.

518

Background

519

In 1968 oil was discovered at Prudhoe Bay on Alaska's Arctic Coastal Plain. The following year several oil companies applied for state permits and a Bureau of Land Management (BLM) right-of-way permit to construct a pipeline across state and federal lands in Alaska. The federal government was temporarily stopped from issuing the permit due to legal suits filed by national environmental organizations. Litigation evolved around the requirements of the National Environmental Policy Act of 1969 and the Mineral Leasing Act of 1920. A final environmental impact statement was issued by the Secretary of Interior in March, 1972 (U.S. Dept. Int. 1972). In November, 1973, Congress passed Public Law 93-153 (Trans-Alaska Pipeline Authorization Act) which, among other things, amended the Mineral Leasing Act so that a BLM permit could then be issued for pipeline construction which required an increased right-of-way width.

520

In early 1974, a consortium of seven major oil companies (Amerada Hess Corp., ARCO Pipeline Co., Exxon Pipeline Co., Mobil Alaska Pipeline Co., Phillips Petroleum Co., Sohio Pipeline Co., and Union Alaska Pipeline Co.) signed agreements and grants of right-of-way with both the United States of America (U.S. Dept. Int. 1974) and the State of Alaska. With the major legal requirements resolved, the aforementioned companies designated Alyeska Pipeline Service Company (APSC) to function as the Permittee for construction, operation, maintenance, and termination of the Trans-Alaska Pipeline System (TAPS). APSC thus became the oil industry's agent responsible for ensuring that the provisions (e.g. environmental and technical stipulations) contained in the federal and state agreements and grants of right-of-way would be followed. Certain other requirements also were mandated. For example, the Permittee through its Quality Assurance Program was to ensure that impacts to fish and wildlife resources were minimized during the construction, operation, maintenance, and termination of the TAPS (U.S. Dept. Int. 1974).

521

In Section 13 of the Agreement and Grant of Right-of-Way for Trans-Alaska Pipeline between the federal government and the Permittees (U.S. Dept. Int. 1974), a requirement was set forth such that the Permittees:

"(2) shall rehabilitate (including but not limited to, revegetation, restocking fish or other wildlife populations and re-establishing their habitats), to the written satisfaction of the Authorized Officer, any natural resource that shall be seriously damaged or destroyed, if the immediate cause of the damage or destruction arises out of, is connected with, or results from, the construction, operation, maintenance or termination of all or any part of the Pipeline System."

The above requirements may appear stringent; however, it should be remembered that the TAPS project was controversial and unprecedented in Alaska's arctic and sub-arctic environments. There was, and continues to be, a great potential for serious and long-term environmental damage.

522

Prior to TAPS, the concepts of mitigation (i.e. lessening impacts) and compensation (i.e. replacing or reestablishing) of altered and destroyed fish and wildlife habitats had been established nationwide. These principles have been applied to federally funded and permitted water-related development projects. In the past decade, the American public has demanded that fish and wildlife values receive adequate protection when threatened by major development projects.

523

The terms and conditions of the state and federal right-of-way agreements (e.g. environmental and technical stipulations) provided the mechanisms to protect public fish and wildlife resources. Enforcement of the stipulations was the primary vehicle for ensuring that unnecessary and avoidable adverse impacts were minimized during construction. However, regardless of the degree of environmental stipulation compliance by APSC, it was inevitable that unavoidable and, in many instances, irreparable damages would occur to fish and wildlife habitats.

524

Construction of the TAPS started in the spring of 1974. The Joint State/Federal Fish and Wildlife Advisory Team (JFWAT) was organized during this same time period, under the authority of Section II, Paragraph 6 of the Cooperative Agreement between the United States Department of the Interior and the State of Alaska regarding the proposed trans-Alaska Pipeline (U.S. Dept. Int. 1974). JFWAT was not fully staffed for field monitoring until late fall 1974. The purpose of JFWAT was to function as a single interagency team of professional biologists who would provide for the protection of fish and wildlife resources by cooperative effort over the length of the pipeline on both state and federal lands. Biologists from the Alaska Department of Fish and Game (ADF&G), BLM, National Marine Fisheries Service (NMFS), and U.S. Fish and Wildlife Service (FWS) participated in this joint effort.

525

JFWAT functioned as a line component of both the federal government's Alaska Pipeline Office (APO) and the State Pipeline Coordinator's Office (SPCO) and coordinated many of the pipeline-related statutory and regulatory responsibilities of the cooperating resource agencies. The primary objective of JFWAT was to ensure that the construction and future operation of the TAPS caused only minimal adverse impacts, both short and long-term, to fish and wildlife populations and their habitats.

526

APO and SPCO were responsible for enforcing the right-of-way agreements and stipulations on federal and state lands. JFWAT recommendations and field advices were given to the appropriate offices and field representatives of APO and SPCO and pertained to the following items:

- (1) design review of technical documents, change orders, contingency plans, and permit applications submitted by APSC;*
- (2) the Permittee's compliance with environmental stipulations during the construction phase of the project, and;*
- (3) determination if as-built structures for fish and wildlife protection and utilization were constructed according to approved designs and specifications.*

527

After being directly involved with continuous surveillance of pipeline construction activities for more than a year, JFWAT recognized the need for an overall documentation of TAPS construction impacts on fish and wildlife habitats. To fulfill this need, JFWAT conducted two broad evaluations: one concerned with terrestrial wildlife habitats and one with fish stream habitats. This report pertains only to the former evaluation.

528

The objectives of JFWAT's terrestrial habitat evaluation were:

- (1) identify and evaluate the major wildlife habitats along the TAPS;
- (2) determine quantitative and qualitative impacts of TAPS construction on terrestrial wildlife habitats;
- (3) provide baseline information for future evaluations of long-term habitat alterations caused by developments associated with the TAPS;
- (4) provide information and recommendations applicable to future construction projects in sub-arctic and arctic environments.

529

Study Area

530

TAPS Construction Sections

Indicated below are the construction section (Const. Sec.) divisions of the TAPS as used in JFWAT's terrestrial habitat evaluation.

Const. Sec. 1	- Valdez Terminal (A.S. 1)	to	Sourdough (A.S. 28)
Const. Sec. 2	- Sourdough (A.S. 28)	to	Salcha River (A.S. 53)
Const. Sec. 3	- Salcha River (A.S. 53)	to	Yukon River (A.S. 77)
Const. Sec. 4	- Yukon River (A.S. 78)	to	Stamm (A.S. 100)
Const. Sec. 5	- Stamm (A.S. 100)	to	Pump Station 4 (A.S. 124)
Const. Sec. 6	- Pump Station 4 (A.S. 124)	to	Pump Station 1 (A.S. 138)

(A.S. = TAPS Alignment Sheet Number)



The study area, about 2,150 square miles, encompassed lands directly affected by the TAPS from Pump Station 1 (Plate 27), approximately four miles south of Prudhoe Bay on the Beaufort Sea, to the Valdez Terminal (Plate 23) located on the south shore of Valdez Arm in Prince William Sound (Figure 2, left). This is a distance of approximately 800 miles with an average width of about 2.5 miles. The 358 mile-long Yukon River-Prudhoe Bay Haul Road (hereafter termed "Haul Road") (Plates 15 & 16) also was included except for a short section south of Pump Station 1.

531



Top: caption: "Plate 27. Pump Station 1 built in wet-meadow tundra (HQ) about four miles south of Prudhoe Bay in A.S. 138, Section 6. View is northwest. A lake of approximately 140 surface acres in size was drained so that this pump station could be constructed. July, 1977."

Bottom: caption: "Plate 23. The Valdez Terminal, constructed in coastal forest (MQ) and shrub thickets (HMQ), adjacent to Valdez Arm in Prince William Sound. Oil storage tanks can be seen on the uplands with loading docks for the oil tankers extending into saltwater. June, 1976."

532



Top: caption: "Plate 15. A portion of the Haul Road constructed through spruce-deciduous woodland (HMQ) in A.S. 97, Section 4. View is north. Note new growth on the cut and fill slopes from revegetation with grasses. June, 1977."

Bottom: caption: "Plate 16. A portion of the Haul Road through wet-meadow tundra (HQ) in A.S. 130, Section 6. View is north. The narrow line of ditch spoil paralleling the Haul Road on the west side is from the burial of a natural gas, fuel line which runs from Pump Station 1 to Pump Station 4. July 1977."

533

The study area did not include the Prudhoe Bay oil and gas fields and related developments. A few TAPS-related developments were located outside the study area as determined by the availability of aerial imagery. These included a portion of Galbraith Camp (Alignment Sheet [A.S.] 114) and its associated access road, material site (M.S.) 114A-2, Isabel Camp (A.S. 34), and the 56 mile-long TAPS road (now called the Yukon Highway).

534

The TAPS traverses eight of twelve physiographic provinces of Alaska. The Brooks Range, the Alaska Range, and the Chugach Mountains are crossed. The TAPS north of the Brooks Range lies in the zone of continuous permafrost. From the south slope of the Brooks Range through the interior of Alaska, the TAPS is in an area of discontinuous permafrost. Sub-surface ice bodies and ice-rich soils are widely distributed in these northern and interior regions. After crossing the Chugach Mountains through Thompson Pass, permafrost in the study area is sporadic or nonexistent (Wahrhaftig 1965).

535

Over 600 streams are affected by the TAPS with nearly 400 documented as fish streams. Some major drainage systems crossed by the oil pipeline are the Sagavanirktok, Yukon, Tanana, Gulkana, Tonsina, and Lowe Rivers. Multiple crossings occur in several rivers (e.g. Sagavanirktok, Atigun, Dietrich, Middle Fork Koyukuk, Little Tonsina, and Tsina). Ponds and lakes are prevalent in many portions of the study area. The TAPS spans a wide range of climatic conditions. Average annual precipitation ranges from less than eight (8) inches on the Arctic Coastal Plain to 12-16 inches in the interior to greater than 60 inches in the coastal area of Valdez. Mean annual temperatures vary from 10°F north of the Brooks Range, 25°F in the interior, and 34°F in the southern portion. The entire TAPS is subject to periodic seismic activity with the greatest potential for earthquake-induced damages to occur in the interior and southern regions. The oil pipeline crosses the Denali Fault (A.S. 38) south of Lower Miller Creek in the Alaska Range.

536

Much of the study area (e.g. Brooks and Alaska Ranges and the Chugach Mountains) was glaciated during the late Pleistocene epoch (Wahrhaftig 1965). Today only a few small segments of the study area have glaciers which are in relatively close proximity to the TAPS. Most noteworthy are the Black Rapids Glacier in the Alaska Range (A.S. 39) and Worthington Glacier in the Chugach Mountains (A.S. 6). The oil pipeline passes within 700 yards of the latter.

537

A large portion of the study area was relatively un-developed before construction of the TAPS. Although road-less prior to 1974, the study area north of the Yukon River through the Brooks Range had experienced very limited exploitation and development...a small gold-mining settlement in the Brooks Range, still exists from the early 1900's. The largest communities intersected by the oil pipeline are Fairbanks, Delta Junction, and Glennallen. The pipeline terminal is located across Valdez Arm from the town of Valdez. The Richardson Highway parallels the TAPS from Valdez to Fairbanks.

538

*Vegetation in the study area changes considerably from north to south. The area north of the Brooks Range is tundra. The northernmost stand of trees in the study area is white spruce (*Picea glauca*) and is located south of the Continental Divide in the Brooks Range (A.S. 108). Boreal forests exist from the south slope of the Brooks Range through the interior. Coastal forests occur south of Thompson Pass in the Chugach Mountains (A.S. 5). Tree line generally occurs from 2,000 to 3,000 feet elevation. Alpine areas are present in all previously mentioned mountain ranges. Wetlands and shrub communities are found throughout the study area.*

539

Study Phases

540

Two study phases were conducted simultaneously in this evaluation. The "quantitative" phase concerned identification and delineation of wildlife habitats on pre-construction aerial photographs so that TAPS construction-related impacts could be quantified from post construction imagery. The "qualitative" phase involved an assessment of each habitat type in relation to its ability to provide the life-support requirements for selected wildlife families and species. Prior to the initiation of either phase, it was necessary to develop a habitat classification system based on vegetation parameters. Minor refinements of the classification system were made during the early stages of the quantitative phase to compensate for variations in image quality.

541

Habitat Classification

542

Time and manpower constraints associated with this evaluation necessitated the formulation of a habitat classification system which would be comprehensive in terms of applicability to the study area as well as expedient relative to implementation. A broad classification system was developed consisting of twelve basic types.

543

Coastal Forest (01)

In relation to the TAPS, this habitat type occurs only in those southernmost areas directly affected by maritime influences. The landscape is characterized by steep rough terrain, narrow valleys, and glacial outwash streams.

544



Above: caption: "Plate 1. Coastal Forest; Prince William Sound, Alaska."

545

Spruce-Deciduous Woodland (02)

Species diversity and abundance varies considerably in spruce deciduous woodland. Fires historically have had a significant influence on the successional patterns of this habitat type, hence seral communities are common.

546



Above: caption: "Plate 2. Spruce-Deciduous Woodland; near Bonanza Creek (A.S. 89) on south slope of the Brooks Range." 547

Spruce Woodland (03)
Spruce woodland normally is found on the drier uplands, oftentimes on south facing slopes. It also occurs in floodplains adjacent to streams where permafrost is nonexistent and drainage is good.



Above: caption: "Plate 3. Spruce Woodland; a few miles north of Dietrich Camp (A.S. 104) in the Brooks Range. Note two sleeping grizzly bears (Ursus arctos) in center of photo." 549

Wetlands (04)
This type encompasses a broad range of wetland communities to include bogs and marshes. It is characteristic of relatively flat areas with little relief, poor drainage, and ground surfaces oftentimes underlain by permafrost. Shallow standing or slow moving water is common. Saturated soil conditions sustain a predominance of aquatic vegetation.



Above: caption: "Plate 4. Wetlands; north of Glennallen in Section 1 (A.S. 22). Spruce woodland (03) surrounds this wetland area." 551

Shrub Thicket (05)
Shrub thickets commonly are interspersed with other major habitat types and frequently occur on recently exposed and periodically flooded alluvial deposits, along borders of ponds and meander scars, in steep ravines and old avalanche tracks, and in recently burned areas. The thickets are often extremely dense and species composition ranges from pure to mixed stands of tall shrubs with dense understories of low shrubs, herbs, mosses, and lichens.



Above: caption: "Plate 5. Shrub Thicket; looking east from pipeline (A.S. 103) to Sukakpak Mountain in the Brooks Range. Note access road from the Haul Road to a material site at base of mountain." 553

Riparian Willow (06)
Riparian willow habitats normally are associated with coarse gravel substrates of glacial and riverine floodplains, on coarse gravel bars of braided streams, and along small interior and arctic streams. The degree of intergradation of the riparian willow stands with adjacent habitat types usually increases as the lateral distance from the stream or adjoining relief increases.

554



Above: caption: "Plate 6. Riparian Willow; bordering Fish Creek (A.S. 33), a major tributary to the Gulkana River between Paxon and Summit Lakes in the Alaska Range." 555

Subalpine (07)
Subalpine is often found as a narrow band between some of the previously described habitat types and alpine tundra. Under those circumstances, it was not considered as a separate habitat type in this evaluation. Where subalpine exists as a major and relatively wide transition zone, it was recognized as a distinct habitat type. Subalpine commonly occurs on dry uplands adjacent to or just above treeline.

556

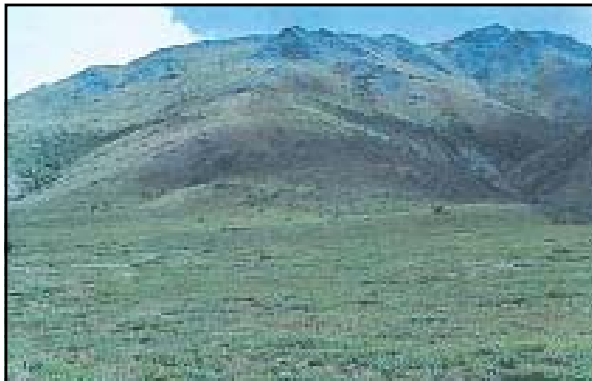

Above: caption: "Plate 7. Subalpine; looking east from the Haul Road (A.S. 108), approximately three miles south of Chandalar Shelf in the Brooks Range." 557

Alpine Tundra (08)
Alpine tundra occurs at higher elevations in mountain ranges and on exposed dry ridges in the arctic. Barren rock is prevalent with vegetation often sparse and normally only a few inches high. Low mat-forming herbaceous and woody plants are dominant with certain species of grasses, dry-land sedges, and lichens present.

558



Above: caption: "Plate 8. Alpine Tundra; north side of Atigun Pass (A.S. 110) in the Brooks Range." 559

Tussock Tundra (09)
Tussock tundra is one of the most widespread habitat types north of the Brooks Range. It is relatively monotypic with cottongrass (Eriophorum vaginatum) the primary species. Mosses and lichens are common.

560



Above: caption: "Plate 9. Tussock Tundra; view west of the Haul Road (A.S. 115) and north of Galbraith Lake. Note evidence of winter trail through center of photo." 561

Wet-Meadow Tundra (10)
Wet-meadow tundra occurs north of the Brooks Range and is prevalent on the Arctic Coastal Plain. It is the largest continuous wetland complex crossed by the TAPS. Major physical features include: areas with little topographic relief, widespread polygonal ground, and numerous ponds, lakes, and intermittent streams. The ground surface is closely underlain by permafrost and standing water is common in the summer.

562



Above: caption: "Plate 10. Wet-Meadow Tundra; southwest of Pump Station 1. Note the deep open lake, water filled polygons, and flooded tundra." 563

Unvegetated Floodplain (11)
This habitat type is found on active floodplains of major riverine systems in which flooding and severe scouring are frequent. For the most part, vegetation is extremely limited or nonexistent. However, grasses and other herbs may seasonally exist in scattered locations. Gravel to boulder-size rocks, sand/silt bars, and floodplain debris are the characteristic components of this habitat type.

564



Above: caption: "Plate 11. Unvegetated Floodplain; view of Lower Miller Creek floodplain upstream from the oil pipeline crossing (A.S. 39) and Richardson Highway in the Alaska Range." 565

Agricultural Land (12)
The Tanana Valley, Fairbanks to Delta Junction, is one of the two large farming areas in Alaska and is the only agricultural district coursed by the TAPS. Major agricultural products of this area are small grains, forages, and root crops. Based on the frequency of use for agricultural purposes, "croplands" undergo various degrees of reinvasion by native plant species. In this evaluation, only that land which has been determined to be free from the incursion of native grasses, shrubs, and trees has been classified as agricultural land.

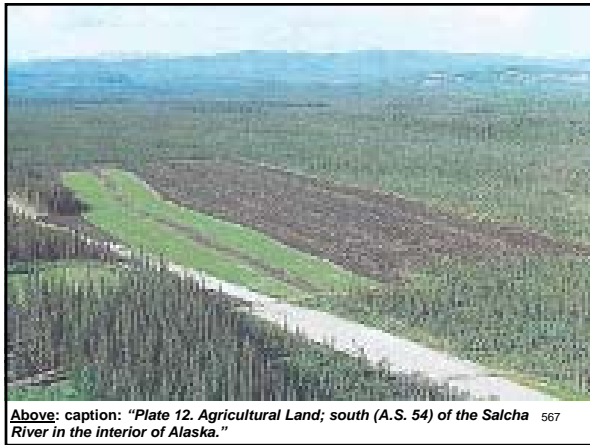

Above: caption: "Plate 12. Agricultural Land; south (A.S. 54) of the Salcha River in the interior of Alaska." 567

Quantitative Phase

Post-construction Imagery
In order to compare pre- and post-construction imagery, panchromatic black and white negatives (scale 1:36000), taken aerially in June and July 1976, were enlarged approximately six times using a commercial enlarger. By using a pre-construction image of the same area as an enlarging guide, post-construction imagery of the same scale was produced. This was done to allow the direct comparison of pre-construction habitat type overlays with enlarged post-construction imagery. Post-construction imagery of the TAPS consisted of 362 panchromatic black and white photographic enlargements with an approximate scale of 1:6000.

Areal Calculation of Construction-Related Impacts
Following identification of construction-related impacts on post construction imagery, the pre-construction habitat type overlays, having the same scale as the post-construction imagery, were aligned with the appropriate post-construction image. In this manner, the pre-construction overlays revealed the habitat types prior to TAPS construction. Having identified the type of construction impact, the limits of that impact, and the habitat types altered, an electronic planimeter/calculator with a variable scale function was used to calculate the areal extent of construction impacts.

Qualitative Phase

571

General

Without a basic understanding of the qualitative values associated with wildlife habitats, knowledge of quantified habitat losses is meaningless. The primary purpose of the qualitative phase was to determine the overall value or quality of each of the twelve habitat types relative to the myriad of wildlife species which these habitats support. To accomplish this task, a systematic and empirical approach was used.

572

Biological Parameters

For each selected wildlife species, a detailed literature review was conducted to compile available data concerning habitat requirements and preferences. The information was categorized by three basic biological parameters (food, cover, and reproduction) and analyzed for each wildlife species. A fourth parameter, migration/movement, was included initially, but was dropped from the evaluation due to insufficient information in the literature relative to habitat types.

573

Findings

574

Habitat Typing

As a result of cover typing the study area on pre-construction aerial photographs, a mosaic of habitat types was produced which is equivalent to approximately 2,150 square miles. This area is equal to approximately 1.37 million acres (an area slightly larger than the State of Delaware).

575

Construction-Related Impacts

As previously noted, summary sheets of TAPS construction-related impacts on terrestrial wildlife habitats are contained in Appendix II. The impacts are recorded by pipeline construction section (Figure 2) and land ownership. It should be re-emphasized that a conservative approach was used in determining TAPS impacts. Also, construction of the TAPS was not complete at the time (July, 1976) the "post-construction" photographs were taken. The author estimates that approximately 95% of the surface disturbances associated with TAPS construction occurred prior to July, 1976. A few of the twelve pump stations (Plates 27 & 28) had not been constructed or were partially constructed (e.g. Pump Stations 2 and 7). Numerous spur dikes (Plates 24 & 29) were not constructed, particularly in Sections 5 and 6. A few material sites (Plates 29 - 34) were expanded after the photography date. The facilities at the Valdez Terminal (Plate 23) were not complete. The Haul Road (Plates 15, 16 & 21) access roads (Plates 21, 32, & 34), work pad (Plates 17-21 & 24) and camps (Plates 25 & 26) had been constructed.

576



Left: caption: "Plate 28. Pump Station 9 which was constructed in spruce-deciduous woodland (HMQ) and spruce woodland (LMQ) in A.S. 44, Section 2. View is east. The work pad joins the north and south sides of the site (about 43 acres). June, 1977."
Bottom: caption: "Plate 24. Spur dike construction (dozer on 'nose' of dike) and river-crossing staging area on the Hammond River, A.S. 101, Section 5. The pipeline crosses the Middle Fork Koyukuk River in the upper right corner of the photo. View is north. Haul Road is to the west of the pipeline. June, 1976." 577



Top: caption: "Plate 29. M.S. 101-1 located in and adjacent to the Middle Fork Koyukuk River in A.S. 101, Section 5. The southern portion of the site has clear ponded water while the northern aliquot (right side of photo at end of access road) is nearly all submerged by flowing water. The work pad intersects armored spur dikes. June 1976."
Bottom: caption: "Plate 30. M.S. 106-2 located in the Dietrich River floodplain, A.S. 106, Section 5. This material site destroyed primarily riparian willow (HMQ). It was mined deep on the south end to provide overwintering habitat for fish. Open trench for below-ground pipe and the Haul Road can be seen on the right side of the photo. June, 1976." 578



Top: caption: "Plate 31. M.S. 112-3.1 and a disposal area built in tussock tundra (MQ) and alpine tundra (LMQ) on the north side of the Brooks Range, A.S. 112, Section 5. View is north. An access road leads to site. Work pad lies between the Atigun River and the Haul Road in photo background. June, 1976."
Bottom: caption: "Plate 32. M.S. 108-2 located primarily in subalpine (MQ) habitat, A.S. 108, Section 5. An access road from the Haul Road was constructed through shrub thicket (HMQ) and spruce woodland (LMQ). View is west. June, 1976." 579



Top: caption: "Plate 33. M.S. 105-1 adjacent to Snowden Creek, A.S. 105, Section 5. This upland site was located in spruce woodland (LMQ). View is north. The work pad forms the eastern border of this material site. June, 1976."
Bottom: caption: "Plate 34. Material site located in the floodplain of the Sagavanirktok River, Section 6. View is west toward the pipeline and Haul Road. Note access road to site. Riparian willow (HMQ) and unvegetated flood-plain (LQ) habitats were most affected by this mining operation. Over 5,200 surface acres were mined in the Sagavanirktok floodplain. 580 July, 1977."

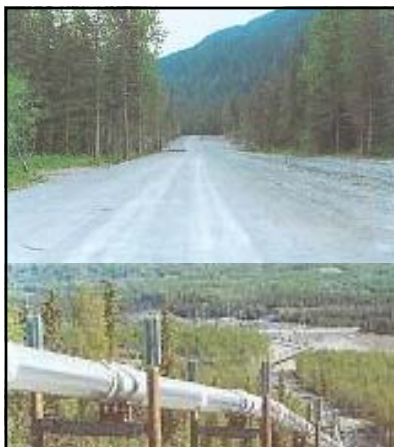

Top: caption: "Plate 17. A section of work pad and completed below-ground pipeline through coastal forest (MQ) in A.S. 2, Section 1. The pipeline is buried on the right side with the driving surface on the left. June 1977."
Bottom: caption: "Plate 18. A section of above-ground (elevated) pipeline constructed in spruce-deciduous woodland (HMQ) in A.S. 21, Section 1. A staging area on the south bank of the Tazlina River can be seen in the center of the photo. Note the thermal radiators used to dissipate heat atop the vertical support members (VSM's). The 48 inch pipe is encased in a galvanized covering and attached to steel, sliding 'shoes' which rest upon cross members. June, 1977." 581



Top: caption: "Plate 19. Work pad and elevated pipeline built through wetlands (HQ) in A.S. 103, Section 5. View is north. Cross-drainage is from east to west; note ponding on right side of pad. June, 1977."
Bottom: caption: "Plate 20. A section of work pad through wet-meadow tundra (HQ) in A.S. 137, Section 6. View is north. The fuel gasoline can be seen on the west side of the pad with the 48" pipeline on the right side. Both segments of pipe are resting on wooden cribs prior to installation. Note ponding on west side of pad throughout photo. June, 1976." 582



Above: caption: "Plate 21. A section of revegetated work pad through spruce woodland (LMQ) near Gold Creek in A. S. 102, Section 5. View is south. The Haul Road parallels the work pad on the east side with an access road connecting the two. June, 1976." 583



Top: caption: "Plate 25. Five-mile Camp built in spruce-deciduous woodland (HMQ) approximately five miles north of the Yukon River in Section 4. Elevated pipeline, the Haul Road, and the camp airstrip can be seen near the top of the photo. June, 1977."



Bottom: caption: "Plate 26. Chandalar Camp built in subalpine (MQ) and riparian willow (HMQ) habitats, A.S. 109, Section 5. View is north toward the Continental Divide in the Brooks Range. Access roads from the Haul Road can be seen coming down to the work pad in the North Fork of the Chandalar River. The camp airstrip is located between the work pad and M.S. 109-3 (right side of photo). June, 1976." 584

Impacts By Land Ownership

Approximately two-thirds of the lands crossed by TAPS were federally owned. Slightly less than one-third were state lands, and the remaining lands were privately owned.

585

Federal Lands

Of all habitat types on federal lands in Section 1, spruce-deciduous woodland (HMQ) received the largest impact. Unvegetated floodplain (LQ) and spruce woodland (LMQ) were the most affected habitat types in Section 2. Spruce-deciduous woodland (HMQ) received over 50% of the total impacts in Section 3. The greatest impacts in Section 4 were to spruce woodland (LMQ) and spruce-deciduous woodland (HMQ). The most significant quantitative habitat loss (905 acres) for riparian willow (HMQ) occurred in Section 5, and 2,276 acres of tussock tundra were destroyed in Section 6. A total of 1,269 acres of wetlands (HQ) and 170 acres of wet-meadow tundra (HQ) were damaged by TAPS construction on federal lands.

586

State Lands

The greatest impacts (combined 63%) of TAPS construction on state lands were to unvegetated floodplain (LQ) and wet-meadow tundra (HQ). There were no state lands in Section 5 and the minor impacts (5 acres) shown for Section 4 reflect that this section was nearly all federal land. Section 6 accounted for over 59% of the total impacts of TAPS on state lands. In Section 1, coastal forest (MQ) was affected more than any other habitat type with 409 acres removed. The impacts in Section 2 were relatively evenly distributed. Spruce-deciduous woodland (HMQ) and spruce woodland (LMQ) bore the greatest losses in Section 3.

587

Private Lands

The most significant impacts of TAPS construction on private lands occurred at the Valdez Terminal where 129 acres of coastal forest (LMQ) and 517 acres of shrub thicket (HMQ) were lost. Although TAPS impacts on freshwater and marine environments were not evaluated in this study, approximately 80 acres of intertidal marine habitats were filled at the Valdez Terminal site. Thus, the total impact of the Valdez Terminal was about 726 acres, as of July, 1976. Shrub thicket (HMQ) received the greatest impacts on private lands. Impacts on spruce-deciduous woodland (HMQ) totaled 408 acres with the majority of these losses occurring in Sections 2 and 3.

588

Summary

A summary of the overall habitat losses by land ownership is shown in Table 4. Agricultural land (LQ) was more adversely affected by TAPS on private lands (28 acres) than on either state or federal lands. Coastal forest (LMQ), wet-meadow tundra (HQ), and unvegetated floodplain (LQ) incurred their greatest losses on state lands. Seventy-eight percent of the impacts on spruce-deciduous woodland occurred on federal lands. Losses of riparian willow (HMQ) and tussock tundra (MQ) on federal lands amounted to 86.7% and 99.5%, respectively, of the total impact on these habitat types. Overall, federal lands had 66.7% of the total TAPS impacts with 28.9% of the impacts on state lands and 4.4% on private lands.

589

Habitat Type	Federal Lands	State Lands	Private Lands	Subtotal
Coastal Forest (HQ)	-0-	409	177	586
Spruce-Deciduous Woodland (HMQ)	4967	958	408	6333
Spruce Woodland (LMQ)	3580	547	82	4209
Wetlands (HQ)	1269	334	29	1632
Shrub Thicket (HMQ)	387	484	592	1463
Riparian Willow (HMQ)	2105	320	-0-	2425
Subalpine (MQ)	1465	251	-0-	1716
Alpine Tundra (LMQ)	293	40	-0-	333
Tussock Tundra (MQ)	2720	14	1	2735
Wet-Meadow Tundra (HQ)	170	1552	-0-	1522
Unvegetated Floodplain (LQ)	3982	4376	58	8416
Agricultural Land (LQ)	3	4	28	33
Subtotal	20939	9089	1375	Total 31403

Above: caption: "Table 4. Summary of Impacts (shown in acres) on Terrestrial Habitats by Land Ownership."

590

Impacts By Construction Section

The approximate linear distance of each TAPS construction section is as follows: Section 1 - 150 miles, Section 2 - 150 miles, Section 3 - 142 miles, Section 4 - 138 miles, Section 5 - 75 miles, and Section 6 - 145 miles. In reviewing TAPS impacts by construction section, it is important to remember the length of the sections relative to the quantitative impacts. It also is beneficial to keep in mind the distribution of habitat types as previously discussed. The largest area of disturbance occurred in Section 6 (Table 5) with the loss of 10,900 acres of terrestrial wildlife habitat. This is equivalent to 34.7% of the total TAPS impact to terrestrial habitats. When comparing the linear extent of the construction sections to the amount of lost habitats, Sections 1 and 3 had the least quantitative impacts. It is important to note that these two sections had the most developed facilities prior to the TAPS. The total number of surface acres damaged for each habitat type relative to the percent of total impact is shown in Table 6. Unvegetated floodplain (LQ) received the greatest overall impacts, followed by spruce-deciduous woodland (HMQ) and spruce woodland (LMQ). Agricultural land (LQ) and alpine tundra were the least affected habitat types.

591

Habitat Type	Construction Section						Subtotal
	1*	2	3	4	5	6	
Coastal Forest (HQ)	129	457	---	---	---	---	586
Spruce-Deciduous Woodland (HMQ)	---	1075	687	1670	1637	464	6333
Spruce Woodland (LMQ)	---	210	1082	718	1783	416	4209
Wetlands (HQ)	---	225	246	334	425	231	1632
Shrub Thicket (HMQ)	517	437	192	110	133	62	1463
Riparian Willow (HMQ)	---	-0-	195	-0-	82	905	2425
Subalpine (MQ)	-0-	-0-	841	15	711	149	1716
Alpine Tundra (LMQ)	-0-	40	-0-	-0-	23	246	333
Tussock Tundra (MQ)	---	---	---	---	206	239	2735
Wet-Meadow Tundra (HQ)	---	---	---	---	---	---	1522
Unvegetated Floodplain (LQ)	---	313	1545	71	76	773	8416
Agricultural Land (LQ)	---	4	3	28	---	---	33
Subtotal	646	3561	4789	2946	5076	3485	Total 31403

Above: caption: "Table 5. Impacts (shown in acres) to Terrestrial Habitats by Section."

592

Habitat Type	Impacts (Acres)	Percent of Total Impact
Coastal Forest (HQ)	586	1.9
Spruce-Deciduous Woodland (HMQ)	6333	20.2
Spruce Woodland (LMQ)	4209	13.4
Wetlands (HQ)	1632	5.2
Shrub Thicket (HMQ)	1463	4.7
Riparian Willow (HMQ)	2425	7.7
Subalpine (MQ)	1716	5.5
Alpine Tundra (LMQ)	333	1.0
Tussock Tundra (MQ)	2735	8.7
Wet-Meadow Tundra (HQ)	1522	4.8
Unvegetated Floodplain (LQ)	8416	26.8
Agricultural Land (LQ)	33	0.1
Total	31403	100.0

Above: caption: "Table 6. Summary of Impacts on Terrestrial Habitat Types."

593

Impacts By Construction Activity

During the course of this evaluation, it became obvious that the pipeline operational facilities necessary for oil transport (e.g. an 800-mile/48 inch pipeline, pump stations, and terminal facilities) caused significantly less damages to terrestrial wildlife habitats than the related activities (e.g. material sites, Haul Road, work pad, and access roads) associated with the construction effort. In order to determine those activities which had the most effects on terrestrial habitats, the impacts associated with pipeline operational facilities and construction-related facilities were analyzed. Impacts, categorized by construction activity for each section, are shown in Table 7. Percent of impacts by construction activity for each section are contained in Table 8 and a summary of construction-related impacts is shown in Table 9.

594

Construction Activity	Construction Section						Subtotal		
	7*	1	2	3	4	5			
Haul Road	-0-	-0-	-0-	-0-	1432	841	1478	3751	
Work Pad	-0-	1899	2160	1774	1731	1097	1949	10610	
Access Roads	-0-	144	111	245	276	76	344	1196	
Camps	-0-	181	124	75	134	83	148	745	
Pump Stations	-0-	80	154	89	41	-0-	111	485	
Material Sites	-0-	746	1575	552	1159	1268	6528	11828	
Disposal Sites	-0-	276	239	97	32	4	49	697	
Spur Dikes	-0-	47	134	-0-	27	23	16	247	
Miscellaneous**		646	188	292	114	244	93	267	1844
Subtotal		646	3561	4789	2946	5076	3485	10900	Total 31403

*Terminal
**Includes airfields, staging areas, guidebanks, unidentified impacted areas, and the Valdez Terminal facilities located on uplands.

The Haul Road (Plates 15, 16, & 17) was constructed in Sections 4, 5, and 6 and resulted in the permanent loss of 3,751 acres (Table 7) of terrestrial habitats.
Above: caption: "Table 7. Construction-Related Impacts (shown in acres) by Section." 595

Construction Activity	Construction Section						Subtotal	
	7*	1	2	3	4	5		
Haul Road	0.0	0.0	0.0	0.0	28.2	24.1	13.6	
Work Pad	0.0	53.3	45.1	60.2	34.1	31.5	17.9	
Access Roads	0.0	4.0	2.3	8.3	5.5	2.2	3.2	
Camps	0.0	5.1	2.6	2.6	2.7	2.4	1.4	
Pump Stations	0.0	2.2	3.2	3.0	0.8	0.0	1.1	
Material Sites	0.0	21.0	32.9	18.7	22.8	36.4	39.9	
Disposal Sites	0.0	7.8	5.0	3.3	0.6	0.1	0.4	
Spur Dikes	0.0	1.3	2.8	0.0	0.5	0.6	0.1	
Miscellaneous**	100.0	5.3	6.1	3.9	4.8	2.7	2.4	
Total	100.0	100.0	100.0	100.0	100.0	100.0	100.0	

*Terminal
**Includes airfields, staging areas, guidebanks, unidentified impacted areas, and the Valdez Terminal facilities located on uplands.

Above: caption: "Table 8. Percent (0.0%) of Construction-Related Impacts by Section." 596

Construction Activity	Impacts (Acres)	Percent of Total Impact
Haul Road (H.R.)	3751	11.9
Work Pad (W.P.)	10610	33.8
Access Roads (A.R.)	1196	3.8
Camps	745	2.4
Pump Stations (P.S.)	485	1.5
Material Sites (M.S.)	11828	37.7
Disposal Sites (D.S.)	697	2.2
Spur Dikes (S.D.)	247	0.8
Miscellaneous* (Misc.)	1844	5.9
Total	31403	100.0

*Includes airfields, staging areas, guidebanks, unidentified impacted areas, and the Valdez Terminal facilities located on uplands.

Above: caption: "Table 9. Summary of Construction-Related Impacts." 597

Habitat Type	Construction Activity												Subtotal
	H.R.	N.F.	A.R.	Camps	P.S.	M.S.	D.S.	S.D.	Misc.				
Coastal Forest (CF)	---	371	10	40	---	71	55	1	129	506			
Spruce-Deciduous Woodland (SD)	481	2896	316	269	231	1653	207	25	255	6339			
Spruce Woodland (SW)	746	2220	211	57	61	491	167	45	211	4209			
Wetlands (W)	237	958	94	36	3	63	58	6	137	1832			
Shrub Thicket (ST)	92	378	42	37	12	251	58	26	566	1463			
Riparian Willow (RW)	208	745	84	41	16	1154	24	24	129	3425			
Subalpine (S)	215	894	92	68	36	318	77	26	30	1726			
Alpine Tundra (AT)	146	116	4	3	-0-	48	5	4	7	333			
Tussock Tundra (TT)	1047	826	135	79	62	523	16	1	46	2735			
Wet-Meadow Tundra (WT)	507	778	87	49	55	4	17	1	24	1522			
Revegetated Floodplain (RF)	52	559	112	66	9	7227	13	88	290	8416			
Agricultural Land (AL)	---	8	-0-	-0-	-0-	25	-0-	-0-	-0-	33			
Subtotal	3751	10610	1196	745	485	11828	697	247	1844	31403			

The overall impacts of each construction activity in relation to the twelve habitat types are shown in Table 10. The names of the construction activities follow the abbreviations defined in Table 9.
Above: caption: "Table 10. Impacts (shown in acres) of Construction Activities on Habitat Types." 598

An analysis was conducted of the habitat evaluation findings and the land requirement estimates contained in the final environmental impact statement (FEIS) for the TAPS. The FEIS estimated that 61.3 square miles or about 39,232 surface acres would be directly involved in the construction of TAPS (U.S. Dept. Int. 1972). About 43.4 square miles (27,776 acres) were considered to be permanent or long-term impacts. The remaining 17.9 square miles (11,450 acres) were categorized as temporary impacts. The FEIS estimated that approximately 67.5 million cubic yards of gravel would be needed to construct the TAPS including the Haul Road. Each pump station would require approximately 50 surface acres and the Valdez Terminal would destroy about 910 acres. Gravel and quarry sites were estimated to total 5,760 acres. By extrapolating the quantitative data in Table 9, comparisons were made between the FEIS estimates and JFWAT's findings concerning surface impacts by the various construction activities (Table 11). An extrapolation of JFWAT's findings was necessary because the findings do not reflect the total "as-built" impacts due to incomplete post-construction imagery, or certain construction impacts were not finished as of July, 1976 (date of post-construction imagery). The "difference" column represents the numerical difference in acres between the FEIS estimates and JFWAT's findings.

599

Construction Activity	FEIS Estimates	JFWAT Findings*	Difference
Haul Road	3750**	-4000***	-4750
Work Pad	14065	10800	-3265
Access Roads	2770	1230	-1540
Camps	1190	800	-390
Pump Stations	701	610	-93
Material Sites	5760	12200	+6440
Disposal Sites	---	735	+735
Spur Dikes	---	400	+400
Valdez Terminal	910	825	-85
Miscellaneous	1827****	1900	-737
Total	39215	33500*	-5715

*Indicates extrapolation of data from Table 9.
**Based on the 200 foot right-of-way permanently dedicated for the Haul Road; does not reflect estimates of direct surface impacts.
***Direct surface impacts within the 200 foot right-of-way. Average width of Haul Road disturbance is about 88 feet.
****Includes temporary and permanent airfields, communication sites, and material storage sites.

Various wildlife species have been observed feeding in revegetated areas (Plate 22).
Above: caption: "Table 11. Comparison of FEIS Estimated TAPS Impacts to JFWAT Findings (impacts in acres)." 600

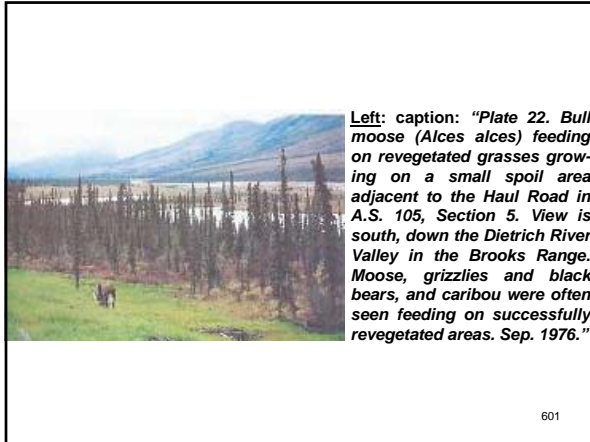

Left: caption: "Plate 22. Bull moose (*Alces alces*) feeding on revegetated grasses growing on a small spoil area adjacent to the Haul Road in A.S. 105, Section 5. View is south, down the Dietrich River Valley in the Brooks Range. Moose, grizzlies and black bears, and caribou were often seen feeding on successfully revegetated areas. Sep. 1976."

601

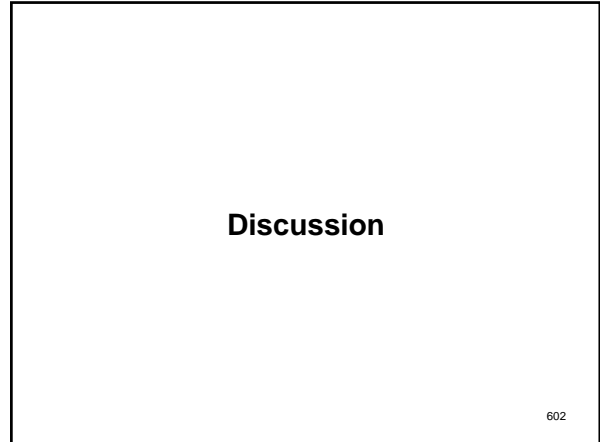

Discussion

602

JFWAT's terrestrial habitat evaluation dealt strictly with the physical impacts of TAPS construction on terrestrial wildlife habitats. This included those areas destroyed by permanent facilities as well as temporary use areas where surface disturbances occurred. No attempt was made to evaluate effects of pipeline construction on wildlife populations or behavior. Some examples of adverse effects of TAPS construction not covered in this evaluation include:

- (1) noise,
- (2) dust,
- (3) harassment of wildlife (especially grizzly bears, Dall sheep, moose, and caribou) by aircraft and vehicles,
- (4) blasting,
- (5) animal feeding (particularly bears, wolves, and foxes),
- (6) attraction of wildlife to camp refuse areas,
- (7) interruptions in normal migration and movement patterns,
- (8) illegal hunting, and
- (9) other human disturbances.

The impacts on wildlife habitats resulting from construction-related fuel spills, crude oil spills (Plate 13), man-caused thermal erosion (Plate 14), snow pads, and winter trails were not evaluated.

603

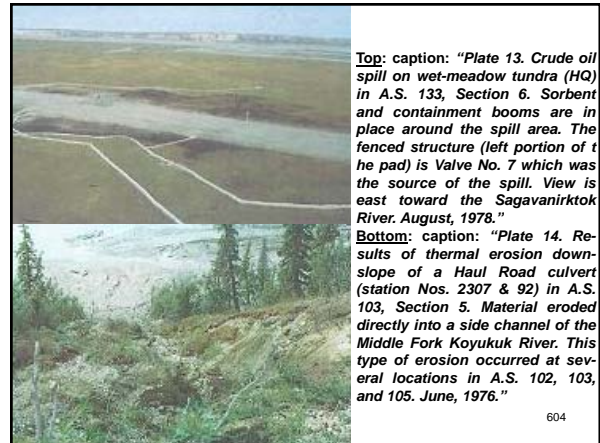

Top: caption: "Plate 13. Crude oil spill on wet-meadow tundra (HQ) in A.S. 133, Section 6. Sorbent and containment booms are in place around the spill area. The fenced structure (left portion of the pad) is Valve No. 7 which was the source of the spill. View is east toward the Sagavanirktok River. August, 1978."

Bottom: caption: "Plate 14. Results of thermal erosion down-slope of a Haul Road culvert (station Nos. 2307 & 92) in A.S. 103, Section 5. Material eroded directly into a side channel of the Middle Fork Koyukuk River. This type of erosion occurred at several locations in A.S. 102, 103, and 105. June, 1976."

604

Construction camps ranged in size from about 25 acres to 50 acres. Camp airstrips and associated facilities varied in size from about 10 to 75 acres. Pump stations required between 38 and 55 acres per site. The Haul Road was built in the northern sections for three main purposes:

- (1) provide ground access for the logistical support of TAPS construction north of the Yukon River,
- (2) provide easy access to the oil pipeline and related facilities during the operation and maintenance phase of the TAPS, and
- (3) provide an overland transportation corridor to the Prudhoe Bay oil and gas fields and for future developments.

As previously shown, construction of the Haul Road caused some of the most significant adverse impacts to high, high-medium, and medium quality wildlife habitats (Table 10). Continuing secondary impacts to wildlife habitats associated with the Haul Road include drainage alterations, auffs, erosion, and fuel spills.

605

Future construction projects which require large amounts of gravel can be expected to cause significant widespread damages to terrestrial wildlife habitats which are part of major river floodplains, particularly in arctic regions. Secondary impacts resulting from hydrologic changes also can be anticipated. These statements are based on the following:

- (1) either the gravel sources are located primarily in floodplain areas, or
- (2) the gravel sources are easily obtainable in the floodplain areas and approving officials concur with their exploitation in lieu of alternative sources.

Borrow materials (i.e. gravel, shotrock, etc.) from nearly 300 material sites were used to construct the Haul Road, work pad, access roads, spur dikes, camp pads, and other features of the TAPS. Burger and Swenson (1977) reported that approximately 61 million cubic yards of material had been extracted for TAPS construction purposes as of February, 1976. This information, coupled with the knowledge that approximately 11,828 acres of terrestrial habitat were altered to obtain this quantity of material, clearly indicates that siting of material sites is critical in minimizing unnecessary adverse impacts to wildlife habitats. This is especially important when material sites are used during construction and throughout the operation phase of a project. Numerous TAPS material sites will be used during the operational phase for maintenance activities (e.g. Haul Road, work pad, and spur dikes).

606

Proposed access routes were evaluated first for actual need and proximity to adjacent access roads. Following justification of a particular access road, its proposed alignment was scrutinized with respect to potential adverse environmental impacts and possible difficulties from a construction standpoint. In several instances, proposed access roads were moved to alternate locations or shifts made in the original alignments to avoid unnecessary loss of higher quality wildlife habitats.

607

Factors which play significant roles in the selection of material site locations are the availability of borrow materials that meet construction specifications, economics, potential difficulties associated with mining the materials, and environmental consequences. If severe impacts to wildlife habitats are to be minimized in future projects, it is imperative that proposed material site locations be evaluated by a process similar to that discussed above for roads and other project-related facilities.

608

Both industry and government used the inter-disciplinary approach during the planning phase of the TAPS. This approach also was used to varying degrees during TAPS construction. There was, however, little biological input into the alignment planning and construction of the Haul Road. TAPS impacts on wildlife habitats were quantitatively less than the FEIS predictions because of two basic reasons:

- (1) government design review and field monitoring of TAPS construction on an inter-agency/inter-disciplinary basis, and;*
- (2) a generally comprehensive and enforceable set of stipulations designed to ensure pipeline integrity and protect environmental values.*

609

Adverse impacts on wildlife habitats undoubtedly would have been greater had there not been government surveillance and enforcement of environmental and technical stipulations for construction and operation of the TAPS. There were many instances, during the construction of TAPS, where construction philosophies did not coincide with the best means for ensuring environmental protection. For example, most contractors wanted a normal work pad width for convenience at a small stream crossing rather than a "necked down" pad which would have decreased the destruction of riparian vegetation and minimize instream disturbances. Many contractors would have preferred to place overburden spoil from a newly opened floodplain material site into an adjacent wetland, stream channel, or floodplain rather than take the spoils to a mined-out, upland material site for disposal. The fact that sufficient erosion controls were not implemented, in many instances, until the summer of 1977 clearly indicates that environmental protection was oftentimes precluded by construction schedules.

610

The TAPS is an unprecedented "working model" of the environmental successes and failures of a major construction project in subarctic and arctic environments. Knowledge gained from TAPS is applicable to virtually all types of future construction projects. As time progresses, the long-term impacts and cumulative ramifications of TAPS on wildlife resources will become more apparent. Government and industry both have the responsibility and opportunity to work together to ensure that the expanding TAPS information base is used to benefit public wildlife resources which are threatened by the TAPS' operation phase, as well as future developments in the State of Alaska.

611

Recommendations

612

JFWAT's terrestrial habitat evaluation resulted in numerous recommendations, some are applicable to the TAPS' operational phase and others to future development projects in Alaska. Recommendations are separated into four categories.

613

1. General recommendations - possibly the most crucial for protecting wildlife resources threatened by major projects:

- (a) During all phases of project development, an inter-agency/inter-disciplinary approach must be used to evaluate the potential adverse impacts of all project features on wildlife habitats. Examples of projects are: new facilities in the Prudhoe Bay oil and gas fields, oil development in the Kuparuk region, Susitna Hydroelectric Project, and the proposed Alaskan gas pipeline.
- (b) Government agencies must ensure that comprehensive terrestrial (and aquatic) habitat evaluations of proposed project areas are conducted to identify wildlife (and fish) habitats in terms of quantity and quality.
- (c) Emphasis must be placed on these evaluations during the preliminary planning and design stages prior to the construction phase.
- (d) Results of inter-disciplinary evaluations must be incorporated into project designs to ensure the protection of wildlife habitats.
- (e) Regardless of the habitat type, unnecessary and avoidable impacts must be eliminated.
- (f) When adverse impacts are unavoidable, the least environmentally damaging alternative must be selected.
- (g) Mitigative measures must be applied consistently throughout project development (e.g. alignment shifts, minimum pad widths, use of environmentally acceptable existing facilities, adequate cross drainage, proper waste disposal, and rehabilitation/restoration of disturbed areas).
- (h) The project sponsor(s) should be required to adequately compensate for all significant unmitigated losses of public wildlife resources as determined by government resource agencies.

614

2. Recommendations for the TAPS' operational phase:

- (a) Periodic government surveillance of TAPS and stipulation enforcement must continue to ensure the protection of project-affected wildlife resources.
- (b) APSC's oil spill contingency plans, equipment, and procedures must be periodically reviewed and updated.
- (c) APSC should continue to implement rehabilitation and restoration measures until natural vegetation communities have clearly reestablished on previously disturbed areas. Special attention should be given to restoring riparian willow (HMW) and shrub thickets (HMQ), especially in Sections 5 and 6.
- (d) Government resource agencies, in cooperation with APSC, should continue studies of the TAPS' revegetation program to determine what measures and procedures were successful for different site conditions. A detailed analysis of habitat regeneration should be conducted every fifth year (at a minimum) during the operation phase. This will assist in determining whether or not adequate rehabilitation is taking place.
- (e) Resource agencies must work with the Alaska Department of Transportation (ADOT) and APSC to identify locations along the Haul Road and work pad where drainage alterations, caused by gravel pads, are affecting adversely terrestrial wildlife habitats (e.g. thermal erosion, aufeis, ponding, and downslope dewatering of wetland communities). It is the responsibility of the land managing agencies to ensure that corrective actions for minimizing further damages are implemented in a timely manner.

615

(f) Resource agencies must conduct site-specific evaluations of the effects of gravel pads on wetlands (HQ), wet-meadow tundra (HQ), and associated biota. This is particularly important in areas of the Arctic Coastal Plain where oil and gas developments have increased significantly in the last five years.

- (g) Abandoned access roads, camp pads, and airstrips should be used, whenever technically feasible, as material sources for maintenance operations in lieu of expanding or initiating new operational material sites.
- (h) Once operational material sites are depleted, they must be rehabilitated immediately. Revegetation measures must be applied by the end of the next growing season following the last use of the sites.
- (i) If habitats damaged by TAPS construction and operation do not reestablish or major spills of crude oil severely affect wildlife habitats, compensation measures must be required of APSC to offset serious losses of wildlife resources.

616

3. Recommendations for future oil and gas pipelines:

- (a) See 1 (a-h) above.
- (b) Existing facilities, unless they have been found to be environmentally unsound, should be used to the greatest extent possible in lieu of damaging additional wildlife habitats. These decisions must be based on an inter-disciplinary review of potential adverse effects of existing and proposed facilities.
- (c) The potential for cumulative adverse impacts (e.g. effects of two parallel pipelines on caribou migrations, multiple drainage alterations, etc.) must be analyzed and appropriate actions taken to ensure that these impacts are minimized.
- (d) The use of snow pads for construction of pipelines and resulting impacts on terrestrial wildlife habitats should be further researched.
- (e) An inter-agency/inter-disciplinary surveillance organization must be implemented to review project designs, monitor project construction, and enforce environmental and technical stipulations so that impacts to wildlife habitats can be minimized throughout the project.

617

4. Recommendations for future, non-pipeline, development projects including roads, water-related projects, and mining:

- (a) See 1 (a-h) above.
- (b) Conduct terrestrial and aquatic habitat evaluations in preliminary planning stages for all sites being considered, including alternatives.
- (c) Analyze proposed road alignments, material sites, and other development activities during planning, construction, and operation phases to identify temporary and permanent commitments of terrestrial wildlife habitats.
- (d) Ensure that mitigative measures for unavoidable adverse impacts are incorporated into project designs and implemented during the construction, operation, and termination phases. Major development activities must be periodically monitored during operation so that unforeseen environmental impacts (e.g. drainage alterations and subsequent adverse effects on vegetation) can be corrected in a timely manner without unnecessary habitat losses for the project duration.
- (e) Temporary-use facilities (e.g. construction camps, airfields, equipment storage areas) must be placed in environmentally sound locations which can be easily rehabilitated at completion of use. Recognize that temporary use of a habitat does not necessarily mean temporary disturbance. Some habitats are difficult, if not impossible, to restore (e.g. alpine tundra) and conventional measures may not be effective.
- (f) Restoration and revegetation measures must be applied to disturbed areas as soon as construction or use of those areas is completed.
- (g) Prior to construction, project sponsors should be required to post bonds which include assessments for potential damages to public wildlife resources. Funds for re-establishing wildlife habitats (both quantity and quality) also should be included.

618

Summary

619

A classification system composed of twelve habitat types was used to cover type the 2,150 square mile study area. Habitat quality was determined by evaluating the food, cover, and reproduction requirements of 24 representative wildlife families with respect to each habitat type. An LSD multiple range test was used to rank order the habitat types into five qualitative groups ranging from high to low quality habitats.

620

Construction of the 800-mile TAPS resulted in the loss of approximately 31,403 acres of terrestrial wildlife habitat. Impacts by land ownership were: 66.7% (20,939 acres) on federal lands, 28.9% (9,089 acres) on state lands, 4.4% (1,375 acres) on private lands. These overall percentages are not surprising since federal lands were involved for about two-thirds of the TAPS with slightly less than one-third of the distance being state lands.

621

Evaluation of the six construction sections indicated that the greatest quantitative impacts occurred in Section 6 with 10,900 acres of terrestrial habitats adversely affected by pipeline construction. This is about 34.7% of the total TAPS impact. Sections 1 and 3 had the least quantitative impacts (3,561 and 2,946 acres, respectively) which were expected since the southern sections had some developed facilities prior to TAPS construction.

622

Coastal forest was damaged (and occurs) only in Section 1 and at the Valdez Terminal. Spruce-deciduous woodland and spruce woodland were lost in all sections, except Section 6 where forest habitats do not exist. Alteration of wetlands, shrub thicket, riparian willow, and unvegetated floodplains occurred in all construction sections. Subalpine habitats were adversely affected in Sections 2 through 5 and alpine tundra was removed in Sections 1, and 4 through 6. Tussock tundra was lost in Sections 4 through 6 and wet-meadow tundra was removed in Section 6. Impacts to agricultural land occurred in the three southern sections.

623

The two habitat types receiving the greatest overall impacts were unvegetated floodplain and spruce-deciduous woodland. The least affected type was agricultural land. The work pad, Haul Road, and access roads contributed the greatest impacts to high quality wildlife habitats. These impacts were both direct (destruction by gravel pads) and secondary (e.g. ponding and dewatering downslope). Material sites damaged more terrestrial wildlife habitats (11,828 acres) than any other construction activity. The work pad caused the second greatest habitat loss (10,610 acres) with the Haul Road third in impacts (3,751 acres).

624

An extrapolation of JFWAT's quantitative findings to encompass all construction impacts resulted in an estimated 33,500 acres of terrestrial habitat damaged by the TAPS. This is 935 acres less than the FEIS prediction (not including the entire 200 foot Haul Road right-of-way) concerning the land requirements of TAPS. Government monitoring and enforcement by inter-agency/inter-disciplinary organizations and a comprehensive set of stipulations are probable reasons the quantitative impacts of TAPS were less than the FEIS predictions.

625

Recommendations for lessening impacts on terrestrial wildlife habitats are made that address the operational phase of TAPS and provide guidance for future development projects. Detailed inter-disciplinary reviews should be made of all proposed project features directly affecting land surfaces (e.g. roads, pipelines, other transportation alignments, material sites, construction camps, and other related facilities). During the early planning stages of a major project, habitat evaluations of alternative sites should be conducted to obtain an overall understanding of the quantity and quality of threatened wildlife resources. The least environmentally damaging alternative should be selected and appropriate mitigation and compensation measures incorporated into project designs.

626

Appendix I: Glossary

627

Above-ground pipeline: segments of the 48 inch oil pipeline constructed above the surface of the ground on vertical support members; also called elevated pipeline.

Access road: secondary roads constructed from main highways and the Haul Road to the TAPS' right-of-way and associated facilities (e.g. the work pad, camps, airstrips, pump stations, material sites, and disposal sites).

Alignment sheet (A.S.): APSC divided the TAPS' corridor into segments or alignment sheets which were used as "blueprints" for site-specific locations and construction information. There were 138 consecutively numbered alignment sheets starting with A.S. 1 at the Valdez Terminal and ending with A.S. 138 at Pump Station 1 near Prudhoe Bay. There were two supplemental sheets (25A and 53A). Each alignment sheet covered an area about 5.75 miles long.

Barge ramps: areas cleared on the banks of the Yukon River to provide docking and working space for operation of a ferry system. This system was used for TAPS' logistical support prior to the completion of the Yukon River Bridge.

628

Below-ground pipeline: segments of the 48 inch pipeline buried below the ground surface. Below-ground pipeline was constructed normally in thaw stable soils. **Camps:** facilities used during TAPS construction for housing personnel, equipment storage and maintenance, and administrative activities.

Camps: facilities used during TAPS construction for housing personnel, equipment storage and maintenance, and administrative activities.

Disposal sites: areas used for disposal of waste materials (i.e. overburden from material sites, ditch spoils, solid waste, etc.) during TAPS construction.

Exploratory test pits: small, localized areas which were excavated to verify the presence or extent of gravel materials.

Explosives storage facilities: sites used for the safe storage of explosive materials. **Material sites:** areas from which various materials (e.g. gravels, riprap) were extracted for use in constructing the TAPS and Haul Road.

Pipe storage yards: cleared areas (usually portions of abandoned material sites) utilized for storage of 48 inch pipe in 40 and 80 foot sections, miscellaneous construction materials, and equipment.

Pump station: a facility constructed for housing mechanical pumps and related machinery used in pumping crude oil through the 48 inch pipeline. There are twelve pump stations in the TAPS.

629

Right-of-way clearing: areas cleared of vegetation in preparation for construction activities; some cleared areas were not used due to incorrect alignment surveying or realignments.

Siltation control facilities: water-control structures (i.e. settling basins) built to reduce downstream siltation resulting from various construction activities.

Spur dikes: a river-training structure, built of gravel materials and armored with riprap, used for floodplain protection of the pipeline during severe flooding and scouring conditions.

Thermal erosion: erosion principally caused by a temperature increase in the thermal regime and subsequent thawing in permafrost areas. Removal of the insulating vegetation mat is a common catalyst.

Staging areas: sites adjacent to rivers where additional clearing was conducted (wider than the normal work pad) to provide more working room for equipment, construction materials, and spoils during river-crossing pipeline construction.

Unidentified impacts: areas unquestionably impacted by TAPS construction, but lacking information as to the exact cause.

Valdez Terminal: TAPS facilities located on Valdez Arm which receive crude oil from the trans-Alaska oil pipeline, provide temporary oil storage, and transfer oil to delivery tanker vessels.

630

Work pad: the pad from which the above and below-ground sections of the pipeline were installed. In most instances, gravel materials were used to construct the work pad. Snow pads and leveled unvegetated floodplains were used also.

Work pad erosion: sites where work pad materials (i.e. gravels and silts) have been transported by water to areas outside of the normal work pad limits.

631

Part 10

Trial & Error

632

The Thin Threaded Line

633

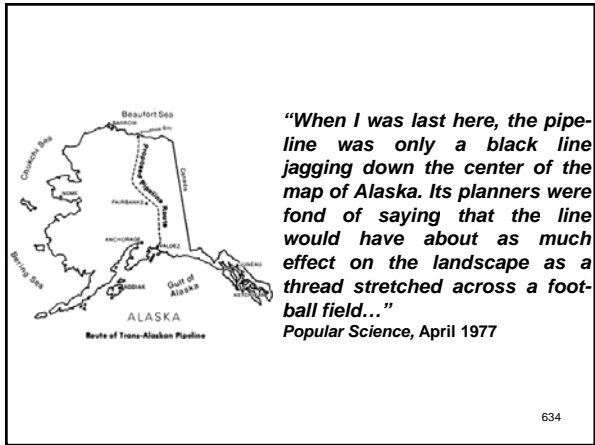

Three Questions

635

"...But many environmentalists, and eventually the U.S. Congress, disagreed. Their concerns boiled down to three questions:

- 1) How would the project affect the tundra?*
- 2) What would it do to wildlife?*
- 3) What would happen if there were a break?..."*

Popular Science, April 1977

636

Then and Now

637

"...Answers were elusive then, but they're becoming clear now that the line is nearly finished (as of January, the project was 92 percent complete and expected to be operating by mid-year). The answers are important; the lessons they provide will be applied to future pipelines and other Arctic projects..."
Popular Science, April 1977

638

What's the Big Deal?

639

"...Everybody knows the basic facts about the 800-mile-long pipeline, built to transport oil from immense reserves at the edge of the Arctic Ocean to ships on Alaska's southern coast. The project is history's biggest undertaking by private enterprise. It might also be the world's most significant environmental experiment. Yet the first impression when you see the pipe is - 'Big Deal.' It's a fat sewer pipe yet to be buried. But then you hear the figures, and you begin to grasp the magnitude of the project:

- The pipeline will carry 1.2 million barrels of crude a day;*
- The project is about 10 times as costly as any private construction job in technological history. Inflation, engineering problems, pressure from environmentalists, and mismanagement have shoved the tab from an estimated \$900 million to a total of about \$8 billion;*
- The line dives under and leaps across rivers and streams nearly 900 times, jockeys over three major mountain ranges and innumerable gorges, and is subjected to temperatures that can drop to minus 70-degrees F..."*

Popular Science, April 1977

640

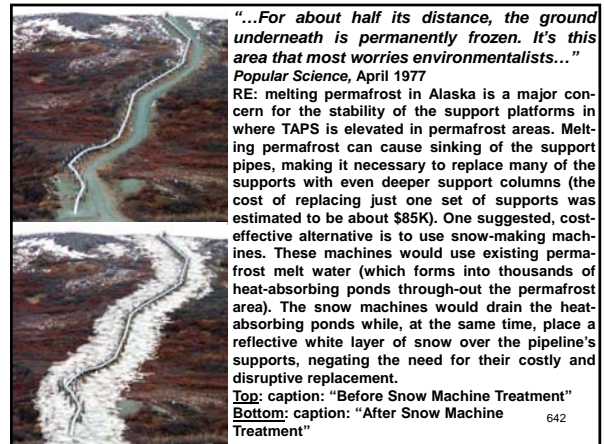

Concern No. 1

643

"...Fly over the frozen North Slope, where the earth tips gently towards the Arctic Ocean. Below is a desert; precipitation is only seven inches a year. And except for a thin surface layer, it's permafrost, made up of frozen rock or muddy ice, reaching down in places to thousands of feet. On the surface lies the tundra - an insulating tangle of mosses, grasses, tiny bushes, five-inch willow trees - life that has struggle years to get a toehold. When the tundra is disturbed, the balance shifts. A truck crossing apparently solid soil in summer can indent the earth a few inches each year, until erosion sweeps away the soil. Today, tracks from World War II trucks are permanent gorges..."

Popular Science, April 1977

644



645



Above: caption: "On the Alaskan tundra, the passage of even one Off-Road Vehicle (ORV) can turn sensitive wetlands into ugly mud bogs, and as subsequent motorists skirt the mess, muddy scars widen to the size of football fields"

646



647

Not So Bad (?)

648



“...That kind of thing is not happening at Prudhoe Bay Oil Field, population 5,000, two hundred miles above the Arctic Circle. A gigantic complex is being built there - yet the oil field, flat as Kansas, looks like a treeless park - clean, neat, tidy...”

Popular Science, April 1977

Above: caption: “Sprawling Prudhoe Bay oil fields.” Six thousand people work in the oil field zone. Most work two week shifts, twelve hours per day, after which they are flown back to their hometowns for two weeks off. They live in APSC “Mancamps,” where all meals are provided free-of-charge. 649

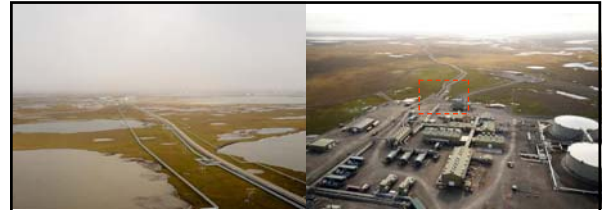

Left: caption: “The North Slope oil fields are spread out across a forty-mile-wide zone along the coast of the Arctic Ocean, between the largely untapped National Petroleum Reserve, to the west, and the Arctic National Wildlife Refuge, to the east. The hundreds of production wells and processing facilities on the slope are connected to one another by elevated pipelines. Wastewater and gas are injected into the ground, pumped away, or burned. The oil is processed at oil company facilities all over the Slope.”

Right: caption: “The purified petroleum converges on Pump Station 1, the beginning of the Trans-Alaska Pipeline, seen here emerging from underground on the edge of the pump station, and heading south. The Alaskan pipeline is the only way for the oil from the fields of the North Slope to get out, to market. The pipeline is what makes these fields viable. The oil flows at around four miles per hour, taking about a week to travel from Pump 1 to Valdez.” 650



Top: caption: “A segment of the 800-mile Trans-Alaska pipeline at a pump station north of Fairbanks”

Bottom: caption: “The Trans-Alaska Pipeline is a four-foot-wide, 800.32-mile-long pipe.” To move the oil, eleven pump stations (four pumps per station) were built along the route. Each is a self-contained small industrial town. Due to a decrease in the volume of oil shipped, and changes in efficiency on the pumps, only seven of the pump stations are currently pumping (the others are on standby). Oil flow peaked in 1988, when 744,107,855 barrels of oil moved through the pipe (at a rate that exceeded two million barrels per day). Now, with reduced production, around 710,000 barrels per day flow through the pipe, about 17% of U.S. crude oil production (ca. 2013) 651



The Trans-Alaska Pipeline showing the pump station (PS) sites



Left: caption: “The pipeline emerges from the ground for the last time and enters the East Manifold Metering Building at the Valdez Marine Terminal. From the metering building it goes either into storage tanks, or directly into tankers, parked at one of four berths. Nearly 20,000 thousand tankers have come and gone from Valdez since the pipeline opened in 1977, carrying more than 15 billion barrels of oil to refineries near Seattle, San Francisco, and Los Angeles.”

Right: caption: “The inlet of the Port of Valdez opens into Prince William Sound, and departing tankers entering the Sound keep a straight course southwest for twenty miles, then turn southeast once they get beyond Bligh Island and its adjacent reef (a tower was constructed to make the top of the reef more visible after the Exxon Valdez accident).” 652



Valdez Marine Terminal, Alaska

653

“...Worries about the tundra have eased in the last year or two. Five years ago, U.S. writers (myself among them) were forecasting that road building would cause disastrous erosion and stream siltation. Now, except for limited tundra flooding (which officials insist is short-term), things don't seem so bad...”

Popular Science, April 1977

RE: six decades of oil field development on Alaska's North Slope, combined with global climate change, have altered the face of the land in ways that were not expected when drilling at North America's largest oil field began in the late 1960s, according to a February 2014 study published online in the journal *Global Change Biology*

654



“The changes are very obvious when you have the before and after pictures”
 Martha Reynolds, Research Biologist at the University of Alaska Fairbanks’ *Institute of Arctic Biology*
 RE: detailed aerial photographs provided much of the basis for the UAF-led 2014 study, which also incorporated permafrost data, weather data and other information. According to Reynolds (the lead author of the study), changes would likely be missed by a casual observer looking at the tundra today, which might appear unaffected by the passage of time. However, the facts-on-the-ground tell another story. Among the changes:

- More small ponds and more areas of standing water on the tundra in summer;
- Accelerated erosion of lake shores, and;
- Hundreds of miles of roads and acres of pads and oil-field buildings that didn’t exist prior to the oil boom.

Although it considered the entire *Central North Slope* and its transformation since 1949, the 2014 study focused on three 20-square-kilometer sections of the sprawling *Prudhoe Bay Oil Field*, areas that have extensive photographic records showing the transformation from the early days of development to the present.

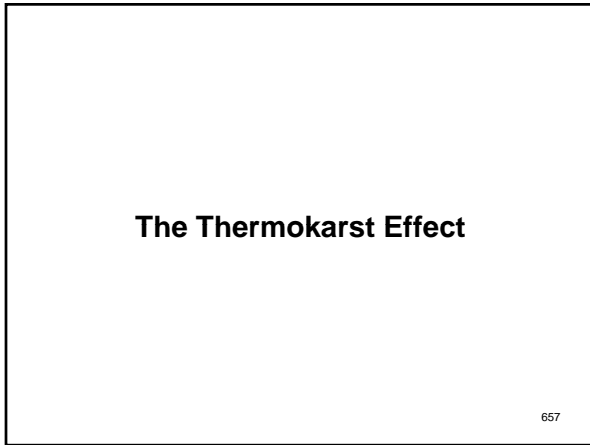

According to the 2014 study, in those areas, 34% of the territory has been physically changed (as of 2010) by oil-field infrastructure that sprouted up since the start of development. That includes land directly covered by roads, well pads, airstrips, pipelines, processing facilities and other man-made structures necessary for producing oil. It also includes the areas nearby that are affected by oil facilities (i.e. sites along roads where water puddles or floods and where vehicle-kicked dust settles). Away from TAPS infrastructure, in the natural landscape, there have also been some significant changes, according to UAF scientists. Of that land, 19% exhibited what the UAF scientists call “expansion of thermokarst features” (between 1990 and 2001, a time of unprecedented warming). These *thermokarst features* emerge when permafrost ice thaws, causing land to settle, sink or otherwise change and sometimes fill with water. The thermokarst effects - most dramatic in the past two decades, have brought about accelerated erosion and changes in vegetation, as well as dimpling and relief changes to a previously flatter landscape, resulting in far-reaching effects, the study stated. Another conclusion of the study was that ice-rich permafrost, such as that at *Prudhoe Bay*, is more vulnerable to change, while drier permafrost is more resilient.



Above: caption: “Teshekpuk Lake on the North Slope of Alaska. Continued warming in Alaska’s Arctic, along with oil development on the North Slope, has dramatically changed the region’s landscape.”
Left: caption: “Melting permafrost from above”

“Based on the mapped information and current air and permafrost temperature trends, starting in 1990 we are witnessing landscape changes that will have major implications for much of the Arctic Coastal Plain”
 Global Change Biology - UAF Institute of Arctic Biology (Joint Study)
 RE: in 2003, scientists from the *National Research Council (NRC)* concluded that even though the Arctic climate was likely to continue warming, with impacts to Arctic sea ice and ecosystems, the North Slope’s permafrost was cold and strong enough to withstand expected increases in ambient air temperature. The later UAF-led study found otherwise. Warming air temperature and the influences of oil-field infrastructure have been strong enough forces to speed thawing and change surface characteristics, according to the study. The NRC study cited permanent roads as among the most significant oil-infrastructure features impacting the *North Slope* environment due to the way they disturb the natural hydrology of the tundra. The NRC study also cited road dust created by summer vehicle traffic as a chronic environmental problem. The UAF-led study made similar conclusions (light road dust can sprinkle nutrients onto nearby ground, encouraging some types of plants to grow and changing the overall vegetation mix, negatively impacting lichen and mosses).

The Haul Road

661



Shortly after the construction work permit was signed (1974), convoys of equipment on snow tractors began heading north, using hardened snow roads and an ice bridge over the *Yukon River* to reach the seven construction camps that had been dormant since 1970. In the 83 days from mid-January to the time the snow and ice melted (in mid-April), 680 workers moved 34K short-tons to the seven existing camps, built five more camps and five temporary airstrips.
Above: caption: "Before construction of the Dalton Highway, special vehicles like the Sno-Freighter were needed to take supplies north of the Yukon River" 662



663

The Yukon Crossing

664

"...If the pipeline and its corridor constitute the line that splits Alaska into east and west, then the Yukon River is the line that splits the state at right angles to the pipeline. The Yukon is a 2,000-mile-long behemoth that flows for 600 miles in the Yukon before crossing the border into Alaska where it flows for another 1,400. It drains 330,000 square miles, and its basin takes up a third of the state. North of the river the state is almost completely roadless, except for the Dalton Highway, which crosses the Yukon at the E.L. Patton Bridge at Yukon Crossing..."
Orion Magazine

665



In February 1975, as the ice bridge and snow road were carrying tracked vehicles north, *Alyeska* awarded a contract to design the construction and maintenance road. *Michael Baker, Jr., Inc.*, a Pennsylvania firm, was awarded the contract. To cross the *Yukon River*, the *Alaska Department of Transportation* designed a bridge and paid two-thirds of its cost and the remaining third was paid by APSC (the bridge was built by *Manson-Osberg-Ghemm*). On April 5th 1975, the contracts to build the road were awarded.
Above: caption: "The Yukon River Bridge, officially known as the E.L. Patton Bridge, is a girder bridge spanning the Yukon River" 666



"...The bridge is half a mile long, a steel structure with wooden planking, and it slopes downward several degrees, which causes no end of consternation for truck drivers when it ices up. The pipeline is carried along-side it in a wire cage. We stopped in the middle. It was as clear an intersection of nature and culture as can be imagined. No subsidiary roads exist on the sides, nor do any other structures bridge the river; there's just the two mighty lines, one natural and one built, intersecting at right angles..."

Orion Magazine

Left: caption: "In this image provided by Alyeska Pipeline Service Company, sections of 48-inch diameter pipe are lowered onto a pipeway along the side of a bridge across the Yukon River in August 1976"

Right: caption: "The Yukon River bridge, looking north, carries both Dalton Highway traffic and the trans-Alaska oil pipeline." 667

An Arctic Mason-Dixon Line

668

Trans-Alaska Pipeline: Facts and Figures

The pipeline is 1287 kilometers long. Each piece is 127 centimeters in diameter.

The pipeline crosses 34 major rivers and streams and 3 mountain ranges.

Construction was started in 1973 and completed in 1977. The cost was \$8 billion.

The Trans-Alaska pipeline (in red) stretches from Prudhoe Bay to Valdez.

Above: the Yukon River, which flows east to west, is a major aquatic artery for the interior of Alaska and divides the state in half (north-south). The half-mile-long bridge built for TAPS and its haul road is the only road crossing of the river. The Arctic Ocean is 350 miles away and the state north of the Yukon is virtually roadless, except for the haul road. The Yukon Bridge is the largest of the thirteen TAPS bridges. The pipeline makes more than 800 river and stream crossings and it's buried under most of them, held down in a trench below the stream bed by large concrete anchors that straddle the pipe. 669

Above: caption: "The Trans-Alaska Pipeline crosses the Tanana River near Delta Junction, via a suspension bridge 1,299 ft. in length, which makes it the second longest pipeline bridge in Alaska"

Left: caption: "South Fork of the Koyukuk river with frozen overflow. James Dalton Highway and the Trans Alaska Oil Pipeline cross the river. Brooks range, Arctic, Alaska." 670



671



672

“...Back then, when a road was constructed in a permafrost region, standard practice was simply to gouge away the tundra until frozen ground was reached. When it melted, you moved over a few yards and scraped again. But during the pipeline construction, hardly a bulldozer blade touched the tundra. Instead, gravel, gathered from dry river beds and glacial moraines, was simply piled up to make a work pad about five feet above the tundra. When gravel became scarce, a gravel and polystyrene-foam ‘sandwich’ was used...”

Popular Science, April 1977

RE: construction of the Dalton Highway commenced on April 29th 1975 and, at the peak of the effort, APSC and their four subcontractors had more than 3,400 workers deployed from the Yukon River to Prudhoe Bay. A massive airlift of +700 flights per day (170K total) was necessary to supply the road construction effort. The road was finished on September 29th 1975. It had taken just 154 days to build the 360-mile-long gravel road. Final grading had to be done and more than 20 small permanent bridges were yet to be built, but by November 1975, the road was open to traffic (crossing the Yukon River on another ice bridge). In total, the new Dalton Highway cost \$185 million to build.

673



The Haul Road (now known as the Dalton Highway) follows the pipeline along its northern half. It was the first part of the pipeline to be built (in 1974) as it enabled materials and equipment to be moved north from the Yukon River, 358 miles from the top of the pipeline route in the oil fields of Prudhoe Bay. Originally, it was intended to be a private industrial road (in order to get Congressional approval to construct TAPS). However, it opened to the public in 1995, and is now Alaska State Highway 11 (AK 11), though it still remains mostly unpaved.

674



Above: caption: “The Trans-Alaska pipeline snakes its way to the North Slope next to the Dalton Highway north of Fairbanks, Alaska”

675



676



677

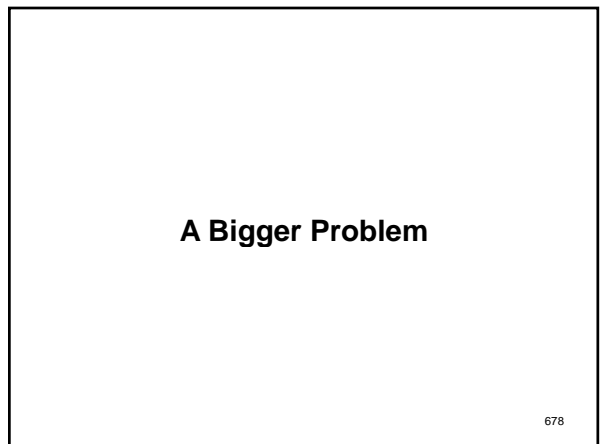

678

“...A Bigger problem along the route is erosion control, because:
 1) not enough is known about permafrost, and;
 2) enforcement is lax.
 ‘The state of the art was never equal to the project,’ said former pipeline monitoring engineer Gil Zemansky, 32, one morning across his kitchen table in Fairbanks. ‘We lacked real knowledge of Arctic conditions. We had to get it by trial and error’...”
 Popular Science, April 1977

679



“Supplies are once again being shipped to Alaska’s oil-producing North Slope after spring flooding forced 18 continuous days of impassable conditions on the Dalton Highway...The Dalton Highway is a 414-mile, mostly gravel road terminating in the industrial district of Deadhorse. The thoroughfare is essential for industry but is also important for tour companies and popular among sightseers and adventurers...Road work will continue throughout the summer as part of a \$27 million construction project awarded in January and expanded after the flooding. The project will raise the road’s grade three to seven feet and add culverts between mileposts 392 and 414...Problems have plagued the Dalton Highway since late March, when more than 2 feet of ice and water overflowed from the Sagavanirktok River. The highway, often called the Haul Road, was closed roughly one week, an unprecedented closure due to unprecedented flooding...The road reopened, but DOT knew spring thaw could again derail deliveries. Record-breaking temperatures in Barrow and much higher-than-average temperatures in the Brooks Range, which helps feed the river with snowmelt, rapidly melted ice built up on the road and caused the river to surge. More than 2 feet of water was flowing across the highway at times, causing severe erosion and tearing up tundra down to the permafrost. Crews were unable to begin repairs until waters receded, which finally happened on May 28. At various times high water stranded truckers, forced evacuation of worker camps, required sandbags and berms to protect Deadhorse Airport and briefly shut down a private road to Kuparuk Oil Field - the second largest field in the U.S...”
 newsmine.com, June 5th 2015

681



“...Chuck Champion, pipeline coordinator for the State of Alaska, agrees: ‘Probably the most troublesome area has been that of revegetation and restoration.’ He pauses and sighs. ‘Our effectiveness has not been what we hoped.’ ‘Just a couple of weeks ago, down below an active work pad, I saw a couple of stream courses that looked like chocolate milkshakes,’ adds Champion’s deputy, Cy Price. ‘We said to Alyeska’s man down there, ‘Whoa-up; implement proper erosion control methods.’ And he said, ‘I won’t unless you shut me down.’ ‘So we accommodated him’...”
 Popular Science, April 1977

684



"...The pipe itself will probably produce little melting, although it will be filled with 140-degree F oil that's hot enough to make soup of the permafrost. For half the route it sits atop horizontal supports (cost of each \$9,000) resting on deep, refrigerated pilings - 80,000 of them. The rest of the pipe is underground. The two modes alternate, depending on many factors, including wildlife-migration routes..."
Popular Science, April 1977

685

Concern No. 2

686



"...What happens when a pipeline crosses a caribou-migration route or a salmon spawning stream? Until recently, nobody knew; the pipeline made such questions vital..."
Popular Science, April 1977
 Above: caption: "A caribou stands beside a pipeline at one of the oil fields on Alaska's North Slope"

687



"...For example, the pipeline crosses scores of prime creeks, with the danger that it may block paths of migrating ocean fish or slosh silt into breeding sites. Alyeska has done both. 'So far as culverts go,' says engineer Zemansky, 'the problem is that Alyeska has consistently wanted to put in small culverts rather than bridges. They cost less. Frequently, in fact, the FWAT people (Joint Fish and Wildlife Advisory Team, an environmental group) would point out that a planned culvert was too small. But Alyeska would put it in, a washout would occur, and they'd have to bridge it after all'..."
Popular Science, April 1977

688

"The first pipe went in and there were dignitaries all around and everybody clapped and kind of walked away and they were almost gone when the concrete weight slipped off and she came up"
Bill Howitt, APSC Engineer
 RE: an empty pipe is buoyant thus, it had to be weighed down with a 7K-pound concrete "horseshoe." If it wasn't done right, the pipe would come floating to the surface. That's exactly what happened on the very first day pipe was laid in the *Tonsina River*.

689

"We counted until we got to 800 and called it that"
Ralph Jackson, SOHIO Engineer
 RE: besides the *Tonsina River*, APSC's engineers counted 34 rivers and 800 streams crossed. In some cases, the pipe was buried underneath the body of water, but in most cases it was elevated. In all, fourteen major bridges were built. Most bridge construction took place in the winter (to minimize disruption of migrating fish).

690

Almost Every Time

691

"...The siltation problem has been as bad, according to pipeline coordinator Champion: 'I feel that when it becomes necessary to shut down the project to stop Alyeska's work, we have, in essence, failed. But we've had to do that often, and almost every time its been for siltation...'"
Popular Science, April 1977

692

Best Laid Plans

693

"...It's not that the basic designs were necessarily wrong - even though many of them were developed on the spot. The problem is that plans weren't followed. And that applies even more to the question of animal crossings..."
Popular Science, April 1977

694

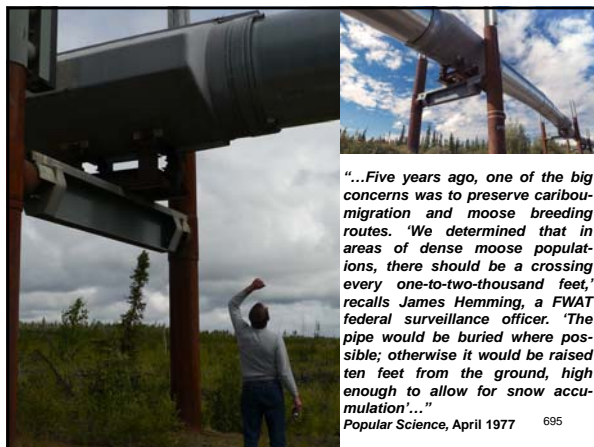

695

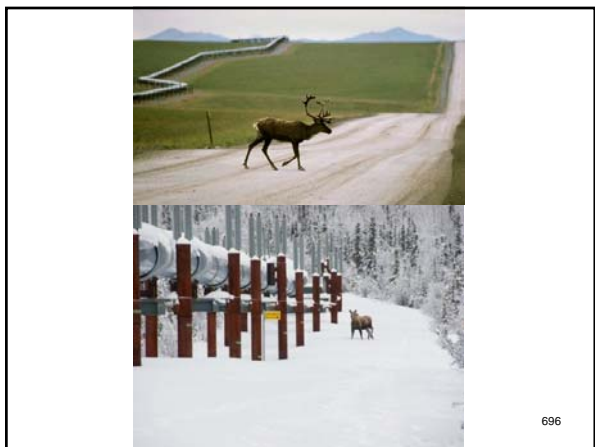

696



697



"...Final design called for 400 elevated placements, and everybody agreed to the specifications, including Dr. David Klein, caribou expert at the University of Alaska, Fairbanks: 'As the pipeline is now designed, it's good for animal passages as we know it'..."

Popular Science, April 1977
Above: caption: "TAPS - buried pipeline for animal crossing"

698



699

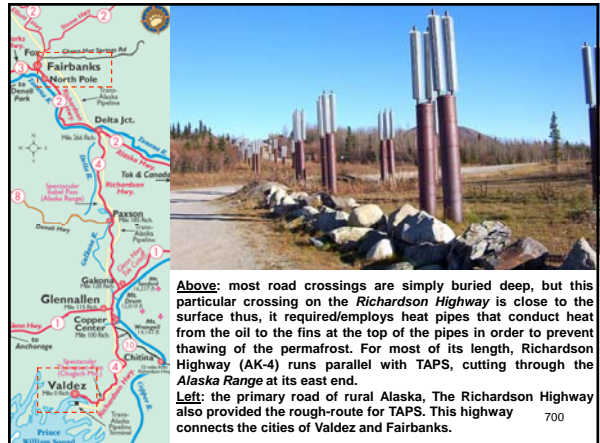

Above: most road crossings are simply buried deep, but this particular crossing on the *Richardson Highway* is close to the surface thus, it required/employs heat pipes that conduct heat from the oil to the fins at the top of the pipes in order to prevent thawing of the permafrost. For most of its length, Richardson Highway (AK-4) runs parallel with TAPS, cutting through the *Alaska Range* at its east end.

Left: the primary road of rural Alaska, The *Richardson Highway* also provided the rough-route for TAPS. This highway connects the cities of Valdez and Fairbanks.

700

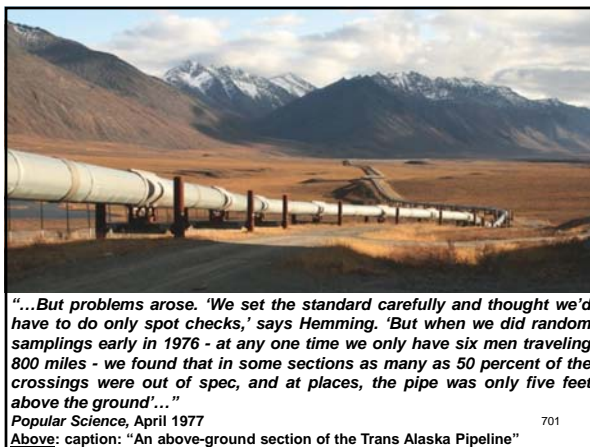

"...But problems arose. 'We set the standard carefully and thought we'd have to do only spot checks,' says Hemming. 'But when we did random samplings early in 1976 - at any one time we only have six men traveling 800 miles - we found that in some sections as many as 50 percent of the crossings were out of spec, and at places, the pipe was only five feet above the ground'..."

Popular Science, April 1977
Above: caption: "An above-ground section of the Trans Alaska Pipeline"

701

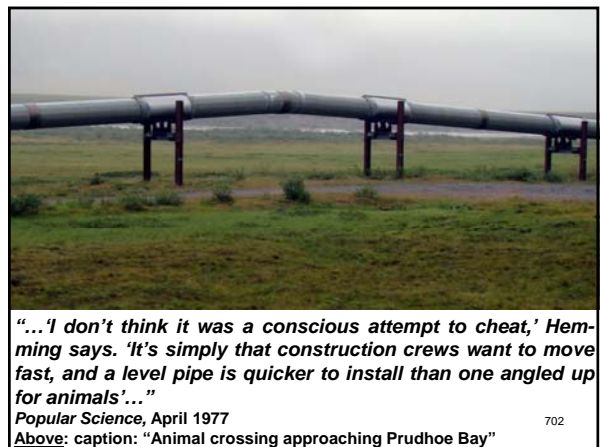

"...'I don't think it was a conscious attempt to cheat,' Hemming says. 'It's simply that construction crews want to move fast, and a level pipe is quicker to install than one angled up for animals'..."

Popular Science, April 1977
Above: caption: "Animal crossing approaching Prudhoe Bay"

702

Over or Under

703



"...But now, according to wildlife experts, most crossings are up to spec, with moose and caribou freely moving over or under. So that area of concern seems largely under control..."

Popular Science, April 1977

Left: caption: "Barren ground caribou, Rangifer Tarandus, migrate across the tundra north of the Brooks Range, Arctic, Alaska" 704



705

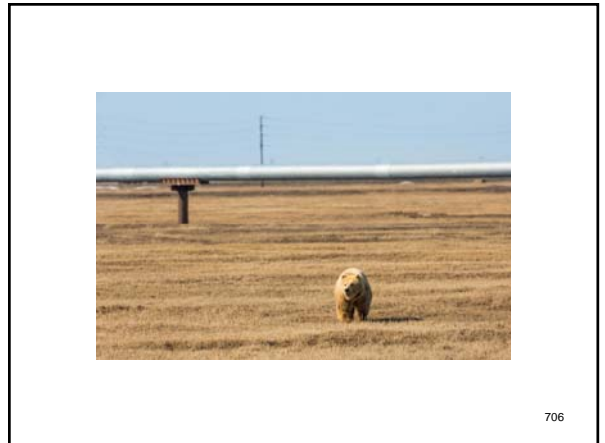

706

Part 11
Concern No. 3

707

How Could It?

708

"...If for some reason the pipe should burst, environmentalists envision the Alaskan landscape flooded with tens of thousands of barrels of crude oil. How could it break? One big worry is earthquakes. The line runs across a whole series of faults, one of which is the Denali, source of the disastrous 1964 earthquake. In the past 70 years, 23 violent earthquakes have rocked the pipe route..."

Popular Science, April 1977

709

No Worries

710

"...The builders, however, are not worried. 'When that big earthquake comes,' says Alyeska chairman Edward L. Patton, in his droll style, 'the pipeline is the only thing that will hold the state together'..."

Popular Science, April 1977

RE: TAPS was designed to withstand earthquakes within a range of 5.5 to 8.5 on the Richter Scale (varying according to estimated earthquake probability at points along its path). At the site believed to have the highest risk (where the pipeline crosses the Denali Fault Zone), the pipe is on lowered risers that rest on elongated skids, allowing for up to 20-feet of lateral, and 5-feet of vertical movement (a two-part system of "shoes" and "anchors" hold the pipeline in-place at weak areas, such as faults, allowing it to move enough so that it does not fall off its supports if/when the ground moves). In November, 2002, a M7.9 quake occurred along the Denali Fault, its epicenter fifty miles west of the pipeline. The pipeline moved 7-feet laterally and 2.5-feet vertically. Some of the support members of the pipeline were damaged, but no oil was spilled. The epicenter of the largest earthquake in American history (which occurred in March 1964) was near Valdez; TAPS' southern terminus, measuring 9.2 on the Richter Scale.

711



"...The line does seem designed to hold up against any likely quakes - to Richter 8.5 in the Denali area. For one thing, most of the above-ground section zigzag, both to allow for temperature-related expansion and contraction and for slippage in earthquakes. When the line is filled with oil, the heat generated by pumping and friction of oil movement can raise pipe temperature to 145-degrees F. The temperature of any pipe in winter, however, may sink to minus 70-degrees F. A straight line would pull apart under these strains, but the pipeline's flexible, zigzag line will only straighten a little, sliding sideways up to 12 feet on Teflon-coated pipe supports..."

Popular Science, April 1977

Above: caption: "View of the Trans-Alaska pipeline running over a mountain. The zigzag pattern must be used to allow for expansion and contraction."

712



Left T&B: caption: "Approximately 420 miles of the 800-mile TAPS was built above ground. In sections where the pipeline is elevated, a zigzag pattern is readily apparent. This configuration contributes to the flexibility of the line, converting the changes in line length to side-ways movement." Because the metals from which the pipeline is made expand and contract with changes in temperature (Alaska's temperature ranges between minus 60 and 35-degrees C), the pipeline had to be built to accommodate changes in length. TAPS engineers estimated that a 304-meter segment of pipeline could shrink by as much as 0.3-meter in the coldest weather and expand by an equal amount during the warmest season. If the pipeline were straight, even a small change in each segment of the pipeline could be disastrous (the pipeline would either snap if it contracted too much or buckle, if it expanded). To prevent the pipeline from breaking, the designers used a zigzag configuration. These bends help relieve the effect of contraction and expansion.

713



To accommodate the extreme temperature range, the pipe can expand 18-inches lengthwise. When pipes are buried beneath the ground, the weight of the soil keeps the pipe from expanding and contracting. However, 420 miles of pipe - over half of the total line - sit above ground. That pipe needs someplace to go when the temperature change causes expansion or contraction. Thus, the pipeline follows a zigzag configuration, converting lengthwise expansion into a sideways movement. Wider zigzags were added in the Denali Fault area to anticipate earthquake movement. If it were not for the zigzags, the 800-mile pipeline would have been only 789-miles-long.

Above: caption: "The trans-Alaska oil pipeline on remote wind-scrapped flatlands on Alaska's north coast near the Beaufort Sea"

714



Above: caption: "When the first warm oil was put in the pipeline during start-up in 1977, the above-ground pipe lengthened almost 4-feet per mile. A straight pipeline would not have the flexibility to absorb that much growth." 715



Above: anchor structure/s (highlighted), 700 to 1,800-feet apart, hold the pipe in position. Between anchors, which can be identified by their four supporting "legs" (the pipe can move sideways on its cross-beams a total of 12-feet in case of thermal expansion and contraction, and another 2-feet in case of seismic activity).
Left: caption: "The pipeline was mounted on posts above the frozen ground. The aluminum radiators on top of the posts conduct heat - lost from the pipeline - away from the soil." 716

Sideways Slippage

717

Strike-slip fault

"They started designing this pipeline in 1969. Personal computers didn't exist. You almost didn't have scientific calculators. It was slide rules and pieces of paper back then, but these guys were really pushing the frontiers of a lot of stuff including seismic design."
Bill Howitt, APSC Engineer

RE: when plans for TAPS were first drawn up, it was inevitable that the pipeline would have to cross the Denali Fault. The Denali Fault is one of the largest "Strike-slip" faults (above) in the world, equal in size to California's San Andreas Fault. Strike-slip faults produce earthquakes when tectonic plates on either side of the fault move horizontally against one another. Since the pipeline had to be elevated (above ground) as it traversed the fault (because of permafrost), Alaska's engineers came up with an innovative plan.

Above: caption: "The movement along a strike-slip fault is approximately parallel to the strike of the fault, meaning the rocks move past each other horizontally." 718



"...At the Denali Fault, support beams allow sideways slippage of 20 feet and a vertical drop of five. 'Any quakes that would disturb things more than that,' says Dennis Knottingham of R&M Consultants, an Anchorage bridge-design firm, 'are projected to happen only once every two centuries.' Adds Mr. Champion: 'You just couldn't develop a better system for handling earthquakes'..."
Popular Science, April 1977
Left T&B: caption: "Trans-Alaska oil pipeline at the Denali Fault crossing" 719



Above: as the elevated pipeline approaches the Denali Fault, it comes off its Vertical Support Members (VSMs), the H-shaped pilings that hold the pipe above ground in the permafrost zone. The pipe is placed in a steel shoe, which sits on top of a low-to-the-ground concrete beam. The bottom of the pipe shoe is covered in a slippery, Teflon-coated plate, allowing it to slide across the beam. At the Denali Fault, the pipe can slide up to 20-feet horizontally and 5-feet vertically. 720



721

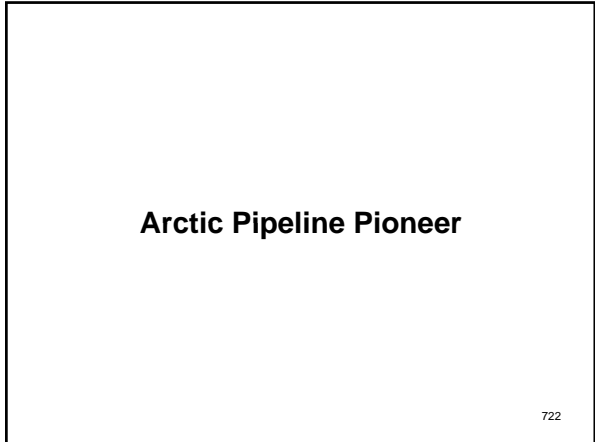

722

James A. Maple
P.E. Arctic Pipeline Pioneer
 1937 - 2001

Dr. Maple was a structural engineer and principal designer of the trans-Alaska pipeline. He holds three patents for his development of innovative pipe supports that enabled the warm oil pipeline to safely traverse areas of permafrost. He pioneered the use of sophisticated structural analysis for pipelines, now used on arctic pipelines worldwide. A graduate of Purdue University, he was a major contributor not only during design and construction but also continued to provide engineering expertise for the pipeline until his death in 2001.

In recognition of his contributions to the engineering of arctic pipelines, Dr. Maple was awarded the prestigious Harold R. Peyton Award for Cold Regions Engineering by the American Society of Civil Engineers in 2001. The award was named by Dr. Peyton, another key pipeline designer, who unfortunately died just before the pipeline was commissioned in 1977.

Dedicated August 1, 2002 in commemoration of the 25th anniversary of the opening of the Trans-Alaska Pipeline.

723



724

A photograph showing the interior of a museum exhibit. A large section of a pipeline is displayed on a raised platform. There are informational displays and a person looking at them.

Born in Rushville, Indiana, on April 22nd 1937, **James A. Maple** was the oldest of seven children. He was a major contributor to the engineering design of TAPS, receiving three patents for his development of innovative support systems that enabled the *Trans-Alaska Pipeline* to cross unstable permafrost zones. In 1992, he retired (with the rank of Commander, Naval Reserve) from the *U.S. Navy Civil Engineering Corps*. He died on August 13th 2001.

Above L&R: *James A. Maple Memorial* (left) at the *Trans-Alaska Pipeline Visitor Center* (right) in Fox, Alaska (just north of Fairbanks).

725



726

That's That

727

"...The pipe itself seems designed to withstand almost anything but an armor-piercing bullet at a one-foot range. 'But the gunman would be boiled in oil,' points out champion. 'The trajectory of the oil would be the trajectory of the bullet, and at a thousand pounds a square inch, that's that.'

Popular Science, April 1977

RE: on October 4th 2001, at the exact mid-point (Mile 400), a hunter named Daniel Lewis shot the pipeline while on a drunken ATV trip with his brother. The hole produced by his 0.338 caliber rifle caused a jet of oil to spray 75-feet out and nearly 300K gallons of oil were spilled onto the landscape. The pipeline has been struck by bullets several times. Usually, the half-inch-thick steel just indents. Acts of sabotage have also occurred. The largest single spill from the pipeline was in February 1978, when a bomb blast made a one-inch hole that resulted in 670K gallons spilled. The person/s responsible were never identified. As a result of this incident, Alaska Senator Ted Stevens successfully lobbied to have destructive acts against TAPS prosecuted as a federal offense.

728



729



730

If the Welds Hold

731

"...Aside from the risk of potshots, the half-inch-thick steel pipe seems sufficiently tough - if the welds hold..."

Popular Science, April 1977

732

May Have Been

733

"...The local papers headlined the story the day I arrived. Thousands of sections along the Alaska Pipeline may have been badly welded. May have been. Nobody was sure, because the inspection reports seemed to have been faked. Everybody was concerned: Alyeska Pipeline Service Co., the corporation in charge of building the line; government monitors; and environmentalists...For weeks after my visit to Alaska, newspapers headlined the complicated weld situation..."

Popular Science, April 1977

RE: welders were the highest paid of all TAPS workers, with a normal rate of \$18.25 per hour. To be hired, welders had to go through an intensive certification process that involved a series of test welds. If a welder failed any of the test welds, they were not hired and were not allowed to test again for several weeks.

734

At nearly 800 miles long, TAPS has been described as one of the most historic welding and construction projects in history. For three years, tens of thousands of welders and other workmen (i.e. teamsters, operating engineers, laborers etc.) braved the harsh climate and terrain of the Alaskan wilderness to join (by field welding) the 40-foot sections of 48-inch diameter pipe. Construction of TAPS began in 1975, a time where construction was in a slump throughout the U.S. as a result of the recession caused by the energy crisis. Because of this, the project attracted workers from all around the country. Due to of the immensity and importance of TAPS, the hiring process was very intense and carefully scrutinized. The first step of pipeline construction involved clearing the 800-mile path laid out by surveyors. Workers slowly trudged their way through forest, brush and obstacles using chainsaws and bulldozers. Once the path was cleared and approved by surveyors and engineers, holes were drilled and filled with gravel and water. These served as the foundations for the *Vertical Support Members* that held up the pipeline (using semicircular supports). The VSMs were carried by crane in 40 or 80-foot segments, lowered into the holes and then welded together. Quality control engineers inspected the welds using X-ray. With several VSMs already in place, workers officially laid the first portion of TAPS on March 27th 1975. Several 40-foot segments were placed atop the supports, welded together and coated in concrete. So began the two-year long process of welding on the pipeline. Putting together the necessary number of 40-foot sections of heavy wall steel pipe would require more than 108K perfect and often difficult "girth" welds by a small army of America's premier welders.

735

A Quick Review

736

"...Here's a quick review of the weld-inspection program Alyeska has instituted: A welding team working on a joint, followed by a radiograph team trained to take and interpret metallurgical X-rays. Then came repairmen to re-weld if necessary. Finally, a follow-up gamma-ray check was made. There was a hitch. Even with 20-hour workdays, the inspectors were lagging behind, and repair teams were falling even further behind (rejected welds sometimes reached 80 percent; 15 is about normal for pipelines). Meanwhile construction crews, who wanted to bury pipe quickly, put the pressure on..."

Popular Science, April 1977

RE: TAPS was unique among pipeline projects in that it required all welds of the main pipeline to be verified by X-ray. It was a time-consuming process and the quality-control procedures continually lagged behind the welders.

737

"...Someone from Alyeska's front office thought the crews might be too anxious, and to check, began to compare the welds with their X-rays. They didn't always jibe. It seemed that some flawed pipes were buried anyway, and a great number of pipe sections were buried without having been checked at all, with phony X-rays slipped into the record..."

Popular Science, April 1977

RE: to meet the unprecedented challenge of building an 800-mile long, 48-inch O.D. pipeline over some of the most forbidding and environmentally sensitive terrain in the world, a consortium of, initially, *Atlantic Richfield (ARCO)*, *Humble Oil (Esso)* and *British Petroleum (BP)* formed the *Alyeska Pipeline Services Company (APSC)* to build TAPS. As the weather warmed and work resumed on the main pipeline, APSC administrators were distracted by a controversy concerning pipeline welds that had been done the previous year.

738

What Elephant in the Room?

739

“...Though the findings were supposed to be confidential, word leaked out. Alyeska put on a corporate smile and stated things weren’t really that bad, that probably nothing was faked after all...”
Popular Science, April 1977

740



“...Then in June, a technician named Peter Kelley told a congressional subcommittee that he and his fellow workers had faked numerous X-rays on the order of a superior...”
Popular Science, April 1977
 RE: in September 1975, a former employee of *Ketchbaw Industries* filed suit against the company, alleging that he had been laid-off because he would not participate in a conspiracy to falsify quality control X-rays of pipeline welds
 Left: caption: “Welders working on a pipe”

741

Problem Welds

742

“...Alyeska decided to audit all welds made to date, and by May, 1976, had checked 30,800 of them at a cost of \$4.5 million. Findings: 3,955 ‘problem welds,’ 517 of which showed ‘uncorrected errors,’ and at least 475 radiographs either missing or faked (X-rays were matched by computer to catch duplicates)...”
Popular Science, April 1977
 RE: at the end of 1975, APSC terminated Ketchbaw’s contract and assumed responsibility for analyzing weld X-rays itself. However, the controversy continued as Kelley’s lawsuit moved forward. A Ketchbaw manager was found dead (of cyanide poisoning) and photographs of welds were stolen from a pump station construction camp. APSC began a review of all 30,800 welds that had been completed in 1975 and submitted its report to the *Department of the Interior* in April 1976. In May 1976, APSC submitted its technical analysis and a report on repair work underway. The review produced a list of 3,955 questionable welds for 1975. APSC reported that about half were too minor to affect the running of the pipeline, but questions remained concerning +1K welds that were suspicious. Re-examining the welds would be extremely difficult, since those sections of pipeline were sealed (very often, buried underground).

743

Bell-Holing

744

“...How to check the welds? One way: ‘Bell-hole’ the joints. Melt the ice with jets of steam, dig down around them, inspect the welds, perhaps make replacements - a minimum of \$9,000 for each pipe joint in flat ground, according to Alyeska’s Patton...”

Popular Science, April 1977

RE: by July 1976, Congress began holding hearings into the welding problems. POTUS *Gerald Ford* sent a team to Alaska to oversee and examine APSC’s work. At the recommendation of this team and to avoid further investigations, APSC began repairing the welds on its own.

745

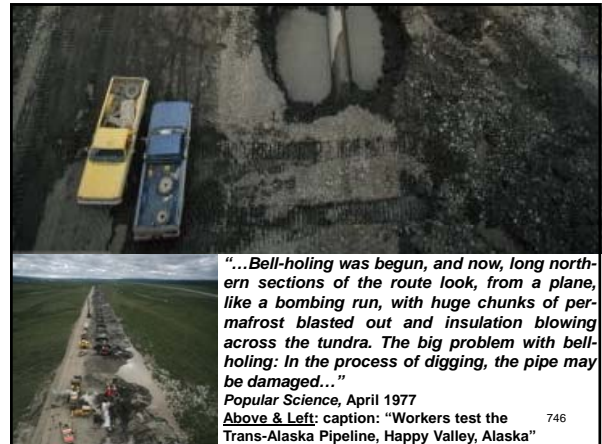

Hang-on Snoopy

747

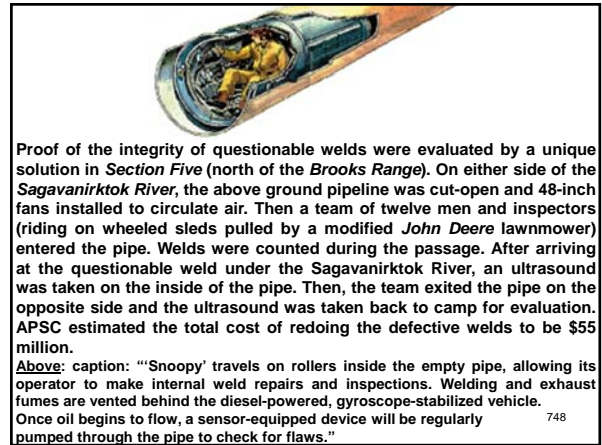

748

Completely Innocuous

749

“...By November 1976, Alyeska had repaired all but 34 of the questionable welds - even though two independent British testing organizations had reported that many of the welds contained only ‘completely innocuous’ minor irregularities. Based on this report, Alyeska asked the Department of Transportation to exempt 612 welds from repair. In the final ruling, only three of the welds were exempted; 21 others would have been left alone had Alyeska not exposed their joints...”

Popular Science, April 1977

RE: by September 1976, more than 3K of the questionable welds had been redone or certified as safe (APSC asked for waivers on the remaining 612 welds and more hearings resulted). By the end of November 1976, only 34 welds were still at issue. The leader of Ford’s team ordered 31 of the welds to be dug up and redone. Waivers were granted for only three welds, all of which were buried 17-feet under the *Koyukuk River*, south of the *Brooks Range*.

750

798ers

751

"Take your typical 798 pipeline welder and feed him a few drinks, and he'll probably tell you that he's God's greatest gift to welding"

Local 798 Welder

RE: members of the Plumbers and Steamfitters Union performed all welding that was not a part of the pipeline, including pump stations, feeder pipelines and work at the Valdez Marine Terminal. The welders who worked on the pipeline itself came from Pipeliners Local 798 out of Tulsa, Oklahoma, which specialized in providing welders for large-scale pipeline projects. Most 798ers were characterized by a heavy Southern accent, cowboy boots and distinctive welder's hats. They were the only workmen allowed to weld the 48-inch pipe of the main pipeline. Typically, outside observers characterized them as arrogant "rednecks." This superior attitude generated anger and resentment among other pipeline workers, often causing large-scale brawls. Too often, Alaska State Troopers had to be flown to pipeline camps in order to break up small riots. Toward the end of the pipeline project, a series of bumper stickers was produced with the slogan: "Happiness is 10,000 Okies going south with a Texan under each arm."

752



753

Pipeliners Local 798 out of Tulsa was founded in 1949 to oversee welding on cross-country pipeline construction in the U.S. and to serve as a clearinghouse for union welders specializing in pipeline construction. Welding on pipeline construction is considered by some to be something between an art form and an endurance run. It's both physically and mentally demanding, requiring an uncommon level of commitment and skill. Simply put, there's no margin for error when it comes to connecting pipe sections to be lowered into the ground, covered with earth and pumped full of highly pressurized and corrosive crude oil. Faulty welds will come back to haunt as "containment failures" - a pleasant term for the costly, messy and environmentally damaging leaks in a pipeline. This was particularly important in the remote, pristine and unique landscape of Alaska. The obvious choice for putting together the more than 100K sections of pipe was the 798ers; a group of journeymen welders who had spent decades refining and perfecting their skills as America's premier industrial welders.

754

Do Whatever it Takes

755



"Every weld was challenging in one way or another. The cold was always a big factor. The pipe sections had to be heated up in order to get a good weld. The lineup clamps would freeze to the inside wall of the pipe and we'd have to thaw them loose. The wind, the terrain, blizzards, everyday was a challenge. But the Alaskan landscape was wild and beautiful. Everyday we got up and went to work in the most wild, beautiful and often dangerous place anywhere in the world. It was a once in a lifetime experience."

Kevin Leeper, Local 798er

Above: caption: "Workers Align Trans-AK Pipeline for Welding AR AK Atigun Pass IPEL Site"

756

Throughout the TAPS project, there prevailed an essential "whatever it takes" attitude among the workforce. Whenever an impediment presented itself, the same attitude that had overcome environmental threats, the preservation of wildlife, organizational challenges, managing the ever escalating cost and more, the answer was always the same: *Do whatever it takes*. It was an attitude not lost on the +2K welders who were contracted through Tulsa-based *Pipeliners Local Union 798* to participate in what would prove, for most, to be the greatest challenge of both their life and career.

757



Throughout the TAPS project, welders worked inside protective aluminum enclosures that shielded them from the wind and other harsh weather conditions (it also provided the lighting they needed to work through the night). Similar to the VSMs, pipeline welds were also inspected using X-ray. Inspectors traveled alongside the welding crews in vans where X-ray film was automatically processed and inspected.

Left: caption: "A weld shack is moved toward a pipe joint during construction of the Gulf Coast Project pipeline in Atoka, Oklahoma"
Right: caption: "Quality control workers would indicate when a weld was X-rayed by writing on the support member"

758

Welds on the pipeline were originally expected to meet an average impact value of 20 ft-lbs. and, at a minimum, 15 ft-lbs. The joints were made using submerged arc welding and a wire that contained 3% nickel. About 80K-lbs. of such wire were used throughout the entirety of the TAPS project. Midway through the construction process, the *U.S. Department of the Interior* and a pipeline coordinating group representing the *State of Alaska* instituted more stringent requirements for weld toughness. Instead of the conventional electrode that was originally being used for the majority of field welds, new requirements necessitated a higher quality electrode (using an E8010-G filler metal) which had to be flown in from Germany). It was an electrode that most welders on the project had never used before.

759

"When I say Alaska was wild in those days, I mean it was wild. In those days the whole population of Alaska was probably 200,000. The pay was very good, the hours very long, the accommodations were adequate, the work was challenging, but everyone had that can-do attitude. We just keep at it and got it done."

Danny Hendricks, Local 798er

RE: as 798er legend goes, in the last days of construction, the last 1K-feet of pipe to be welded scaled a steep, jagged rock cliff at *Thompson's Pass*. It looked impossible and very dangerous. Nobody seemed very interested in climbing up a shear cliff with thousands of pounds of steel pipe swinging on a cable in a brutally cold wind with a steep drop thrown in for good measure. Not until *Junior Leslie* volunteered to "give it a shot." He'd come to Alaska to weld together a pipeline and the job wasn't quite finished - and he aimed to finish it (and, at the same time, restore Local 798's good name in the wake of the welding scandal). Inspired, other 798ers risked life and limb to join him on the last leg of TAPS.

760



Above: *Thompson Pass*, 776 miles downstream from Pump Station 1, is the crest of the last mountain range that TAPS oil has to flow over. The south face of the pass is nearly vertical in places, which made this the most difficult part of the pipeline to construct. Welders and equipment had to be dangled by ropes to work on the slope. From this point, the pipeline remains buried for its downhill, home-stretch, to Valdez.

Left: caption: "Construction workers weld the Alaskan pipeline before burying it underground during construction in Thompson Pass, Alaska, 1976"

761



762

A Never-Ending Scandal

763

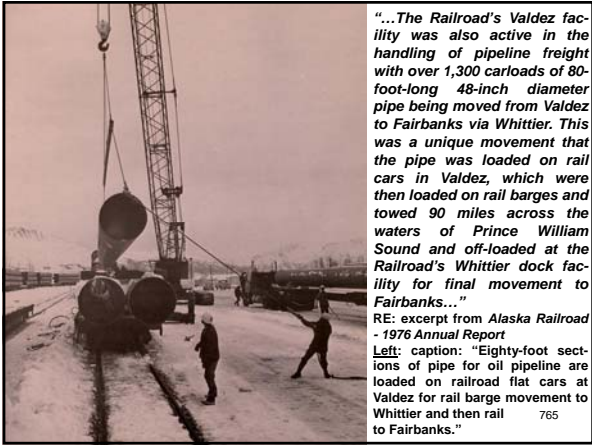
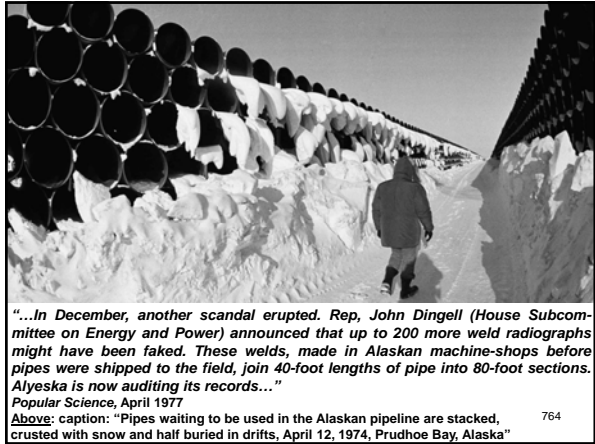

Discontinuities

766

In addition to producing high quality radiographs, radiographers must also be skilled in *radiographic interpretation*. Interpretation of radiographs takes place in three basic steps:

- 1) detection;
- 2) interpretation, and;
- 3) evaluation.

All of these steps make use of the radiographer's *visual acuity* (the ability to resolve a spatial pattern in an image). The ability of an individual to detect discontinuities in radiography is also affected by the lighting condition in the place of viewing and the experience level for recognizing various features in the image. Discontinuities are interruptions in the typical structure of a material. These interruptions may occur in the base metal, weld material or “heat affected” zones. Discontinuities, which do not meet the requirements of the codes or specifications used to invoke and control an inspection, are referred to as “defects.” The following discontinuities are typical of all types of welding.

767

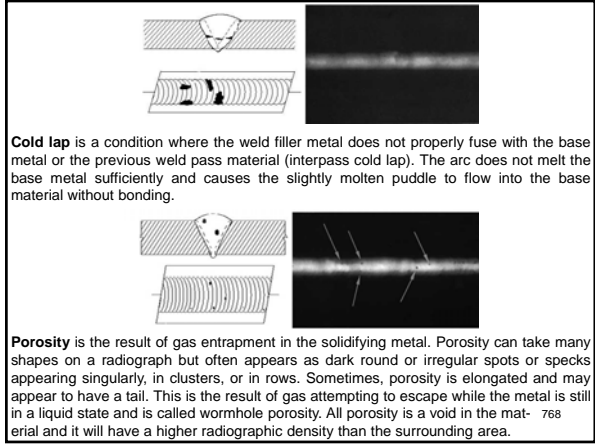

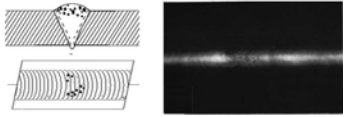

Cluster porosity is caused when flux coated electrodes are contaminated with moisture. The moisture turns into a gas when heated and becomes trapped in the weld during the welding process. Cluster porosity appear just like regular porosity in the radiograph but the indications will be grouped close together.

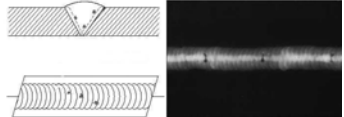

Slag inclusions are nonmetallic solid material entrapped in weld metal or between weld and base metal. In a radiograph, dark, jagged asymmetrical shapes within the weld or along the weld joint areas are indicative of slag inclusions.

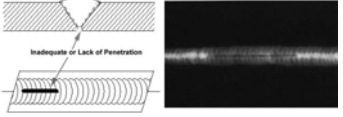

Incomplete penetration (IP) or lack of penetration (LOP) occurs when the weld metal fails to penetrate the joint. It is one of the most objectionable weld discontinuities. Lack of penetration allows a natural stress riser from which a crack may propagate. The appearance on a radiograph is a dark area with well-defined, straight edges that follows the land or root face down the center of the weldment.

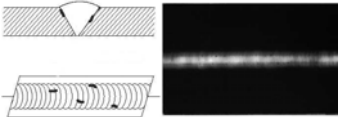

Incomplete fusion is a condition where the weld filler metal does not properly fuse with the base metal. Appearance on radiograph: usually appears as a dark line or lines oriented in the direction of the weld seam along the weld preparation or joining area.

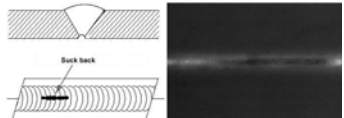

Internal concavity or suck back is a condition where the weld metal has contracted as it cools and has been drawn up into the root of the weld. On a radiograph it looks similar to a lack of penetration but the line has irregular edges and it is often quite wide in the center of the weld image.

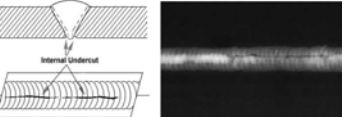

Internal or root undercut is an erosion of the base metal next to the root of the weld. In the radiographic image it appears as a dark irregular line offset from the centerline of the weldment. Undercutting is not as straight edged as LOP because it does not follow a ground edge.

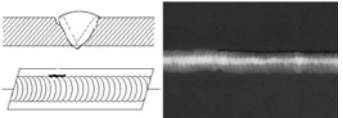

External or crown undercut is an erosion of the base metal next to the crown of the weld. In the radiograph, it appears as a dark irregular line along the outside edge of the weld area.

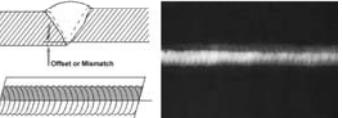

Offset or mismatch are terms associated with a condition where two pieces being welded together are not properly aligned. The radiographic image shows a noticeable difference in density between the two pieces. The difference in density is caused by the difference in material thickness. The dark, straight line is caused by the failure of the weld metal to fuse with the land area.

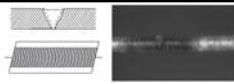

Inadequate weld reinforcement is an area of a weld where the thickness of weld metal deposited is less than the thickness of the base material. It is very easy to determine by radiograph if the weld has inadequate reinforcement, because the image density in the area of suspected inadequacy will be higher (darker) than the image density of the surrounding base material.

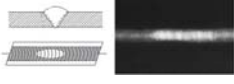

Excess weld reinforcement is an area of a weld that has weld metal added in excess of that specified by engineering drawings and codes. The appearance on a radiograph is a localized, lighter area in the weld. A visual inspection will easily determine if the weld reinforcement is in excess of that specified by the engineering requirements.

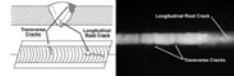

Cracks can be detected in a radiograph only when they are propagating in a direction that produces a change in thickness that is parallel to the x-ray beam. Cracks will appear as jagged and often very faint irregular lines. Cracks can sometimes appear as "tails" on inclusions or porosity.

Still More Problems

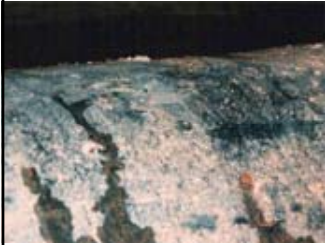

"...Still more problems: Inspectors are beginning to find pipe that was damaged while being buried, bent egg-shaped while being installed, or crushed by ice, equipment or back-fill..."
Popular Science, April 1977
 Left: caption: "Pipeline gouged and dented during excavation"

775

The Topper

776

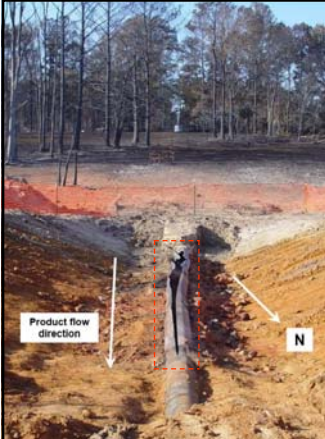

"...And what happened in mid-summer is the topper: a section of pipe exploded. Alyeska is required to test the whole pipeline hydrostatically; water is pumped into the pipe under pressure to check the welds. Rather routine. But this time, when the pressure gauge reached 187 psi, the buried pipe bulged, burst, flung earth skyward, and split down the middle, peeling back like a banana skin..."
Popular Science, April 1977
 Left: example of a burst underground pipeline

777

"...Alyeska explains that the gauges were clogged, that the pipe actually blew when pressure hit 1,560 psi. Independent metallurgists agree. The maximum oil pressure expected: 1,180 psi. Alyeska also notes that, even at these high pressures, there were no weld failures..."
Popular Science, April 1977

778

20/20 Foresight

779



"...But before bursting, the 18,000-foot pipe swelled, gaining 11 inches in circumference. Had the bloating weakened it? That whole pipe had to be replaced. Will other sections? And what will happen if the pipe bursts a year from now? If Alyeska's contingency plans work, probably not much. The entire line will be continuously monitored by a master computer at the terminus at Valdez. From 175 spots along the route, about 1,400 status signals will be reviewed every ten seconds, funneled into Valdez via microwave and satellite backup systems..."
Popular Science, April 1977
 Above: caption: "This photo shows the terminus of the 800-mile trans-Alaska oil pipeline in Valdez, Alaska"

780

"...If the computer detects something strange, an alarm will sound and an operator can then shut down any of the nine pump stations and 62 remote block valves, effectively isolating the problem area. Stations can be closed down in six minutes, remote valves in four, the whole line in ten. Along the route, 80 check valves automatically guard against backflow. When a leak is identified, the computer will print out a preplanned contingency outline, complete with crew and equipment identification..."

Popular Science, April 1977

781

Worst Case Scenarios

782

"...Total drainage will be limited to 'about 10,500 barrels on the average, with a maximum spill (which could occur at only one spot on the line) of 64,000 barrels,' states an Alyeska document. That's only for a 'significant' leak, however. Dingell's subcommittee was told that leaks up to 500 barrels a day could continue indefinitely without detection..."

Popular Science, April 1977

783



Above: caption: "March 2, 2006: A worker at Prudhoe Bay spots the frozen tundra drenched with some 200,000 gallons of oil. Unbeknownst to BP, one of the company's transit pipelines had become corroded and was leaking for days, resulting in the biggest spill ever recorded in an Alaska oil field. A pipeline detection system failed to catch the leak."

784

Hurry Up and Wait

785

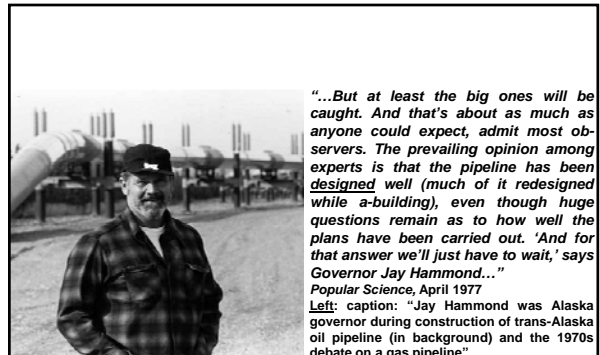

"...But at least the big ones will be caught. And that's about as much as anyone could expect, admit most observers. The prevailing opinion among experts is that the pipeline has been designed well (much of it redesigned while a-building), even though huge questions remain as to how well the plans have been carried out. 'And for that answer we'll just have to wait,' says Governor Jay Hammond..."

Popular Science, April 1977

Left: caption: "Jay Hammond was Alaska governor during construction of trans-Alaska oil pipeline (in background) and the 1970s debate on a gas pipeline"

786

Lessons Learned

787

"...Some conclusions, however, can be drawn now..."
Popular Science, April 1977

788

"...Inspection programs must be beefed up on any future project. To have only six FWAT inspectors to cover 800 miles, for example, is absurd..."
Popular Science, April 1977

789

"...Public environmentalists, especially in the beginning, were of immense help. Thornton Bradshaw, president of Atlantic-Richfield, admits that 'environmentalists blocked us for very good reasons...We didn't know how to make an environmentally safe line. They helped us'..."
Popular Science, April 1977

790

"...The 1977 deadline is too soon, construction too fast. Problems, as one congressional report states, stem from Alyeska's desire to 'complete a four-year project in three-years'..."
Popular Science, April 1977

791

"...The overall planning is good - even though much was developed as the pipe was installed. One fact-finding committee sent to Alaska by President Ford stated that the pipeline 'amounts to a monumental testament to American workmanship, not the monumental screw-up that's being charged.' At any rate, similar future private projects must have as much, if not more, scrutiny..."
Popular Science, April 1977

792

The Prophecy

793

"...All in all, the worries prevalent five years ago have been largely tranquilized. But in my travels across the state I found a new one starting to grow. Champion puts it this way: 'You know what I worry about? The tankers in Valdez harbor. The technological safeguards built into the tanker system don't approach the pipeline's. There's a tremendous amount of human error possible, and problems from a tanker spill, which I predict, will be of a magnitude greater than the worst case we might expect from the pipeline. And almost no one, really, seems to have too great a concern.'"

Popular Science, April 1977

794



Left: caption: "An oil skimming operation works in a heavy oil slick near Latouche Island in the southwest end of Prince William Sound on April 1, 1989"

Right: caption: "Three tugboats (right) push the oil tanker Exxon San Francisco (center) into place beside the crippled tanker Exxon Valdez (left) in Prince William Sound on March 30, 1989 to begin off-loading the remainder of crude oil in Valdez"

795



Top: caption: "Thick crude oil washed that up on the cobble beach of Evans Island sticks to the boots and pants of a local fisherman in Prince William Sound, Alaska on April 11, 1989"

Bottom: caption: "An oil cleanup worker walks through the oily surf at Naked Island on Prince William Sound on April 2, 1989 as beach cleanup goes on in background"

796

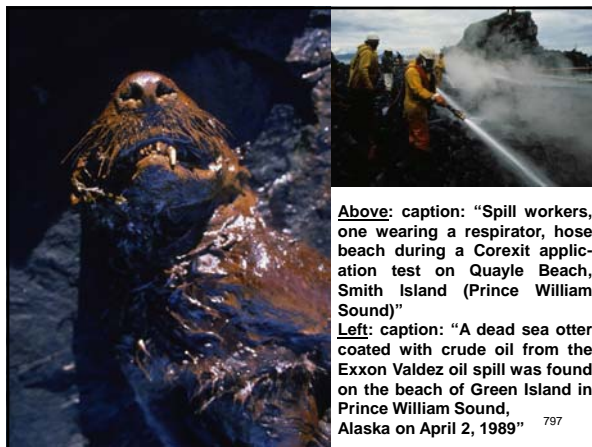

Above: caption: "Spill workers, one wearing a respirator, hose beach during a Corexit application test on Quayle Beach, Smith Island (Prince William Sound)"

Left: caption: "A dead sea otter coated with crude oil from the Exxon Valdez oil spill was found on the beach of Green Island in Prince William Sound, Alaska on April 2, 1989"

797



Left: caption: "Fishermen Greg Will (left) and Matt Kinney (right), both of Valdez, stand in protest outside an Exxon news conference room which was closed to local residents on April 2, 1989"

Right: caption: "Oily rocks glisten in the sun on Green Island (Prince William Sound). This section of beach, which was signed off as being environmentally stable by both Exxon and the Coast Guard, was re-oiled July 4, 1989."

798



Top: caption: "One baby and five adult oil-soaked sea otters lie dead on Green Island beach on April 3, 1989 in Prince William Sound"

Bottom: caption: "Clean-up workers scrub large rocks on the oil-covered beach of Naked Island in Prince William Sound on April 2, 1989"

799

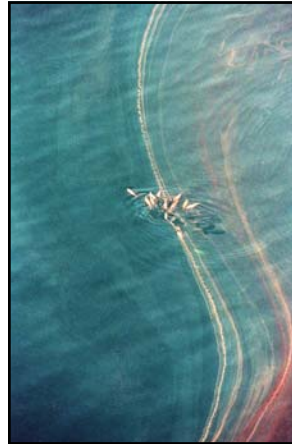

Above: caption: "Members of the Oil Spill Task Force during tour of facility, surrounded by large pile of oily waste - Dayville Incineration Site, Valdez July 4, 1989"

Left: caption: "A pod of sea lions swim through a slick of crude oil off the shore of Ingot Island, Alaska, Thursday afternoon, April 14, 1989, three weeks after the oil tanker Exxon Valdez spilled on Bligh Reef, March 24, and spilled nearly 11 million gallons of oil into Prince William Sound"

800



Left: caption: "Two staffers with the Alaska Department of Environmental Conservation are pictured patrolling the beach, May 1, 1989, in Anchorage, picking up oil-coated birds before they become toxic treats for predators. Steve Eng, left, and Max Schwenne were photographed on East Amatuli Island in the Barren Island group in the Lower Cook Inlet. That's about 225 miles from where the Exxon Valdez ran aground March 24, generating the nation's worst oil spill."

801



Above: caption: "U.S. petroleum giant Exxon Corporation shipping President Frank Iarossi comments on the cleanup operation 02 April 1989 in Valdez, a week after the beginning of an oil disaster"

Left: caption: "This March 26, 1989 photo shows the Exxon Baton Rouge (smaller ship) attempting to off-load crude oil from the Exxon Valdez after it ran aground in the Prince William sound, spilling more than 270,000 barrels of crude oil"

802



Top: caption: "In this June 23, 1989 photo, the Exxon Valdez is towed out of Prince William Sound in Alaska by a tug boat and a U.S. Coast Guard Cutter."

Bottom: caption: "A pylon marks the location of the Exxon Valdez shipwreck on Bligh Reef on April 6, 2004 near Valdez, Alaska"

803



Left: caption: "In this June 30, 2012 photograph, the Exxon Valdez is anchored some six nautical miles off the Bhavnagar coast near Alang ship-breaking yard in western Indian state of Gujarat, India. India's Supreme Court has allowed the Exxon Valdez, the oil tanker involved in one of the worst U.S. oil spills, to be dismantled in western Gujarat state."

804

Part 12

The Report Card

805

Introduction

806

OVERVIEW OF STUDIES OF THE LONG-TERM EFFECTS OF THE TRANS ALASKA PIPELINE SYSTEM ON FISH AND AQUATIC HABITATS
VOLUME 1
Prepared for
ALYESKA PIPELINE SERVICE COMPANY
By
AQUATIC ENVIRONMENTS INCORPORATED
J. Dembato
P. Hebert
April 1984 Anchorage, Alaska

"During the years 1981, 1982, and 1983, Aquatic Environments Inc. conducted a series of studies of aquatic environments and fish populations along the Trans Alaska Pipeline System (TAPS) north of the Yukon River. The report of these studies is presented in four volumes, of which this is Volume 1...The purpose of the study, which was commissioned by Alyeska Pipeline Service Company, was to document the present status of fish populations in the study area, to examine their responses to the pipeline and ancillary facilities, and to identify any positive or negative effects now that the pipeline has been in place and operating for several years..."

807

"...Many of the concerns addressed during the construction period involved short-term problems (eg. sedimentation, fuel spills, instream equipment operation) which are much less of a concern now that TAPS is in operation. While our study sought to provide an overview of these concerns, emphasis was placed on the effects of long-term habitat modification, particularly large-scale modification associated with materials sites in active streambeds. Since this topic was addressed to a limited extent in earlier studies...our research was designed to complement that done previously. It was the overall goal of the study to obtain sufficient information on the habitat requirements of the three most common fish species (Arctic grayling, round whitefish, and Arctic char) that the effects of habitat modifications on populations of these species could be assessed quantitatively..."

RE: excerpt from Overview of studies of the long-term effects of the Trans-Alaska Pipeline System on fish and aquatic habitats: Volume 1 – April 1984

808

"...The study was conducted in three parts. The first part was a Review of Existing Information, including both published and unpublished literature, and interviews with over 100 individuals knowledgeable about the construction process and the effects of the project on aquatic environments. The second part was a General Survey of Selected Streams, and was designed to provide an overall assessment of the status of stream habitats and fish populations north of the Yukon River. Most of the General Survey was conducted in 1981, but numerous incidental observations made during 1982 and 1983 have been included. The third part of the study, by far the largest and most important component, consisted of Detailed Studies of Representative Stream in the Northern District. During this part of the study, a dozen streams were studied intensively over the course of the three-year study period, enabling comparison among years of the effects of different weather conditions and variations in biological parameters..."

RE: excerpt from Overview of studies of the long-term effects of the Trans-Alaska Pipeline System on fish and aquatic habitats: Volume 1 – April 1984

809

"...Because they were designed to address concerns identified during the Review of Existing Information and the General Survey, the Detailed Studies were made up of a number of individual studies, each based on a particular concern. These included:

1. A study of benthic invertebrate communities (Atigun and North Fork Chandalar rivers, Falcon, Airstrip, Brockman, Snowden, Minnie, and Marion creeks);
2. A study of sedimentation originating from Atigun Pass (Atigun River and North Fork Chandalar River);
3. An examination of the taxonomy of Arctic Char;
4. A study of fish entrapment in materials sites (Holden, Trevor, Spike Camp creeks and North Fork Chandalar River);
5. A study of the modification of thermal regimes (Atigun, North Fork Chandalar, Dietrich, and Middle Fork Koyukuk rivers);
6. An assessment of fish habitat requirements (based on sampling in 27 stream reaches in 24 individual streams);
7. A study of fish habitat modification (Falcon, Holden, Trevor, Airstrip, Snowden, Brockman creeks and North Fork Chandalar River);
8. An examination of the effects of angling pressure (Oksrukuyik Creek).

In the following sections, an overview of the most important results of these studies is presented..."

RE: excerpt from Overview of studies of the long-term effects of the Trans-Alaska Pipeline System on fish and aquatic habitats: Volume 1 – April 1984

810

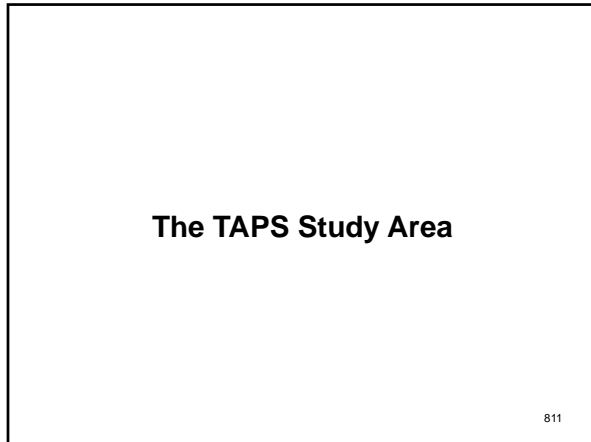

"...The TAPS Study Area was located within the Northern District, and extended from Prudhoe Bay to the Yukon River, an area where the TAPS right-of-way crosses more than 400 streams and intermittent watercourses (Figure 1). Many of these waterbodies support substantial migrating populations of Arctic grayling (Plate 1), the most abundant species in the area, and smaller numbers of Arctic char and round whitefish..."

RE: excerpt from Overview of studies of the long-term effects of the Trans-Alaska Pipeline System on fish and aquatic habitats: Volume 1 – April 1984

812

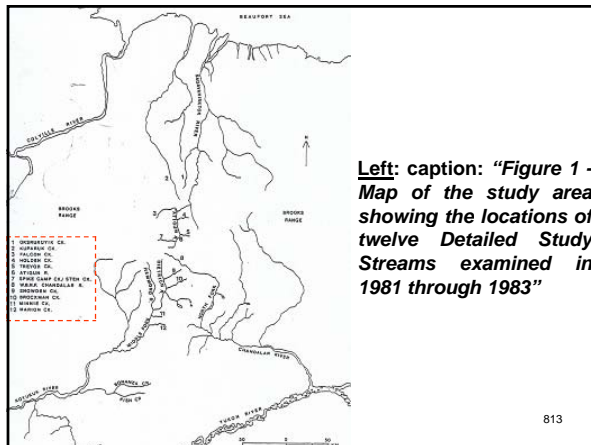

"...In this region, the pipeline route generally parallels portions of the Sagavanirktok, Atigun, North Fork Chandalar, Dietrich, and Middle Fork Koyukuk rivers, and is buried in the floodplains of each of these streams for considerable distances. In these areas, stream training structures (spur dykes) have been used to promote hydraulic stability and prevent channel migration over the buried pipeline. At those locations where the pipeline crosses a river or a stream, the pipeline has been either elevated or buried. Most of these crossings are overhead crossings, which were installed during the winter months when streams were dry or frozen to the bottom, and consequently had little effect on the instream environment..."

RE: excerpt from Overview of studies of the long-term effects of the Trans-Alaska Pipeline System on fish and aquatic habitats: Volume 1 – April 1984

815

"...Within the TAPS Study Area, the most extensive forms of instream disturbance occurs in materials sites (granular borrow sources) located within the historic floodplains both of major rivers and of some tributary streams. Surface scraping and pit excavation at these sites has affected areas up to 1 to 2 km in length, and necessitated the removal of both stream banks and bank vegetation (Plate 2)..."

RE: excerpt from Overview of studies of the long-term effects of the Trans-Alaska Pipeline System on fish and aquatic habitats: Volume 1 – April 1984

816



Above: caption: "Plate 2 - Trevor Creek (foreground), a tributary of the Atigun River (back-ground), showing the haul road, the pipeline, and a large instream materials site, MS-112-2 (light green area)" 817

"...The streams of the region were classified by McCart et al. (1972), according to their physical and biological characteristics, as Foothills Streams, Mountain Streams, and Spring Streams. Within the TAPS Study Area, most streams can be classified as either Foothills Streams or Mountain Streams. Spring Streams, which provide important fall spawning and overwintering habitat, particularly in tributaries along the east bank of the Sagavanirktok River, are uncommon inside the pipeline corridor..."
 RE: excerpt from Overview of studies of the long-term effects of the Trans-Alaska Pipeline System on fish and aquatic habitats: Volume 1 – April 1984

818

"...Foothills Streams, typified by Oksrukuyik Creek (Plate 3), generally originate within the Foothills Physiographic Province, both north and south of the Brooks Range. These streams are generally low-gradient, single-channel systems fed by surface runoff. Springs are rare in Foothills Stream drainages; but, where they do occur (eg. in Oksrukuyik Creek near Pump Station 3), braiding and icing formation in the winter usually coincide. Most of these streams cease flowing in winter, and receive only seasonal use by fish. Beaded pools and small intermittent lakes are common, the latter often providing the only fish overwintering habitat available in the watercourse..."
 RE: excerpt from Overview of studies of the long-term effects of the Trans-Alaska Pipeline System on fish and aquatic habitats: Volume 1 – April 1984

819



Above: caption: "Plate 3 - Oksrukuyik Creek, a typical foothills stream and a tributary of the Sagavanirktok River, near Pump Station 3" 820

"...Mountain Streams, typified by the Atigun River (Plate 4), originate in the Brooks Range, and include all the larger streams within the TAPS study area (eg. Sagavanirktok, North Fork Chandalar, Dietrich, and Koyukuk rivers), as well as the numerous smaller tributaries draining the Mountain Physiographic Province. These streams usually have high gradients and tend to become highly braided wherever valley floors are broad and flat. Groundwater from small springs is common, and generally forms substantial icings when flow persists into the winter. Surface runoff in Mountain Streams occurs only from late May until early winter and, with the exception of frequent freshets, tends to peak in early to mid June..."
 RE: excerpt from Overview of studies of the long-term effects of the Trans-Alaska Pipeline System on fish and aquatic habitats: Volume 1 – April 1984

821



Above: caption: "Plate 4 - The Atigun River headwaters near Atigun Bridge No. 1 (MP160. 0 in background). Violent freshets are common in Mountain Streams, typified by the Atigun River." 822

“...Fish inhabiting most streams in the TAPS Study Area are highly migratory, moving into tributary streams following breakup, remaining there for a three-month summer feeding period, and returning to deep pools in large streams, lakes, and groundwater sources to overwinter. The majority of the 400 stream channels crossed by the pipeline are either dry or frozen to the bottom in winter, and support no fish from early September until Late May. As a result, with the exception of the major rivers, pipeline routing has avoided most important overwintering areas in the region...”

RE: excerpt from Overview of studies of the long-term effects of the Trans-Alaska Pipeline System on fish and aquatic habitats: Volume 1 – April 1984

823

“...Table 1 summarizes information concerning the types of studies conducted in each of these 12 streams. Of the 12 streams, seven (from north to south, Falcon Creek, Holden Creek, Trevor Creek, Spike Camp Creek, North Fork Chandalar River, Snowden Creek, and Brockman Creek), are associated with major materials sites; two (Oksrukuyik Creek and the Kuparuk River) are typical Foothills Streams with overhead crossings; and two (Minnie Creek and Marion Creek) are typical Mountain Streams, the former with an overhead crossing and the latter with a buried crossing. The 12th stream, the upper Atigun River, was the site of reported fish entrapments, thermal irregularities, sediment introduction, and, in 1979, a crude oil spill...”

RE: excerpt from Overview of studies of the long-term effects of the Trans-Alaska Pipeline System on fish and aquatic habitats: Volume 1 – April 1984

824

Stream	MP	Form of Disturbance(s)	Reported Concern(s)	Typ
Oksrukuyik Creek	103.5	Overhead Crossing Light Angling Pressure	Undisturbed	Fis
Kuparuk River	126.4	Overhead Crossing	Undisturbed	Fis
Falcon Creek	uncrossed	Light Angling Pressure Instream Materials Site	Habitat Modification	Ben Fis
Holden Creek	145.7	Overhead Crossing	Fish Entrapment Habitat Modification	Ben Fis
Trevor Creek	154.1	Overhead Crossing Instream Materials Site Stream Channelization	Fish Entrapment Habitat Modification	Ben Fis
Spike Camp Creek	143.0	Instream Materials Site Extensive Armoring	Fish Entrapment	Fis
Atigun River	150-164.0	Instream Materials Site Oil Spill Draping Maintenance	Fish Entrapment Thermal Irregularities Sediment Introductions Oil Damage	Ben Fis Sed Mfg Tem
North Fork Chandalar River	167-173.0	Instream Burial Materials Site Draping Maintenance	Fish Entrapment Thermal Irregularities Sediment Introductions Habitat Modification	Ben Fis Sed Tem
Snowden Creek	186.5	Overhead Crossing Extensive Armoring Adjacent Materials Site	Habitat Modification	Ben Fis
Brockman Creek	204.1	Overhead Crossing Extensive Armoring Instream Materials Site	Habitat Modification	Ben Fis
Minnie Creek	225.4	Overhead Crossing Bank Armor	Undisturbed	Ben Fis
Marion Creek	233.2	Buried Crossing Extensive Bank Armor Long-term Impassible Culverts	Reduced Fish Use Habitat Modification	Ben Fis

Above: caption: “Table 1 - Summary of Detailed Study streams, forms of disturbance, reported concerns and the types of studies conducted from 1981 through 1983”

825

“...During the course of these studies, there was high variability in weather conditions, so that each of the streams was observed under a wide range of discharge conditions. In 1981, heavy rains during much of the summer caused high water levels and frequent freshets. The following two years were characterized by extremely low water levels, infrequent rains, and few, though relatively severe, freshets. Except for 1983, breakup occurred during the last week of May and the first week of June on the North Slope, and during the last two weeks of May on the South Slope. In 1983, an unusual warm spell caused considerable runoff in early to mid May. This period was followed by a protracted cold spell, which delayed complete breakup on the North Slope until the second week of June. Freezeup occurred in the third to fourth week of September in 1981 and 1982, but was generally 7 to 10 days earlier in 1983. In early September 1981, the abrupt onset of cold weather caused a rapid decline in water levels which had previously remained high all summer. In late August 1983, an even more severe cold spell (-10°C) caused considerable ice formation and loss of flow in both North and South Slope streams. This ice persisted until streams ceased to flow in early to mid September...”

RE: excerpt from Overview of studies of the long-term effects of the Trans-Alaska Pipeline System on fish and aquatic habitats: Volume 1 – April 1984

826

Effects on Benthic Invertebrates

827

“...Near watercourses, pipeline construction and its associated activities often result in localized sedimentation or erosion of streams, alterations in channel configuration, modification of granular deposition patterns, and localized changes to hydraulic configuration. All of these changes result in localized short-term shifts in the composition of the benthic invertebrate community. Most of these effects become less apparent with time, particularly when the source of disturbance (eg. instream equipment operation) ceases, and the watercourse stabilizes in a configuration comparable to that of the pre-construction environment. In the TAPS Study Area, most areas where streams were disturbed during the construction phase have been stabilized, and little erosion is now apparent. The majority of pipeline stream crossings, at least in the Northern District, are overhead crossings with stable armored banks, and were installed with little instream disturbance. In most instances, stream crossings were installed during the winter months when watercourses were dry or frozen to the bottom. Buried pipeline crossings, which are similarly well-armored, displayed little evidence of instability during the three years of the present study...”

RE: excerpt from Overview of studies of the long-term effects of the Trans-Alaska Pipeline System on fish and aquatic habitats: Volume 1 – April 1984

828

"...The most extensive streambed modifications occurred within the floodplain materials sites used to supply granular material for the construction of the pipeline and the haul road, and in areas where extensive bank armor or stream training structures had been installed to prevent scouring and subsequent exposure of the pipeline. The latter were used in highly unstable streams where an alternative to deep burial was required. In their natural state, these streams have highly braided floodplains, carry heavy sediment loads, undergo frequent channel migration, and support comparatively impoverished benthic invertebrate communities. In such areas, instream activity is less likely to have an adverse effect on benthic invertebrate populations than it is in clear, stable tributary streams, where organisms are not subjected to the rigors of the large braided mainstem streams..."

RE: excerpt from Overview of studies of the long-term effects of the Trans-Alaska Pipeline System on fish and aquatic habitats: Volume 1 – April 1984

829

Effects of Stream Crossings

830

"...Stream crossings in the TAPS Study Area include bridges, pipeline crossings, culverts, and low-water crossings (Plate 5). In this section, the post-construction status of each of these crossings is discussed. The most criticized stream crossing technique along the pipeline and its access roads is the low-water crossing, which is frequently used to cross small streams along the workpad. A review of JFWAT field surveillance reports from the construction period makes it apparent that these crossings were inadequate to handle heavy construction traffic without causing sedimentation, rutting of the streambed, deposition of cobble downstream of the crossing, blockage of fish passage, and habitat modification..."

RE: excerpt from Overview of studies of the long-term effects of the Trans-Alaska Pipeline System on fish and aquatic habitats: Volume 1 – April 1984

831



Above: caption: "Plate 5 - Typical low-water crossing with armored banks, widened pool at vehicle ford, and constricted outlet which helps prevent blockage at low flow (Polygon Creek, MP99.0)"

832

"...During the course of the present study, most observers interviewed agreed that, with the completion of construction, the number of problems associated with low-water crossings declined dramatically. The main reason for this decline was a decrease in vehicular and heavy equipment traffic along the workpad. Alyeska Pipeline Service Company does not allow vehicles to travel on the workpad during and immediately following breakup, a ban which prevents many of the rutting problems within streams. Moreover, now that the pipeline is operating, traffic is light, generally consisting only of those vehicles required for the inspection and maintenance of pipeline facilities..."

RE: excerpt from Overview of studies of the long-term effects of the Trans-Alaska Pipeline System on fish and aquatic habitats: Volume 1 – April 1984

833

"...Pipeline crossings are posing few problems during the operational phase of the TAPS Project. During an initial survey of 72 stream crossings located north of the Yukon River, no signs of significant fish passage problems, erosion, or instability were found. At all stream crossings examined, stream turbidity levels above and below the crossing were comparable. Where the pipeline was buried in large unstable floodplains, instream trenching did not appear to have increased instability, and stream training structures seemed to have limited channel migration in the most unstable areas. The liberal use of bank armor (rip-rap) on potentially unstable banks has also minimized problems. Although there were substantial washouts at MS-106-2, and at an unnamed stream (MP176.6) during this study, in neither case were the pipeline or its facilities the cause of the instability..."

RE: excerpt from Overview of studies of the long-term effects of the Trans-Alaska Pipeline System on fish and aquatic habitats: Volume 1 – April 1984

834

“...Culverts associated with the TAPS facilities are used at only a few locations along the workpad and on access roads, primarily to provide cross drainage. In general, these culverts posed no problems to fish passage, and were well-maintained and routinely de-iced during the present study. Culverts associated with the haul road were not specifically examined during this study; however, it was sometimes necessary to assess them in order to separate their effects from those of the pipeline and its ancillary facilities. Though there are still numerous impassible culverts along the haul road, an intensive program to replace the most troublesome culverts with bridges has been undertaken by the State of Alaska. Several culverts which were impassible in 1981 were replaced during 1982 and 1983, resulting in dramatically improved fish passage. In the Northern District, the majority of culverts where problems have been identified are slated to be replaced by bridges over the next three years...”

RE: excerpt from Overview of studies of the long-term effects of the Trans-Alaska Pipeline System on fish and aquatic habitats: Volume 1 – April 1984

835

Effects of Erosion and Sedimentation

836

“...Overall, sedimentation has not been a serious problem along the TAPS alignment since most access roads and the workpad are relatively stable with only a few localized erosion problems reported. Minor erosion was observed along the workpad at a few locations as previously noted, but generally only during severe freshets, primarily those associated with ice breakup in the spring. The Bureau of Land Management Office of Special Projects also noted a few minor erosion problems in their annual post-breakup inspection reports for 1981 through 1983. In no case do they indicate that these isolated incidents pose a serious environmental concern. In most instances, Alyeska has been prompt to respond to reported instability at stream crossings or along the workpad. Instability along the pipeline corridor within the Atigun Pass has resulted in increased sediment loadings in both the North Fork Chandalar River and the Atigun River (Plate 6)...”

RE: excerpt from Overview of studies of the long-term effects of the Trans-Alaska Pipeline System on fish and aquatic habitats: Volume 1 – April 1984

837



“...Fish habitat modification resulted from instream construction at pipeline crossings, access roads, culverts, low-water crossings, armored banks, stream-training structures, and materials sites. With the exception of the latter two, the amount of habitat lost or modified at any single location is extremely small. In many instances, minor modifications which increased stream depth, reduced velocity, created pool habitat, increased cover along banks (with rip-rap), or created uniform cobble substrates appear to have enhanced habitat in relation to the habitat preferences of the most common fish species. Indeed, many of these small disturbed areas (eg. low-water crossings, culvert plunge pools, pools created in armored banks) support a disproportionately high number of fish compared with adjacent undisturbed areas. In a few high-gradient streams (eg. Snowden Creek), large pools created by rip-rap at the pipeline crossing and the haul road culvert plunge pool occasionally support more fish than all other accessible habitats in the stream combined. Low-water crossings were frequently used by spawning grayling, since they provide low-velocity pool habitat during high discharge periods, and generally have uniform cobble substrates...”

RE: excerpt from Overview of studies of the long-term effects of the Trans-Alaska Pipeline System on fish and aquatic habitats: Volume 1 – April 1984

839

“...Of greater concern are the large-scale habitat modifications resulting from use of extensive bank armor, spur dykes, and instream mining of granular material...have already demonstrated that habitat modifications in instream materials sites located in the largest streams have caused changes in fish distribution and size composition (eg. Sagavanirktok River, Dietrich River, Middle Fork Koyukuk River)...suggests that some of these same types of habitat modifications may affect fish distributions and size composition in materials sites in the Atigun River drainage, and in the vicinity of spur dykes in the Middle Fork Koyukuk River drainage...”

RE: excerpt from Overview of studies of the long-term effects of the Trans-Alaska Pipeline System on fish and aquatic habitats: Volume 1 – April 1984

840

Effects of Habitat Modification

841

"...The conclusion of the studies summarized here is that, while there is some evidence of minor habitat modifications and localized reductions in fish density associated with a few spur dykes, there is no evidence that these modifications have had an adverse effect on overall fish population levels in the area...Overall, instream mining in tributary streams has resulted in increases in braiding, turbulence, and channelized areas; decreases in depth, average substrate size, and amount of pool habitat; and the elimination of banks, bank vegetation, cover, and velocity barriers (Plates 7 and 8)..."

RE: excerpt from Overview of studies of the long-term effects of the Trans-Alaska Pipeline System on fish and aquatic habitats: Volume 1 – April 1984

842



Left: caption: "Plate 7 - Undisturbed portion of Trevor Creek showing normal habitat development including winding configuration, boulder-controlled pools, and overhanging vegetation"

Right: caption: "Plate 8 - Mined and channelized reach in Airstrip Creek (North Fork Chandalar River tributary) showing straight channel configuration and the absence of distinct banks, overhanging vegetation, and pools"

843

Conclusions

844

"...Overall, fish populations in streams along the TAPS alignment in the Northern District appear comparable to populations reported prior to construction. With a few exceptions, principally associated with spur dykes and materials sites, species composition and distribution have been largely unaffected by TAPS facilities. There is still some restriction of fish passage due to inadequate haul road culverts, but measures are being taken by the State of Alaska to alleviate this concern..."

RE: excerpt from Overview of studies of the long-term effects of the Trans-Alaska Pipeline System on fish and aquatic habitats: Volume 1 – April 1984

845

Summary of Findings

846

“...The following is a brief summary of the more important findings of this study:

1. Regional fish population levels do not appear to have been adversely affected by TAPS.
2. There have been some localized changes in the distribution of fish in a few tributary streams. These changes have resulted primarily from habitat modification in materials sites and from blockages to fish passage at haul road culverts.
3. Stream training structures in large streams have caused channel diversion, habitat modification, sedimentation, and channel dewatering which appear to have resulted in localized shifts in fish distribution.
4. Habitat modifications in tributary streams appear to have caused the displacement of fish from previously occupied habitats rather than a reduction in the size of regional populations.
5. Summer feeding habitat for grayling is present in excess in the study area, and does not appear to be a significant factor controlling regional population levels...”

RE: excerpt from Overview of studies of the long-term effects of the Trans-Alaska Pipeline System on fish and aquatic habitats: Volume 1 – April 1984

847

6. The pipeline workpad and access roads are causing few problems for migrating fish. Low-water crossings, severely criticized during construction, appear to provide adequate fish passage now that workpad traffic is reduced.

7. Pipeline buried in the flood plains of major streams is causing elevated temperatures in surface flow which are attracting fish and delaying their late summer and fall emigration to overwintering areas. Losses of these fish are, however, probably small in relation to natural mortality.
8. Instream mining of granular materials has caused a wide range of long-term habitat changes in tributary streams, including reduced stream stability. This reduced stability is responsible for seasonal reductions in the benthic invertebrate community in at least one stream.
9. The use of extensive bank armor has caused localized shifts in the scour/deposition pattern in a few locations which have resulted in minor changes in benthic invertebrate communities.
10. Sediments originating from Atigun Pass are increasing the sediment load of both the Atigun and North Fork Chandalar rivers. These sediments, however, are having no effect on the benthic invertebrate community of the Atigun River, and only a localized late-season effect in the North Fork Chandalar River. Neither area is used by spawning fish...”

RE: excerpt from Overview of studies of the long-term effects of the Trans-Alaska Pipeline System on fish and aquatic habitats: Volume 1 – April 1984

848

11. The pipeline and associated facilities are well stabilized both at stream crossings and where the pipeline has been buried in floodplains. There is little evidence of slumping, erosion, or stream sedimentation which might affect fish habitats.

12. Entrapment of fish occurs as a result of discontinuous flow in several mined streams in the Northern District. All streams studied which display this problem appear to have some natural tendency towards discontinuous flow. In some locations, however, instream mining may have aggravated the flow problem, and contributed to the incidence of entrapment.

13. The relationship of instream disturbance to the major fish entrapments which occur periodically in the North Fork Chandalar River is unclear. The materials mining operation in the floodplain was small in terms of both its areal extent and the amount of material removed, and there was relatively little disturbance of stream habitats. Dewatering and entrapment now occur both upstream and down stream of the area of disturbance. The area may be naturally subject to dewatering, and entrapment may have occurred before the construction of the pipeline...”

RE: excerpt from Overview of studies of the long-term effects of the Trans-Alaska Pipeline System on fish and aquatic habitats: Volume 1 – April 1984

849

Acknowledgements

850

“...The authors wish to thank the large number of individuals in industry, government, academia, environmental consulting, and construction who provided their insights into the construction process and the ensuing effects on aquatic resources. While the opinions expressed were diverse and often contradictory, they were invaluable in designing various components of this study.”

RE: excerpt from Overview of studies of the long-term effects of the Trans-Alaska Pipeline System on fish and aquatic habitats: Volume 1 – April 1984

851

Constructive Criticism

852

“When you look at the environmental coalition that was focused intently on the pipeline...there are all kinds of different groups. Some of them are saying, no new construction anywhere...a fringe group. But there’s a vigorous debate of, are we trying to stop the pipeline in its tracks and have it not built, or are we trying to make a better pipeline...It’s a lot of people wanting a lot of different things.”

Joseph Pratt, Historian

RE: concerning TAPS, various environmental conservation groups had different objectives, but the project served to rally the environmental community in a way no other project had done previous to it. Their common goal was to challenge the government on legal grounds, using the newly passed *National Environmental Policy Act of 1969*. In 1970, as APSC was poised to start construction on TAPS, the environmentalists struck back, invoking the new environmental protection law.

853

“This to me is one of the more significant laws of the 20th century in impact, of basic balance-of-power changes between the builders and those who oppose them. New legal tools are put in the hands of people who have never had that kind of power to affect the outcome of these issues.”

Joseph Pratt, Historian

“The law has two primary purposes: one is to inform federal decision makers about environmental impacts of their actions before they decide to take the action, and the second is to involve the public in that discussion with the decision makers before the action is taken.”

Peter Van Tuyn, Conservationist/Attorney

854

“It demonstrates that this law, which is often by its opponents portrayed as a block to development, can actually be constructively used to make projects better.”

Peter Van Tuyn, Conservationist/Attorney

RE: environmentalists went to federal court claiming the oil companies had provided neither an adequate environmental impact study nor any alternative plans (as required by federal law). The judge ruled in favor of the environmentalists. For nearly four years, they were able to delay construction, until the oil companies came up with a comprehensive impact study and a design that took into account the environment and the need to protect wildlife.

855

Of particular concern to environmentalists was the protection of Alaskan wildlife. In particular, they had feared for large caribou herds, believing the pipeline would disrupt the animals’ migration routes. When APSC’s engineers designed the pipeline, they added 554 elevated sections (10-foot high) so the animals could cross *under it*. The pipe was also buried in twenty-three locations so the caribou could cross *over it*. Reports of how the caribou fared in the intervening years depend on who you ask. Oil industry experts say caribou populations have doubled, while some wildlife biologists say this could be due to long-term factors (i.e. climate change). Critics of the pipeline proposal repeatedly pointed out the largely unexamined risks of marine spills in the plan. On this there is unanimity in the opinion that the biggest oversight in TAPS was the ocean link between Valdez and the lower 48 states. In the aftermath of the *Exxon Valdez* oil spill in March 1989, some 32K people, including commercial fishers, food processors and Alaska Natives sought \$4.6 billion in punitive damages against *ExxonMobil*.

856

Part 13

Turning On the TAPS

857

An Outstanding Development

858



On May 31st 1977 the final pipeline weld took place. Pump station and terminal construction still needed to be completed, but the pipeline was able to be put into operation without them being completed. On June 20th 1977, pump stations began pushing oil from Prudhoe Bay across the great wilderness divide of Alaska on its way to Valdez and thence the lower 48. In August 1977, the tanker ARCO Jun-eau sailed out of Prince William Sound with the first load of oil that had traveled through TAPS. So impressive was the project and the welding done on it, that in 2002 the American Welding Society declared TAPS: "An Outstanding Development in Welded Fabrication." APSC was presented with an award and congratulated on the immense project they helped create. By law, APSC is required to remove the pipeline once oil extraction in Prudhoe Bay is complete. Improvements in reducing flow-rates seem to suggest the oil could be flowing through the pipeline until at least the year 2075 - a century after its construction began.

859

The Lead in the Pencil

860

"...Pump Station 3 at Mile 104 was definitely in use. The pumps are powered by jet turbine engines that sound like the runway at your local airport. To look at a pump station is to realize that the real line involved here is the 9 million barrels of black crude oil inside the pipeline, like the lead in a pencil..."

Orion Magazine

861



At the source in Prudhoe Bay, oil lies several thousand feet below the surface, sealed in and under pressure. When that pressure is released, the oil comes flowing out of a well. It's then channeled to the first of eight pump stations.

Left: caption: "This oil rig crew drill for more oil on the North Slope in Prudhoe Bay, Alaska, June 20, 1977. The first oil will enter the Alaska pipeline bound 800 miles south to Valdez, the southern end of the pipeline."

Right: caption: "Photographers and reporters tour Pump Station One, June 20, 1977, in Prudhoe bay, Alaska. Oil from the North Slope will start pouring from here on an 800-mile journey to Valdez."

862

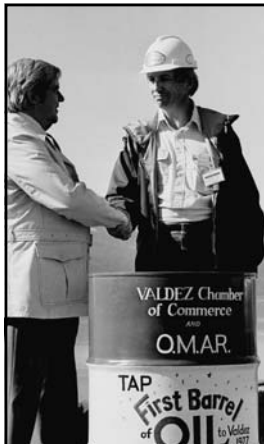

Pumps are required for two reasons. First, natural friction between the oil and the walls of the pipe means that some force is needed to move it along the line. Second, pumps are used to push the oil over mountain ranges (up to 4,800-feet above sea-level). The pump uses centrifugal energy to move the oil along. When the oil arrives at the pump station it is sucked into one of three pump units. Each unit has a pump impeller which twirls the oil rapidly. As the oil gains speed, it moves to the outer edges of the impeller blades. Then, it's drawn into a second impeller, gaining even more momentum. The oil is then forced back into the pipeline. The centrifugal force gives the oil both speed and pressure to flow up steep inclines.

Left: caption: "Henry Mowell, right, vice president of operations for Alyeska, turns over the first barrel of oil from the pipeline to Alyeska President William Darch during ceremonies, Friday, July 29, 1977, Valdez, Alaska"

863

Mile Zero and Beyond

864



Alyeska Pipeline Services Company operates Pump Station 1 (PS1) at the northern terminus of TAPS, measuring and taking custody of about one million barrels of oil each day from five different North Slope producers. APSC's stated goal is to measure, as accurately as possible, the inflow of crude oil; a task complicated by the fact that each stream comes in through each line at different pressures, temperatures and specific gravities (all within TAPS specifications). All raw measurements must be converted to gross standard volume so each producer can be fairly credited before the streams are combined and pumped south. In order to assure metering accuracy, a number of requirements for custody transfer metering instrumentation - meeting American Petroleum Institute (API) standards - are observed by APSC.

Left: caption: "Oil and gas pipelines run into Alyeska's trans-Alaska oil pipeline Pump Station One on Alaska's North Slope near Deadhorse, Alaska" 865

Right: caption: "Mile 0 of the 800-mile trans-Alaska oil pipeline on Alaska's North Slope near Deadhorse, Alaska" 865

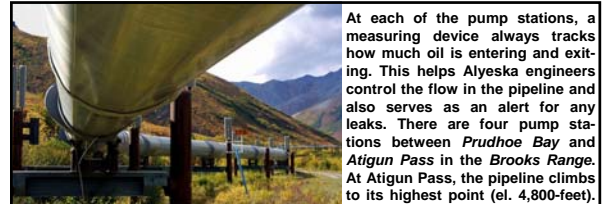

At each of the pump stations, a measuring device always tracks how much oil is entering and exiting. This helps Alyeska engineers control the flow in the pipeline and also serves as an alert for any leaks. There are four pump stations between Prudhoe Bay and Atigun Pass in the Brooks Range. At Atigun Pass, the pipeline climbs to its highest point (el. 4,800-feet). The oil then flows down into the Yukon Basin where it crosses the Yukon River, passes through Fairbanks and across the Tanana Flats. It then climbs again, up towards the Alaska Range.

Top: caption: "The trans-Alaska oil pipeline snakes across the Alaska wilderness 176 miles from Prudhoe Bay, Alaska, in Atigun Pass, Alaska"

Bottom: caption: "TAPS snakes across the Alaska tundra under the Brooks Range about 150 miles from Prudhoe Bay, Alaska" 866

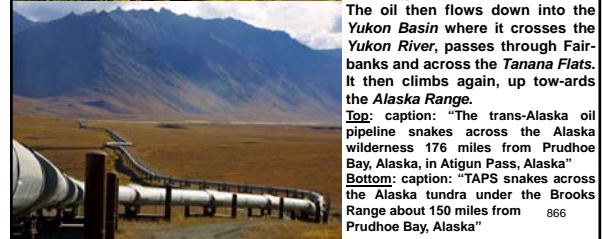

In the U.S., there are thousands of miles of pipelines carrying crude oil and other petroleum products to destinations throughout the lower 48 (mainland) states. While the oil begins its journey with major force, it loses forward momentum over time and distance. To overcome this, pumping stations are positioned throughout the length of the pipeline to adjust the pressure, pump the oil along the line and monitor flow and other information (in pipeline systems carrying Natural Gas, similar stations are located throughout the line to help push the NG along, but they're referred to as "compressor stations," not "pumping stations"). Pipeline pumping stations also increase the "through-put" of the pipeline. In other words, if a pipeline needs to be able to have a higher through-put capacity, another pipeline pumping station may be added to overcome the challenge. Pipeline pumping stations may be strategically located for their proximity to other equipment, or a pumping station may be constructed to help push the oil through a more difficult section of the pipeline (i.e. over a mountain range).

867

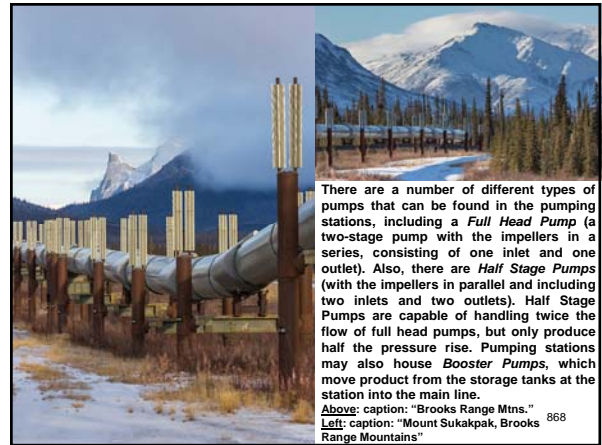

There are a number of different types of pumps that can be found in the pumping stations, including a Full Head Pump (a two-stage pump with the impellers in a series, consisting of one inlet and one outlet). Also, there are Half Stage Pumps (with the impellers in parallel and including two inlets and two outlets). Half Stage Pumps are capable of handling twice the flow of full head pumps, but only produce half the pressure rise. Pumping stations may also house Booster Pumps, which move product from the storage tanks at the station into the main line.

Above: caption: "Brooks Range Mtns." 868
Left: caption: "Mount Sukakpak, Brooks Range Mountains" 868

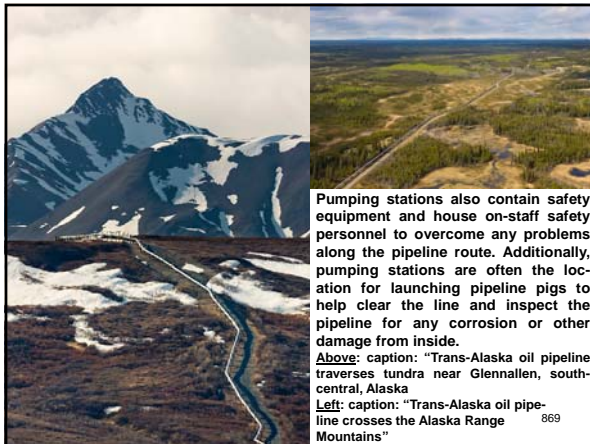

Pumping stations also contain safety equipment and house on-staff safety personnel to overcome any problems along the pipeline route. Additionally, pumping stations are often the location for launching pipeline pigs to help clear the line and inspect the pipeline for any corrosion or other damage from inside.

Above: caption: "Trans-Alaska oil pipeline traverses tundra near Glennallen, south-central, Alaska" 869

Left: caption: "Trans-Alaska oil pipeline crosses the Alaska Range Mountains" 869

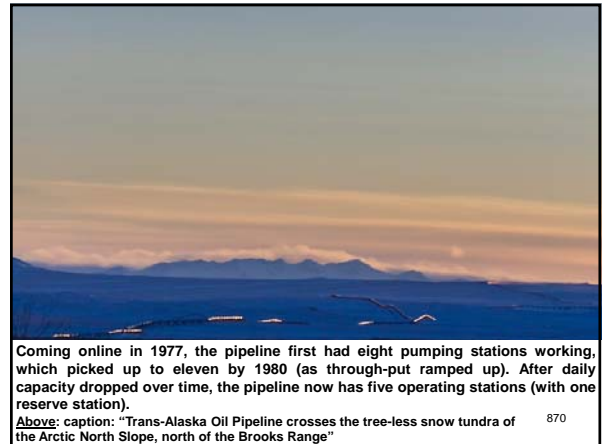

Coming online in 1977, the pipeline first had eight pumping stations working, which picked up to eleven by 1980 (as through-put ramped up). After daily capacity dropped over time, the pipeline now has five operating stations (with one reserve station).

Above: caption: "Trans-Alaska Oil Pipeline crosses the tree-less snow tundra of the Arctic North Slope, north of the Brooks Range" 870



Pump Stations 8, 9 and 10 (PS8-10) lift the oil through Isabel Pass. Then, the oil flows down into the Copper River Basin. With the help of Pump Station 12 (PS12), the oil makes its last ascent up through the infamous Thompson Pass. From the top of the pass, the oil then flows down to the marine terminal in Valdez. Once the oil arrives in Valdez, it is either loaded onto a tanker and transported to a refinery in the lower 48 states or housed in a holding tank until an empty tanker arrives. In its heyday (traveling at a speed of about 7 mph), it would take approximately four or five days for oil to travel the 800 miles from one end of the line to the other.

Left: caption: "Site of Pump Station No. 10, just north of the Denali Fault"
 Right: caption: "The trans-Alaska pipeline runs into the pump station near the Yukon River, north of Fairbanks, Alaska" 871

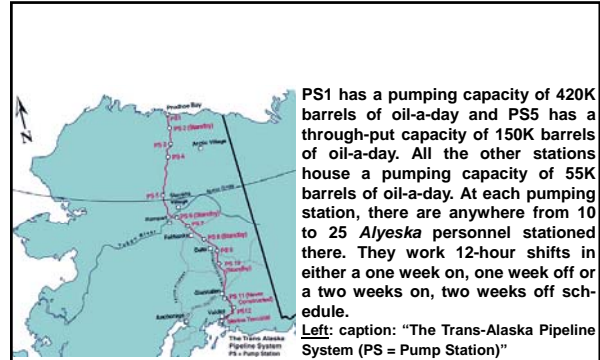

PS1 has a pumping capacity of 420K barrels of oil-a-day and PS5 has a through-put capacity of 150K barrels of oil-a-day. All the other stations house a pumping capacity of 55K barrels of oil-a-day. At each pumping station, there are anywhere from 10 to 25 Alyeska personnel stationed there. They work 12-hour shifts in either a one week on, one week off or a two weeks on, two weeks off schedule.

Left: caption: "The Trans-Alaska Pipeline System (PS = Pump Station)" 872

"..Deadhorse has virtually no permanent population, just six thousand workers at any one time in town on two-week shifts. There are no private homes, children, or schools. It's more like McMurdo Station in the Antarctic than anywhere else I've been..."
 Orion Magazine

873

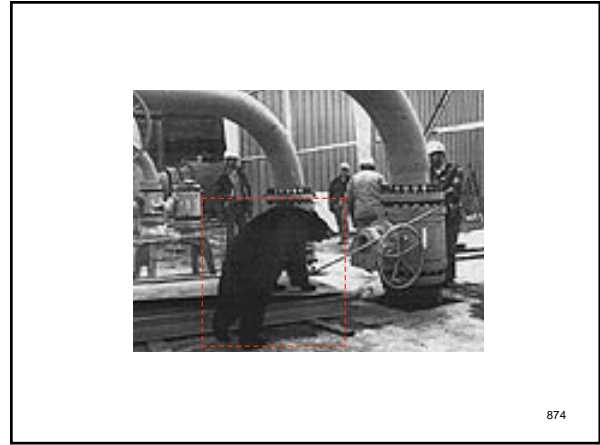

874

The Tail that Wagged the Dog

875

"...But if the oil pipeline has negative effects on Alaska's environment, it clearly will have positive effects on the state's treasury. When oil was discovered on the North Slope in 1968, the state sold oil and gas leases on 451,000 acres for \$900-million. But eight years later it had nearly used up the money and was forced to sell more leases to remain solvent. It also levied a 'reserve tax' on oil deposits and a property tax on the pipeline and related facilities. Alaska still owns the land it leased and is due to receive a 12.5 per cent royalty on the wellhead value of the oil produced at Prudhoe Bay. So the first year the pipeline becomes operational, the state estimates it will collect \$480-million in royalties and taxes. By 1980 the amount could increase to \$1-billion a year, if the pipeline production schedule holds up, and to \$2-billion by 1984. The exact amount the state receives, however, will be computed by a complex formula that involves a still-undetermined tariff on the North Slope oil. The state royalties will be based on the market value of oil at the wellhead minus the tariff. The tariff, to be set by the Interstate Commerce Commission, includes the costs of pipeline construction, amortization fees, operation and maintenance expenses, and related costs. So the higher the ultimate cost of the pipeline, the lower the state's royalties and revenues. The Alaska Department of Revenue has calculated that when the flow of oil reaches 1.2 million barrels a day, a difference of just one cent in the tariff per barrel would mean a gain or loss of more than \$1-million in state income..."
 CQ Press, December 17th 1976

876

"The Permanent Fund was an attempt to ensure that history of Alaskan resource exploitation did not repeat itself. It was an effort to reverse the tide of Alaska economic history. To try and keep more resources here and reduce the amount that flows outside."

Terrence Cole, Alaska Historian

RE: In 1976, shortly before the completion of TAPS, Alaska's politicians contemplated what to do with the expected windfall it would bring to state coffers. That same year, voters approved an amendment to the constitution to include the Alaska Permanent Fund (APF). The APF began accumulating hundreds of millions of dollars as royalty revenues started to roll-in from the oil companies operating the Prudhoe Bay Oil Fields. By 1980, it had surpassed the \$1 billion mark. Then, the Alaska State Legislature decided that every citizen of the state should get a piece of the pie. State politicians proposed a program called the Alaska Permanent Fund Dividend. Under this proposal, each resident would receive \$50 for each year they lived in Alaska. However, the U.S. Supreme Court found the proposal unconstitutional. As a compromise solution, every state resident would get the same amount. In 1982, the first dividend checks were sent out in the amount of \$1K. The dividend payments are based on a five-year average of the APF's earnings (which helps stabilize the dividends as the stock and oil markets fluctuate from year to year). In 2005, some 600K Alaskans received \$854.76.

877

Practically all Alaskan oil production is on state-owned land thus, the state receives revenue from four different sources:

- Production tax;
- Property tax;
- Royalties, and;
- Corporate tax.

Oil and gas revenues go directly into a general fund to be used for roads, health care facilities, schools and other social services. However, at least 25% of all mineral royalties is deposited into the APF. Former Governor *Jay Hammond*, who oversaw the APF's establishment, wanted to make sure the state didn't make the same mistakes it had when it received money from land leases to the oil companies in the late 1960s. Hammond often said that Alaskans had "900 million reasons" to vote for creating APF. What he was referring to was the \$900 million the state had received from its first big Prudhoe Bay oil lease sale (in 1969). Within a few years, it was all gone.

878

"...The revenues Alaska receives from oil and natural gas development may help revitalize the state's other industries. After petroleum, fishing and timber are the second- and third-ranking sources of income. However, both industries have suffered declines in recent years. Until the early 1960s, salmon fishing was the leading Alaskan industry. But it began to slump and the 1975 catch was only 26 million fish, down from 126 million in 1936. Logging also was strong until recently. The 1974-75 recession hurt lumber sales, and water-pollution regulations have threatened the closing of a major pulp mill in Ketchikan. But in the November 1976 election, Alaskan voters approved a ballot measure to create an Alaskan Permanent Fund which will be fed by at least 25 per cent of all mineral royalties, bonuses and income from lease sales. The fund will be used, among other things, to modernize the fishing and timber industries. State officials also plan to encourage new industries to locate in Alaska. They envision cement plants to lower the costs of construction, and petrochemical or plastics plants to use some of the oil and gas supplies. Already, an oil refinery is being built near Ketchikan, another is being planned near Valdez, and a fertilizer company at Kenai is completing a \$230-million expansion plan..."

CQ Press, December 17th 1976

879

"What has happened is that the dividend has become extraordinarily popular. The dividend has become the biggest single expense of state government. We decided to create a savings account, but the only thing we've agreed to do with it is to pay annual dividends. Since spending the earnings in any other way would reduce the dividend, there has been no support to do anything else with the fund. So that's the issue - the dividend has become the tail that wags the dog."

Terrence Cole, Alaska Historian

RE: by 2005, the Permanent Fund Dividend Division had paid out nearly \$14 billion. In January 2006, the state announced that it had amassed \$33 billion in mineral royalties. This money was invested in stocks, bonds, money market accounts and real estate.

880

To Stop the Rot

881



"Barely fourteen months after the 'Exxon Valdez' supertanker oozed 240,000 barrels of oil into Prince William Sound, Alaska finds itself mired in yet another environmental crisis: The fabled Trans-Alaska Pipeline is rusting..."

Popular Mechanic, August 1990

882



"...Completed in 1977 at a cost of \$7.7 billion, the 800-mile pipeline was supposed to remain corrosion-free for at least 30 years. But last year, the consortium that maintains the line, Alyeska Pipeline Service Co., unearthed 827 areas of probable corrosion. While much of the trouble is concentrated along a single 8-mile underground stretch near Brooks Range, isolated spots were found virtually the entire length of the pipeline..."

Popular Mechanic, August 1990

Above: caption: "Northern lights and Dalton highway, Brooks Range mountains in Alaska's Arctic"

883

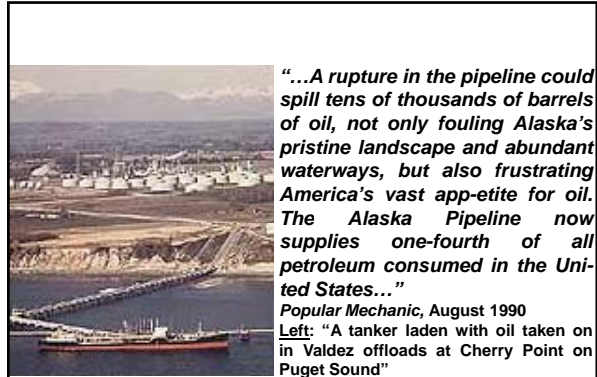

"...A rupture in the pipeline could spill tens of thousands of barrels of oil, not only fouling Alaska's pristine landscape and abundant waterways, but also frustrating America's vast appetite for oil. The Alaska Pipeline now supplies one-fourth of all petroleum consumed in the United States..."

Popular Mechanic, August 1990

Left: "A tanker laden with oil taken on in Valdez offloads at Cherry Point on Puget Sound"

884

No Bigger than a Quarter

885

"...Alyeska insists that a spill is not imminent. 'These are not the kinds of rust patterns that cause a total rupture,' says Bob Howitt, engineering manager for Alyeska. 'They're the kind that may cause a pinhole leak.' According to Howitt, many of the 827 suspect regions, or anomalies, could turn out to be nothing more than small dents, metallic inclusions or other non-threatening defects. Those anomalies confirmed as corrosion have typically been superficial, and no bigger than a quarter..."

Popular Mechanic, August 1990

886



"...Howitt maintains that even if the pipe ruptures, a major spill is virtually impossible. One-hundred fifty-one check valves would shut instantly if oil flow stopped or reversed, limiting the total possible spill from any single rupture to 50,000 barrels..."

Popular Mechanic, August 1990

RE: TAPS was designed with two types of safety valves. Seventy-one gate valves were designed to shut down the pipe within four minutes. Most were installed on flat terrain and downhill slopes near stream crossings, environmentally sensitive zones and towns. They can withstand temperatures as extreme as minus 70-degrees F. Additionally, eighty-one check valves were installed on uphill sections of the line to prevent oil from flowing backwards in the event of a break upstream.

Left: caption: "Trans-Alaska Pipeline, RGV 32"

887



888

The Daunting Task

889

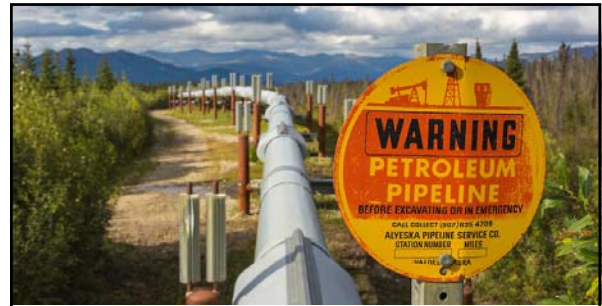

“...Of more immediate concern is the daunting task of repairing the corrosion. While the 48-inch-diameter pipeline runs aboveground on trestles for about half its length, virtually all of the corroded sections are buried in unstable permafrost. Thus, patching corroded areas necessitates not only welding on new steel jackets, but also excavating and reburying the pipe. The work will take years, and the cost will be staggering. Estimates range from \$600 million to \$1.5 billion. To date, only a fraction of the suspected corrosion spots has been repaired...” 890
 Popular Mechanic, August 1990

Pig Improvements

891

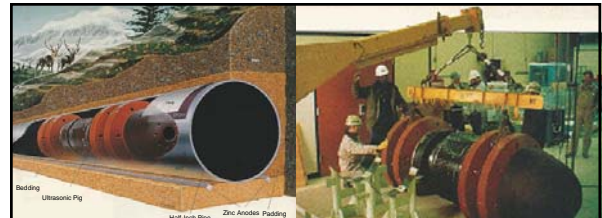

“...Although Alyeska claimed it had adequate rust detection systems when the pipeline opened, the severity of the corrosion went unrecognized until last year, when they began surveying the interior of the pipe with a new ultrasonic ‘pig’ manufactured by the Japanese firm NKK. Poking along at 90 percent of the oil speed (roughly 6½ miles an hour), this 11-foot, 6,600-pound, titanium-bodied submersible takes 255 soundings for each 15mm of forward travel. That translates into a mind-boggling 27 million readings for each mile of pipeline, all stored on ¼ inch magnetic tape...”

Popular Mechanic, August 1990
 Left: caption: “NKK pig travels the length of the Alaska Pipeline once a year, using its ultrasonic transducers to spot rust. Epoxy coatings and tape proved to be inadequate precautions on buried pipe.” 892
 Right: caption: “Ultrasonic pig is prepared for launch at a pipeline pumping station”

“...This huge volume of soundings gives the ultrasonic pig unprecedented sensitivity. Earlier pigs, which measured pipe-wall thickness with less sophisticated magnetic flux leakage technology, were blind to pipewall losses of less than 0.25-inch - 50 percent of the total pipewall thickness. The NKK pig picks up losses as small as 0.05 inch...”

Popular Mechanic, August 1990

893

“...Until the mid-1980s, Alyeska relied on magnetic pigs, built by Ipel (now Pipetronix) of Toronto, Canada. At that point, company officials decided they needed a more precise way to test the pipeline. Ipel responded by delivering an improved magnetic pig, capable of detecting pipewall loss of as little as 30 percent. On its debut run in 1987, the upgraded pig found 14 anomalies, none of which turned out to be actual corrosion. It was run again in 1988, and this time uncovered 241. Finally, in 1989, the ultrasonic pig made its first run. The data it produced were combined with the 1988 Ipel data to come up with 827 anomalies...”

Popular Mechanic, August 1990

894

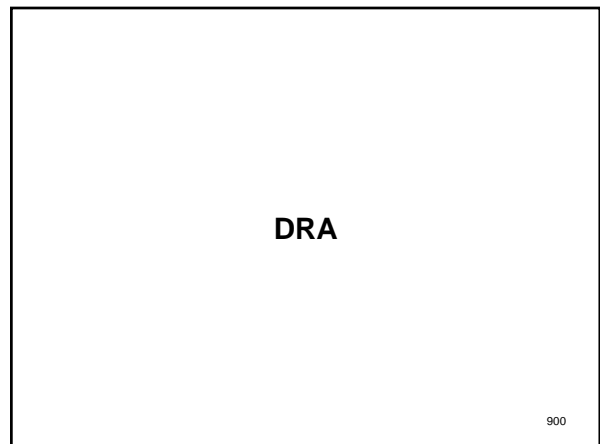
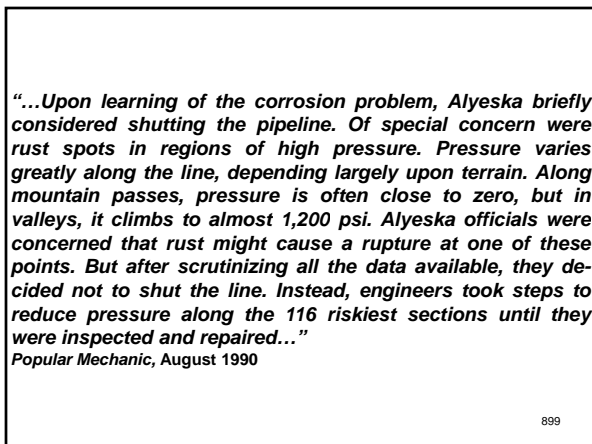
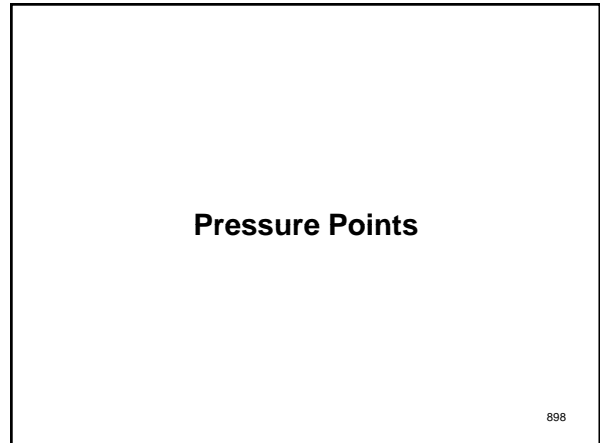
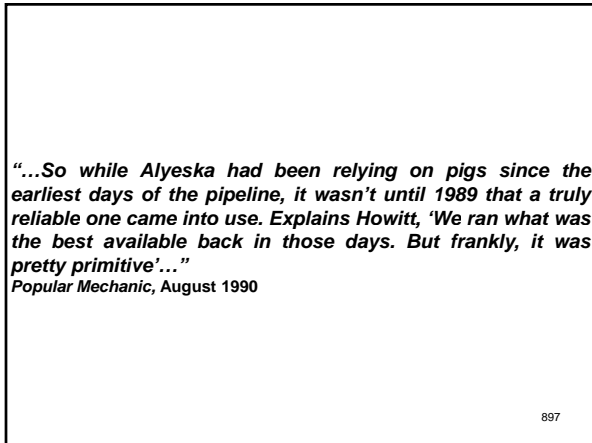
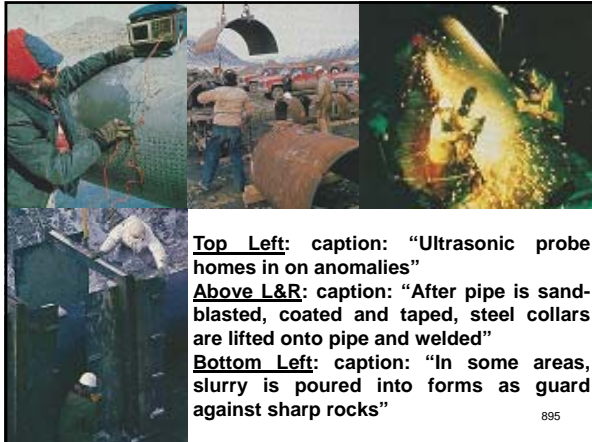

“...The primary means of pressure reduction was to use a long-chain polymer known as Drag-Reduction Additive, an STP-like friction-reducing agent. DRA enabled Alyeska to lower pressure levels significantly, while maintaining the standard flow rate of 2.1 million barrels a day...”

Popular Mechanic, August 1990

901

Corrosive Conditions

902



“...Oil pipelines are vulnerable to corrosion even under ideal conditions, but the environment spanned by the Alaska Pipeline is notorious for extremes. From the North Slope oilfields to the Valdez terminal on Prince William Sound, the line traverses barren plains, surmounts three major mountain ranges, fords countless streams and crosses the Denali fault, Alaska’s sole active geologic fault. Elevation ranges from sea level at either terminus to 4,800 feet, at Atigun Pass in the Brooks Range. Climatic conditions are equally inhospitable. During winter, the mercury often plunges to minus 70-degrees F, but it can spike to 90-degrees in summer...”

Popular Mechanic, August 1990

Above: caption: “Near the approach of Atigun Pass, Brooks Range, Arctic, Alaska”

903

The Engineering Challenge

904

“...The engineering challenge presented by such harsh conditions was further complicated by the temperature disparity between the pipe’s contents and the permafrost in which some sections are buried. Oil in the pipe can be as hot as 145-degrees F (it’s hot when it comes out of the ground). This thaws the surrounding permafrost, releasing moisture, which without adequate protection, causes rust. Thawing can also cause the soil beneath the pipe to subside, which can cause the line to buckle. Such subsidence along the Atigun Pass caused a bad spill in 1979...”

Popular Mechanic, August 1990

905

A Pipeline Delayed

906

"...Anxious to start construction, Alyeska acquired 800 miles of half-inch steel pipe in 1969 and 1970. But environmentalists doubts over the company's ability to build an ecologically sound pipeline prompted a spate of lawsuits. These delayed construction until 1974 - by which time the pipe had already begun to rust..."
Popular Mechanic, August 1990

907

Getting Ahead of the Curve

908

"...Once construction got under way, special precautions were taken. Existing rust was removed, and the pipe was heated to vaporize any remaining moisture. Then the pipe was coated inside and out with epoxy and three kinds of waterproof tape. Zinc rods were buried alongside the pipe. These 'sacrificial anodes' were supposed to prevent corrosion by minimizing current flow away from the pipe. In some areas, the pipe was buried in refrigerated trenches designed to keep thawing to an absolute minimum. Where even these precautions were deemed insufficient, the pipe wasn't buried at all, but suspended above the ground on trestles..."
Popular Mechanic, August 1990

RE: TAPS includes special corrosion protection. Zinc ribbons, which serve as "sacrificial anodes" (to inhibit corrosion of the pipe) are buried alongside the pipeline (an 8.5-mile *Atigun Pass* replacement section uses four magnesium ribbon anodes instead of zinc). The pipeline and zinc anodes pick up electrical (telluric) currents in the earth's surface, which are caused by the same phenomenon that generates the *Northern Lights*. The anodes act like grounding rods to safely return these currents back to the earth, reducing the risk of corrosion damage.

909



Above: caption: "The Northern Lights and the Alaska oil pipeline crosses the Dietrich river, Mount Dillon of the Brooks Range in the distance"

Left: caption: "The Northern Lights and the Alaska oil pipeline, Brooks Range in the distance"

910

Why?

911



"...Despite all the precautions, rust spots began to form. Why? Several explanations have been proposed. Alyeska maintains that the epoxy and tape failed to adhere properly. Others have suggested that rushed construction schedules and greedy contractors led to shoddy workmanship. So far, the state of Alaska has tentatively focused blame more squarely on Alyeska, citing imprudent design and construction as culprits..."
Popular Mechanic, August 1990

912

NOTE: "Alyeska" is a Native Alaskan (Aleut) word meaning "Mainland"



"...Whatever the real reason for the fiasco, state and federal officials overseeing the line have expressed concern about Alyeska's ability to effect repairs and prevent future corrosion of the pipeline. So have environmentalists. Says one, who would speak only off the record: 'I wouldn't trust Alyeska on this one. They promised they could clean up an oil spill with no difficulty, and look what happened with the Valdez.'"

Popular Mechanic, August 1990

Above: caption: "Alyeska workers do service maintenance on the Trans Alaska Oil Pipeline in Atigun Canyon, Brooks Range, Arctic, Alaska" 913

Slope Stability

914

As with any pipeline (especially one of this magnitude), TAPS requires continuous monitoring. To ensure that the pipeline is stable and well maintained, surveyors have regularly monitored TAPS since its initial construction. Monitoring "slope stability" is one of the most important activities APSC has regularly performed since startup in 1977. Normal geological activity could potentially damage the pipeline. Therefore, every year APSC conducts slope stability surveys at six key locations on the pipeline (from about 35 miles south of Glenallen to 75 miles north of Fairbanks). Most of these sites are located on southern hillsides where sun exposure is greatest (in areas known for ice lenses below the pile supports). These lenses can melt, causing hillsides to migrate down slope as much as 0.2-inches per year. Historically, the horizontal and vertical monitoring of the six sites took five crew members about twenty-one days using optical surveying instruments and methods (requiring separate horizontal and vertical surveys). In 2005, Anchorage-based CMSI-Bell J.V. developed a plan to reduce the hours of labor required to complete the survey. CMSI-Bell J.V. is a joint venture between *Chugach Alaska Corporation* (an Alaska Native Corporation) and *F. Robert Bell and Associates* (an Alaskan Civil Engineering and Surveying firm).

915



CMSI-Bell J.V. proposed using 3D scanning technology to complete the original scope of work as well as to potentially provide additional data that could be used in monitoring these sites. One of the first steps in setting up the surveys was to visit each location to determine if 3D scanning was practicable. The sites ranged from 700 to 5K-feet horizontally and 300 to 950-feet vertically. CMSI-Bell J.V. combined the use of GPS with 3D scanning technologies to produce a single point monitoring system and a point cloud-based surface mesh-3D model monitoring system.

Left: caption: "CMSI-Bell surveyor Greg Johnson shields the Trimble 3D scanner from rain in order to survey TAPS at Lost Creek Hill, approximately 80 miles NE of Fairbanks, Alaska"

916

The firm had previously completed a three-year project to gain vertical bench marks along the entire pipeline with an 800-mile static survey using GPS. The bench marks were also referenced with state plane coordinates (they used this control for the scanning project). Comparison of the historical data to the scanned data was accomplished by locating the historical monitor points, which were located horizontally and vertically in separate locations on the pipeline support structure. The scanned data was cross-referenced to historical data that had been collected with optical instrumentation and procedures. During the first scanning pass, the surveyors had to set up targets at both of these locations as well as the new single monitor point location. This step was taken to ensure a smooth transition from the old to the new data and to ensure that any previous reports and/or studies could be directly related to the new monitor points as well.

917

Apples-to-Apples

918

"We found additional uses of scanned data, including determining the skew or tilt of the vertical support members without making another site visit"

Chris Burt, CE - CMSI-Bell J.V.

RE: scanning results were able to be easily combined with historical points, which meant that the standardized monitoring reports and databases did not need to be redesigned when incorporating new data. This permits a direct "apples-to-apples" comparison when looking at the slope stability data over the lifetime of the project. As well, the ground surface mesh for future monitoring meant that APSC engineers could now compare the surface annually at these sites to help study the problems in more detail.

919

Part 14

A Never Ending Story

920

Boom or Bust?

921

"...Alaska today is a state of change and turmoil. The trans-Alaska oil pipeline - perhaps the largest private construction project ever undertaken - is nearly finished, and it already has altered Alaska profoundly. The pipeline has brought millions of dollars and thousands of people to the state, creating a 'boom' atmosphere unseen since the gold rush days. It remains to be seen if a 'bust' will follow. There are several competing plans to build another pipeline from Alaska's North Slope to carry its enormous natural gas reserves to market. If the 'haul road' that parallels the oil pipeline north of the Yukon River is opened up to the public, the northern half of the state will be significantly affected. As for the southern part of the state, Alaskans voted in November to move their capital from Juneau, in the southeastern panhandle, to a new site near the tiny town of Willow, just north of Anchorage and nearer the bulk of the state's population. On the site, a new city will be built so the capital can be moved by 1980..."

CQ Press, December 17th 1976

922



"At first, they thought the new oil field held about nine million barrels of oil, but it proved to hold much more and be the nation's largest oil field"

Curtis Thomas, APSC Corporate Communications Manager

RE: the Prudhoe Bay Oil Field, owned by British Petroleum, ExxonMobil and Conoco Phillips (with the thirteen North Slope oil fields operated by BP Exploration (Alaska) Inc.) is now estimated to hold at least 25 billion barrels of oil (one barrel equals about 42 gallons). The field has produced +1.5 million barrels a day in past years. In more recent years, output has been +/-850K barrels a day, or about 17% of domestic oil production. The pipeline is now a central part of an immense infrastructure covering 5K acres of the North Slope. Prudhoe Bay now includes 3,898 exploratory wells, 170 drilling pads, 500 miles of road, 1,100 total miles of pipeline (including feeders), five docks, and 25 production, processing, sea water treatment and power plants.

Left: caption: "Pipe array in the Prudhoe Bay oil field, Alaska"

923



924

The Big Picture

925

After the discovery of oil 1968, several oil firms, including: *Humble, Atlantic, BP Pipeline, Amerada Hess, Home Pipe Line, Mobil Pipe Line, Phillips Petroleum* and *Union Oil Co. of California*, formed a joint venture for a planning study and for engineering, design and construction of the *Trans-Alaska Pipeline System (TAPS)*. The pre-construction planning was itself an immense project, taking six years. A \$2.2-million archaeological survey by the *University of Alaska* and *Alaska Methodist University* excavated approximately 330 sites. Surveying the soil from *Prudhoe Bay* to *Valdez* involved 3,500 bore holes and approximately 15K soil samples. A total of 515 Federal and 832 State permits were required for right-of-way and other purposes. Approximately two-thousand contractors and sub-contractors were selected. Five contractors were each given responsibility for different sections of the pipeline. These were: *Morrison-Knudson-Rivers, Perini Arctic Associates, H.C. Price, Associated Green and Arctic Constructors*. A total of 70K contractor personnel worked on TAPS over the life of the project; from 1969 to 1977. At its peak (October 1975), the project involved 28,072 personnel, including APSC employees and contractors. There were thirty-one fatalities directly related to the construction effort.

926

Up and Over

927



"Up and over is a lot shorter than around and about. The construction was remarkable because we crossed some of the most hazardous, delicate and environmentally sensitive terrain in the world."
Curtis Thomas, APSC Corporate Communications Manager
 RE: TAPS planners chose a direct route south. This meant first going over the *Atigun Pass*, which at 4,728-feet. was the highest point on the pipeline and later crossing the *Isabel Pass* (3,566-feet) and *Thompson Pass* (2,810-feet). The pipeline would also cross three major mountain ranges (*Brooks, Chugach and Alaska*). The oil is pumped over the mountains hydraulically (i.e. four pump stations successively raise the pressure of the oil to pump it over the Atigun Pass).
 Left: caption: "The Trans-Alaska oil pipeline, Atigun canyon, Brooks Range, Arctic, Alaska."

928



929

A Pipeline Cuts Through It

930



Fourteen temporary airfields were built. Seven of these were 2,500 to 3K-feet long and seven were 5K-feet long (two of the latter continue to be used for the pipeline). Between 1974 and 1977, contractors built 29 construction camps. The largest of these (at the *Valdez Marine Terminal*) held 3,480 beds. The largest on the pipeline itself (at *Isabel Pass*) held 1,652 beds. More than 225 access roads were built, linking State roads with the pipeline, pumping stations and airfields. Thirteen bridges also were built for the pipeline system, including two suspension types in which the pipe is suspended from large steel cables draped over towers and anchored to massive foundations on opposite banks. The *Tanana River* suspension crossing is 1,300-feet long. Left: caption: "The Trans-Alaska Pipeline crosses the Tanana River via a suspension bridge 1,299 ft. in length, which makes it the second longest pipeline bridge in Alaska" 931

Timeline

932

The first 48-inch diameter, 5-inch thick pipe section actually arrived at Valdez (from Japan) in September, 1969. As the project picked up steam, the *Trans-Alaska Pipeline Act* became law in 1973, a federal right-of-way grant was issued in January 1974 and a \$150 million, 360-mile road (now known as the *Dalton Highway*) was built from *Prudhoe Bay* to the *Yukon River* between May and September 1974 (to supply the *North Slope* facilities). The first pipe was laid at the *Tonsina River* on March 27th 1975; the official start of actual construction. The pipeline bridge over the *Yukon River* (the only span across that river in Alaska) was completed on October 11th 1975. By October 26th 1975 the pipeline project was 50% complete. The first crude oil flowed through the pipeline from *Pump Station 1* (PS1) on June 20th 1977. Oil, natural gas, water and sediments, pumped from wells, were sent through pipelines to processing plants to be separated. The oil, gathered in tanks at the station, was then pumped through the pipeline. At Valdez, the oil was loaded on the tanker *ARCO Juneau* on August 1st 1977 (18 storage tanks at Valdez can hold 9.1 million barrels of oil). Valdez serves as the operations control center for TAPS. Three million tons of materials, including pipes, were shipped to Alaska for the pipeline system. The project used a total of 73 million cubic yards of gravel. A total of 42K double joint welds and 66K field girth-weld were used on TAPS. 933

New Discoveries

934

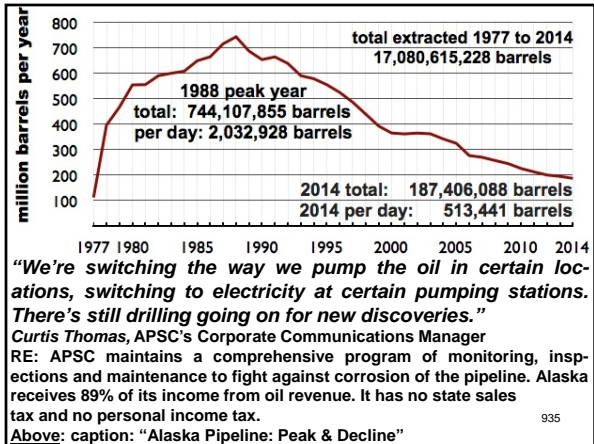

The Vault

936

"Alaska means 'The Great Land.' It is indeed a state of superlatives, Alaska is larger than the next three largest states combined. It has more timber, water and copper than the rest of the United States. There may be as much oil and natural gas in Alaska and off its coasts as in all the other 49 states. Alaska has three million lakes, several major river systems, a dozen peaks higher than any other American mountains, and numerous mammoth glaciers. Alaska's fish, wildlife, plants and flowers are abundant and many are unique to the state. Yet most of Alaska still is wilderness - of the state's 375 million acres only about 100,000 acres now are taken up by cities, towns, villages, roads or other marks of human activity. It has the fewest people of any state (405,000) and the most land per resident (925 acres)..."
 CQ Press, December 17th 1976

937

"...The state is investigating ways to tap economically its large reserves of iron ore, copper, zinc, tungsten, fluoride and gold. In addition, Alaska is believed to have at least one trillion tons of coal - enough to supply the nation for nearly two-thousand years at current consumption rates. But most of the known deposits are in such isolated and barren areas that mining and transportation would be extremely difficult..."
 CQ Press, December 17th 1976

938

Caption: "Alaska: A Vault of Potential Energy. Before the turn of the century, Eskimos unknowingly hinted at the immense energy stored beneath Alaska. To Russian and American whalers they described mysterious black lakes that burned. The discovery of North America's largest oil field at Prudhoe Bay in 1968 dramatically confirmed the 49th State's energy stores. Yet the 200-square-mile field, with estimated reserves of 9.6 billion barrels, would not satisfy our nation's oil appetite for even two years. No one really knows the extent of Alaska's total energy resources. Estimates of the amount of undiscovered recoverable oil range from 12 billion to 76.1 billion barrels, and natural gas estimates vary from 29 trillion to 439.6 trillion cubic feet. In addition, the state contains enormous amounts of coal, as well as uranium and geothermal and hydroelectric energy..."

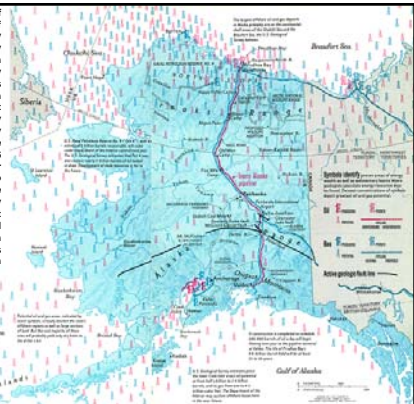

Above: map and caption from an article appearing in the November 1976 issue of *National Geographic* magazine entitled: "The Pipeline: Alaska's Troubled Colossus"

939

A Cautious Approach

940

Alaskan Facts and Figures



Area: 586,412 square miles, larger than Texas, California and Montana combined.
 Shoreline: 33,904 miles, about 38 per cent of the total U.S. shoreline.
 Continental Shelf: 560,000 square miles, about 65 per cent of total U.S. continental shelf.
 Climate: Relatively mild and wet in southern parts of state; extremes of summer and winter temperatures in central regions; arctic climate on North Slope.
 Time Zones: Four—Pacific, Yukon, Alaska and Bering.
 Major Resources: Oil, natural gas, fisheries, timber, copper, gold, coal, iron, water.
 Population: Approximately 405,000 in 1975, including 60,000 resident native Eskimos, Aleuts and Indians, according to state estimates.
 Capital: Juneau, to be changed to Willow by 1980.
 Governor: Jay Hammond (R), elected to four-year term in 1974.
 State Legislature: 40-member House of Representatives, 20-member Senate.

"...A consortium of eight oil firms is building the 800-mile trans-Alaska pipeline. To convert more of the state's energy potential to man's use, some Government officials believe 7,500 miles of pipeline and 6,000 miles of highways may be needed in the future - 'a future we may not want to see,' says Governor Jay S. Hammond, who advocates a cautious approach to development."
 RE: excerpt from map-caption from an article appearing in the November 1976 issue of *National Geographic* magazine entitled: "The Pipeline: Alaska's Troubled Colossus"

941



"...The state also plans to encourage its agricultural potential in an effort to reduce the high cost of food in Alaska. The Matanuska Valley northeast of Anchorage has fertile farmland and has produced grain, potatoes and record-sized vegetables despite a short growing season..."
 CQ Press, December 17th 1976

942

“...Another area holding great potential for development is hydroelectric power derived from some of the state’s great rivers...”

CQ Press, December 17th 1976

943



The *Yukon River* is a major north-western *North America* water-course. Over half of the river lies in the *State of Alaska*, with most of the other portion lying in (and giving its name) to Canada’s *Yukon Territory* (a small part of the river, near the source, is located in *British Columbia*). The river is 2,300-miles long and empties into the *Bering Sea* at the *Yukon-Kuskokwim Delta*. The average flow is 227K cubic-feet per second. Total drainage area is 321,500 square miles (of which 126,300 square miles is in Canada). By comparison, the total area is more than 25% larger than the *State of Texas*. Many of Alaska’s interior rivers flow into the Yukon.

Top: caption: “Yukon River, Interior, Alaska”

Bottom: caption: “Aerial of the mighty Yukon River” 944

Last Frontier

945

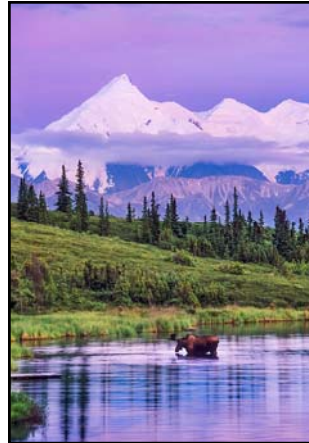

“...But as development inevitably progresses in Alaska, it will become increasingly important to protect many of the state’s natural and scenic areas from harm through human activity. Alaska still is the nation’s last frontier, and the largest remaining wilderness. Its incomparable wildlife - caribou, grizzly bears, bald eagles, moose, walrus, polar bears and many more - must be allowed sufficient habitat to survive and prosper. Alaska’s breathtaking scenery - mountains, forests, glaciers, lakes, and dunes, ice floes, wildflowers - must not be permanently scarred. And the state’s native population of Eskimos, Indians and Aleuts - some of whom still live as their ancestors did centuries ago by subsistence hunting - must be given the chance to determine their own future. These are perhaps the greatest challenges of Alaskan development.” 946

CQ Press, December 17th 1976

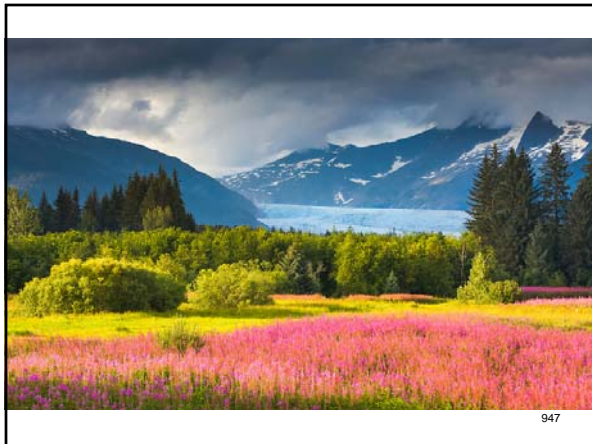

947

Lines Upon the Earth

948

"...If the Great Walls of China are massive works of antiquity that from afar look like a zipper upon the earth, and Australia's Dog Fence is a set of wires threaded through the narratives of a country, then the Trans-Alaska Pipeline looks like an alien artifact worming through the planet. You look straight at it, turn your head left and right to see how far it goes, and it makes very little sense at first. It might as well be a flying saucer; it's just too big, too weird, too resistant to opinion. It does, however, invite wonder...Lines, because they are such a fundamental unit within our perceptual neurology, command allegiance. The pipeline, the Dog Fence, the Walls of China are all fixed in place, at least for a little while, but lines in nature seldom are. They move around, whether they are coastlines, the isotherms of equal temperatures around the world, the front lines of ice in glaciers and permafrost. Yet our anthropic lines have profound effects on those less visible but much larger lines upon the Earth. A human line is always a barrier of some kind to the natural movements of other species, slowing the spread of genes on either side of the Great Walls and the Dog Fence, as well as the migrations of herds. Above and beyond that, the pipeline is abetting the movement of energy through time, from underground to aboveground, and literally fueling climate change, moving the isotherms. A line seems so simple, but make a mark and you reorder the world around it."

Orion Magazine 949

