



PDHonline Course C825 (2 PDH)

An Introduction to Foundation Investigations for Arch Dams

Instructor: J. Paul Guyer, P.E., R.A., Fellow ASCE, Fellow AEI

2020

PDH Online | PDH Center

5272 Meadow Estates Drive
Fairfax, VA 22030-6658
Phone: 703-988-0088
www.PDHonline.com

An Approved Continuing Education Provider

An Introduction to Foundation Investigations for Arch Dams

J. Paul Guyer, P.E., R.A.

1. INTRODUCTION. Foundation investigations for arch dams generally must be accomplished in more exacting detail than for other dam types because of the critical relationship of the dam to its foundation and to its abutments. This chapter will describe the procedures which are commonly followed in accomplishing each phase of these investigations including the foundation analysis. It is very important that these investigations employ the latest state-of-the-art techniques in geological and rock mechanics investigations. This work is usually accomplished in relatively discrete increments or phases with each leading to the succeeding one and building upon the previous one. These phases are described as separate sections in the following text and are covered in chronological order as they are normally accomplished. Usually, a considerable amount of geological information and data are available in the form of published literature, maps, remotely sensed imagery, etc. which should be assembled and studied prior to initiation of field investigations. This information is very useful in forming the basis for a very preliminary appraisal of site adequacy and also serves as the basis for initiation of the succeeding phase of the investigation.

2. SITE SELECTION INVESTIGATIONS. This phase of foundation investigation is performed for the purpose of locating the safest and most economical site(s) on which to construct the arch dam. It also will serve to verify the suitability of the foundation to accommodate an arch dam.

2.1 IT IS IMPORTANT TO DETERMINE the rock types, rock quality, and suitable founding depths for the dam. This information will be required in estimating foundation treatment and excavation depths necessary for the construction of a dam at each of the potential sites being investigated. This information is utilized in the development of cost comparisons between the various sites being evaluated for site selection. Investigational techniques at this stage normally consist of geophysical surveys and limited core borings used together to prepare a subsurface interpretation along the alignment of each site under evaluation. Sufficient data must be obtained to preclude the likelihood of missing major foundation defects which could change the order of comparison of the sites evaluated. The type and spacing of core borings as well as the geophysical surveys must be designed by a competent engineering geologist taking into account the foundation rock types and conditions and anticipated structural configuration of the dam. This must be done in close coordination with the dam designer.

2.2 A MAJOR FACTOR THAT MUST BE considered in site selection is the topography of the site. Sites are classified as narrow-V, wide-V, narrow-U, or wide-U. Another factor to be considered in site selection is the quality of the rock foundation and the depth of excavation required to expose rock suitable for founding the structure. A third factor is the storage capacity of the reservoir provided by each different site investigated. All these factors must be considered in the economic comparison of each site to the others.

3. GEOLOGICAL INVESTIGATIONS OF SELECTED DAM SITE. Very detailed geological investigations must be performed at the selected dam site location to provide a thorough interpretation and analysis of foundation conditions. These investigations must completely define the rock mass characteristics in each abutment and the valley bottom to include accurate mapping of rock types, statistical analysis of rock mass discontinuities (joints, bedding planes, schistosity, etc.), location of faults and shear zones, and zonation of the subsurface according to rock quality as it is controlled by weathering. In addition to these geologic studies, the potential for earthquake effects must be assessed based on a seismological investigation.

3.1 SURFACE INVESTIGATIONS. This stage of investigation frequently entails additional topographic mapping to a more detailed scale than was needed for the site selection investigations. This is followed by detailed geologic mapping of all surface exposures of rock. Frequently it is necessary to increase these exposures by excavating trenches and pits to reveal the rock surface in areas covered by soil and vegetation. The fracture pattern existing in the rock mass is of particular significance and must be carefully mapped and analyzed. Any evidence of faulting and shearing should be investigated. Linear and abnormal configurations of surface drainage features revealed by remote sensing or on topographic maps may be surface reflections of faults or shear zones and should be investigated if they are located in or near the dam foundation. They may also be of seismological concern if there is evidence that they could be active faults. This concern may require fault trenching and age dating of gouge materials as well as establishing the relationship of the soil cover to last fault displacement to evaluate the potential for future activity on the fault. The surface geologic mapping should provide a sound basis for planning the subsurface investigations, which are the next step.

3.2 SUBSURFACE INVESTIGATIONS. The subsurface investigation program must be very thoroughly planned in advance to obtain all of the necessary information from each boring. This is a very expensive portion of the design effort and it can become much more expensive if the initial planning overlooks requirements which necessitate

reborings or retesting of existing borings to obtain data which should have been obtained initially. The following paragraphs address procedures which must be considered in planning the subsurface investigation program for an arch dam.

3.2.1 CORE BORINGS MUST BE OBTAINED in order to provide hard data on foundation conditions. There are numerous decisions which must be made regarding the borings. The boring location plan is perhaps the first. This plan should contemplate a phased approach to the boring program so that future boring locations can be determined based upon data obtained from the earlier phase. The ultimate goal in locating borings is to provide sufficient coverage within the foundation to essentially preclude the possibility of adverse foundation features escaping detection. This can be accomplished by judicious spacing of borings along the dam axis utilizing both vertical and inclined orientations. Refer to Figures 10-1 and 10-2 for examples of an arch dam boring layout. Target depth for borings is another important consideration. Minimum depths should be established during planning with maximum depth left to the discretion of the geologist supervising the drilling as it is accomplished. Core diameter and type of core barrel are important considerations that affect both the cost of the investigation and the quality of the results. It may well be necessary to experiment with different combinations in order to determine the size and type of barrel that is most effective.

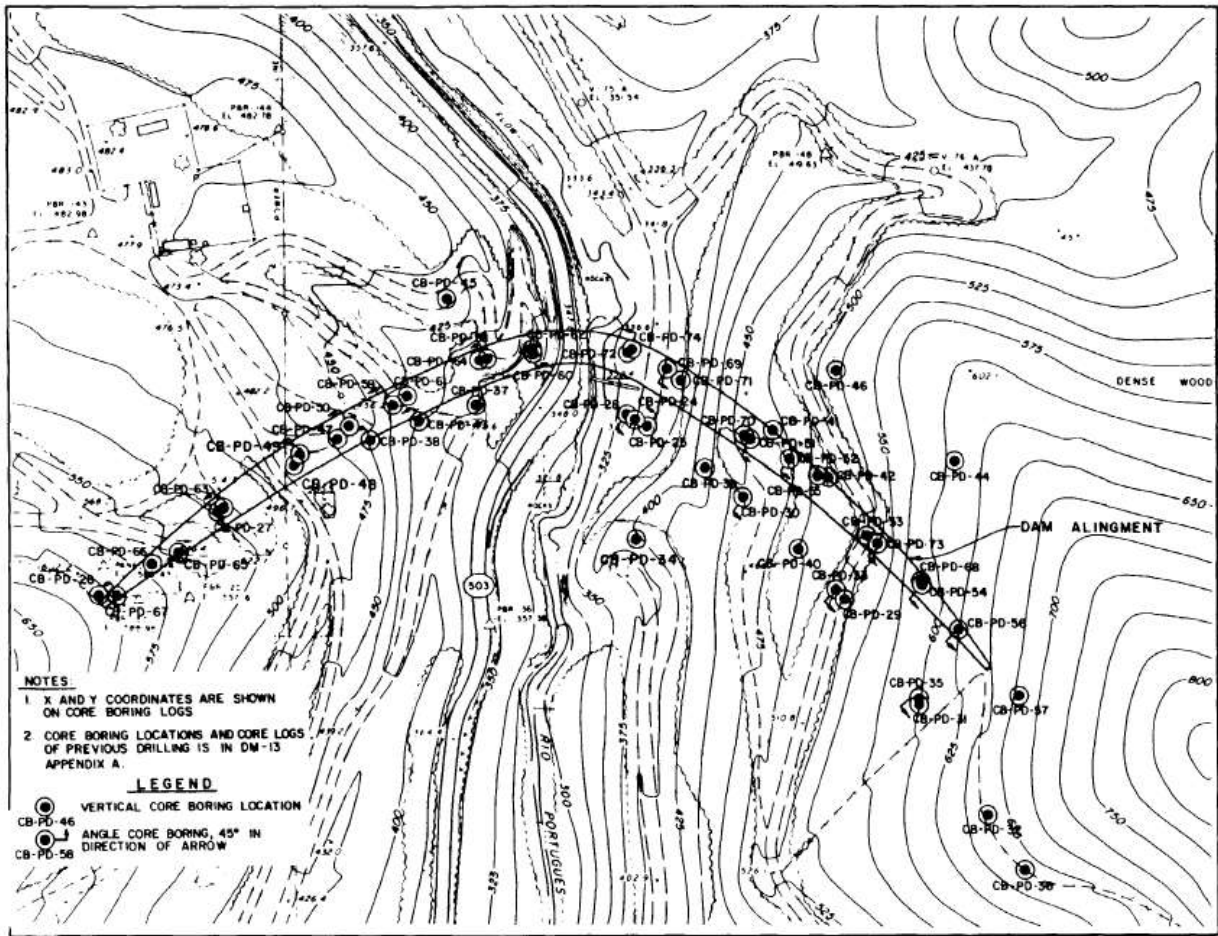

Figure 10-1

Arch dam boring layout plan from Portugues Dam Design

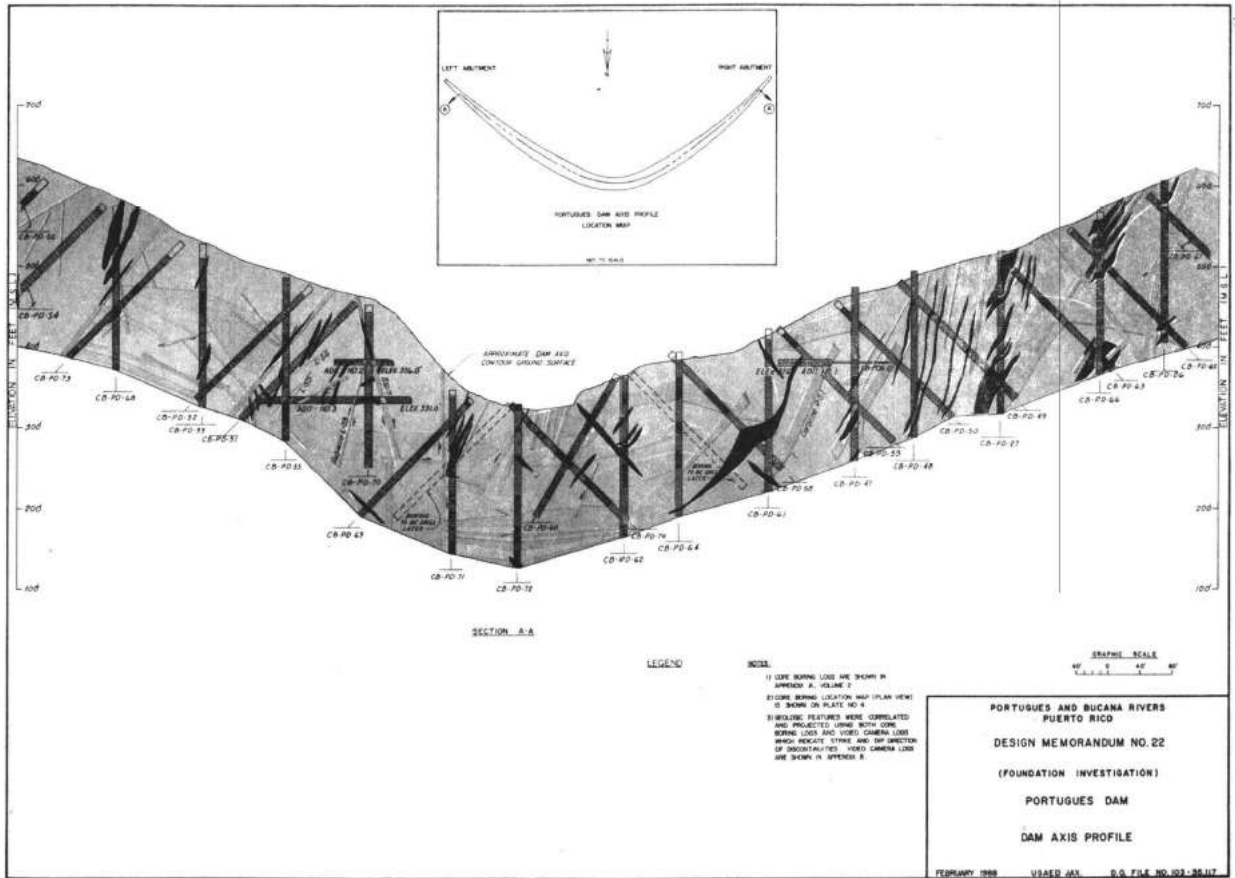

Figure 10-2
Arch dam boring profile from Portugues Dam Design

3.2.2 ROCK CORE LOGGING IS CRITICAL to the subsurface investigation. It is essential that this be performed in considerable detail by a competent geologist, and it is preferable that all rock core logging be done by the same individual, where feasible, for the sake of consistency. The logging should include descriptions of rock type, rock quality including degree of weathering, fractures, faults, shears, rock quality designation (RQD), sufficient data to utilize the selected rock mass rating system, and should be supported with photographs of all of the core taken while still fresh. It is important that the geologist be present during drilling in order to log such occurrences as drill fluid losses, rod drops, changes in drill fluid color, rod chatter, drilling rate, etc. These types of data used in conjunction with the log of the rock core can greatly improve the interpretation of the foundation encountered by a particular boring.

3.2.3 BORE HOLE LOGGING and testing should be utilized to enhance the amount of information obtained from each hole drilled. Certain techniques work better in some environments than in others; thus, the following techniques listed must be utilized discriminately according to their applicability to the site conditions. Bore hole logging systems include caliper logs, resistivity logs, SP logs, sonic logs, radioactive logs, etc. Bore hole TV cameras also provide important information on foundation conditions such as frequency and orientation of fractures and condition of rock in intervals of lost core. Bore hole pressure meters such as the Goodman Jack may provide valuable information on the rock mass deformation properties. Water pressure testing is important to develop data on the potential seepage characteristics of the dam foundation. All these techniques should be considered when planning the subsurface investigations. It is generally more efficient to perform these investigations at the time the hole is being drilled than to return to the hole at a later date.

3.2.4 LABORATORY TESTING OF CORE SAMPLES is necessary to provide design data on foundation conditions. Petrographic analysis is required to correctly identify the rock types involved. It is necessary to obtain shear strength parameters for each different rock type in order to analyze the stability of the foundation. The shear tests are normally run in a direct shear box and are performed on intact samples, sawed samples, and along preexisting fracture planes. This provides upper- and lower-bound parameters as well as parameters existing on natural fractures in the rock. The geologist and design engineer can then use these data to better evaluate and select appropriate shear and friction parameters for use in the foundation stability analysis. Another test performed on core samples is the unconfined compression test with modulus of elasticity determination. This provides an index of rock quality and gives upper-bound values of the deformation modulus of the rock for later comparison and correlation with in situ rock mass deformation tests.

3.2.5 GEOPHYSICAL SURVEYING TECHNIQUES can be utilized to improve the geological interpretation of the foundation conditions. These should be used in

conjunction with the surface geological mapping and with the core borings to provide an integrated interpretation of subsurface conditions. Surface resistivity and refraction seismology are techniques which may provide usable data on depth of overburden and rock quality variations with depth as well as stratification. Cross-hole seismic surveys are sometimes successful in detecting large fault zones or shear zones trending between borings. Other geophysical techniques such as ground penetrating radar and electrical spontaneous potential are available, are being further refined and improved, and should be considered for environments where they have a likelihood of success. Seismic techniques are also appropriate for determining the dynamic modulus of deformation of the rock mass.

3.2.6 GROUND WATER INVESTIGATIONS and permeability testing are necessary for several reasons. These investigations provide the basis for design of any dewatering systems required during construction. They also provide the data to evaluate the reservoir's capability to impound water and to design seepage and uplift control required in the foundation beneath the dam and in the abutments. These data also provide the basis for making assumptions of uplift on rock wedges. Ground water levels, or their absence, should be carefully and accurately determined in all borings. Water pressure testing should be accomplished in most foundation and abutment borings to locate potential seepage zones and to provide data to help in designing the foundation grouting program. The literature is extensive concerning procedures for performing and evaluating bore hole pressure tests. Pumping tests are also very important in providing data for evaluation of the foundation seepage characteristics of the foundation. Reference is made to EM 1110-1-1804 for further guidance on both pressure testing and pump testing.

3.2.7 GROUT TESTING IS NECESSARY for multiple reasons. First, it is necessary to evaluate the groutability of the foundation. Water pressure testing alone can be very misleading in evaluating groutability because rock with very fine fractures may take significant quantities of water but be impervious to even a very thin cement grout. Grout testing is also required for determining the optimal size grout hole and the most

effective means of drilling the hole. In some rock foundations, percussion drills with cuttings removed by air provide the best holes for grout injection, while in others, rotary drills utilizing water for cuttings removal are the most appropriate. A grout test provides the opportunity to experiment with multiple drilling techniques and various hole diameters to determine the most effective ones prior to entering into the main construction contract when changes are normally quite expensive. Another important reason for grout testing is to improve the estimates of quantity of grout take and length of holes likely to be required in the main contract. Perhaps the most important reason to perform a grout test is to provide an evaluation of the probable effectiveness of the grout curtain for consideration during design.

3.2.8 RIM TESTS AND EVALUATIONS are important in some reservoir areas where there may be concerns for excessive loss of water through rim leakage or where potentially large landslides may occur which could displace a significant volume of the lake causing over topping of the dam. These evaluations can be accomplished through topographic and geologic mapping of the reservoir rim followed by core boring, water table determination, and pressure testing in those areas of concern. Remedial measures may be required in areas which are susceptible either to excessive leakage or to significant landslides.

3.3 ABUTMENT ADITS. Adits provide excellent access for in situ observation and mapping of foundation conditions as well as large-scale rock mass testing. Information obtained from adit investigations provides a much higher level of confidence that all significant foundation defects have been detected than if borings and geophysical surveys alone are used. They also greatly improve the confidence level in the mapping and statistical evaluation of the rock mass fracture system. It is advisable to include adits in the subsurface investigation program for arch dam sites with difficult or unusual foundation conditions.

3.3.1 EXPLORATORY ADITS MAY BE of various sizes and shapes, however, 5 feet wide by 7 feet high is considered to be about the minimum size. A more practical size

is 7 feet wide by 8 feet high in that it provides adequate space for the contractor's excavating equipment and for in situ rock mechanics testing. The horseshoe shape is a good configuration for an exploratory adit. It provides essentially vertical side surfaces and a horizontal floor surface which are more easily surveyed and mapped than curved configurations. The adit locations in the abutments should be selected with two factors in mind. First, it is desirable to locate them so that the in situ rock mechanics tests can be performed at or near the location of the maximum stress to be applied to the foundation by the dam. This is normally at about the one-third height of the dam. Another factor to be considered in the location is the geology of the abutments. If there are conditions of concern, such as faults, shear zones, etc., it may be necessary to locate the adits to provide access to these features for in-place inspection and testing. The adits should be oriented to provide maximum intersection of the fracture system and to provide access for in situ testing of the rock mass immediately below the founding level of the dam. It is prudent to construct an adit in each abutment if foundation conditions vary significantly from one abutment to the other. Geological conditions may require more than one adit in an abutment.

3.3.2 GEOLOGIC MAPPING IS REQUIRED FOR EACH ADIT. The preferred procedure to follow is the full periphery method. The results can be displayed in reports in both plan and isometric views. Refer to Figures 10-3 and 10-4 for examples.

3.2.3 SURVEYS OF JOINTS AND OTHER rock mass discontinuities should be accomplished while performing the adit mapping. The adits provide excellent exposures for obtaining data for a statistical analysis of the fracture system in the rock. It is important to perform bias checks to assure that the orientation of the adit is not resulting in over counting of some joint sets in relation to others. For instance, a joint set oriented perpendicular to the axis of the adit will be intersected much more frequently than one oriented parallel, thereby tending to bias the statistical analysis. It is also important to describe the spacing, frequency, extent or degree of separation, openness, roughness, joint filler, and wall rock condition of weathering of each fracture set across the width and height of the adit. This information is needed when

determining shear strength parameters for individual fracture sets for use in stability analysis. Stereographic projection coupled with statistical analysis is an excellent method for determining the preferred orientation of the joint sets.

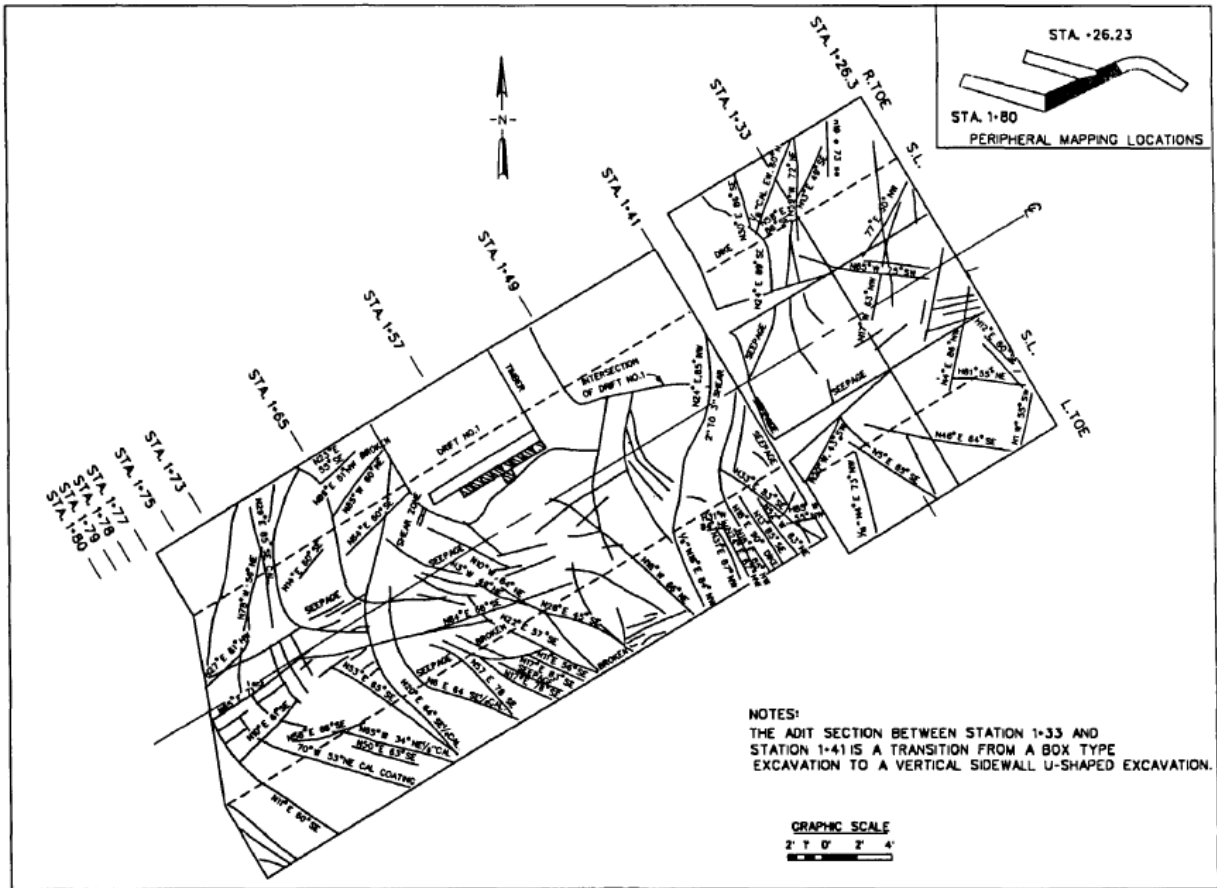

Figure 10-3
Adit periphery mapping plan view from Portugues Dam Design

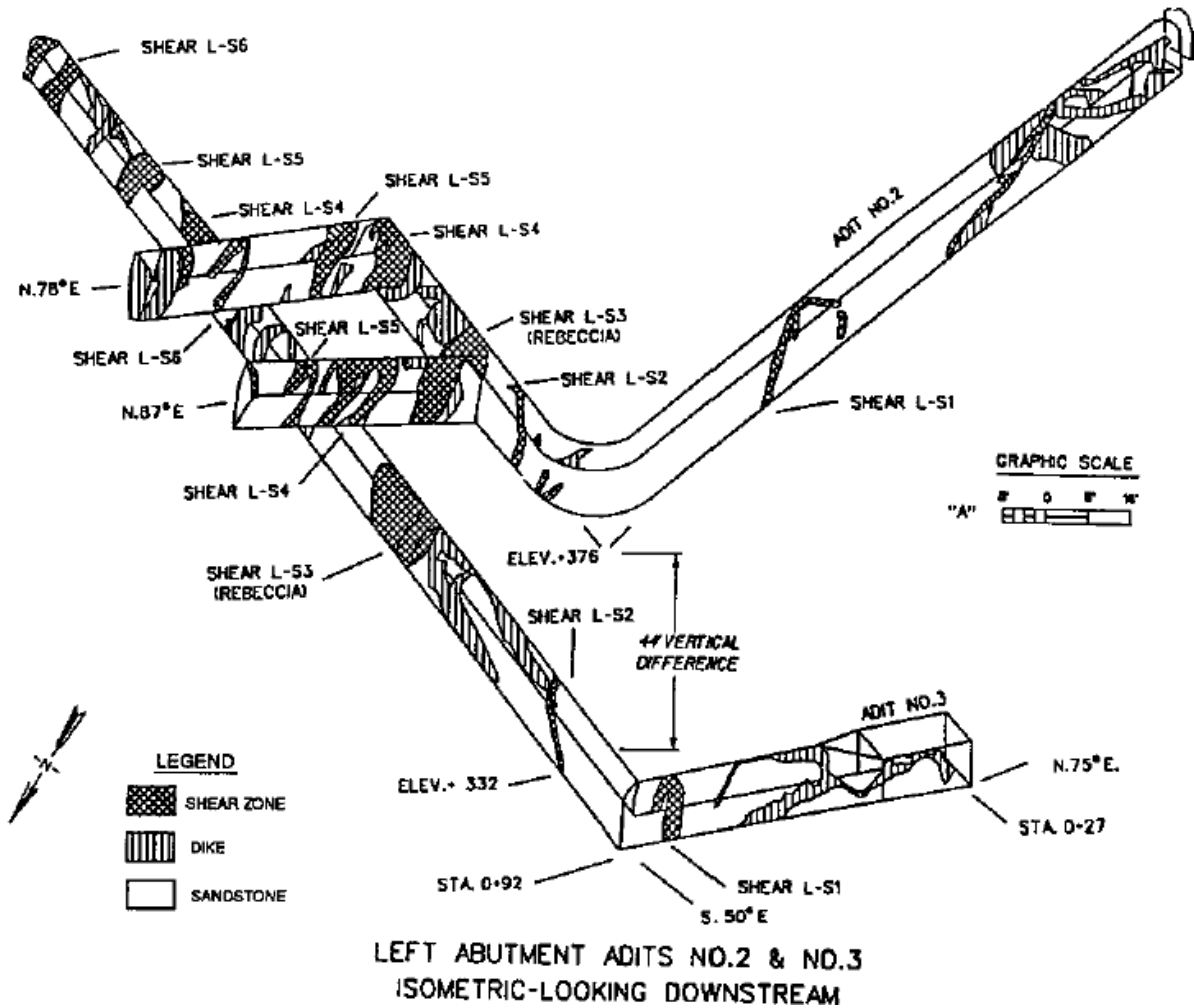

Figure 10-4

Adit periphery mapping isometric view from Portuges Dam

3.2.4 ADITS PROVIDE AN OPPORTUNITY to obtain samples for laboratory testing as well as providing access for in situ testing. Shear zones and faults with their gouge and brecciated intervals may be sampled for laboratory testing. The tests may include mineral identification, shear strength determination, Atterberg limits of soil-like materials, etc. In situ testing may include uniaxial jacking tests to determine the rock mass deformation properties, shear testing of discontinuities, and measurement of in situ rock stress.

3.3 TEST EXCAVATIONS. Test excavations are valuable aids in a dam site investigation.

3.3.1 TEST PITS AND TRENCHES can provide the field geologist with strategically located exposures of the bedrock for mapping purposes. A bulldozer is usually necessary to prepare access roads to core drill locations. Excavation for abutment access roads can provide very good exposures of the rock surface. These roads can be extended as necessary to provide the field geologist with exposures where they are needed. Normally, it is wise to expose the bedrock for mapping in trenches or road cuts that zig zag across the dam site from valley bottom to the top of dam on each abutment. This additional exposure of the rock will normally significantly improve the geologic interpretation of foundation conditions.

3.3.2 LARGE DIAMETER CALYX BORINGS may in some instances be required where individual foundation features are of such concern that it is necessary for the field geologist to examine them in place. They are very expensive but are less costly than excavating an adit.

3.3.3 THE DAM FOUNDATION IN THE VALLEY BOTTOM and on the abutments may be excavated by separate contract prior to the main dam contract as a means of fully exposing the foundation for examination by the geologists and the dam designers. At this point in time, changes in the dam's design can still be made without incurring excessive delay costs from the main dam contractor. The foundation should be carefully mapped and the geologic interpretation formalized as a part of the foundation design memorandum. It should also be incorporated into the final foundation report. Final foundation preparation and cleanup, including some additional excavation, should be left for the main dam contract because most rock surfaces will loosen and weather when left exposed to the elements for a significant period of time.

3.4 ROCK MASS RATING SYSTEM. An important consideration in the geological investigations of an arch dam foundation is to obtain sufficient data to allow the quality of the foundation to be quantitatively compared from one area to another. In order to do this, it is necessary to adopt a rock mass rating system for use throughout the geological investigations. Several such systems have been developed. Bieniawski (1990) provides a survey of the more widely accepted systems. These systems were for the most part developed to provide a means of evaluating rock mass quality for tunneling; however, they can be adapted to provide a meaningful comparison of rock quality in a foundation. The geomechanics classification proposed by Bieniawski (1973) is particularly useful. This system assigns numerical values to six different rock parameters which can be obtained in the field and from core borings. The rock mass rating (RMR) is calculated as follows:

$$R = A + B + C + D + E - F \quad (10-1)$$

where

- A = Compressive strength of intact rock
- B = Deere's RQD
- C = Spacing of joints
- D = Condition of joints
- E = Ground water conditions
- F = Adjustment for adverse joint orientation

Factor F is very important in assessing rock quality in a tunnel but is not necessarily appropriate in a classification system for assessing the rock mass strength of an arch dam foundation, since it is taken into account in the foundation stability analysis. For this reason it may be advisable to consider altering the system for individual arch dam foundation evaluations. Table 10-1 from Bieniawski (1990) provides the geomechanics classification of jointed rock masses. It is important when logging rock core or when performing geologic mapping to assure that all data necessary for the rock mass rating system are collected.

3.5 STERIONET ANALYSIS OF ROCK FRACTURE SYSTEM. An analysis must be made of the fracture system in each abutment and the valley section for use in the rock mechanics analysis of foundation and abutment stability. The Schmidt equal area stereonet utilizing the lower hemisphere projection is the conventional system normally used. Individual fractures (joints) are located on the stereonet by plotting the point on the lower hemisphere where a pole constructed normal to the plane of the fracture would pierce the hemisphere. After all fractures being analyzed are plotted on the stereonet, an equal area counting procedure is used to determine the percentage of poles which fall in each area. These are then contoured similar to the contouring procedure for a topographic map. The contoured stereonet can then be readily evaluated to determine the orientation of the primary, secondary, tertiary, etc. joint sets. Refer to Figure 10-5 for an example of an equal area joint polar diagram.

4. ROCK MECHANICS INVESTIGATIONS. The foundation of an arch dam must function as an integral part of the structure. It is very important that the dam designer fully appreciate and understand the mechanical properties of the foundation. To fully describe the foundation conditions so that they may be quantified for incorporation in the dam design, it is first necessary to accurately and completely define the geologic conditions as described previously, and then define the rock mass mechanical properties. A thorough rock mechanics investigation of the geologic environment of the foundation is necessary to provide the quantification of foundation properties necessary for the dam foundation analysis. It is extremely important that the engineering geologist, geotechnical engineer, and the structural designer work closely and cooperatively during the rock mechanics investigation and foundation analysis to assure that the concerns of each are adequately addressed. Each has a unique perspective on the design which can contribute to the success of the rock mechanics investigation and foundation analysis.

A. CLASSIFICATION PARAMETERS AND THEIR RATINGS

PARAMETER		RANGES OF VALUES							
1	Strength of intact rock material	Point-load strength index	> 10 MPa	4 - 10 MPa	2 - 4 MPa	1 - 2 MPa	For this low range - uniaxial compressive test is preferred		
		Uniaxial compressive strength	>250 MPa	100 - 250 MPa	50 - 100 MPa	25 - 50 MPa	5-25 MPa	1-5 MPa	<1 MPa
	Rating		15	12	7	4	2	1	0
2	Drill core quality RQD		90% - 100%	75% - 90%	50% - 75%	25% - 50%	< 25%		
	Rating		20	17	13	8	3		
3	Spacing of discontinuities		>2m	0.5 - 2 m	200 - 600 mm	60 - 200 mm	< 60 mm		
	Rating		20	15	10	8	5		
4	Condition of discontinuities		Very rough surfaces. Not continuous. No separation. Unweathered wall rock.	Slightly rough surfaces. Separation < 1 mm. Slightly weathered walls	Slightly rough surfaces. Separation < 1 mm. Highly weathered walls	Stickered surfaces OR Gouge < 5 mm thick OR Separation 1-5 mm. Continuous	Soft gouge > 5 mm thick OR Separation > 5 mm. Continuous		
	Rating		30	25	20	10	0		
5	Ground water	Inflow per 10 m tunnel length	None	<10 litres/min	10-25 litres/min	25 - 125 litres/min	> 125		
		Ratio $\frac{\text{joint water pressure}}{\text{major principal stress}}$	OR 0	OR 0.0-0.1	OR 0.1-0.2	OR 0.2-0.5	OR > 0.5		
		General conditions	OR Completely dry	OR Damp	OR Wet	OR Dripping	OR Flowing		
	Rating		15	10	7	4	0		

B. RATING ADJUSTMENT FOR JOINT ORIENTATIONS

Strike and dip orientations of joints		Very favourable	Favourable	Fair	Unfavourable	Very unfavourable
Ratings	Tunnels	0	-2	-5	-10	-12
	Foundations	0	-2	-7	-15	-25
	Slopes	0	-5	-25	-50	-60

C. ROCK MASS CLASSES DETERMINED FROM TOTAL RATINGS

Rating	100-81	80-61	60-41	40-21	< 20
Class No	I	II	III	IV	V
Description	Very good rock	Good rock	Fair rock	Poor rock	Very poor rock

D. MEANING OF ROCK MASS CLASSES

Class No	I	II	III	IV	V
Average stand-up time	10 years for 15 m span	6 months for 8 m span	1 week for 5 m span	10 hours for 2.5 m span	30 minutes for 1 m span
Cohesion of the rock mass	> 400 kPa	300 - 400 kPa	200 - 300 kPa	100 - 200 kPa	< 100 kPa
Friction angle of the rock mass	> 45°	35° - 45°	25° - 35°	15° - 25°	< 15°

TABLE 10-1

Geomechanics Classification of Jointed Rock Masses.

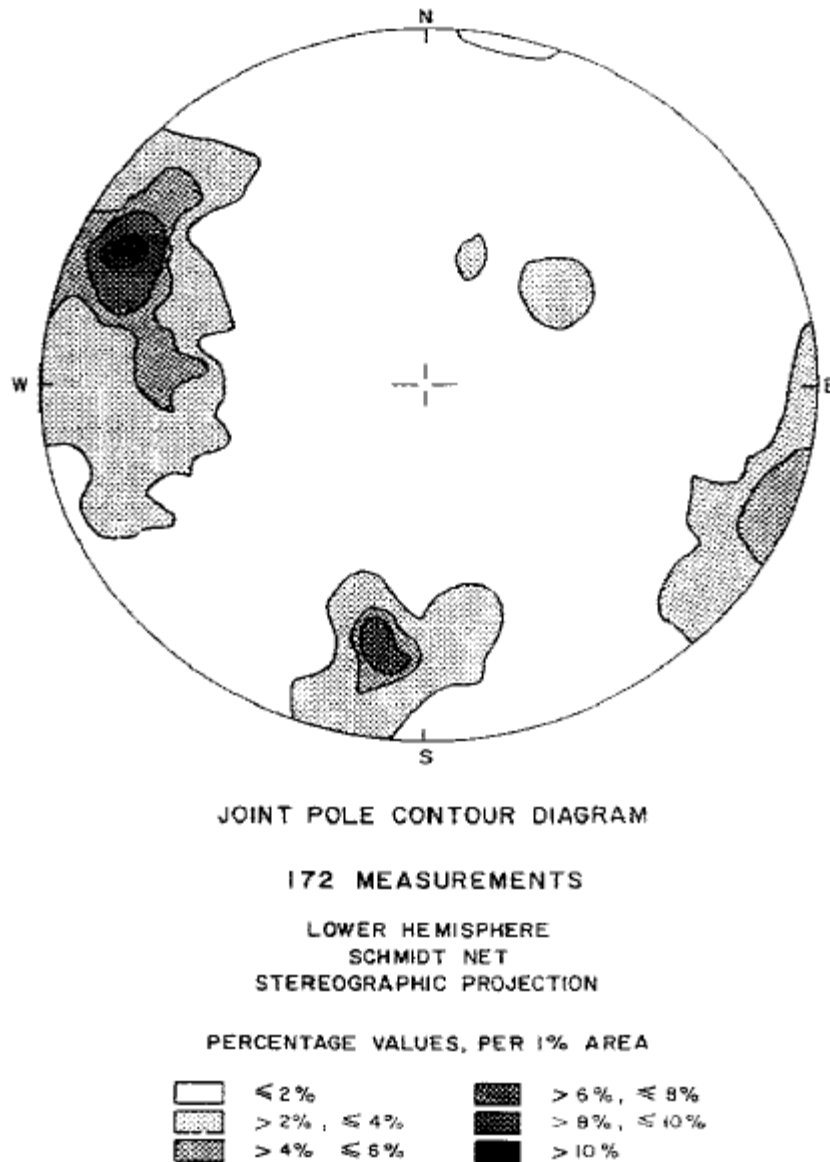

Figure 10-5

Equal area joint pole contour diagram from Portugues Dam Design

4.1 LABORATORY TESTING OF SAMPLES. Laboratory testing is much less expensive than in situ testing and can provide very good data. The laboratory testing must be evaluated and the design assumptions made by a competent and experienced geotechnical engineer in full coordination with an engineering geologist who fully appreciates the geologic conditions in the foundation which could adversely affect the performance of the dam. The laboratory testing should incorporate

unconfined compression tests including determination of modulus of elasticity on a suite of samples from each rock type and each rock quality to be found below the founding level of the dam. These tests will provide an index of rock strength and will provide data on the upper bound deformation modulus of the rock. Direct shear testing should be performed on a suite of samples from each rock type and rock quality to provide data for use in determining shear strength values to be used in foundation analyses. This type of test should be performed under three separate conditions: on intact samples to provide an upper-bound set of data on shear strength parameters, on sawed surfaces to provide a lower-bound or residual strength set of data, and finally, on natural fractures to provide data on the shear friction parameters resisting sliding on these features. In those cases where clay or silt material exists as gouge in fault zones, in shear zones, or as in-filling in open joints, it is advisable to obtain samples of this material and perform shear tests on preferably undisturbed samples or on remolded samples where undisturbed samples are not feasible. Both triaxial and direct shear tests are appropriate for these samples. When interpreted conservatively and with a full appreciation of the geologic conditions, test data obtained as described will usually provide a sound basis for estimating the shear strength parameters for use in the foundation stability analyses.

4.2 ABUTMENT ADITS. Adits are excavated in the abutments for two primary purposes. First, they are constructed to provide access to map geologic conditions and to expose geologic features of structural concern. Of equal importance is the access provided to perform in situ rock mechanics testing of foundation conditions.

4.2.1 IN SITU DEFORMATION TESTING IS PERFORMED in the adits as a means of determining the stiffness of the foundation. From these tests the static modulus of deformation of the foundation can be calculated at that particular location. Several different techniques have been developed for performing deformation testing. These include the uniaxial jacking test, the radial jacking test, and the pressure chamber jacking test. The uniaxial jacking test is the one most commonly used primarily because it is less costly and easier to set up while still providing satisfactory results.

Figure 10-6 is a diagram of a typical uniaxial jacking test setup. It consists of the following: a load frame which transfers load from one wall of the adit to the other, two flat jacks which apply the loads to the rock surfaces, two multiposition borehole extensometers which measure the deflection or deformation of

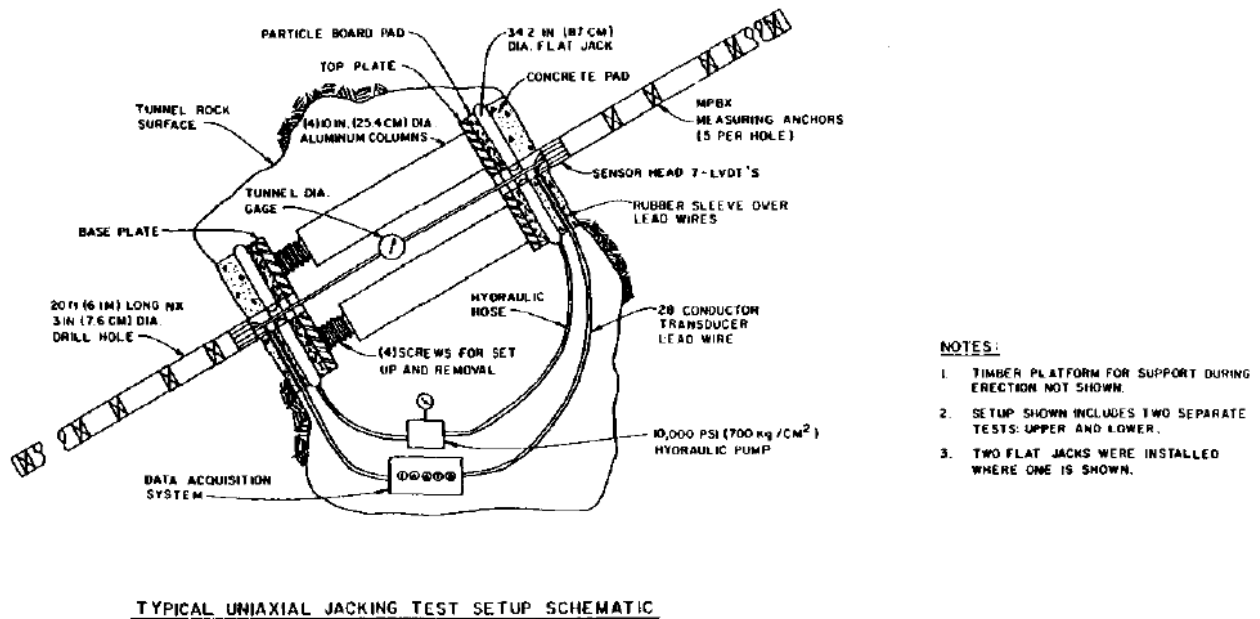

Figure 10-6
Uniaxial jacking test diagram from Portuges Dam

the rock mass as it is loaded or unloaded, a tunnel diameter gauge which measures changes in tunnel dimensions as load is applied or released, and a very high-pressure hydraulic jack. The axial orientation of the test is selected to coincide with the resultant of the forces applied to the foundation by the dam. The test as depicted in Figure 10-6 provides a measure of the rock mass deformation on two opposing surfaces of the adit. This in effect provides two rock mass modulus of deformation tests at this location. The test is performed by loading the rock in predetermined increments for a specific period of time. Incremental increases of 200 psi held for periods of 24 hours with complete unload between each pressure increase is commonly used. The unloaded increment of time is also commonly 24 hours. The maximum load applied should exceed the maximum pressure to be applied by the dam. A maximum test pressure of 1,000 psi is commonly used. Deformation measurements should be made

at frequent intervals during both loading and unloading cycles. These measurements can provide data for evaluating the creep potential and initial set after loading in the rock mass in addition to the modulus of deformation. The following publication of the American Society for Testing and Materials (ASTM) provide detailed test and analytical procedures for computing the rock mass modulus of deformation D4395-84 (ASTM 1984b). The following equations taken from these references may be used for computing the modulus of deformation:

Flexible loading system

(Surface deflection at center of circularly loaded area)

$$E = \frac{2(1-\mu^2)QR}{W_c} \quad (10-2)$$

(Surface deflection at center of annularly loaded area)

$$E = \frac{2Q(1-\mu^2)(R_2-R_1)}{W_c} \quad (10-3)$$

Rigid loading system

(surface deflection)

$$E = \frac{(1-\mu^2)(P_1)}{2W_a R} \quad (10-4)$$

where

- E = modulus of deformation
- μ = Poisson's ratio
- Q = pressure
- R = radius of loaded area or radius of rigid plate
- W_c = deflection at center of loaded area

- R_2 = outside radius of annulus
- R_1 = inside radius of annulus
- W_a = average deflection of the rigid plate
- P = total load on the rigid plate

The ASTM references contain other equations for calculating the modulus of deformation for deflections measured within the rock mass.

4.2.2 PROCEDURES ARE AVAILABLE FOR DETERMINING the elastic properties of rock utilizing seismic techniques. These are described in some detail in ASTM publication STP402 (ASTM 1965a). This technique provides a Poisson's ratio and the dynamic modulus of deformation of the rock mass. Use of the technique for arch dam foundation evaluation must be tempered with considerable practical knowledge and judgement, because the dynamic modulus of deformation so determined is usually significantly higher than the static modulus determined by the uniaxial or radial jacking tests. The open fractures in the rock mass are a major factor in this discrepancy. The rock mass behaves more in the static mode than the dynamic mode under loading from a dam, therefore, the static modulus is more appropriate for analyzing the foundation for an arch dam, except in evaluating dynamic earthquake response.

4.2.3 IN SITU SHEAR TESTING CAN BE PERFORMED in an adit to test the shearing resistance of an individual feature in the foundation if conditions demand this information. The test, however, is very expensive and provides information only on the feature tested. In many cases it is more practical to perform extensive laboratory tests of shear strength and to use this information along with engineering experience as the basis for arriving at the proper shear strength parameters for use in the foundation stability analyses.

4.2.4 IN THOSE CASES WHERE ABNORMALLY high in situ stress may exist in the foundation or abutment rock mass, it may be advisable to perform in situ testing to measure the in-place stress regime for consideration during the foundation analysis. Several instruments have been developed for measuring the strain release in an over cored bore hole. These instruments are suitable for determining the in situ stress existing within about 25 feet of a free face or surface from which a boring can be drilled. Flat jacks may be used for measuring stress existing immediately beneath a free face or surface. Bore hole hydraulic fracturing techniques are appropriate for measuring in situ stress at locations remote from a drilling surface. This procedure can measure in-place stress hundreds of feet from the surface. One clue to the existence

of a high in situ stress field is the appearance of diskings in rock core samples. This diskings is caused by stress release in the core occurring after it is freed from the restraint of the surrounding rock by the coring action. Numerous publications available in the literature describe the various in situ stress determination techniques. ASTM publication STP402 (ASTM 1965a) describes various instruments and techniques.

4.2.5 SAMPLING AND LABORATORY TESTING have been discussed previously. In addition to samples obtained from core borings, the adits are also good locations for obtaining samples for laboratory testing. This is particularly true of samples of hard-to-retrieve materials such as fault breccia and fault gouge. These materials must be sampled very carefully to minimize disturbance, and immediately after exposure to retain near natural moisture content. Where possible, planning and preparation for this sampling should be done prior to adit excavation to enhance the likelihood of obtaining usable samples.

5. ROCK MECHANICS ANALYSES. The dam foundation, and in particular its abutments, must be carefully analyzed to evaluate resistance to shear failure, deformation characteristics, and permeability. The foundation must respond as an integral part of the dam and must be fully considered in the design of the dam. Of particular importance is the analysis of the fracture system within the rock mass, including the joints, faults, shears, bedding, schistosity, and foliation. These features must be considered in relation to each other because intersecting fractures can sometimes form potential failure wedges which are more susceptible to sliding than either fracture alone. Since the elastic properties of the dam and its foundation are significant factors in the performance of the dam, it is necessary to estimate the deformation properties of the foundation and abutments within a reasonable degree of accuracy. The permeability of the foundation and uplift pressures on potential failure wedges must be evaluated and incorporated into the design. The engineering geologist, geotechnical engineer, and structural engineer responsible for the dam design must work in full coordination and cooperation in the performance of these analyses to assure that the concerns and objectives of each discipline are satisfied to the maximum extent possible.

5.1 ROCK MASS PROPERTY DETERMINATION. Methods of testing the rock mass to define its physical properties have previously been discussed. These discussions are continued here and include the processes necessary to arrive at values to be used in the foundation and abutment analyses.

5.1.1 IN ORDER TO PERFORM STABILITY analyses of the foundation and the abutments, it is necessary to select appropriate values of the shear strength of each fracture set, shear, fault, or other discontinuity which could form a side of a kinematically capable failure wedge. Laboratory shear tests normally will provide the basic data required for selecting these shear strength values. As stated previously, direct shear testing should be performed on a suite of samples from each rock type and rock quality. This test should be performed under three separate conditions to provide upper- and lower-bound rock strength and shear friction as described.

5.1.1.1 THE DATA PROVIDED BY THIS SERIES of tests should provide part of the basis for determining reliable shear friction values resisting movement on discontinuities. There are other factors which must also be considered in arriving at acceptable shear strength values on a discontinuity. Roughness measures such as the angle of the asperities have a significant effect upon the shear strength of a joint because, for movement to take place, the rock mass must either dilate by riding up and over the asperities or it must shear through them. Either mechanism takes considerable additional energy. The condition (degree of weathering) of the wall rock is another factor to be considered as is the continuity or extent of the open joints which can significantly affect shear resistance to movement. Fracture filling material, such as clay or silt, can dramatically reduce the shear friction strength of a fracture and must be considered.

5.1.1.2 A CONSERVATIVE EVALUATION OF SHEAR strength for rock-to-rock contact on a fracture under relatively low normal load is provided by the following equation:

$$S = N \tan(\phi_r + i) \tag{10-5}$$

where

- S = shear strength of fracture
- N = normal stress on fracture
- ϕ_r = residual friction angle
- i = asperity angle

In this equation, the value of cohesion is omitted under the assumption that failure occurring under a low normal stress would likely result in the wedge overriding the asperities rather than shearing through them. The residual friction angle is derived from the direct shear test on sawed surfaces and should be taken at about the lower one-third point of the range of test values. The asperity angle is developed from actual

measurements of the roughness on typical joints in the foundation. It is important to measure the asperity angle in the same direction that movement would likely occur since the degree of roughness varies considerably from one orientation to another. The angles are measured from a string line oriented in the likely direction of movement. (Refer to Figure 10-8 for an example of a field measurement setup.) Rock shear test results obtained from sawed surfaces are more consistent and amenable to interpretation than those obtained from shearing of intact rock or those obtained from shear testing along natural fractures. A more reliable shear strength value is thus developed by adding the angle of the asperities to the residual shear friction angle in this equation.

5.1.1.3 THE SELECTED SHEAR STRENGTH values for a particular joint may require modification depending upon the other factors noted previously which affect shear strength such as continuity or extent of the fracture, condition of its wall rock, and in-filling material, if any. If fracture continuity is less than 100 percent, then added strength can be allowed for shear through intact rock. The test data obtained from samples sheared through intact rock provide a basis for assigning shear strength values to the portion of the failure plane which is not part of the natural fracture. If the wall rock is weakened by weathering, the strength must be reduced. The suite of tests performed on weathered rock will provide data on which to base this reduction in shear strength. If soft in-filling material is present, rock-to-rock contact is diminished, and the strength must be reduced as a compensation.

5.1.1.4 WHERE GOUGE MATERIAL EXISTS along shears or faults or where joint filling is present, it is necessary to obtain samples of this material for testing. This can best be done from an adit because it is often impossible to obtain an adequate quantity for testing from a bore hole. Undisturbed samples are preferred, but often they are not feasible to obtain. Remolded samples tested at in situ density and moisture content will normally provide satisfactory results. The strength properties of the gouge or in-filling material can be tested utilizing conventional soil property tests.

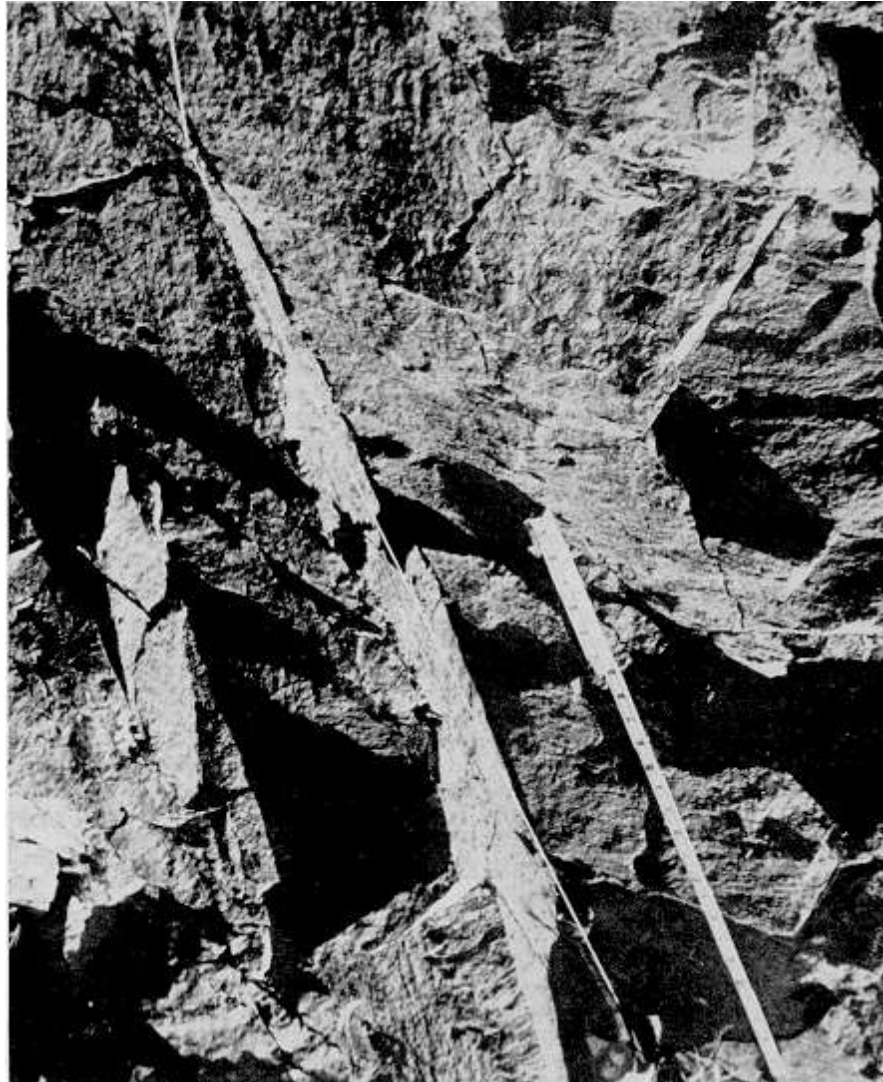

Figure 10-8

Picture of asperity angle "i" measured in the field utilizing a string line for orientation from Portugues Dam

The consolidated, undrained triaxial test is appropriate for testing this material. In the stability analysis, an estimate must be made of the percentage of the potential failure surface which could pass through these soil-like materials. The strength of that portion of the potential failure surface must be assessed based on the tests of the gouge or infilling material.

5.1.2 THE DEFORMABILITY OR STIFFNESS OF an arch dam foundation must be estimated for incorporation in the stress analysis of the dam. The modulus of deformation of the rock mass is a measure of the foundation's deformation characteristics. The modulus can be expected to vary significantly from the valley bottom to the abutments and from one rock quality or rock type to another. The methods of testing and measuring the modulus of deformation have previously been described. It is necessary to translate the test results from a few specific locations to an interpretation of the deformation characteristics of the entire foundation. In order to do this on a quantitative basis, a rock mass rating system is required which permits quantitative evaluation of the rock mass quality over the entire foundation area. There are several rock mass rating systems currently in use worldwide. The geomechanics classification system developed by Bieniawski (1990) and described previously in paragraph 10-3e has proven very useful for foundation analysis. A relationship has been suggested between the geomechanics classification system RMR and the in situ modulus of deformation of the rock mass. This relationship is expressed in the following equation:

$$E = 10^{\left(\frac{RMR-10}{40}\right)} \quad (10-6)$$

where

E = modulus of deformation measured in gigapascals (GPa)

1 GPa = 145,037.7 psi

This equation was used in the rock mechanics analysis of the Portugues Dam Foundation and was a valid predictive model of the foundation deformation properties of the dam. Once this model is validated for a particular site, it is possible to compare the entire site conditions to the in situ tests of modulus of deformation. This is accomplished by determining the RMR for the segment of rock of concern in each core boring made in the foundation and then comparing these borings with the RMR of the

core borings made for installation of the extensometers at the location of the in situ modulus of deformation tests. This comparison used in concert with the relationship noted then allows the assignment of modulus of deformation values to each major portion of the foundation. These values can then be applied in the finite element analysis of the dam and its foundation.

5.1.3 THE PERMEABILITY OF THE FOUNDATION and abutments must be determined for several reasons. As stated earlier in paragraph 10-3b(6), these data are required to evaluate the reservoir's capability to impound water, to provide a basis for design of construction dewatering systems, to provide a basis for design of uplift relief systems, and to serve as the basis for estimating the amount of uplift that must be considered in the stability analysis. The permeability of the foundation can be estimated based primarily on bore hole pressure test data supported by a limited amount of pump test data. A pertinent equation is as follows:

$$K_e = \frac{Q \ln (R/r)}{2\pi LH} \quad (10-7)$$

where

K_e = equivalent coefficient of permeability
 r = radius of bore hole in feet
 Q = volume of flow rate in cfs
 H = excess pressure head at center of test in feet
 R = radius of influence in feet (0.5L to 1.0L)
 L = length of test section of bore hole
 π = pi

5.1.4 IN CASES WHERE ABNORMAL in situ stress conditions are indicated, it may be necessary to perform tests to measure the in situ stress existing in the rock mass, as discussed in paragraph 10-4b(4). These stresses may be significant in the foundation stability analysis. There are several techniques and variations of these techniques available for measuring in situ stress in rock masses. The overcoring procedure is commonly used to measure stresses within a relatively short distance (± 25 feet) from an exposed surface or free face. The hydraulic fracturing procedure is

used to measure stresses existing at locations remote from an exposed surface or free face.

5.1.5 THE POISSON'S RATIO OF THE ROCK MASS must be estimated for some foundation analyses. A satisfactory method of doing this is to obtain the Poisson's ratio at the same time that the modulus of elasticity is determined while measuring the unconfined compression strength of intact rock core samples from each different rock type and quality in the foundation. Mean values obtained from each rock type and quality will provide values that are satisfactory for this purpose.

5.2 ABUTMENT STABILITY ANALYSIS. Much of the previous narrative was intended to provide data and information necessary to perform the abutment stability analyses. Abutment stability is critical to the overall stability of an arch dam. The following subparagraph describes the analytical procedures, the first of which is the use of the stereonet for slope stability analysis.

5.2.1 THE PROCEDURE FOR PERFORMING A STATISTICAL representation of the rock mass fracture system utilizing the equal area stereonet has been described. This concept has also been adapted for use in the stability analysis of the foundation and abutment. The first step in analyzing the stability of the dam foundation is to locate any fracture, fracture set, or combination of fractures which could form a wedge kinematically capable of failure, either as a result of foundation excavation or under the forces applied to the foundation by the dam. For a wedge to be kinematically capable of failure, the dip of the potential failure plane or the plunge of the intersection of two fracture planes along which sliding could occur must intersect or "daylight" on the rock slope or free face. This must also occur in a location which would accommodate failure under the forces imposed by gravity and/or the dam. This step of the analysis is accomplished by plotting the great circle representation of each fracture or fracture set and the natural or cut slope (free face) on an equatorial equal angle stereonet, as demonstrated in Figure 10-9. If the great circle representation of the free face intersects the great circle of both fracture planes and the plunge of the wedge of rock

is a flatter angle than the dip of the free face, then movement of the wedge is kinematically possible without the necessity for crossbed shear through intact rock. The same test can be applied to sliding on a single plane which strikes subparallel to the free face and dips at an angle flatter than the free face. All major fracture sets and unique fractures such as faults and shears must be analyzed for their kinematic capability of movement. Those with the potential for failure must be further analyzed taking into account shearing resistance on the failure planes and driving forces which contribute to the potential for sliding. Since the fractures within an identified joint set normally have a range of orientations, it is not adequate to consider only the average or median orientation. Orientations near the bounds of the range must also be evaluated since they do exist in the rock mass. This first step of determining those wedges which could kinematically fail will eliminate a great many wedges from the need for further analysis.

5.2.2 AFTER DETERMINING THOSE fractures and fracture combinations which are kinematically capable of allowing a wedge of rock to fail, it is then necessary to determine the geometry of a block which would be significant in the foundation of the dam. One conservative assumption that should be made in many cases is that the joint sets identified by the geological investigations are pervasive in the abutment on which they have been identified. By that it is meant that they can be expected to occur anywhere on the abutment. Next, a daylight point of the line of intersection of two fracture systems is chosen and the surface trace of the fractures is drawn. Once all the corners are located, the areas and volumes can be calculated. From this the volume of rock can be determined and converted into the weight of the wedge. The area of the fracture planes can be computed for use in determining the uplift forces acting on the wedge. The size of the wedge must be large enough to be significant to the stability of the dam; i.e., it should be large enough to cause catastrophic failure of the dam. For a wedge to be significant it must be possible for it to exist beneath the dam or immediately adjacent to the dam. Combinations of fractures which result in wedges that are above the top of the dam or outside the foundation of the dam need not be

considered unless excavation will in some way make them a hazard to safety. A third fracture or

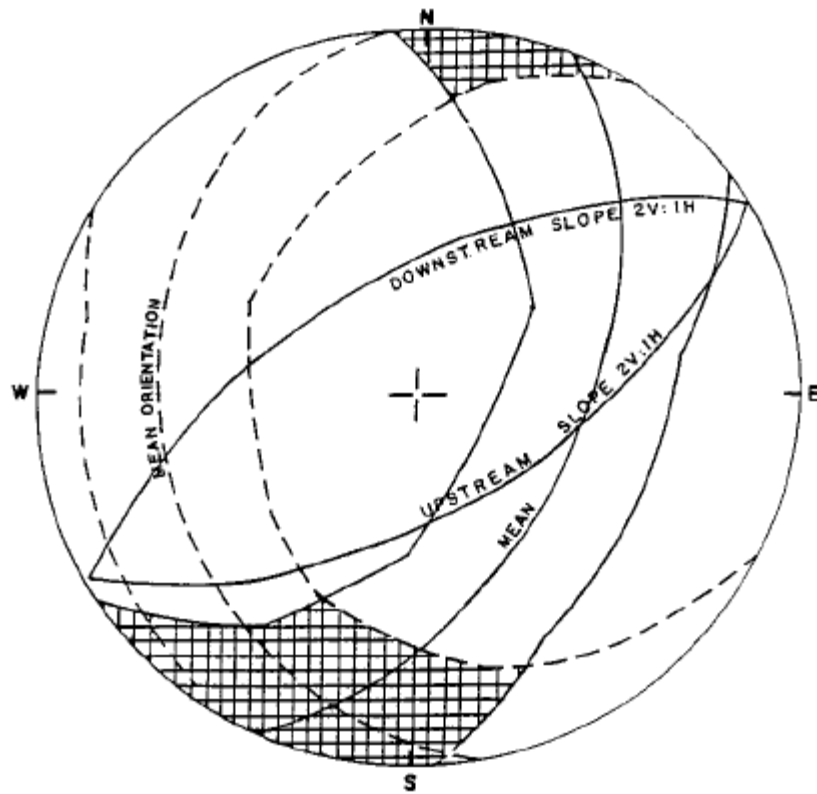

RIGHT ABUTMENT
KINEMATIC TEST
J1 & J3

LEGEND

- J-1
- J-3
-  AREAS OF POSSIBLE INTERSECTIONS OF J1 AND J3 WHERE PLUNGE OF LINE OF INTERSECTION IS LESS THAN SLOPE DIP.

Figure 10-9

An equatorial angle stereonet plot showing two intersecting joint sets and two cut slopes demonstrating kinematic capability for failure from Portugues Dam

fracture set is required in most wedge geometries to cut the back of the wedge free. If no such fracture exists, it is conservative to assume that a tension fracture does exist in the position where such a feature is needed and no tensile strength exists across this feature. A wedge the size of the entire abutment is considered the most critical and is considered the definitive case for each set of intersecting fractures. Smaller wedges must also be considered but are less likely to result in catastrophic failure of the dam as they become smaller.

5.2.3 THREE DIFFERENT STATIC LOADING combinations must be analyzed. These cases have been described in Chapter 4 as static usual, the static unusual, and the static extreme. In addition, the dynamic loadings from earthquakes must be incorporated for dams in areas where there is earthquake potential. Refer to Chapter 4 for description of each different loading case. The loads which must be included in the analysis of potential rock failure wedges are: weight of the rock wedge; driving force applied by the dam; uplift applied by hydrostatic forces acting against the boundaries of the wedge; and dynamic forces generated by the design earthquake. The weight of the rock wedge is determined by calculating the volume of the wedge times the unit weight of the rock. The forces applied by the dam are obtained from the structural analysis of the dam. The computation of uplift forces is based upon the following assumptions:

5.2.3.1 FRACTURES ARE OPEN OVER 100 percent of the wedge area and are completely hydraulically connected to the surface.

5.2.3.2 HEAD VALUES VARY LINEARLY from maximum value at backplane to zero at daylight point.

5.2.3.3 BACK PLANES OR OTHER PLANES or segments of planes acted on directly by the reservoir receive full hydrostatic force. Dynamic loads attributed to the design earthquake are based upon the design earthquake studies which develop ground motions for both an OBE and the MCE. These studies provide values for the

magnitude, distance, peak acceleration, peak velocity, peak displacement, and duration of the earthquakes.

5.2.3.4 THE FOLLOWING SLIDING FACTORS of safety (FS) should be used for the different loading cases:

- (a) Static usual loads ----- FS = 2.0
- (b) Static unusual loads ----- FS = 1.3
- (c) Static extreme loads ----- FS = 1.1
- (d) Dynamic unusual loads ----- FS = 1.3
- (e) Dynamic extreme loads ----- FS = 1.1

These FSs are based on a comprehensive field investigation and testing program as described previously in this chapter.

5.2.3.5 THE FIRST STEP IN PERFORMING A STABILITY analysis of an abutment is to determine those wedges of significant size which are kinematically capable of moving. This step has already been described in paragraph 10-5b(1). The next step is to determine the FS against sliding of the blocks where movement is kinematically possible. There are three different methods that can be used for performing this analysis. The conventional 2-D procedure can be used for conditions where sliding will occur on a single fracture plane. This is the most simple of the three procedures, however, it is not appropriate for the more complicated wedge type conditions where sliding can occur on two or more planes, on the intersection of two planes, or by lifting off one plane and sliding or rotating on another. For more complicated failure mechanisms one of the following procedures should be employed: graphical slope stability analysis utilizing stereonet or vector analysis, as described in the following paragraphs.

5.2.3.5.1 THE GRAPHICAL SLOPE stability analysis is a continuation of the procedure already described for utilizing an equal angle stereonet to determine those wedges where failure is kinematically possible. This step involves plotting on the stereonet those parameters which are involved with the stability of the block. The first

of these is the reaction which resists failure. This consists of a plot of the friction cone which exists on each plane involved in the wedge. This establishes the stable zone on the stereonet. The friction cone will plot as a circle on the stereonet. There will be a separate friction cone plotted for each fracture involved in the boundary of the wedge. The next step requires the determination of the resultant of the forces that are driving the wedge. These forces may include the weight of the rock wedge, uplift resulting from hydrostatic pressure acting normal to all the planes which define the wedge boundaries, thrust of the dam, and where earthquake loading is of concern those inertial forces which could be imposed by an earthquake. The resultant of these forces is obtained by the graphical summation of the vectors representing each force. If the resultant of these forces falls within the cone of friction, then the wedge is stable. In other words, if the resultant acts at an angle to the normal of the failure plane which is less than the angle of friction, then failure will not occur. The FS against sliding may be determined by dividing the tangent of the friction angle by the tangent of the angle made by the resultant of forces and the normal. examples are illustrated in Figure 10-10.

5.2.3.5.2 THE VECTOR ANALYSIS PROCEDURE REQUIRES that all fractures forming the boundary of the wedge be described vectorially relative to the orientation of the abutment face. Vectors must be developed for the strike, dip, normal, and lines of intersection of the boundary fractures. Applied force vectors must be developed for weight of wedge, uplift on all boundary fractures, thrust of the dam, and inertial force resulting from the design earthquake. All these must be combined to form a resultant relative to the abutment face. From this the mode of failure is determined, i.e., sliding on a single plane, sliding on the intersection of two planes, or lifting all planes. By employing the vector analysis procedures, the stability of the wedge can be calculated and an FS can be determined. Figure 10-10 also illustrates this procedure.

5.2.3.5.3 THE ANALYSIS OF THE STABILITY OF the abutments of an arch dam requires very careful application of both engineering geology and rock mechanics investigative and analytical techniques. When these procedures are properly applied

and their results accounted for in the design, a high degree of confidence in the stability of the dam foundation is justified.

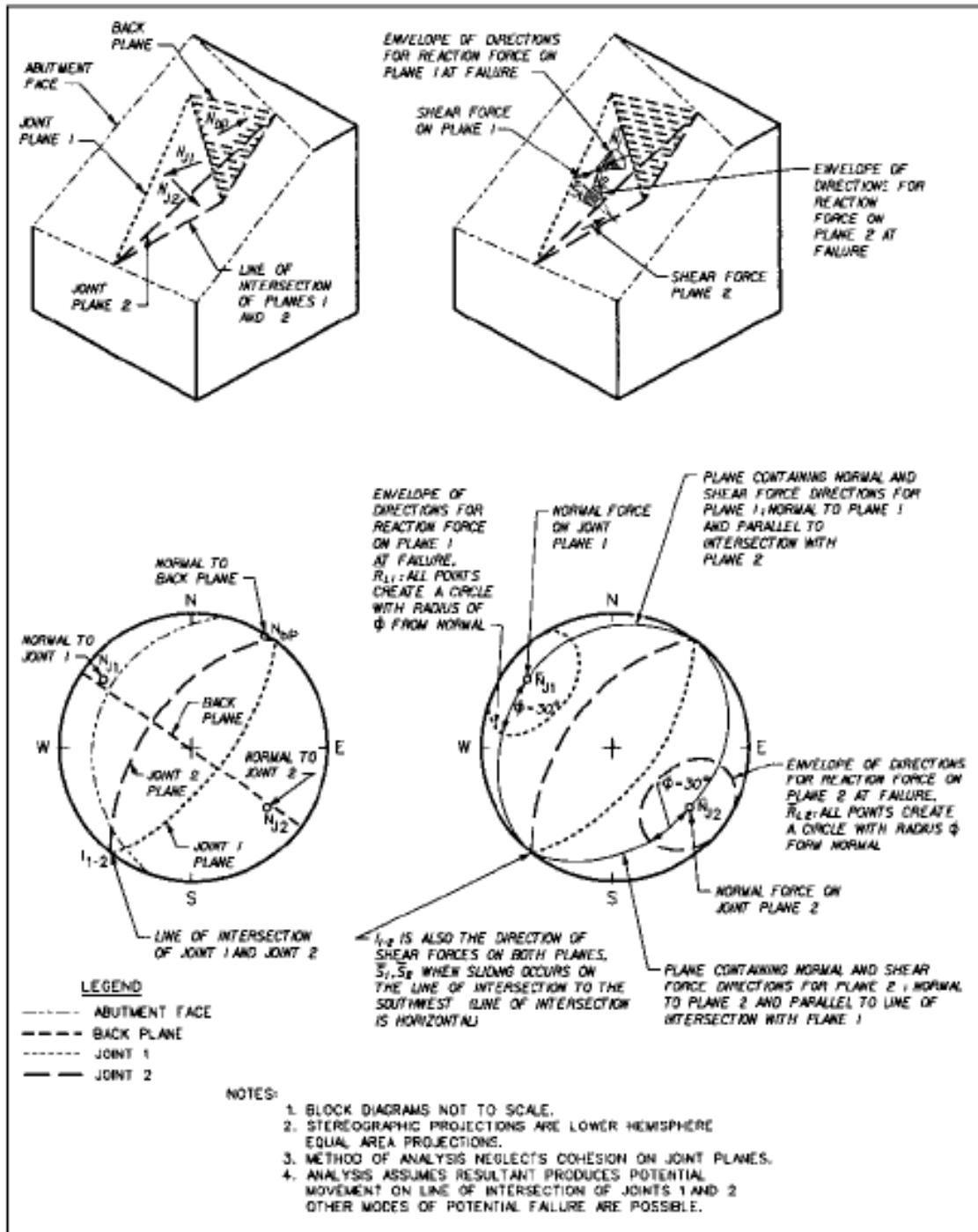

Figure 10-10

Illustration of both the vector and graphical stereonet technique of slope stability analysis from Portugues Dam

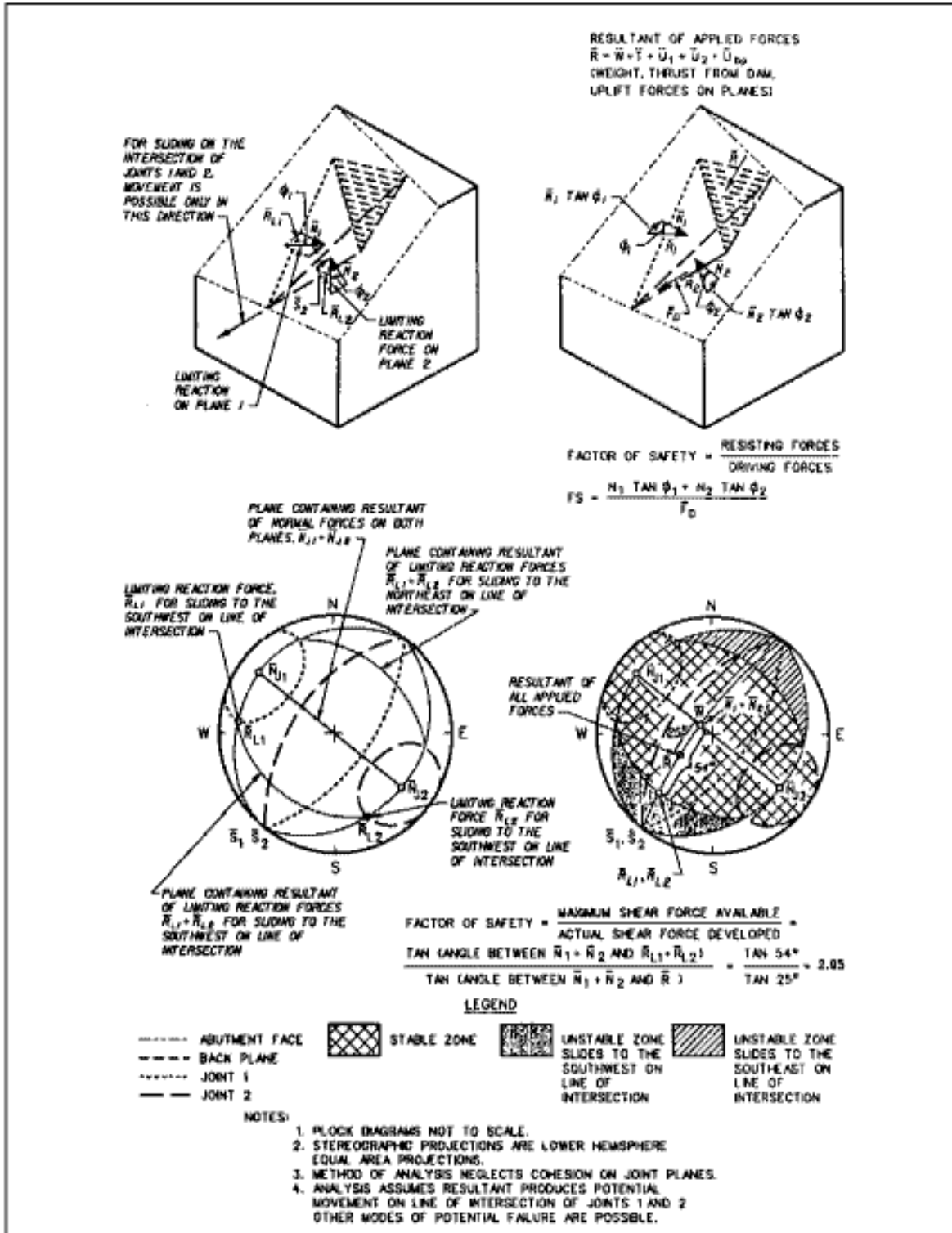

Figure 10-10 (continued)

Illustration of both the vector and graphical stereonet technique of slope stability analysis from Portugues Dam