



**PDHonline Course E353 (2 PDH)**

---

# **Energy Efficient Lighting**

*Instructor: Sonal Desai, Ph.D.*

**2020**

**PDH Online | PDH Center**

5272 Meadow Estates Drive  
Fairfax, VA 22030-6658  
Phone: 703-988-0088  
[www.PDHonline.com](http://www.PDHonline.com)

An Approved Continuing Education Provider

# Energy Efficiency in Lighting

*Sonal Desai, Ph.D.*

## COURSE CONTENT

### Introduction

The content covers lighting fundamentals, lighting systems, control systems, audit methodology and energy saving opportunities.

Lighting has a profound effect on the lives of humans. It facilitates vision and it affects our basic biological functioning through its effect on our 'body clocks'. Significant portion of total energy produced is consumed by lighting system which is essential requirement. Approximately 10 to 15 % of total energy is consumed in lighting in developed country.

Because this energy is often supplied by fossil-fuel generation, provision of lighting results in the large-scale release of greenhouse gases. Further, lighting is a major contributor to the peak demand for electrical power, which is often met by expensive, high-GHG generators. Because of its high-energy burden, lighting has often been the target of energy efficiency initiatives.

### 1 Fundamentals of lighting

Lighting quantity and quality is basically expressed in watts, lumens and illuminance.

**Watt** is the unit for measuring electrical power, it is not a measure of light output. It defines the rate of energy consumption by the lighting system.

**Lumen** is the most common measure of light output. Light sources are labeled with an output rating in lumens. For example, a T12 40-watt fluorescent lamp may have a rating of 3050 lumens. As lamps and fixtures age and become dirty, their lumen output decreases (i.e., lumen depreciation occurs). Thus, the number of lumens describes how much light is being produced by the lighting system.

Light intensity measured on a work plane at a specific location is called **illuminance**, which is measured in foot-candles - work plane lumens per square foot. Foot-candles are the end result of watts being converted to lumens hence its measurements are important. Multiplier of 10.76 converts foot-candles to lux. The concept of watt, lumens and illuminance is shown in figure 1.

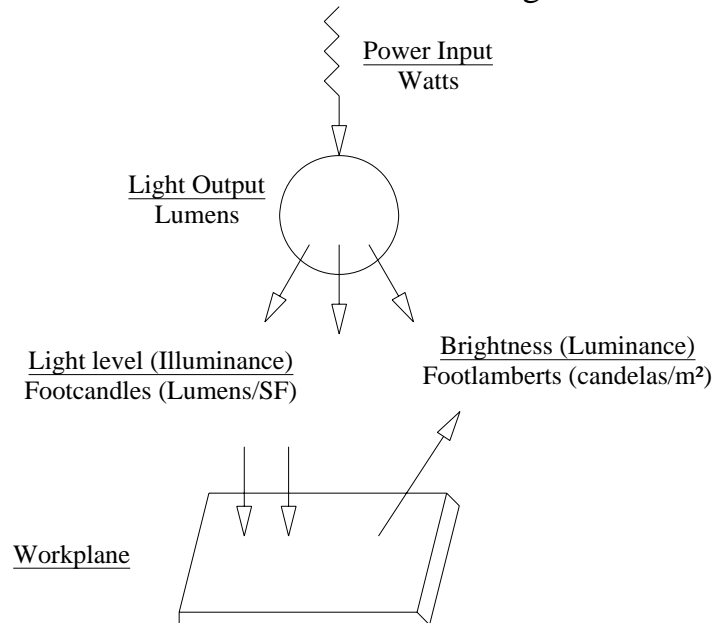

Figure 1 The concept of watt, lumens and illuminance

The output available from the input is termed as efficiency usually in all engineering systems and it is a unit less term. The efficiency of heating system is say 80%. But with lighting system we are concerned with the amount of light (in lumens) produced by a certain amount of electricity (in watts), as a result efficacy is used instead of efficiency. Thus **efficacy** is the lumen output divided by the watts of power input (lumens per watt). Standard incandescent lamps produce 10 to 20 lumens per watt, while fluorescent lamps produce 50 to 90 lumens per watt, and high-pressure sodium lamps as much as 140 lumens per watt.

Few other terms used in lighting systems are glare, visual comfort probability, uniformity of illuminance, color rendition, color rendering index, color temperature etc. are described in following section.

**Glare** is a sensation caused by relatively bright objects in an occupant's field of view. The key word is *relative*, because glare is most probable when bright objects are located in front of dark environments. A good example of glare is

feeling of discomfort by a car driver due to opposite car's high beam headlights during night which is absent during the day.

Contrast is the relationship between the brightness of an object and its background. Although most visual tasks generally become easier with increased contrast, too much brightness causes glare and makes the visual task more difficult. Glare in certain work environments is a serious concern because it usually will cause discomfort and reduce workers productivity and annoyance. The **Visual Comfort Probability** is a rating given to a fixture which indicates the percent of people who are comfortable with the glare. Thus, a fixture with a VCP of 80 means that 80% of occupants are comfortable with the amount of glare from that fixture. A minimum VCP of 70 is recommended for general interior spaces.

The **uniformity of illuminance** describes how evenly light spreads over a task area. Two major factors affecting uniformity are improper fixture placement and narrow distribution of light. Non-uniform illuminance creates several problems like inadequate light levels in some areas, visual discomfort when tasks require frequent shifting of view from under lit to over lit areas and bright and dark spots, which cause discomfort for occupants.

The ability to see colors properly is another aspect of lighting quality. In simple terms, the **Color Rendering Index** CRI provides an evaluation of how colors appear under a given light source. A scale of 0 to 100 defines the CRI. A higher CRI means better color rendering, or less color shift. CRIs in the range of 75-100 are considered excellent, while 65-75 are good. The range of 55-65 is fair, and 0-55 is poor. To provide a base-case, offices illuminated by most T12 Cool White lamps have a CRI of 62.

It is extremely important that a light source with a high CRI be used with visual tasks that require the occupant to distinguish colors. For example, a room with a color printing press requires illumination with excellent color rendition. In comparison, outdoor security lighting for a building may not need to have a high CRI, but a large quantity of light is desired.

**Color temperature** is a measurement of warmth or coolness provided by the lamp. It refers to the color of a blackbody radiator at a given absolute temperature, expressed in Kelvins. A blackbody radiator changes color as its temperature increases (first to red, then to orange, yellow, white, and finally bluish white at the highest temperature). A warm color light source actually has a lower color temperature. For example, a cool-white fluorescent lamp appears bluish in color

with a color temperature of around 4100 K. A warmer fluorescent lamp appears more yellowish with a color temperature around 3000 K. Laboratories, hospitals and grocery stores generally use “cool” (blue-white) sources, while expensive restaurants may seek a “warm” (yellow-red) source to produce a candle-lit appearance.

## 2 Different lighting systems

There are different lighting systems available commercially and used for industrial and household applications. They are having specific advantages, life cycle, color qualities etc

In general there are three types of lamps commonly used.

1. Incandescent lamp
2. Fluorescent lamp
3. High intensity discharge lamp
4. Light emitting diodes

### *Incandescent lamp*

The oldest electric lighting technology is the incandescent lamp. Incandescent lamps are also the least efficient and have the shortest life. They produce light by passing a current through a tungsten filament, causing it to become hot and glow. As the tungsten emits light, it gradually evaporates, eventually causing the filament to break. When this happens, the lamps is said to be “burned-out.” Although incandescent sources are the least efficacious, they are still sold in great quantities because of low cost. However, if life-cycle cost analyses are used, incandescent lamps are usually more expensive than other lighting systems with higher efficacies. An incandescent lamp and common shapes are shown in figure 2.

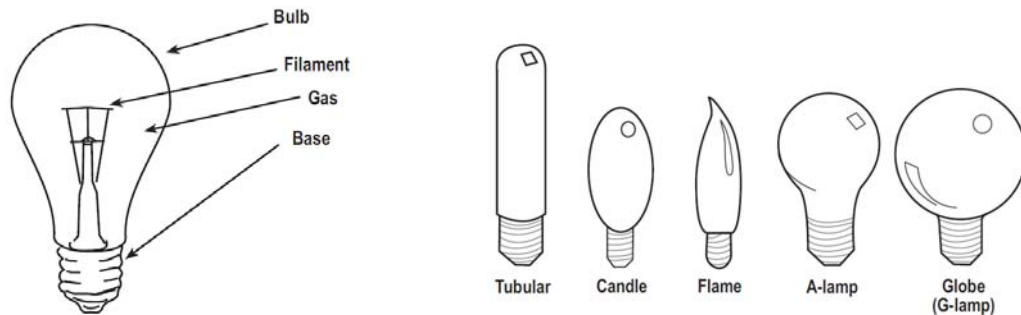

Figure 2 Construction of a typical incandescent lamp and common shapes

***Compact fluorescent lamps (CFLs)***

Compact Fluorescent Lamps (CFLs) are energy efficient, long lasting replacements for incandescent lamps. They are made of two parts, the lamp and the ballast. The short tubular lamps can last longer than 8,000 hours. The ballasts (plastic component at the base of tube) usually last longer than 60,000 hours which is 7 to 10 times longer than incandescent lamp. They are available in many styles and sizes as shown in figure 3.

Compared to incandescent lamps CFLs provide similar light quantity and quality while only requiring about 20-30% of the energy.

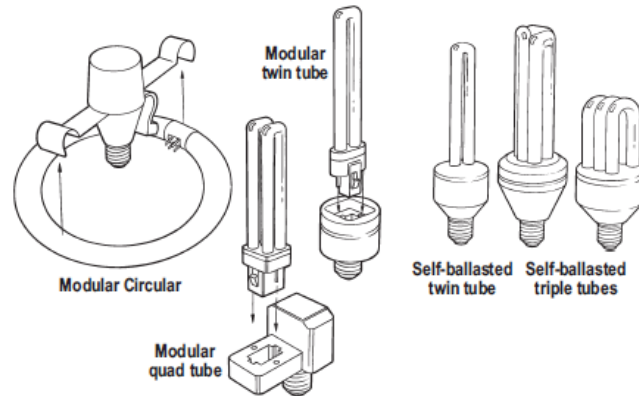

Figure 3 Different types of compact fluorescent lamps.

***Fluorescent lamps***

A fluorescent lamp or fluorescent tube is a gas discharge lamp that uses electricity to excite mercury vapor. The excited mercury atoms produce short-wave ultraviolet light which causes a phosphor to fluoresce, producing visible light. The most common light source used for interiors of the buildings are fluorescent lights as they are more efficient compared to incandescent lamps, have long lives and are available in different shapes and styles. Till recently they are used with magnetic ballast, which are rapidly replaced by T12, T8 or T5 lamps with electronic ballasts. The labeling system on fluorescent system is F34T12, where F stands for fluorescent, 34 stands for 34 watts, and the T12 refers to the tube thickness of 12/8 inches.

***High intensity discharge lamp (HID)***

High-Intensity Discharge (HID) lamps are similar to fluorescent lamps because they produce light by discharging an electric arc through a tube filled with gases with the difference that they generate much more light, heat and pressure within the arc tube than fluorescent lamps, hence they are called high intensity

discharge. Normally HID's are used for outdoor and industrial applications, HID's are also used in office, retail and other indoor applications. HID's require more time to warm up and should not be turned ON and OFF for short intervals also they are not suitable for certain applications because they serve as point source of light. Most HID's have relatively high efficacies and long lamp lives.

Different HID sources are listed in increasing order of efficacy as:

1. mercury vapor
2. metal halide
3. high pressure sodium
4. Flow pressure sodium

### ***Mercury vapor***

Mercury Vapor systems were the "first generation" HID's. Clear mercury vapor lamps, which produce a blue green light, consist of a mercury-vapor arc tube with tungsten electrodes at both ends. These lamps have the lowest efficacies, rapid lumen depreciation, and a low color rendering index of different HID's. Because of these, a popular lighting upgrade is to replace Mercury Vapor systems with Metal Halide or High Pressure Sodium systems.

### ***Metal halide***

These lamps are similar to mercury vapor lamps but use metal halide additives inside the arc tube along with the mercury and argon. These additives enable the lamp to produce more visible light per watt with improved color rendition.

Wattages range from 32 to 2,000, offering a wide range of indoor and outdoor applications. The maintained efficacy of metal halide lamps ranges from 50 to 115 lumens per watt (typically about double that of mercury vapor). In short, metal halide lamps have several advantages like high efficacy, good color rendering and wide range of wattages and used in industrial facilities, sports arenas and other spaces where good color rendition is required. Figure 4 shows construction details of high pressure mercury vapor lamp and metal halide lamp.

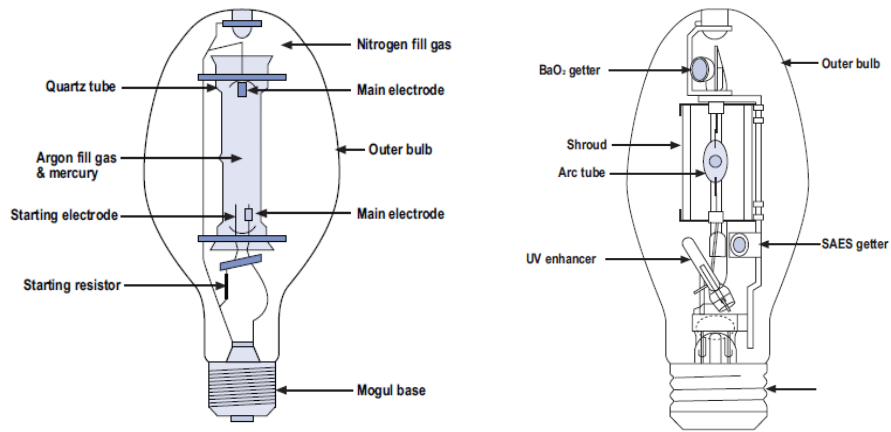

Figure 4 Construction of a high-pressure mercury vapor lamp and metal halide lamp

Source : IESNA Lighting Handbook -9th Edition.

### ***High pressure sodium (HPS)***

With a higher efficacy than Metal Halide lamps, HPS systems as shown in figure 5 are an economical choice for most outdoor and some industrial applications where good color rendition is not required. HPS is commonly used in parking areas. Although HPS lamps do not provide the best color rendition, (or attractiveness) as “white light” sources, they are adequate for indoor applications at some industrial facilities. HPS lamps differ from mercury and metal-halide lamps in that they do not contain starting electrodes; the ballast circuit includes a high-voltage electronic starter. The arc tube is made of a ceramic material which can withstand temperatures up to 1300°C. It is filled with xenon to help start the arc, as well as a sodium-mercury gas mixture. Sodium, the major element used, produces the golden color that is characteristic of HPS lamps. Although HPS lamps are not generally recommended for applications where color rendering is critical, HPS color rendering properties are being improved. Some HPS lamps are now available in deluxe and white colors that provide higher color temperature and improved color rendition.



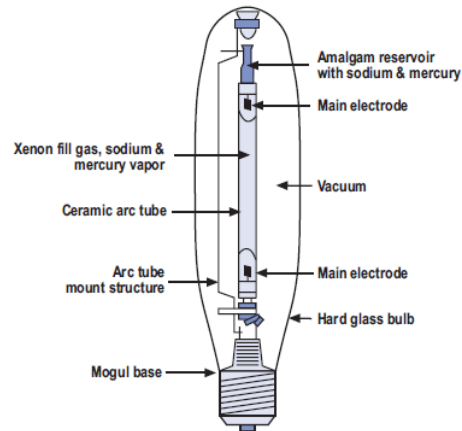

Figure 5 Construction of a high-pressure sodium lamp.

### ***Low pressure sodium***

Although LPS systems have the highest efficacy of any commercially available HID, this light source produces the poorest color rendition of all lamp types. Being a monochromatic light source, all colors appear black, white, or shades of gray under an LPS source. LPS lamps are available in wattages ranging from 18-180 and their applications are limited to security or street lighting.

Because the LPS lamps are physically long (like fluorescent), they are less effective in directing and controlling a light beam, compared with point sources like high-pressure sodium and metal halide therefore, lower mounting heights are necessary. LPS has become popular because of its extremely high efficacy.

### ***Light emitting diodes (LEDs)***

A long-term research has suggested that development of white-light LEDs will replace all other lighting source by 2025 as they are cost-effective, market-ready systems producing 160 lm/W.

If we compare LEDs with present market leader CFLs, the most efficacious LEDs have very high correlated color temperatures, often above 5000K, producing a “cold” bluish light. However, warm white LEDs (2600K to 3500K) have improved significantly, now approaching the efficacy of CFLs. In addition to warmer appearance, LED color rendering is also improving: leading warm white LEDs are now available with color rendering index (CRI) of 80, equivalent to CFLs.

As a matter of fact that fluorescent and high-intensity discharge (HID) light sources cannot function without a ballast, which provides a starting voltage and

limits electrical current to the lamp. Similarly, LEDs require a power supply commonly called a “driver”. The power supply converts line (AC) power to the appropriate DC voltage (typically between 2 and 4 volts DC for high-brightness LEDs) and current (generally 200-1000 milliamps, mA), and may also include supplementary electronics for dimming and/or color correction control. Currently available LED drivers are typically about 85% efficient. So LED efficacy should be discounted by 15% to account for the driver.

Luminous efficacy is an important indicator of energy efficiency, but it doesn't tell the whole story, particularly with regard to directional light sources. Due to the directional nature of their light emission, LEDs potentially have higher application efficiency than other light sources in certain lighting applications. Fluorescent and incandescent lamps emit light in all directions. Much of the light produced by the lamp is lost within the fixture, reabsorbed by the lamp, or escapes from the fixture in a direction that is not useful for the intended application. For many fixture types it is not uncommon for 40-50% of the total light output of the lamp(s) to be lost before it exits the fixture, while in case of LEDs, they emit light in a specific direction, reducing the need for reflectors and diffusers that can trap light, so well-designed fixtures can deliver light more efficiently to the intended location. Typical LED shapes are shown in figure 6.

General information of different types of lamps are presented in table 1.

	Incandescent		Fluorescent		HID	
	Standard	Halogen	Full-size or U-Bent	Compact	Metal Halide	High pressure sodium
Wattage	3-1,500	10-1,500	4-215	5-58	32-2,000	35-1,000
Lamp Efficiency	6-24	8-35	26-105	28-84	50-110	50-120
Average Rated Life (Hours)	750-2,000	2,000-4,000	7,500-24,000	10,000-20,000	6,000-20,000	16,000-24,000
CRI (%)	99	99	49-96	82-86	65-96	21-65
Start-To-Full Brightness	Immediate	Immediate	0-5 Seconds	0-5 Minutes	1-15 Minutes	4-6 Minutes
Re-Strike Time	Immediate	Immediate	Immediate	Immediate	2-20 Minutes	1 Minutes
Lumen Maintenance	Very Good	Excellent	Very Good	Good	Fair/Good	Very Good

Table 1.1 General Information of different types of lamps

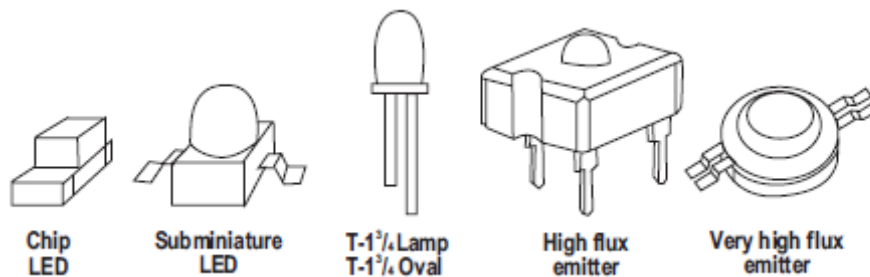

Figure 6 Typical LED shapes.

### 3 Ballasts

All discharge lamps (fluorescent and HID) require an auxiliary piece of equipment called a ballast. It has three main functions. 1. Provide correct starting voltage, because lamps require a higher voltage to start than to operate 2. Match the line voltage to the operating voltage of the lamp and 3. Limit the lamp current to prevent immediate destruction, because once the arc is struck the lamp impedance decreases. As ballasts are an integral component of the lighting system, they have a direct impact on light output. The ballast factor is the ratio of a lamp's light output using the selected ballast, compared to the lamp's rated light output as listed in lamp catalogs. General purpose ballasts have a ballast factor that is less than one (typically .88 for most electronic ballasts); special ballasts may have higher ballast factors to increase light output.

The two general types of fluorescent ballasts are magnetic and electronic ballasts.

#### ***Magnetic ballast***

Magnetic ballasts are available in three primary types.

- Standard core and coil
- High-efficiency core and coil (Energy-Efficient Ballasts)
- Cathode cut-out or Hybrid

Standard core and coil magnetic ballasts are essentially core and coil transformers that are relatively inefficient at operating fluorescent lamps. The high-efficiency ballast upgrades the aluminum wiring and lower grade steel of the standard ballast with copper wiring and enhanced ferromagnetic materials, improving the system efficiency by approximately 10%. Cathode cut-out or hybrid ballasts are high-efficiency core and coil ballasts that incorporate electronic components that cut off power to the lamp cathodes after the lamps are operating, resulting in an additional 2-watt savings per lamp.

### ***Electronic Ballasts***

In nearly every full-size fluorescent lighting application, electronic ballasts will be used in place of conventional magnetic core-and-coil type ballasts. Electronic ballasts improve fluorescent system efficacy by converting the standard 60 Hz input frequency to a higher frequency, usually 25,000 to 40,000 Hz. Lamps operating at these higher frequencies produce about the same amount of light, while consuming 12 to 25 percent less power. Other advantages of electronic ballasts include less audible noise, less weight, virtually no lamp flicker, and dimming capabilities. Electronic ballast are designed to operate up to four lamps at a time. In addition parallel wiring is another feature that allows all companion lamps in the ballast circuit to continue operating in the event of a lamp failure.

In a typical magnetic, (series- wired system) when one component fails, all lamps in the fixture shut OFF. Before maintenance personnel can relamp, they must first diagnose which lamp failed. Thus the electronically ballasted system will reduce time to diagnose problems. Due to long list of advantages many manufacturers produce them at competitive rates.

### ***HID ballast***

As with fluorescent systems, High Intensity Discharge lamps also require ballasts to operate. The purposes of the ballast are similar: to provide starting voltage, to limit the current, and to match the line voltage to the arc voltage. HID ballasts are available in dimmable and bi-level light outputs. “Bi-level” HID fixtures are designed to provide either full or partial light output based on inputs from occupancy sensors, manual switches or scheduling systems. General purpose transmitters can be used with other control devices such as timers and photo sensors to control the bi-level fixtures. Wrong HID ballast may result in waste of energy, increased operating cost, severely shorten lamp life, significantly addition to system maintenance costs, lower-than-desired light levels and increased wiring and circuit breaker installation costs.

## **4 Fixtures (luminaries)**

A fixture is a unit consisting of the lamps, lamp sockets, ballasts, reflectors, lenses or louvers and housing. The main function is to focus or spread light emanating from the lamp(s). Without fixtures, lighting systems would appear very bright and cause glare. There are several different types of luminaries. The following is a list of some of the common luminaries types.

- general illumination fixtures such as 2x4, 2x2, & 1x4
- fluorescent for direct lighting

- indirect lighting
- spot or accent lighting
- task lighting
- outdoor area and flood lighting

The efficiency of a fixture is the percentage of lamp lumens produced that actually exit the fixture in the intended direction. The use of louvers can improve visual comfort, but because they reduce the lumen output of the fixture, efficiency is reduced. Generally, the most efficient fixtures have the poorest visual comfort. Conversely, the fixture that provides the highest visual comfort level can be the least efficient. Thus, a lighting designer must determine the best compromise between efficiency and visual comfort probability when specifying luminaries. Surface deterioration and accumulated dirt in older, poorly maintained fixtures can also cause reductions in fixture efficiency.

## 5 Reflectors

Reflectors are designed to redirect the light emitted from a lamp in order to achieve a desired distribution of light intensity outside of the fixture. In most incandescent spot and flood lights, highly specular reflectors are usually built into the lamps.

One energy-efficient upgrade option is to install a custom-designed reflector to enhance the light control and efficiency of the fixture, which may allow partial delamping. Retrofit reflectors are useful for upgrading the efficiency of older, deteriorated fixture surfaces. In addition, reflectors will redistribute light (usually more light is reflected down), which may create bright and dark spots in the room. To ensure acceptable performance from reflectors, conduct a trial installation and measure “before” and “after” light levels at various locations in the room.

A variety of reflector materials are available: highly reflective white paint, silver film laminate, and standard or enhanced grades of anodized aluminum sheet. Silver film laminate is generally considered to have the highest reflectance, but is less durable. In addition to installing reflectors within fixtures, light levels can be increased by improving the reflectivity of the room’s walls, floors and ceilings.

## 6 Lenses and Louvers

Most indoor commercial fluorescent fixtures use either a lens or a louver to prevent direct viewing of the lamps. Light that is emitted above 55 degrees from the fixture's vertical axis can cause visual discomfort and reflections, which reduce contrast on work surfaces or computer screens. Lenses and louvers can control this situation. Lenses which are made from clear ultraviolet stabilized acrylic plastic deliver the most light output and uniformity of all shielding media. However, they provide less glare control than louvered fixtures. Clear lens types include prismatic, batwing, linear batwing, and polarized lenses. Lenses are usually much less expensive than louvers. White translucent diffusers are much less efficient than clear lenses, and they result in relatively low visual comfort probability. New low-glare clear lens materials are available for retrofit and provide high visual comfort and efficiency.

Louvers provide superior glare control and high visual comfort compared with lens-diffuser systems. The most common application of louvers is to eliminate the fixture glare reflected on computer screens.

## 7 Lighting Control Systems

Due to the increase of environmental concerns, lighting control systems play an important role in the reduction of energy consumption of the lighting without impeding comfort goals. Hence, Lighting control is continuously evolving for visual comfort and demand for lighting energy savings.

Different parameters are to be studied before deciding type of lighting control system like visual performance and comfort, building energy use, cost effectiveness, ease of use, maintenance, flexibility, versatility, existing building constraints, stability, integration etc. Different lighting control systems are discussed in following section.

### ***Timers (Time scheduling control system)***

Time scheduling control system is used to reduce the operating hours of the lighting installation by turning lighting on and off on a preset daily time schedule. Schedules usually vary on a daily basis according to the building occupancy. Different schedules can be programmed for different areas of the building based on the occupant needs. The time scheduling control strategy enables switching on or off automatically based on time schedules and occupancy patterns for

different zones. Twenty-four hour timers allow the occupants to set certain times for lighting.

### ***Dimmer***

Dimming systems adapt the light levels gradually, and thus reduce power and light output gradually over a specified range. Dimming can generate important energy savings. However, dimming hardware/devices are more expensive than switching devices. The dimming can be achieved through two modes:- Continuous dimming or Step by step dimming.

Continuous dimming is a continuous adaptation of the luminous flux of the light source(s) in function of external information. Most of the time, this kind of dimming is achieved through a DC control command on the ballast of the luminaire (discharge lamp) or through the transformer (halogen lamp). Some manufacturers have adopted a standard analogue 0-10 V dimming protocol that allows ballasts from different manufacturers to be used with compatible systems.

Step by step dimming is a way to control the light output of the luminaires based on a limited number of configurations. The rated dimming levels are based on information generated by the controller, received by the actuator and transmitted to the light source. Switching systems perform very well in climates with stable sky conditions, while dimming systems is predisposed to save more energy in climates with variable sky conditions.

### ***Photocell***

For most outdoor lighting applications, photocells which turn lights ON when it gets dark, and off when sufficient daylight is available offers a low-maintenance alternative to time clocks. If combined with dimmers photocell measures the lighting level within a space, on a surface or at a specific point. If the light level is too high, the system's controller reduces the lumen output of the light sources. If the light level is too low, the controller increases the lumen output of the light sources. Sensors are often used in large areas, each controlling a separate group of lights in order to maintain a uniform lighting level throughout the area. The result is a system that minimizes lighting energy use while maintaining uniform lighting levels. This system can also provide the constant illuminance strategy.

### ***Infrared presence sensors***

Infrared presence sensors detect the presence of occupants by detecting their movements. The most common sensors used in the building sector are passive infrared (PIR) sensors that react to variations of infrared radiations due to

movement of persons. The system consists of a sensor and a control unit with coverage of approximately 130 square feet per sensor. Sensors are mounted on the ceiling and usually directed towards specific work stations and can be combined with HVAC control unit.

The infrared presence sensors have some disadvantages like some human activities are achieved without any movement. e.g. watching television, reading book, sleep, etc. also they are position sensitive and may be irrelevant if looking to a dead zone.

### ***Ultrasonic Presence sensor***

Ultrasonic devices send out inaudible sound waves. At the same time, a device is scanning for sound waves which are reflected at a specific rate. If a change in the reflected wave is detected, it indicates that something or someone has moved in the detection zone.

There are products combining the two technologies, called as Dual Technology sensors. They see and hear the occupant so that presence is detected even if there is no movement.

When lighting systems are connected to a Facility Management System (FMS), greater control options can be realized. The FMS could control lights, air conditioner etc to turn OFF during non-working hours, except when other sensors indicate that a space is occupied.

## **8 Lighting system audit**

Audit of lighting system includes measurement of illumination levels, improving lighting system efficiency, reducing operating hours, checking possibilities of retrofits and use of suitable lighting control devices.

Energy audit of lighting system depends on end user of it and hence has to be tailor made. General procedure to audit lighting system is mentioned below:

### **Step :1 (Observation)**

- A. Identify the room type- e.g. office, warehouse, storage, etc.
- B. Observe the room dimensions and characteristics- e.g. height, width, length, color, surface condition etc.
- C. Count number of lamps, lamp type, type of fixture, condition of fixture etc.
- D. Find type of control used for lighting system.



E. Identify the task / operation performed by occupant / resident.

Step :2 (Output Measurement)

- A. Measure illuminance using lux meters at various plant locations at work plan level. (Ensure sufficient number of measurement points and proper positioning of measuring device)
- B. Prepare sketch of fixtures layout in the room area.
- C. Check for excessive glare and contrast.
- D. Estimate electrical consumption,
- E.

$$Annual\ lighting\ cost = Annual\ working\ hours \times number\ of\ lamps \times watts\ per\ lamp \times \frac{rate}{kWh} \quad \text{-----}1$$

If lamps are of different capacity than calculate accordingly.

F. Calculate installed load efficacy,

$$Load\ efficacy = \frac{Average\ luminance\ on\ the\ working\ plane}{Circuit\ watt} \quad \text{-----}2$$

Step :3 (Input Measurement)

- A. Measure and document voltage, current and power factor at the nearest point of lighting system with power analyzer. If total power is not measurable, try to measure power consumption of at least 1 or 2 lamps and calculate the total power consumption.

Step :4 (Compilation of results)

- A. Compare measured input value (step 3) with calculated output value (step 4). Try to identify the choices of retrofits where gap exists.
- B. Identify under lit and over lit areas.
- C. Analyze the failure rate or lamp and ballast from the history if available.
- D. Suggest suitable lighting control device to reduce number of working hours.
- E. Prepare checklist to improve lighting system efficiency.

Step 5: (ILER analysis)

A. Calculate Room Index,

$$Room\ index = \frac{L \times W}{H_m \times (L + W)} \quad \text{-----}3$$

where L, W and H<sub>m</sub> are room length, width and mounting heights respectively.

B. Calculate ILER,

$$\text{Installed load efficacy ratio} = \frac{\text{Installed load efficacy}}{\text{Target Installed Load Efficacy}} \text{-----}4$$

Refer table 2 for target installed load efficacy

C. Evaluate ILER range from table 3. Major reasons for lower ILER are inefficient lamp / ballast, improper mounting height, poor and dirt accumulated reflectors, low voltage etc.

Room Index	Commercial & Clean Industrial areas with CRI = 40-85	Industrial lighting with CRI = 40-85	Industrial lighting with CRI = 20-40
1	36	33	52
1.25	40	36	55
1.5	43	39	58
2	46	42	61
2.5	48	44	64
3	50	46	65
4	52	48	66
5	53	49	67

Table 2 Target Installed Load Efficacy

ILER	Assessment
0.75 or above	Satisfactory to good
0.51 to 0.74	Review suggested
0.5 or less	Urgent action required

Table 3 ILER range

## 9 Energy Saving Opportunities

To identify energy saving opportunities in lighting system it is essential to identify the proper lighting quantity and quality. Next to it is to increase light

source efficiency if occupancy is frequent and if occupancy is infrequent use suitable lighting controls.

It is generally observed that in certain installations, power quality is poor. Both planned and unplanned interruptions happen; line voltage varies. Besides, spikes and surges are common. All these problems contribute to the reduced lamp/ballast life and lead to an increased need for lamp/e-choke replacements and hence higher operation and maintenance costs. However effective use of energy saving opportunity will definitely lead us for assured energy savings. Few energy saving opportunities are discussed in following section:

### ***Daylighting***

Daylight is the ideal light source, both in terms of quality and energy use. A single skylight provides as much light as a dozen or more light bulbs, and the light quality is unsurpassed. People feel that exposure to natural daylight is conducive to good health. But too much natural lighting – especially glare – can be distracting. Skylights and windows have to be designed carefully so they don't contribute to overheating. The potential for overheating from skylights will vary, depending on the pitch of roof and the direction its facing. Also skylights need some exterior shading placed over them in the summer. Greenhouse shading material is commonly used for this purpose. If not shaded, windows can admit considerable amounts of unwanted solar heat in summer and contribute to overheating.

A new way to add daylighting to a room is with a skylight tube as shown in figure 1.7. These devices consist of a lens that is installed on the roof, an adjustable mirror-lined tube of 10" to 20" diameter that passes through the attic, and a light fixture that is installed in the ceiling. Skylight tubes bring daylight into the house with much less disruption of roof and ceiling construction than is required for ordinary skylights. Modern buildings designed for daylighting typically use 40 to 60% less electricity for lighting needs than do more conventionally designed buildings. A good design incorporating sky lights with FRP material along with transparent or translucent false ceiling can provide good glare-free lighting.

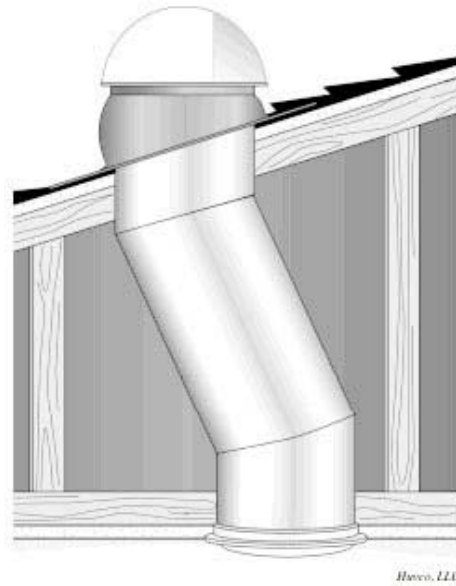

Figure 7 A typical Skylight tube

### ***Task lighting***

It was suggested by researchers that provision of task lighting as a supplement to preferred levels of ambient lighting led to improvements in performance on tasks because they illuminate what is necessary. Ambient or general lighting provides even, overall illumination while task lighting provides the light needed for a particular task such as reading, computer work, assembling, etc. It is observed that Combination of ambient and task lighting increases workers efficiency.

### ***Solar powered lighting***

Another way to power lighting, particularly for outdoor lights are to use solar energy. A photovoltaic (PV) panel uses the solar energy of the sun to generate electricity, which is stored in a battery. The energy stored in the battery can be used to provide electric power to the outdoor lights. Solar powered lights work very effectively as patio and walkway lights, security lights, and to accomplish different landscape lighting effects in the garden. Solar lighting is versatile because no wiring is required and they can be moved around to achieve different effects.

### ***Group Re-lamping***

The largest cost of a lighting system to a commercial user is not initial cost of lamps and installation, but energy and maintenance costs. The largest lighting maintenance cost is relamping changing the burned out light bulbs. It is not the cost of the lamp itself that is expensive, but the labor involved, and the disruption

to business. One of the best ways to minimize these costs is to use a practice called *Group Relamping*.

In a typical non-group relamping procedure, when a lamp burns out in the workplace, it is replaced individually with a new lamp as soon as possible. This is called spot relamping and it proves to be a very inefficient use of maintenance staff time and hence a non economical solution. In spot relamping first, the location must be identified and communicated to the maintenance staff and then there is a site visit required to assess the need which is followed by a new lamp purchase and installation procedure. Hours or days later another lamp burns out somewhere else and the process is repeated. This can take a lot of time, disrupt worker or customer operations, and introduce safety concerns.

With the use of group relamping procedures, all of the lamps in an area are installed at once and then at a predetermined interval all of the lamps are replaced, before they start burning out on a regular basis. This allows a trained maintenance staff members to schedule access to an area, bring in all the necessary equipment and supplies, work in an efficient manner (possibly at night, on the weekend or some other scheduled downtime), and then leave that area until the next scheduled group relamping.

Determining the group relamping schedule is based on a number of variables like lamp life, annual hours of use, and lamp lumen depreciation and power quality which may range from 70% to 80% of rated lamp life. There will be some lamps that will burn out prior to this time and should be spot relamped as needed. This option provides more ease compared to energy saving.

### ***De-lamping***

De-lamping is used to reduce excessive illuminance is an effective method to reduce lighting energy consumption. In some industries, reducing the mounting height of lamps, providing efficient luminaries and reducing number of lamps has ensured that the illuminance is marginally affected. Performing de-lamping at dead corners where active work is not being performed is also a useful concept.

### ***Retrofits***

Energy efficient lighting retrofits are beneficial for most of the buildings. Replacing aged lighting devices with advanced and energy efficient lighting devices can save as much as 40% of a energy bill while enhancing the quality of light. Most of the lighting retrofits have simple payback of less than three years.

When retrofits are advisable?

Under one or more of the following condition retrofit of lighting system is advisable.

- Excessive illuminance or over lit situation.
- Lighting technology is older than 10 years
- Lighting system has crossed their useful life and poorly maintained.
- Excessive hours of lighting operations
- High electricity charges

Some common examples of lighting retrofits are presented here:

#### *Use of metal halide lamp*

Installation of metal halide lamps in place of mercury / sodium vapor lamps. Metal halide lamps provide high color rendering index as these lamps offer efficient white light. Hence, metal halide is the choice for color critical applications where, higher illumination levels are required. These lamps are highly suitable for applications such as assembly line, inspection areas, painting shops, etc.

#### *Use of high pressure sodium vapor lamp*

Installation of High Pressure Sodium Vapor (HPSV) lamps for applications where color rendering is not critical as they offer more efficacy. But the color rendering property of HPSV is very poor hence, it is recommended to install HPSV lamps for applications such street lighting, yard lighting, etc.

#### *Use of Light emitting diode (LED) lamp*

Installation of LED panel indicator lamps in place of filament lamps for applications like indicators, signal, traffic light indicators etc. will result in lesser power consumption and longer life.

#### *Use of electronic ballast*

As mentioned in earlier section conventional electromagnetic ballasts (chokes) are used to provide higher voltage to start the tubular light and subsequently limit the current during normal operation. Electronic ballasts are oscillators that convert the supply frequency to about 20,000 Hz to 30,000 Hz. The losses in electronic ballasts for tubular lights are only about 1 Watt, in place of 10 to 15 Watts in standard electromagnetic chokes. The additional advantage is that the efficacy of tubular lights improves at higher frequencies. Hence a saving of about 15 to 20 Watts per tubular light can be achieved by use of electronic ballasts.

With electronic ballast, the starter is eliminated and the tubular light starts instantly without flickering. The energy saving potential of electronic ballast retrofits is listed in table 4.

Type Of Lamp	With Conventional Electromagnetic Ballast	With Electronic Ballast	Power Savings, Watt
40 W Tubular light	51	35	16
35 W Low Pressure Sodium	48	32	16
70 W High Pressure Sodium	81	75	6

Table 4 Effect of electronic ballast

### ***Select T5 Fluorescent Tubular Lights***

The Fluorescent tubular lights presently used commercially are T12 (40W) and T8 (36W). T12 has tube diameter of 12/8" (33.8mm) and T8 has tube diameter of 8/8" (26mm) while that of T5 is 5/8" (16mm). The advantage of the T5 lamps is due to its smaller diameter, luminaries efficiencies is increased by approximately 5%. Also with the use of super-reflective aluminum luminaries of higher efficiency, T5 lamps can effect an overall efficiency improvement ranging from 11% to 30%. Additional advantage of T5 lamp is they have a coating on the inner side of the glass wall that stops mercury being absorbed into the glass and the phosphors. This drastically reduces the need for mercury from about 15 milligrams to 3 milligrams per lamp. However, the disadvantage of T5 lamp is it is 50mm shorter in length than T12 and T8 lamps, which restricts the use of existing luminaries. T5 lamps are available in ratings of 14W, 21W, 28W and 35W.

### ***Energy Efficient Street Lighting***

Street light contribute to peak power consumption of electricity. Through use of efficient technologies and designs, excess energy use can be reduced.

- Converting mercury vapor lamp to more efficient metal halide lamp and using more efficient fixtures.
- Proper spacing between street light poles and selecting appropriate mounting heights will make an area safer and secure.

- Use of control device like electronic timer, nature switch and dimmable ballast will potentially reduce energy consumption.
- Line voltage regulator and power factor improvement technique will lengthen the life of lighting devices.
- Centralized control using GSM or SCADA technique will help to control number of glowing hours.

## 10 Checklist

A common checklist for all types of lighting application is presented in this section

1. Relocate work stations near window or sufficiently lit area.
2. Use as much natural day light as possible by use of translucent roofing sheets.
3. Minimize illuminance in non- task areas by reducing the wattage of lamps or number of fittings
4. Look for the Energy Star label when purchasing new lighting products.
5. Avoid use of incandescent/tungsten filament lamps.
6. If you choose to continue using incandescent bulbs, use one high-wattage bulb in place of multiple low wattage bulbs wherever possible. Use incandescent bulbs that are energy efficient and avoid long-life bulbs. Also use reflectors.
7. If you need a lot of outside illumination (for a tennis court or swimming pool, for example), consider replacing incandescent lights with HID lights (either high-pressure sodium or metal halide).
8. Use electronic ballasts in place of conventional ballast for fluorescent lamps.
9. Task lighting saves energy, utilize it whenever possible.
10. Group visual tasks having the same illuminance requirements, and avoid widely separated workstations.
11. All surfaces absorb light to some degree and lower their reflectance. Light colored surfaces are more efficient and need to be regularly painted or washed in order to ensure economical use of light.
12. Maintenance is very important factor. Evaluate present lighting maintenance program and revise it as necessary to provide the most efficient use of lighting system.
13. Clean luminaries, ceilings, walls, lamps etc. on a regular basis.
14. Controls are very effective for reducing lighting cost. Provide separate controls for large ratings.



15. Install switching or dimmer controls to provide flexibility when spaces are used for multiple purposes and require different amounts of illumination for various activities.
16. Switching arrangements should permit luminaires or rows of luminaires near natural light sources like windows or roof lights to be controlled separately.
17. Use separate lighting feeder and maintain the feeder at permissible voltages by using transformers.
18. If a control system is used, check compatibility of lamps and ballasts with the control device.
19. During night time grid voltages are higher than day time. Hence reduction in lighting feeder voltage can save the energy with little compromise of lumen level.
20. Install occupancy sensors for indoor cabin light controls.
21. Dispose of all fluorescent light bulbs as per disposal instruction.
22. Install lamps with the highest efficacies to provide the desired light source color and distribution requirements.
23. Use light colors for walls, floors, ceilings and furniture to increase utilization of light, and reduce connected lighting power to achieve required illuminances. Avoid glossy finishes on room and work surfaces to limit reflected glare.
24. Trim trees and bushes that may be obstructing outdoor luminaire distribution and creating unwanted shadow.
25. Replace outdated or damaged luminaires with modern ones which have good cleaning capabilities and which use lamps with higher efficacy and good lumen maintenance characteristics.