



PDHonline Course E488 (4 PDH)

Introduction to Motor Starting Analysis

Instructor: Velimir Lackovic, MScEE.

2020

PDH Online | PDH Center

5272 Meadow Estates Drive
Fairfax, VA 22030-6658
Phone: 703-988-0088
www.PDHonline.com

An Approved Continuing Education Provider

Introduction to Motor Starting Analysis

Velimir Lackovic, MScEE, P.E.

1. Introduction

This course discusses benefits obtained from motor-starting studies and examines various types of computer-aided studies normally involved in motor-starting studies. Data or information required for these studies as well as the expected results of a motor-starting study effort is also reviewed.

2. Need for motor-starting studies

Motors on modern industrial systems are becoming increasingly larger. Some are considered large even in comparison to the total capacity of large industrial power systems. Starting large motors, especially across-the-line, can cause severe disturbances to the motor and any locally connected load, and also to buses electrically remote from the point of motor starting. Ideally, a motor-starting study should be made before a large motor is purchased. A starting voltage requirement and preferred locked-rotor current should be stated as part of the motor specification. A motor-starting study should be made if the motor horsepower exceeds approximately 30% of the supply transformer(s) base kVA rating, if no generators are present. If generation is present, and no other sources are involved, a study should be considered whenever the motor horsepower exceeds 10–15% of the generator kVA rating, depending on actual generator characteristics. The study should also recognize contingent condition(s), i.e., the loss of a source.

It may be necessary to make a study for smaller horsepower sizes depending on the daily fluctuation of nominal voltage, voltage level, size and length of the motor feeder cable, amount of load, regulation of the supply voltage, the impedance and tap ratio of the supply transformer(s), load torque versus motor torque, and the allowable starting time. Finally, some applications may involve starting large groups of smaller motors of sufficient collective size to impact system voltage regulation during the starting interval.

A frequent problem has been failure to start when the motor coupled to its load is energized for the first time. Typically the motor appears to start smoothly, then is tripped off line by relay action before it reaches full speed. When the starting time

is prolonged enough to exceed the permissible locked rotor time, the relay can operate even though its time current curve is at all points above the motor starting curve. Some of the effects of starting a large motor are presented below.

Motor terminal voltage - During the starting, the motor terminal voltage should be maintained at approximately 80% of the rated voltage for type B motors having a standard 150% starting torque at full voltage with a constant torque load applied. A 81.6% rated voltage will develop a torque $T = 0.8162 \times 150\% = 100\%$. Also, in every case the starting time has to be evaluated for the damage limit of the motor.

Effect of motor starting on other running motors - Motors that are running normally on the system will slow down in response to the voltage drop occurring when a large motor is started. The running machines must be able to reaccelerate once the machine being started reaches the operating speed. If the voltage drop is very severe, the loading on the running machines may exceed the breakdown torque at the reduced voltage. The decelerating machines may impose heavy current demand to produce excessive voltage drop.

Heavy starting currents - In the case of design B motors, the pullout torque is 200% of the rated torque. If the motor terminal voltage falls below 71% of the rated voltage the motor may stall. This is based on the assumption that the developed torque is proportional to V. If other than design B motors are used on the system, a similar criterion can be established to evaluate re-acceleration following a motor starting.

Flicker - Power system loads such as computer equipment, power electronic equipment and sensitive control devices may be affected during motor starting. There is a wide variation in the magnitude of the voltage drop by electronic equipment. Voltage fluctuations may also cause objectionable light flicker in domestic applications. For various new electronic equipment, the allowable voltage drop data has to be obtained from the manufacturer.

Effect on control devices - The control devices are not required to pick up at voltages below 5% of the rated name plate value. The DC control devices can operate at 80% of the rated voltage. Critical control operations can therefore encounter difficulty during the motor starting period if the voltage drop is excessive. The actual drop out voltage of industrial contactors is 60% - 70% of the rated system voltage.

A brief discussion of major problems associated with starting large motors, or groups of motors, and therefore, of significance in power system design and evaluation follows.

3. Voltage dips

Probably the most widely recognized and studied effect of motor-starting is the voltage dip experienced throughout an industrial power system as a direct result of starting large motors. Available accelerating torque drops appreciably at the motor bus as voltage dips to a lower value, extending the starting interval and affecting, sometimes adversely, overall motor-starting performance. Acceptable voltage for motor-starting depends on motor and load torque characteristics. Requirements for minimum starting voltage can vary over a wide range, depending on the application. (Voltages can range from 80% or lower to 95% or higher.)

During motor-starting, the voltage level at the motor terminals should be maintained, as a minimum, at approximately 80% of rated voltage or above. This value results from examination of speed-torque characteristics of motor type (150% starting torque at full voltage) and the desire to successfully accelerate a fully loaded motor at reduced voltage (that is, torque varies with the square of the voltage $T = 0.82 \times 150\% \approx 100\%$). When other motors are affected, or when lower shaft loadings are involved, the minimum permissible voltage may be either higher or lower, respectively. The speed-torque characteristics of the starting motor along with any other affected motors and all related loads should be examined to specifically determine minimum acceptable voltage. Assuming reduced voltage permits adequate accelerating torque, it should also be verified that the longer starting interval required at reduced torque caused by a voltage dip does not result in the I^2t damage limit of the motor being exceeded. Several other problems may arise on the electrical power system due to the voltage dips caused by motor-starting.

Motors that are running normally on the system, for example, will slow down in response to the voltage dip occurring when a large motor is started. The running machines must be able to reaccelerate once the machine being started reaches operating speed. When the voltage depression caused by the starting motor is severe, the loading on the running machines may exceed their breakdown torque (at the reduced voltage), and they may decelerate significantly or even stall before the starting interval is concluded. The decelerating machines all impose heavy current demands that only compound the original distress caused by the machine that was started. The result is a “dominoing” voltage depression that can lead to the loss of all load.

The speed-torque characteristics (200% breakdown torque at full voltage) should prevent a stall, provided the motor terminal voltage does not drop below about 71% of motor nameplate voltage. This is a valid guideline to follow anytime the shaft load does not exceed 100% rated, since the developed starting torque is again proportional to the terminal voltage squared (V^2), and the available torque at 71% voltage would thus be slightly above 100%.

Other types of loads, such as electronic devices and sensitive control equipment, may be adversely affected during motor-starting. There is a wide range of variation in the amount of voltage drop that can be tolerated by static drives and computers. Voltage fluctuations may also cause objectionable fluctuations in lighting. Tolerable voltage limits should be obtained from the specific equipment manufacturers.

By industry standards, AC control devices are not required to pick-up at voltages below 85% of rated nameplate voltage, whereas DC control devices must operate dependably (i.e., pick-up) at voltages above 80% of their rating. Critical control operations may, therefore, encounter difficulty during motor-starting periods where voltage dips are excessive. A motor-starting study might be required to determine if this is a problem with thoughts to using devices rated at 110 V rather than the normal 115 V nominal devices. Contactors are required to hold-in with line voltage as low as 80% of their rating. The actual dropout voltages of contactors used in industrial applications commonly range between 60–70% of rated voltage, depending on the manufacturer. Voltages in this range, therefore, may be appropriate and are sometimes used as the criteria for the lower limit that contactors can tolerate. Depending on where lighting buses are located, with respect to large starting motors, this may be a factor requiring a motor-starting study. Table 1 summarizes some critical system voltage levels of interest when performing a motor-starting study for the purpose of evaluating the effects of voltage dips.

Table 1. Summary of representative critical system voltage levels when starting motors

Voltage drop location or problem	Minimum allowable voltage (% rated)
At terminals of starting motor	80% ^a
All terminals of other motors that must reaccelerate	71% ^a

AC contactor pick-up (by standard) (see 9.8, NEMA standards)	85%
DC contactor pick-up (by standard) (see 9.8, NEMA standards)	80%
Contactors hold-in (average of those in use)	60–70% ^b
Solid-state control devices	90% ^c
Noticeable light flicker	3% change

4. Weak source generation

Smaller power systems are usually served by limited capacity sources, which generally magnify voltage drop problems on motor-starting, especially when large motors are involved. Small systems can also have on-site generation, which causes an additional voltage drop due to the relatively higher impedance of the local generators during the (transient) motor-starting interval. The type of voltage regulator system applied with the generators can dramatically influence motor-starting as illustrated in Figure 1. A motor-starting study can be useful, even for analysing the performance of small systems. Certain digital computer programs can accurately model generator transient behaviour and exciter/regulator response under motor-starting conditions, providing meaningful results and conclusions.

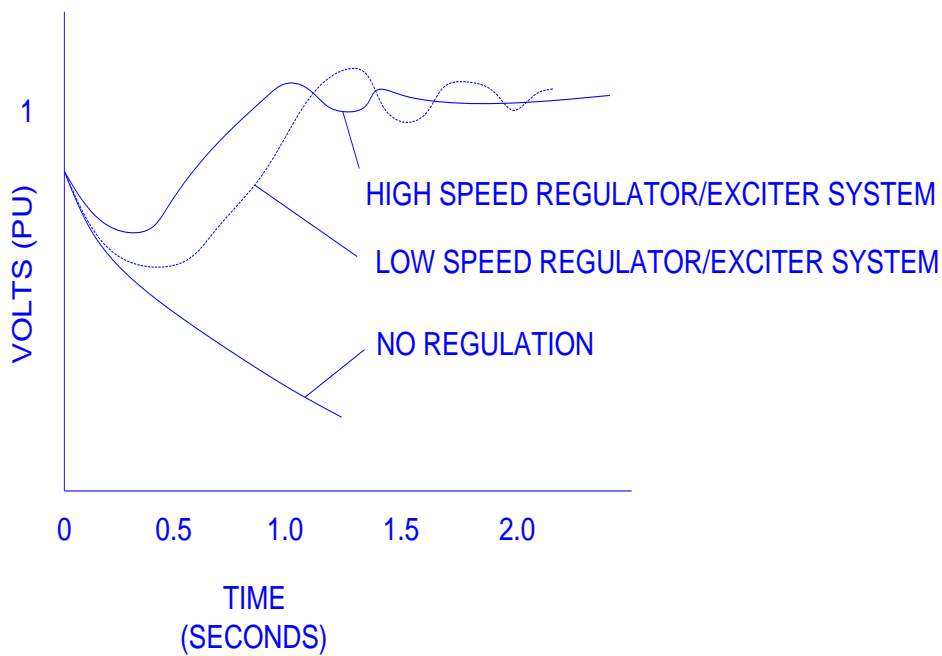

Figure 1—Typical generator terminal voltage characteristics for various exciter/regulator systems

5. Special torque requirements

Sometimes special loads must be accelerated under carefully controlled conditions without exceeding specified torque limitations of the equipment. An example of this is starting a motor connected to a load through gearing. This application requires a special period of low-torque cushioned acceleration to allow slack in the gears and couplings to be picked up without damage to the equipment. Certain computer-aided motor-starting studies allow an instant-by-instant shaft output torque tabulation for comparison to allowable torque limits of the equipment. This study can be used for selecting a motor or a starting method, or both, with optimum speed-torque characteristics for the application. The results of a detailed study are used for sizing the starting resistors for a wound rotor motor, or in analyzing rheostatic control for a starting wound rotor motor that might be used in a cushioned starting application involving mechanical gearing or a coupling system that has torque transmitting limitations.

High-inertia loads increase motor-starting time, and heating in the motor due to high currents drawn during starting can be intolerable. A computer-aided motor-starting study allows accurate values of motor current and time during acceleration to be calculated. This makes it possible to determine if thermal limits of standard motors will be exceeded for longer than normal starting intervals. Other loads have special starting torque requirements or accelerating time limits that require special high starting torque (and inrush) motors. Additionally, the starting torque of the load or process may not permit low inrush motors in situations where these motors might reduce the voltage dip caused by starting a motor having standard inrush characteristics. A simple inspection of the motor and load speed-torque curves is not sufficient to determine whether such problems exist. This is another area where the motor torque and accelerating time study can be useful.

6. Recommendations - voltage dips

A motor-starting study can expose and identify the extent of a voltage drop problem. The voltage at each bus in the system can, for example, be readily determined by a digital computer study. Equipment locations likely to experience difficulty during motor-starting can be immediately determined.

In situations where a variety of equipment voltage ratings are available, the correct rating for the application can be selected. Circuit changes, such as off-nominal tap settings for distribution transformers and larger than standard conductor-sized cable, can also be readily evaluated. On a complex power system, this type of detailed analysis is very difficult to accomplish with time-consuming hand solution methods.

Several methods of minimizing voltage dip on starting motors are based on the fact that during starting time, a motor draws an inrush current directly proportional to terminal voltage; therefore, a lower voltage causes the motor to require less current, thereby reducing the voltage dip.

Autotransformer starters are a very effective means of obtaining a reduced voltage during starting with standard taps ranging from 50% to 80% of normal rated voltage. A motor-starting study is used to select the proper voltage tap and the lower line current inrush for the electrical power system during motor start. Other special reduced-voltage starting methods include resistor or reactor starting, part-winding starting, and wye (Y)-start delta (Δ)-run motors. All are examined by an appropriate motor-starting study, and the best method for the particular application involved can be selected. In all reduced voltage starting methods, torque available for accelerating the load is a very critical consideration once bus voltage levels are judged otherwise acceptable. Only 25% torque is available, for example, with 50% of rated voltage applied at the motor terminals. Any problems associated with reduced starting torque imposed by special starting methods are automatically uncovered by a motor-starting study.

Another method of reducing high inrush currents when starting large motors is a capacitor starting system. This maintains acceptable voltage levels throughout the system. With this method, the high inductive component of normal reactive starting current is offset by the addition, during the starting period only, of capacitors to the motor bus.

This differs from the practice of applying capacitors for running motor power factor correction. A motor-starting study can provide information to allow optimum sizing of the starting capacitors and determination of the length of time the capacitor must be energized. The study can also establish whether the capacitor and motor can be switched together, or because of an excessive voltage drop that might result from the impact of capacitor transient charging current

when added to the motor inrush current, the capacitor must be energized momentarily ahead of the motor. The switching procedure can appreciably affect the cost of final installation.

Use of special starters or capacitors to minimize voltage dips can be an expensive method of maintaining voltage at acceptable levels. Where possible, off-nominal tap settings for distribution transformers are an effective, economical solution for voltage dips. By raising no-load voltage in areas of the system experiencing difficulties during motor-starting, the effect of the voltage dip can often be minimized. In combination with a load flow study, a motor-starting study can provide information to assist in selecting proper taps and ensure that light load voltages are not excessively high.

The motor-starting study can be used to prove the effectiveness of several other solutions to the voltage dip problem as well. With a wound rotor motor, differing values of resistance are inserted into the motor circuit at various times during the starting interval to reduce maximum inrush (and accordingly starting torque) to some desired value. Figure 2 shows typical speed-torque characteristic curves for a wound rotor motor.

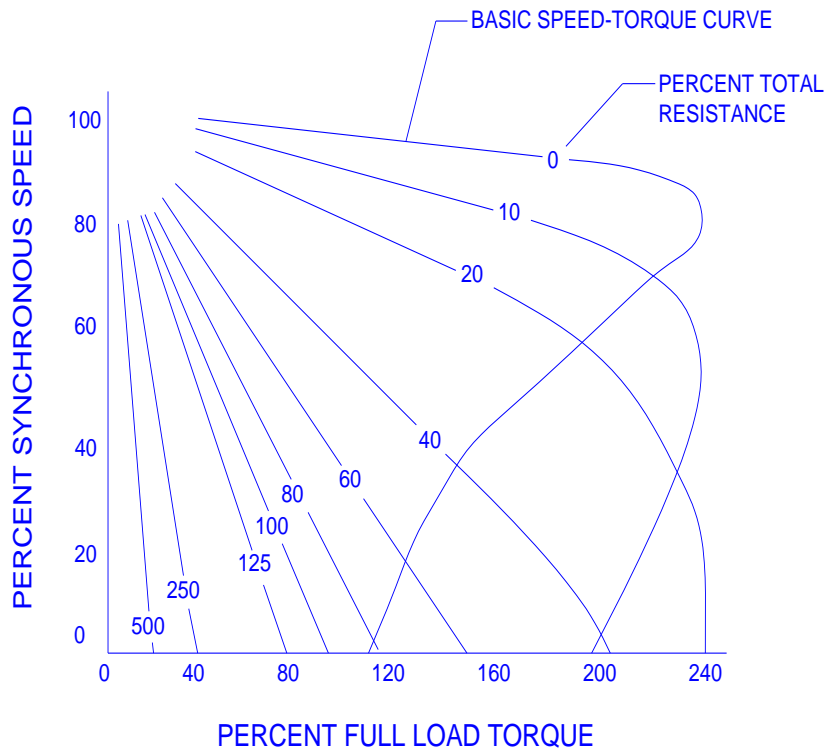

Figure 2. Typical wound rotor motor speed-torque characteristics

With appropriate switching times (dependent on motor speed) of resistance values, practically any desired speed-torque (starting) characteristic can be obtained. A motor-starting study aids in choosing optimum current and torque values for a wound rotor motor application whether resistances are switched in steps by timing relays or continuously adjusted values obtained through a liquid rheostat feedback starting control.

For small loads, voltage stabilizers are sometimes used. These devices provide essentially instantaneous response to voltage fluctuations by “stabilizing” line voltage variations of as great as $\pm 15\%$ to within $\pm 1\%$ at the load. The cost and limited loading capability of these devices, however, have restricted their use mostly to controlling circuit power supply applications.

Special inrush motors can be purchased for a relatively small price increase over standard motors. These motors maintain nearly the same speed-torque characteristics as standard machines, but the inrush current is limited (usually to about 4.6 times full load current compared with 6 times full load current for a standard motor).

7. Starting methods

If a normal supply voltage is applied to an induction motor at standstill, the starting current will be on the order of 6 times the rated current. The starting torque is also limited and can be improved by inserting a resistance in the rotor circuit in the case of slip ring motors. However, there is need to limit the inrush current during the starting. There are several starting methods used for large motors.

Series impedance starting - A resistance or reactance can be used in series with the motor winding during starting. Then by using a contactor, the series impedance can be short circuited. If a series reactance is used in the starting, the power factor will be poor and produce significant disturbance in the line. If a series resistance is used, then the power factor will be better, but the losses in the resistance will be high. Standard reactors are available to limit the starting voltages at the motor terminal to 50%, 75% and 90% of the terminal voltage at the instant of starting. When starting with a series reactance the kVA drawn from the supply is reduced directly proportional to the applied voltage and the motor torque is reduced proportional to the square of the voltage. If x is the fraction of

the voltage reduced by the series impedance, then the starting current and the torque are given by:

$$I_{ST} = xI_{SC}$$

$$T_{ST} = x^2T_{SC}$$

$$\frac{T_{ST}}{T_f} = \left(\frac{I_{ST}}{I_f}\right)^2 sf = \left(\frac{xI_{SC}}{I_f}\right)^2 = x^2 \left(\frac{I_{SC}}{I_f}\right)^2 sf$$

Using the above relations, the starting current and the starting torque can be evaluated if the full load current, short circuit current, slip at the rated load, the full load torque and the fraction of the voltage applied are known.

Auto-transformer starting - In this method, a reduced voltage is applied to the motor using an auto-transformer and the voltage is increased to the nominal value after the starting. With auto-transformer starting, the acceleration time of the motor is longer, if a constant torque is produced during the starting. Further, the reactance of the auto-transformer is in parallel with the motor. In the case of an autotransformer starting, if a tapping of transformation x is used then the phase voltage across the motor is $(x VA/3)$.

Wye/delta starter - For small and medium size motors, the wye/delta starter can be used. The stator winding is connected in wye during the starting and in delta for the running. This starter is the simplest form of mechanical equipment and is suitable for small and medium size motors.

Shunt capacitors to reduce the starting current - The shunt capacitors can be used across the motor terminals to reduce the reactive component of the current during the starting. Experimental results on a 2-hp, 220 V, 7 A, 3,600 rpm, wye connected, three-phase induction motor show significant reduction in the line currents. The shunt capacitors can cause ferroresonance when interacting with the magnetic circuit of the induction motors. Therefore, the shunt capacitors have to be switched off as soon as the starting is completed. However, switching off the shunt capacitors requires further consideration from the transient recovery voltage point of view.

8. Analysing starting requirements

A speed-torque and accelerating time study often in conjunction with the previously discussed voltage dip study permits a means of exploring a variety of possible motor speed-torque characteristics. This type of motor-starting study also confirms that starting times are within acceptable limits. The accelerating time study assists in establishing the necessary thermal damage characteristics of motors or verifies that machines with locked-rotor protection supervised by speed switches will not experience nuisance tripping on starting.

The speed-torque/accelerating time motor-starting study is also used to verify that special motor torque and/or inrush characteristics specified for motors to be applied on the system will produce the desired results. Mechanical equipment requirements and special ratings necessary for motor-starting auxiliary equipment are based on information developed from a motor-starting study.

9. Types of studies

From the previous discussion, it is apparent that, depending on the factors of concern in any specific motor-starting situation, more than one type of motor-starting study can be required.

10. The voltage drop snapshot

One method of examining the effect of voltage dip during motor-starting is to ensure the maximum instantaneous drop that occurs leaves bus voltages at acceptable levels throughout the system. This is done by examining the power system that corresponds to the worst-case voltage. Through appropriate system modelling, this study can be performed by various calculating methods using the digital computer. The so-called voltage drop snapshot study is useful only for finding system voltages. Except for the recognition of generator transient impedances when appropriate, machine inertias, load characteristics, and other transient effects are usually ignored. This type of study, while certainly an approximation, is often sufficient for many applications.

11.The detailed voltage profile

This type of study allows a more exact examination of the voltage drop situation. Regulator response, exciter operation, and, sometimes, governor action are modelled to accurately represent transient behaviour of local generators. This type of study is similar to a simplified transient stability analysis and can be considered a series of voltage snapshots throughout the motor-starting interval including the moment of minimum or worst-case voltage.

12.The speed-torque and acceleration time analysis

Perhaps the most exacting analysis for motor-starting conditions is the detailed speed-torque analysis. Similar to a transient stability study (some can also be used to accurately investigate motor-starting), speed-torque analysis provides electrical and accelerating torque calculations for specified time intervals during the motor-starting period. Motor slip, load and motor torques, terminal voltage magnitude and angle, and the complex value of motor current drawn are values to be examined at time zero and at the end of each time interval.

Under certain circumstances, even across-the-line starting, the motor may not be able to break away from standstill, or it may stall at some speed before acceleration is complete. A speed-torque analysis, especially when performed using a computer program, and possibly in combination with one or more previously discussed studies, can predict these problem areas and allow corrections to be made before difficulties arise.

When special starting techniques are necessary, such as autotransformer reduced voltage starting, speed-torque analysis can account for the autotransformer magnetizing current and it can determine the optimum time to switch the transformer out of the circuit. The starting performance of wound rotor motors is examined through this type of study.

13.Effect of Initial Conditions

The initial conditions of power system operation have influence on the voltage drops calculated. The initial conditions may be due to the nature of the existing load in adjacent buses, running motors and initial bus voltages.

Type of load - The presence of constant impedance loads such as lights, resistors, reactors and lightly loaded motors does not have significant influence on the calculated voltage drop. Also, the constant current loads have a combination of the above loads plus loaded motors do not affect the voltage drop calculations. However, fully loaded motors will have certain influence on the calculated voltage drops.

Loaded motors at unity power factor - If there is large number of fully loaded induction motors or synchronous motors at unity power factor, then the operation of these motors will have significant effect on the calculated voltage drop. An approximate mathematical relation can be presented for the modified voltage drop (V_m) as:

$$V_m = \left[\frac{0.65 \cdot \text{Initial kVA}}{\text{Generator kVA}} \right] \cdot \text{Voltage drop with no initial load}$$

The application of this must be done carefully, if the calculated voltage drop is over 30%. Under such conditions, the running motors will stall drawing significant current and additional voltage drop. Also, the contactor may drop isolating the motors from service.

Leading power factor motor loads - In some cases synchronous motors may be running with leading power factor. In such cases, the reactive power supplied from the source produces a smaller voltage drop. The mathematical relation representing such a condition is given by:

$$\% \text{Voltage Drop} = \frac{100(\text{Motor Short Circuit kVA} - \text{Leading PF kVA})}{\text{Motor Short Circuit kVA} + \text{kVAsc} - \text{Leading PF kVA}}$$

Effect of initial bus voltage - In some cases it is possible that the actual bus voltage is less than the expected 1.0 P.U voltage. If the source voltage is always on the higher side of the nominal voltage, then the available terminal voltage at the motor will be higher.

14. Calculation of acceleration time

The acceleration time of the motor shaft during starting can be calculated by solving the equation of motion given by:

$$dt = J \frac{d\omega}{(T - T_1)}$$

The time required to accelerate from the speed ω_1 to ω_2 is:

$$t = \int_{\omega_1}^{\omega_2} \frac{J d\omega}{(T - T_1)}$$

In order to find the value of this integral, it is necessary to know the motor torque (T) and the load torque (T₁) as a function of speed. In the simplest case, when the motor torque and the load torque are constant, then:

$$\Delta t = J \frac{(\omega_2 - \omega_1)}{(T - T_1)}$$

$$\omega = \frac{2\pi N}{60}$$

The total inertia J is represented by W_k^2 . Taking that into consideration above equation can be simplified.

$$\Delta t = \frac{W_k^2 \Delta N}{308(T - T_1)}$$

During the starting of a motor, the terminal voltage will drop and the corresponding torque will be less. Therefore, suitable correction factor has to be applied to account for the torque reduction. The motor terminal voltage and the accelerating torque are given by:

$$\text{Motor terminal voltage} = V \left[1 - \frac{\text{Input kVA}}{\text{Input kVA} + \text{KVAsc}} \right]$$

Where KVAsc is the short circuit rating of the source. The net motor torque (T_r) can be calculated by:

$$T_r = T [\text{V in per unit}]^2$$

The net accelerating torque is the difference between the resultant motor torque and the load torque. In order to improve the accuracy of the calculated

acceleration time, a reduced time step is required. The calculation procedure is explained using an example.

Example - Consider a 500-hp, 460 V, 1170 rpm, 3 phase induction motor for an application with torque speed characteristics as shown in table below. The combined inertia of the motor shaft and the load is 3,500 lbs-ft . The short circuit kVA of the system is 35,000 kVA. The input to the motor at rated load is 450 kVA. Calculate the acceleration time in seconds using a step-by-step approach.

Speed Increment	Motor Torque (%)	Load Torque (%)	% kVA
0 to 20%	84	5	550
20 to 40%	93	8	540
40 to 60%	120	20	525
60 to 80%	175	30	480
80 to 100%	167	45	350

One iteration of calculation is shown below and the table of results is calculated using a spread sheet.

Voltage at the motor terminal before stating =105%
 Speed increment =20%
 Motor input kVA (5.5 x 450 kVA) =2475 kVA

$$\text{Motor terminal voltage} = 105 \left[1 - \frac{2475}{2475 + 35000} \right] = 98.07\%$$

Motor full load torque (5250 x 500 hp/1170 rpm)=2239.3 lb-ft
 Net torque (84% - 5%) =79%
 Net torque (0.79 x 2239.3 lb-ft) =1769.1 lb-ft

$$T_r = T_t [V \text{ in per unit}]^2 = 1769.1 [0.9807]^2 = 1701.5 \text{ lb-ft}$$

$$\Delta t = \frac{W_k^2 \Delta N}{308(T - T_1)} = \frac{3500 \cdot 1170 \cdot 0.2}{308 \cdot 1759.1} = 1.5 \text{ second}$$

This calculation can be repeated and the step-by-step results are presented in a table. The total delta t's are added to get the total starting time of the motor.

Speed Change (%)	% kVA	kVA	% of Motor Voltage	FV Tor. (Lb-ft.)	Motor Tor. (%)	Load Tor. (%)	Net Tor. (%)	Net Tor. (Lb-ft.)	Δt (s)
0-20	550	2475	98.07	100	84	5	79	1,769.06	1.50
20-40	540	2430	98.18	110	93	8	85	1,903.42	1.40
40-60	525	23625	98.36	140	120	20	100	2,239.32	1.19
60-80	480	2160	98.90	200	175	30	145	3,247.01	0.82
80-100	350	1575	100.47	180	167	45	122	2,731.97	0.97

15. Motor starting with limited-capacity generators

In smaller power systems with one or two generators, the source impedance is significant and a motor starting will result in the drop in the speed of the generator. Usually, the generators are equipped with automatic voltage regulators and governors. The motor starting performance depends on the type of voltage regulator. With normal regulators there will be some voltage drop during the motor starting. With high-speed regulators, the performance will be better and with extra high speed regulation will be still better. It is necessary to perform motor starting studies modeling both the generator and motor to be started.

16. Adaptations

A particular application can require a slight modification of any of the above studies to be of greatest usefulness. Often, combinations of several types of studies described are required to adequately evaluate system motor-starting problems.

17. Data requirements - basic information

Since other loads on the system during motor-starting affect the voltage available at the motor terminals, the information necessary for a load flow or short-circuit study is essentially the same as that required for a motor-starting study. This information is summarized below.

- Utility and generator impedances. These values are extremely significant and should be as accurate as possible. Generally, they are obtained from local utility representatives and generator manufacturers. When representing the utility impedance, it should be based on the minimum capacity of the utility system in order to yield the most pessimistic results insofar as voltage drop problems are concerned. This is in direct opposition to the approach normally used for a short-circuit analysis discussed. Where exact generator data cannot be obtained, typical impedance values are available.
- Transformers. Manufacturers' impedance information should be obtained where possible, especially for large units (that is, 5000 kVA and larger). Standard impedances can usually be used with little error for smaller units.
- Other components. System elements (such as cables) should be specified as to the number and size of conductor, conductor material, and whether magnetic duct or armor is used. All system elements should be supplied with R and X values so an equivalent system impedance can be calculated.
- Load characteristics. System loads should be detailed including type (constant current, constant impedance, or constant kVA), power factor, and load factor, if any. Exact inrush (starting) characteristics should also be given for the motor to be started.
- Machine and load data. Along with the aforementioned basic information, which is required for a voltage drop type of motor-starting analysis, several other items are also required for the detailed speed-torque and accelerating time analysis. These include the Wk^2 of the motor and load (with the Wk^2 of the mechanical coupling or any gearing included), and speed-torque characteristics of both the motor and load. Typical speed-torque curves are shown in Figure 3.

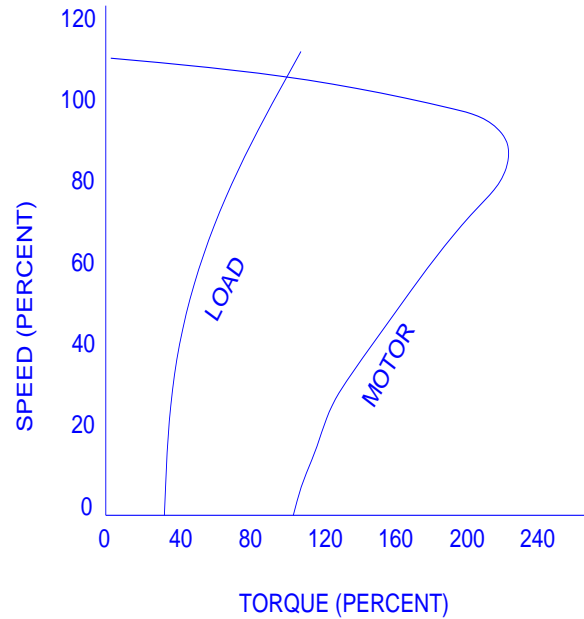

Figure 3. Typical motor and load speed-torque characteristics

For additional accuracy, speed versus current and speed versus power factor characteristics should be given for as exact a model as possible for the motor during starting. For some programs, constants for the motor equivalent circuit given in Figure 4 can be either required input information or typical default values. This data must be obtained from the manufacturer since values are critical. Exciter/regulator data should also be obtained from the manufacturer for studies involving locally connected generators.

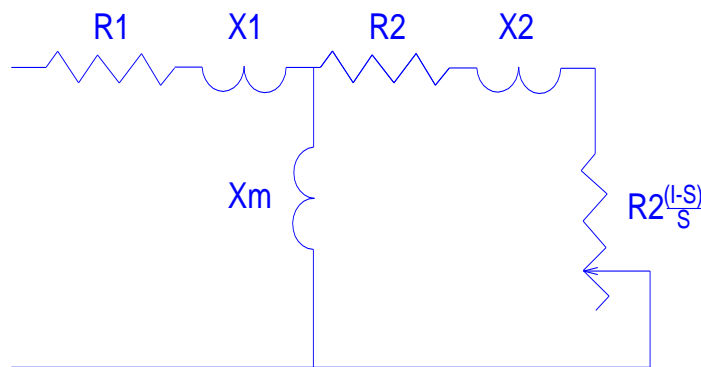

Figure 4. Simplified equivalent circuit for a motor on starting

When special motor applications are involved like high starting torque or low starting current, motor manufacturers may use special “deep bar” or double

squirrel cage motor rotor designs. These designs can be represented either by their torque/speed curves, or by an equivalent electrical circuit model with two (or more) parallel rotor branches represented. This increases the complexity of the equivalent circuit and the corresponding mathematical solution beyond that of the more simplified single rotor model depicted in Figure 4.

18.Simplifying assumptions

Besides using standard impedance values for transformers and cables, it is often necessary to use typical or assumed values for other variables when making motor-starting voltage drop calculations. This is particularly true when calculations are for evaluating a preliminary design and exact motor and load characteristics are unknown. Some common assumptions used in the absence of more precise data follow:

a) Horsepower to kVA conversion. A reasonable assumption is 1 HP equals 1 kVA. For synchronous motors with 0.8 leading, running power factor, and induction motors, it can easily be seen from the following equation:

$$HP = \frac{kVA (PF)(EFF)}{0.746}$$

The ratio of 0.746 to efficiency times the power factor approaches unity for most motors given the 1 HP/kVA approximation. Therefore, for synchronous motors operating at 1.0 PF, a reasonable assumption is 1 HP equals 0.8 kVA.

b) Inrush current. Usually, a conservative multiplier for motor-starting inrush currents is obtained by assuming the motor to have a code G characteristic with locked-rotor current equal to approximately 6 times the full load current with full voltage applied at motor terminals. A conservative and acceptably accurate method for determining the locked rotor current to full load running current ratio is to use the reciprocal of the motor's subtransient reactance when this characteristic is known.

c) Starting power factor. The power factor of a motor during starting determines the amount of reactive current that is drawn from the system, and thus, to a large extent, the maximum voltage drop. Typical data suggest the following:
Motors under 1000 HP, PF = 0.20

Motors 1000 HP and over, PF = 0.15

The starting power factor can also be determined by knowing the short-circuit X/R ratio of the machine. Thus:

Starting power factor = $\cos(\arctan X/R)$

If a machine has an X''_d equal to 0.17 p.u. impedance on its own machine base, and a short-circuit X/R ratio of 5.0, then its locked rotor current ratio would be 5.9 and associated starting power factor would be 20%, or 0.2 p.u.

These power factor values are only rules of thumb for larger, integral horsepower-sized “standard” design motors. Actual motor power factors may vary dramatically from these values, especially for small horsepower size machines or any size special-purpose motor.

For example, the starting power factor of a “standard” 5 horsepower motor may be 0.6 or larger, while the starting power factor of a high starting torque, fractional horsepower motor may be 0.85 or more. Wherever large numbers of small motors or any number of special torque characteristic motors are connected to a system or circuit, actual power factors should always be confirmed for purposes of performing accurate motor-starting calculations.

19.Solution procedures and examples

Regardless of the type of study required, a basic voltage drop calculation is always involved. When voltage drop is the only concern, the end product is this calculation when all system impedances are at maximum value and all voltage sources are at minimum expected level. In a more complex motor speed-torque analysis and accelerating time study, several voltage drop calculations are required. These are performed at regular time intervals following the initial impact of the motor-starting event and take into account variations in system impedances and voltage sources.

Results of each iterative voltage drop calculation are used to calculate output torque, which is dependent on the voltage at machine terminals and motor speed. Since the interval of motor-starting usually ranges from a few seconds to 10 or more seconds, effects of generator voltage regulator and governor action are evident, sometimes along with transformer tap control depending on control settings. Certain types of motor-starting studies account for generator voltage

regulator action, while a transient stability study is usually required in cases where other transient effects are considered important. A summary of fundamental equations used in various types of motor-starting studies follows in this subclause, along with examples illustrating applications of fundamental equations to actual problems

20. The mathematical relationships

There are basically three ways to solve for bus voltages realized throughout the system on motor-starting.

- Impedance method. This method involves reduction of the system to a simple voltage divider network where voltage at any point (bus) in a circuit is found by taking known voltage (source bus) times the ratio of impedance to the point in question over total circuit impedance. For the circuit of Figure 5,

$$V = E \frac{X_1}{X_1 + X_2}$$

or, more generally,

$$V = E \frac{Z_1}{Z_1 + Z_2}$$

The effect of adding a large capacitor bank at the motor bus is seen by the above expression for V. The addition of negative vars causes X1 or Z1 to become larger in both numerator and denominator, so bus voltage V is increased and approaches 1.0 per unit as the limiting improvement.

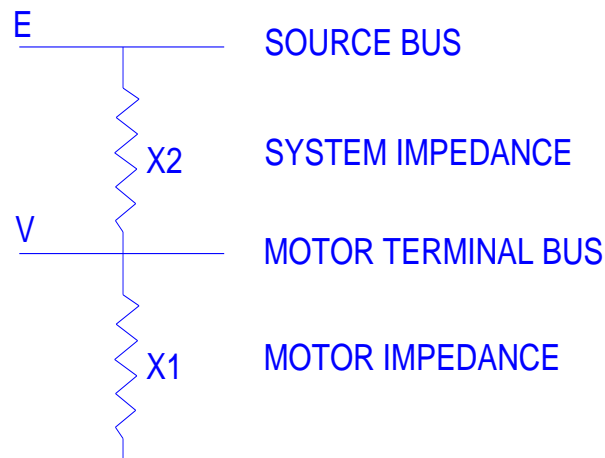

Figure 5. Simplified impedance diagram

Locked-rotor impedance for three-phase motor is simply

$$Z_{LR} = E \frac{\text{rated voltage } L-L}{\sqrt{3}LRA} (\Omega)$$

where

LRA is the locked-rotor current at rated voltage

This value in per unit is equal to the inverse of the inrush multiplier on the motor rated kVA base:

$$Z_{LR} = E \frac{1}{\left(\frac{LRA}{FLA}\right)} (\text{per unit})$$

Since a starting motor is accurately represented as constant impedance, the impedance method is a very convenient and acceptable means of calculating system bus voltages during motor-starting. Validity of the impedance method can be seen and is usually used for working hand calculations. Where other than simple radial systems are involved, the digital computer greatly aids in obtaining necessary network reduction. To obtain results with reasonable accuracy, however, various system impedance elements must be represented as complex quantities rather than as simple reactance.

- Current method. For any bus in the system represented in Figure 6 and Figure 7, the basic equations for the current method are as follows:

$$I_{\text{per unit}} = \frac{MVA_{\text{load}}}{MVA_{\text{base}}} \text{ at 1.0 per unit voltage}$$

$$V_{\text{drop}} = I_{\text{per unit}} \times Z_{\text{per unit}}$$

$$V_{\text{drop}} = I_{\text{source}} - V_{\text{drop}}$$

The quantities involved should be expressed in complex form for greatest accuracy, although reasonable results can be obtained by using magnitudes only for first-order approximations.

The disadvantage to this method is that, since all loads are not of constant current type, the current to each load varies as voltage changes. An iterative type solution procedure is therefore necessary to solve for the ultimate voltage at every bus, and such tedious computations are readily handled by a digital computer. Load flow solution method. From the way loads and other system elements are portrayed in Figure 6 and Figure 7, it appears that bus voltages and the voltage

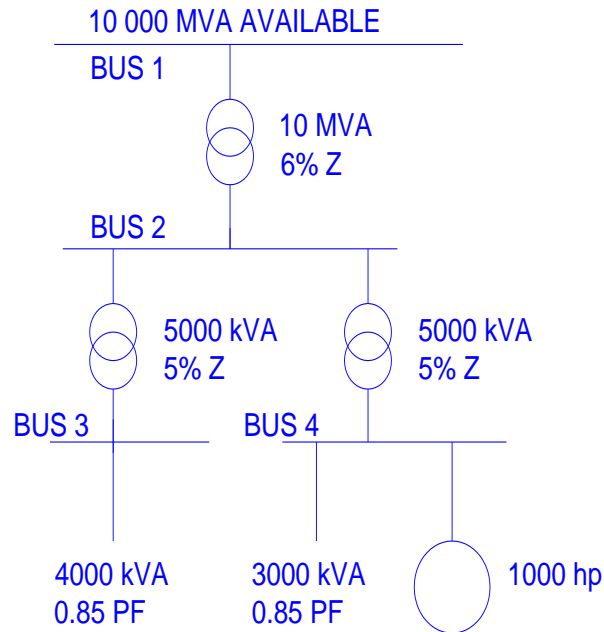

Figure 6. Typical single-line diagram

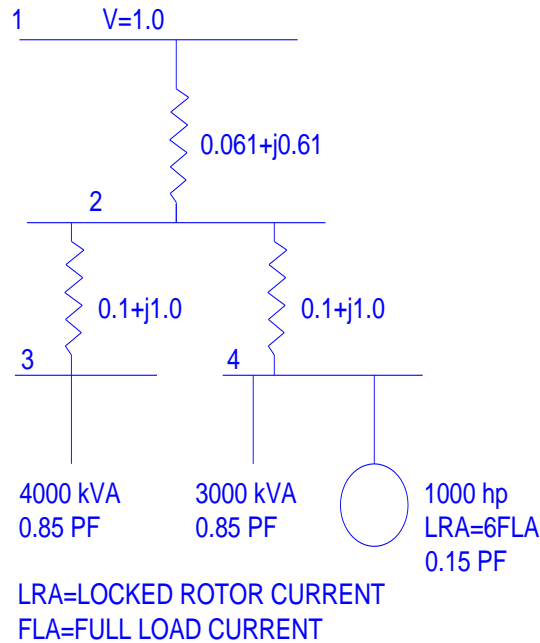

Figure 7. Impedance diagram for system in Figure 6

dip could be determined by a conventional load flow program. This is true. By modelling the starting motor as a constant impedance load, the load flow calculations yield the bus voltages during starting. The basic equations involved in this process are repeated here.

$$I_k = \frac{P_k - jQ_k}{V_k^*} - Y_k V_k$$

$$V_k = V_{ref} + \sum_{i=1}^n Z_{ki} \left(\frac{P_i - jQ_i}{V_i} - Y_i V_i \right)$$

where

I_k is the current in the k th branch of any network P_k , Q_k is the real and reactive powers representative of the loads at the k th bus V_k is the voltage at the k th bus Y_k is the admittance to ground of bus k is the voltage of the swing or slack bus V_{ref} n is the number of buses in the network is the system impedance between the k th and i th buses Z_{ki} . The load flow solution to the motor-starting problem is very precise for finding bus voltages at the instant of maximum voltage drop. It is apparent from the expressions for I_k and V_k that this solution method is ideally

suited for the digital computer any time the system involves more than two or three buses.

21. Other factors

Unless steady-state conditions exist, all of the above solution methods are valid for one particular instant and provide the single snapshot of system bus voltages as mentioned earlier. For steady-state conditions, it is assumed that generator voltage regulators have had time to increase field excitation sufficiently to maintain the desired generator terminal voltage. Accordingly, the presence of the internal impedance of any local generators connected to the system is ignored. During motor-starting, however, the influence of machine transient behaviour becomes important. To model the effect of a close-connected generator on the maximum voltage drop during motor-starting requires inclusion of generator transient reactance in series with other source reactance. In general, use of the transient reactance as the representation for the machine results in calculated bus voltages and, accordingly, voltage drops that are reasonably accurate and conservative, even for exceptionally slow-speed regulator systems.

Assuming, for example, that bus 1 in the system shown in Figure 7 is at the line terminals of a 12 MVA generator rather than being an infinite source ahead of a constant impedance utility system, the transient impedance of the generator would be added to the system. The resulting impedance diagram is shown in Figure 8. A new bus 99 is created. Voltage at this new bus is frequently referred to as voltage behind the transient reactance. It is actually the internal machine transient driving voltage.

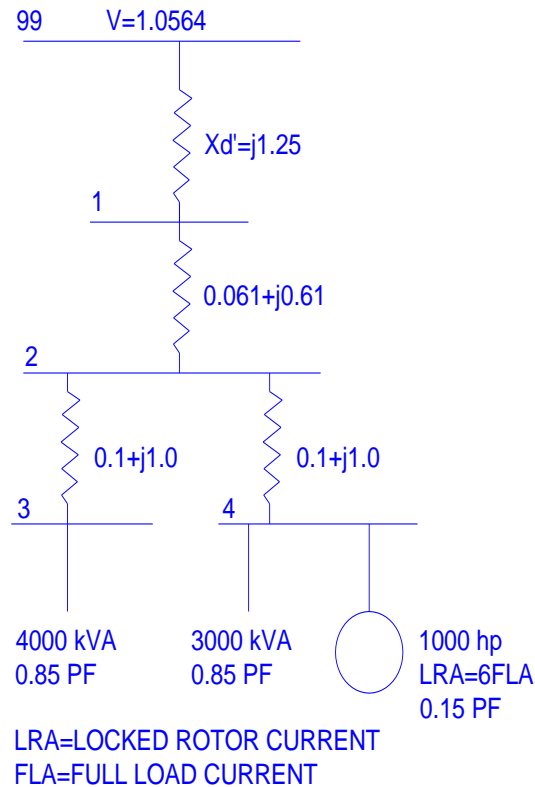

Figure 8. Revised impedance diagram showing transient reactance of generator

When the steady-state operating voltage is 1.0 per unit, the internal machine transient driving voltage can be considered the voltage that must be present ahead of the generator transient reactance with the terminal voltage maintained at 1.0 per unit (within exciter tolerances) during steady-state conditions while supplying power to the other loads on the system. The transient driving voltage V is calculated as follows:

$$V = V_{terminal} + (jX'_d)I_{load}$$

$$= 1 + (jX'_d)(I_{load})$$

Where

$$V_{terminal} = 1.0 \text{ per unit}$$

$$I_{load} = \frac{MVA_{load}}{MVA_{base}} \text{ per unit}$$

Treatment of a locally connected generator is equally applicable to all three solution methods described previously. Such an approach cannot give any detail

regarding the response of the generator voltage regulator or changes in machine characteristics with time. For a more detailed solution that considers time-dependent effects of machine impedance and voltage regulator action, the appropriate impedance and voltage terms in each expression must be continuously altered to accurately reflect changes that occur in the circuit. This procedure is also applicable to any solution methods considered. Figure 9 shows a simplified representation of the machine parameters that must be repeatedly modified to obtain the correct solution.

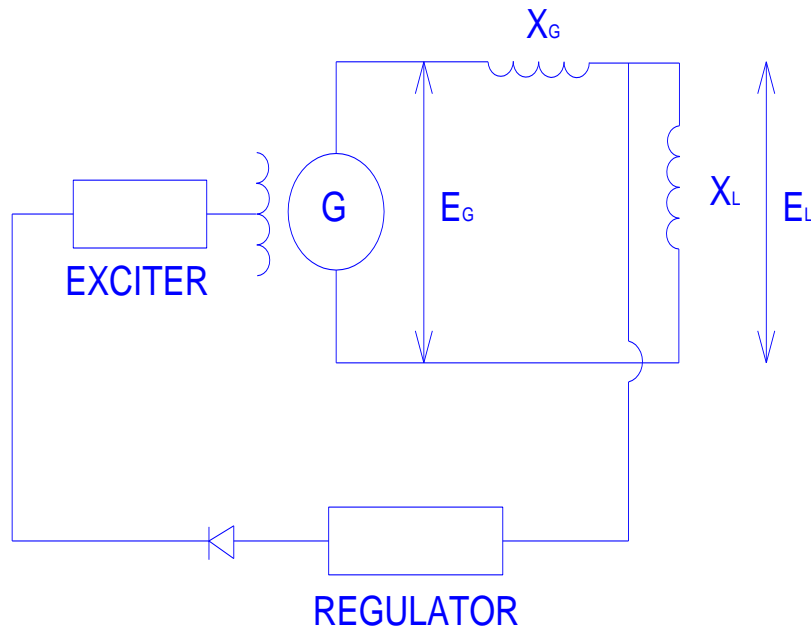

Figure 9. Simplified representation of generator exciter/regulator system

Some type of reduced voltage starting is often used to minimize motor inrush current and thus reduce total voltage drop, when the associated reduction in torque accompanying this starting method is permissible.

Representation used for the motor in any solution method for calculating voltage drop must be modified to reflect the lower inrush current. If autotransformer reduced voltage starting is used, motor inrush will be reduced by the appropriate factor from Table 2. If, for example, normal inrush is 6 times full load current and an 80% tap autotransformer starter is applied, the actual inrush multiplier used for determining the appropriate motor representation in the calculations is $(6)(0.64) = 4.2 \times$ full load current. Resistor or reactor starting limits the line starting current by the same amount as motor terminal voltage is reduced (that is, 65% of applied bus voltage gives 65% of normal line starting current).

Autotransformer tap (% line voltage)	Line starting current (% normal at full voltage)
50	25
65	42
80	64

Table 2. Autotransformer line starting current

Wye (Y)-start, delta (Δ)-run starting delivers 33% of normal starting line current with full voltage at the motor terminals. The starting current at any other voltage is, correspondingly, reduced by the same amount. Part winding starting allows 60% of normal starting line current at full voltage and reduces inrush accordingly at other voltages.

Adjustable speed drives generally provide suitable controls for limiting inrush currents associated with motor-starting. For this type of apparatus the inrush associated with motor-starting is almost always significantly less than for a motor-starting across the line. For purposes of motor-starting analysis, the starting current for the drive and motor simply can be modeled as the maximum imposed by the drive upon the system.

When a detailed motor speed-torque and accelerating time analysis is required, the following equations found in many texts apply. The equations in general apply to both induction and synchronous motors, since the latter behave almost exactly as do induction machines during the starting period.

$$T \propto V^2$$

$$T = I_0 \alpha$$

$$I_0 = \frac{Wk^2}{2g} \text{ (lb} \cdot \text{ft} \cdot \text{s}^2)$$

$$\omega^2 = \omega_0^2 + 2\alpha(\theta - \theta_0) \frac{r}{s}$$

$$\Delta\theta = \omega_0 t + \frac{1}{2} \alpha t^2 \text{ (r)}$$

$$\alpha = \frac{T_n 2g}{Wk^2} \left(\frac{r}{s^2} \right)$$

A simplified approximation for starting time is also available:

$$t(s) = \frac{Wk^2 \left(\frac{r}{min_1} - \frac{r}{min_2} \right) (2\pi)}{60gT_n}$$

where

T is the average motor shaft output torque

V is the motor terminal voltage

IO is the moment of inertia

g is the acceleration due to gravity

ω is the angular velocity

α is the angular acceleration

t is the time in seconds to accelerate

Tn is the net average accelerating torque between rev/min1 and rev/min2

θ is the electrical angle in degrees

Wk2 is the inertia

Substituting for g and rearranging yields:

$$t(s) = \frac{Wk^2 \left(\frac{r}{min_1} - \frac{r}{min_2} \right)}{308T_n}$$

The basic equation for use with the equivalent circuit of Figure 4 is as follows:

$$T = \frac{q_1 V^2 \left(\frac{r_2}{s} \right)}{\omega_s \left(r_1 + \frac{r_2}{s} \right)^2 + (X_1 + X_2)^2}$$

where

T is the instantaneous torque

ω_s is the angular velocity at synchronous speed

$(r_1 + jX_1)$ is the stator equivalent impedance

$(r_2 / s + jX_2)$ is the rotor equivalent impedance

q1 is the number of stator phases (3 for a 3 ϕ machine)

V is the motor terminal voltage

22. The simple voltage drop determination

To illustrate this type of computer analysis, the system of Figure 6 will again be considered. It is assumed that bus 1 is connected to the terminals of a 12 MVA generator having 15% transient reactance (1.25 per unit on a 100 MVA base). Prior to starting, when steady-state load conditions exist, the impedance diagram of Figure 7 applies with the motor off-line. The impedance diagram of Figure 8 applies when the 1000 HP motor on bus 4 is started.

Bus 99 in Figure 8 has been assigned a voltage of 1.056 per unit. This value can be confirmed using the expression for the internal machine transient driving voltage V given in 9.6.2 with appropriate substitutions as follows:

$$\begin{aligned} V &= (1.0 + j0.0) + (j1.25)(0.060114 - j0.042985) \\ &= (1.0 + 1.0537) + (j0.07514) \\ &= 1.0564 \text{ p.u. voltage } \angle 4.08^\circ \end{aligned}$$

where values for the current through the $X'd$ element are expressed on a 100 MVA base and correspond to those that exist at steady state prior to motor-starting with bus 1 operating at 1.0 p.u. voltage. All system loads are on-line, except the 1000 HP motor. The two non-motor loads are modeled as constant power type loads. The two loads combined require $5.955 + j3.687$ MVA.

Therefore, the losses in the system, including those through the generator are equal to $0.056 + j0.612$ MVA. With these values of power flowing during steady-state, prior to motor-starting, the swing bus is at the required value of 1.0 p.u. voltage. The voltage drop at the motor bus, without the motor on line is 4.89%, resulting in an operating voltage prior to starting of 0.951 p.u. voltage.

For convenience, the voltage angle associated with the generator (or swing) bus is assumed to be zero, which results in the corresponding shift for all other bus voltages. Since the transformers are assumed to be connected delta-delta, the angular phase shifts indicated are due to the voltage drops alone.

Although this voltage is very close to the 0.80 p.u. value required to start many motors, it is well below the 0.85 p.u. criterion established earlier for proper operation of ac control devices that are connected at most motor-starting buses. Further examination of this problem with the calculation software would show

that when the motor-starting interval is over, and the motor is operational, the voltage at the motor bus recovers to 0.92 p.u. A second study could be easily performed to explore the effects of increasing the motor-starting bus voltage, by adjusting the transformer tap settings.

23. Time-dependent bus voltages

The load flow solution method for examining effects of motor-starting allows a look at the voltage on the various system buses at a single point in time. A more exact approach is to model generator transient impedance characteristics and voltage sources closer to give results for a number of points in time following the motor-starting event. The digital computer is used to solve several simultaneous equations that describe the voltage of each bus in a system at time zero and at the end of successive time intervals.

The system shown in Figure 12 contains certain assumptions, which include the following:

- Circuit losses are negligible—reactances only used in calculations.
- Initial load is constant kVA type.
- Motor-starting load is constant impedance type.
- Motor-starting power factor is in the range of 0 to 0.25.
- Mechanical effects, such as governor response, prime mover speed changes, and inertia constants, are negligible.

Variations in exciter field voltage (EFV) over each time interval considered are used to calculate system bus voltages at the end of these same intervals. A single main machine field circuit time constant is used in the generator representation, and Fromlich's approximation for saturation effects is used when the voltage behind the generator leakage reactance indicates that saturation has been reached. The tabulated output stops just short of full recovery since a more complex model is necessary to represent overshoot, oscillation, etc., beyond this point. Of primary concern in this type of study is the maximum voltage dip and the length of time to voltage recovery as a function of generator behavior and voltage regulator performance.

24. The speed-torque and motor-accelerating time analysis

A simplified sample problem is presented for solution by hand. In this way, it is possible to appreciate how the digital computer aids in solving the more complex problems. The following information applies to the system shown in Figure 10.

Motor hp = 1000 (induction)

Motor r/min = 1800

Motor Wk² = 270 lbft²

Load Wk² = 810 lbft²

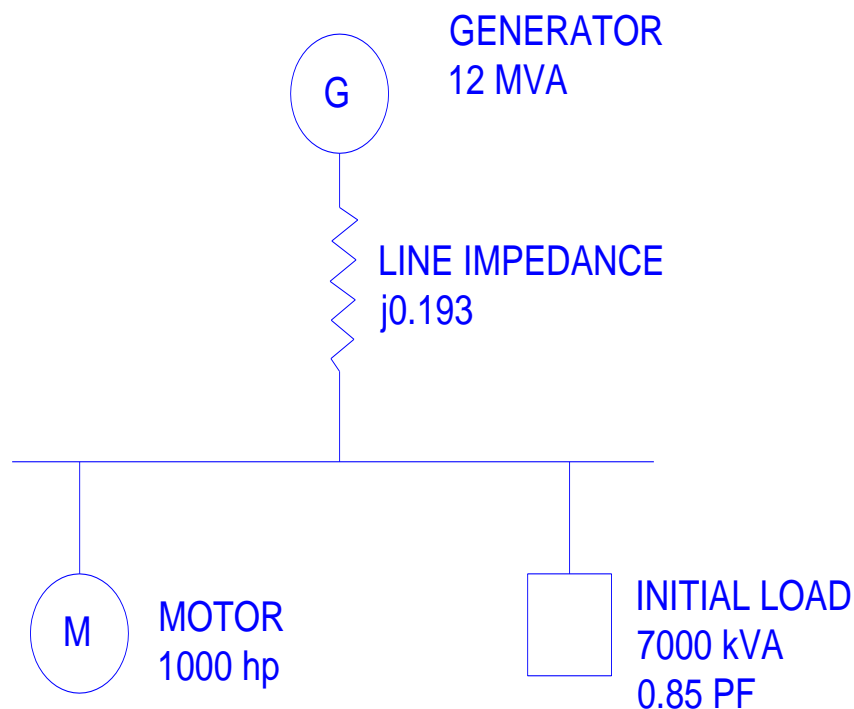

Figure 10. Simplified system model for generator representation during motor starting

Assuming Figure 3 describes the speed-torque characteristic of the motor and the load, it is possible to find an average value for accelerating torque over the time interval defined by each speed change. This can be done graphically for hand calculations.

Applying the simplified formula for starting time provided earlier,

$$t_{0-25} = \frac{(270 + 810)(450 - 0)}{(308)(2260.4)} = 0.6981 \text{ s}$$

$$t_{25-50} = \frac{(1080)(900 - 450)}{(308)(2916.7)} = 0.541 \text{ s}$$

$$t_{50-75} = \frac{(1080)(1350 - 900)}{(308)(3500.0)} = 0.458 \text{ s}$$

$$t_{75-95} = \frac{(1080)(1710 - 1350)}{(308)(1822.9)} = 0.6925 \text{ s}$$

and, therefore, the total time to 95% of synchronous speed (or total starting time) is the sum of the times for each interval, or approximately 2.38 s. It can be seen how a similar technique can be applied to the speed-torque starting characteristic of a wound rotor motor (see Figure 2) to determine the required time interval for each step of rotor-starting resistance. The results of such an investigation can then be used to specify and set timers that operate resistor switching contactors or program the control of a liquid rheostat.

The current drawn during various starting intervals can be obtained from a speed-current curve, such as the typical one shown in Figure 11. This example has assumed full voltage available to the motor terminals, which is an inaccurate assumption in most cases. Actual voltage available can be calculated at each time interval. The accelerating torque will then change by the square of the calculated voltage.

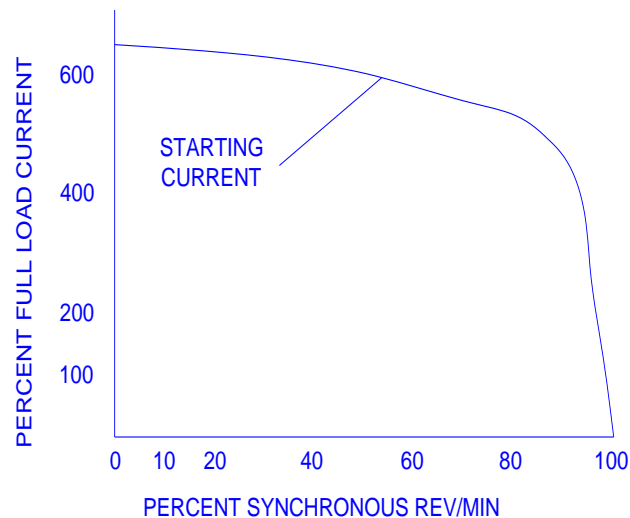

Figure 11. Typical motor speed-current characteristic

This process can be performed by graphically plotting a reduced voltage speed-torque curve proportional to the voltage calculated at each time interval, but this becomes tedious in a hand calculation. Sometimes, in the interest of simplicity, a torque corresponding to the motor terminal voltage at the instant of the maximum voltage dip is used throughout the starting interval. More accurate results are possible with digital computer program analysis.

25.Summary

Several methods for analyzing motor-starting problems have been presented. Types of available motor-starting studies range from simple voltage drop calculation to the more sophisticated motor speed-torque and acceleration time study that approaches a transient stability analysis in complexity. Each study has an appropriate use, and the selection of the correct study is as important a step in the solution process as the actual performance of the study itself.

Examples presented here should serve as a guide for determining when to use each type of motor-starting study, what to expect in the way of results, and how these results can be beneficially applied. The examples should also prove useful in gathering the required information for the specific type of study chosen. Experienced consulting engineers and equipment manufacturers can give valuable advice, information, and direction regarding the application of motor-starting studies as well.