



**PDHonline Course E650 (4 PDH)**

---

# **Understanding Three-Phase Transformers**

*Instructor: Ralph Fehr, Ph.D., PE and John Huang, PE*

**2020**

**PDH Online | PDH Center**

5272 Meadow Estates Drive  
Fairfax, VA 22030-6658  
Phone: 703-988-0088  
[www.PDHonline.com](http://www.PDHonline.com)

An Approved Continuing Education Provider

## Understanding Three-Phase Transformers

Ralph Fehr, Ph.D., P.E. and John Huang, Ph.D., P.E.

Transformers are indispensable components of a power system. By allowing voltage and current levels to be adjusted, transformers solve many practical problems that would otherwise be very difficult to overcome. For example, if power is generated at a reasonable generation voltage, say 18 kV, without the ability to change voltage levels, all circuits supplied by that generator would have to operate at 18 kV. Generating power at a substantially higher voltage is not practical due to insulation design issues involving rotating machines. For a given amount of power, an 18 kV circuit must carry a certain number of amperes of current. If the generator is rated at 500 MVA, the three-phase current would be

$$I = \frac{500,000 \text{ kVA}}{18 \text{ kV} \sqrt{3}} = 16,038 \text{ A.}$$

Such a high current would produce excessive voltage drop and losses. Both of these issues could be overcome by reducing the current to a more manageable level. When this is done, the voltage will increase by the same ratio that the current was decreased. The term *step-up transformer* is used to describe such a transformer, as this describes what the transformer does to the *voltage*. The relationships involving voltage and current will be explored in the next section.

### The Ideal Transformer

Transformers are best understood by first considering and comprehending the *ideal transformer*. An ideal transformer is simply two coils of wire that are electrically isolated from each other and are magnetically coupled. Being “ideal,” the magnetic coupling between the coils is perfect. In other words, all the magnetic flux produced by one winding links the other winding, so there is no *stray flux*. The *self-inductance* and the *resistance* of each winding are also disregarded. Only the *mutual inductance* between the windings is considered.

Per Faraday’s law, when a time-varying magnetic flux cuts a conductor formed into a coil with N turns, a voltage is induced across the coil.

$$V = -N \frac{d\Phi}{dt}$$

Lenz’s law determines the polarity of that voltage. The negative sign in Faraday’s law indicates that the induced voltage is developed with a polarity that would produce a current (if the coil being considered is part of a closed circuit) that would produce a magnetic flux that would oppose the original flux. Fig. 1 shows, by the right-hand rule, that the current I produces a flux that opposes the original flux. This stipulation is necessary for the conservation of energy.

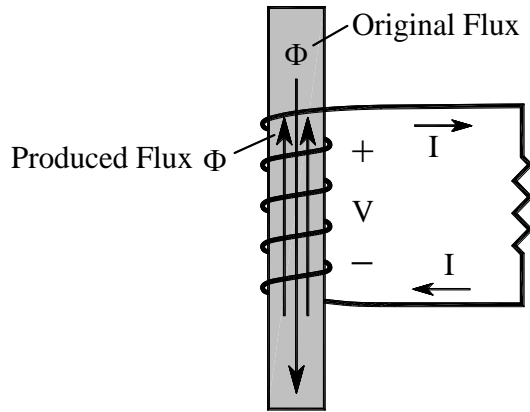

FIGURE 1  
Lenz's Law

The time-varying flux is produced by a time-varying current flowing in one of the coils. By convention, the coil across which a voltage is applied is called the *primary* winding, and the coil across which a voltage is induced is called the *secondary* winding. Since it may not be known which winding will have a voltage applied across it, the use of *primary* and *secondary* can be risky. Transformer manufacturers always designate the windings “high voltage” and “low voltage” to avoid this issue.

In an ideal transformer, the ratio of the number of turns on the high-voltage winding ( $N_H$ ) to the number of turns on the low-voltage winding ( $N_L$ ) defines the *turns ratio* ( $n$ ) for the transformer. The turns ratio also describes the ratio of the voltages across the two windings, so is also referred to as the *voltage ratio*. If each winding in the ideal transformer is part of a closed circuit, the ratio of the currents that flow through each winding is inversely proportional to the turns ratio. These ratios are shown in Fig. 2.

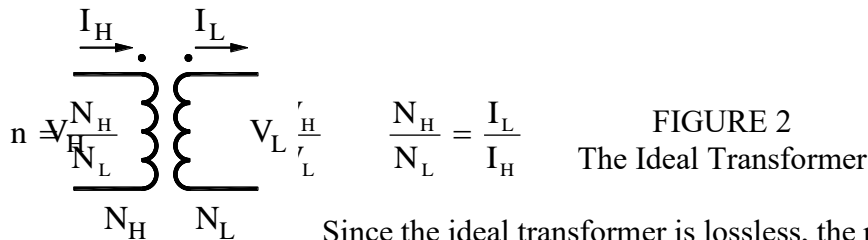

FIGURE 2  
The Ideal Transformer

Since the ideal transformer is lossless, the power handled by the high-voltage winding must equal the power handled by the low-voltage winding.

$$V_H I_H = V_L I_L$$

Also, an impedance put across the low-voltage windings appears to be a much higher impedance when viewed from the high-voltage circuit. This can be seen by writing the high-voltage circuit quantities in terms of the low-voltage circuit quantities:

$$V_H = n V_L$$

$$I_H = \frac{1}{n} I_L$$

Dividing the voltage equation by the current equation gives

$$Z_H = n^2 Z_L.$$

### Transformer Circuit Model

The characteristics that were disregarded in the ideal transformer model can be accounted for in a lumped-parameter circuit model to realistically represent an actual transformer. Figure 3 shows a circuit model representing an actual transformer.

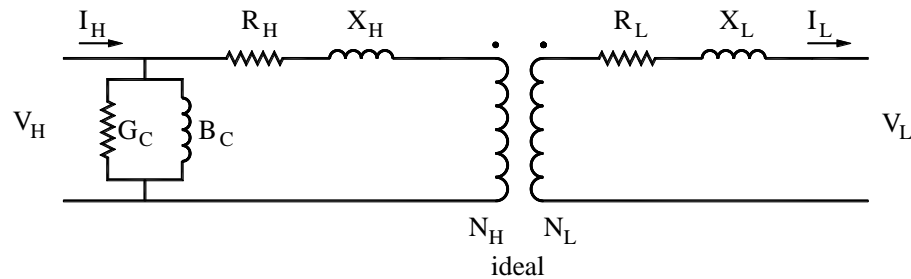

FIGURE 3  
Transformer Circuit Model

The resistances  $R_H$  and  $R_L$  represent the resistances of the high-voltage and the low-voltage windings, respectively. The inductive reactances  $X_H$  and  $X_L$  represent the self-inductances of the high-voltage and the low-voltage windings, respectively, multiplied by the radian frequency.

$$X_H = \omega L_H = 2\pi f L_H$$

$$X_L = \omega L_L = 2\pi f L_L$$

$G_C$  paralleled with  $B_C$  make up the core branch of the model.  $G_C$  is the shunt conductance representing hysteresis and eddy currents.  $B_C$  is the shunt susceptance which represents the magnetization current for the core. The total current flowing through both  $G_C$  and  $B_C$  voltage dependent and is the no-load current of the transformer, and can be measured using the open circuit test, which measures  $I_H$  with the low-voltage terminals open-circuited.

The losses in a transformer are very low compared to the amount of power the transformer can handle; in fact, transformers are among the most efficient machines that can be built, with efficiencies of large transformers often exceeding 99%. But even at a loss rate of 1%, the losses in a transformer should not be overlooked. Think about the losses in a 750 MVA generator step-up transformer with an efficiency of 99% -- that's 7.5 MW of losses (enough to supply about 1500 homes with electricity!)

The ideal transformer provides the turns ratio for the model. Although fairly straightforward, the turns ratio complicates calculations involving systems containing transformers. In the next section, a calculation method will be introduced that makes each transformer turns ratio in the system appear to be 1:1, thereby effectively eliminating the transformers and making the entire electrical system to appear as a single circuit. That calculation method is the *per-unit system*.

### The Per-Unit System of Calculation

The complications caused by the transformer turns ratio are actually quite serious and need to be analyzed. Consider the following one-line diagram, showing a transformer with turns ratio  $n$  supplied from a bus operating at voltage  $V_H$  and drawing current  $I_H$ . The transformer, then, delivers current  $I_L$  to the low voltage bus, which operates at voltage  $V_L$ . A load impedance  $Z_L$  is connected to the low voltage bus.

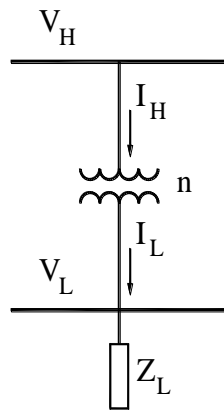

FIGURE 4  
One-Line Diagram

The first step in analyzing the system shown in Fig. 4 is to convert the one-line diagram to a circuit. To do this, an equivalent circuit must replace the transformer one-line symbol. The circuit shown in Fig. 3 would work, but for many types of calculations, a simpler model would suffice. For example, the core branch of the transformer equivalent circuit can be ignored when doing voltage drop calculations, as doing so has little effect on the answer. And for short circuit calculations, the winding resistances can also be ignored, since the very inductive fault current produces little voltage drop across the resistances. And since the  $X/R$  ratio of a transformer tends to be large,  $X \gg R$ , giving further justification to neglect the resistances. So for fault calculations, the transformer equivalent circuit could be shown as a single inductive reactance (the  $X$  on one side of the ideal transformer could be reflected to the other side of the ideal transformer, then the two reactances could be combined in series to yield a single reactance. This circuit is shown in Fig. 5.

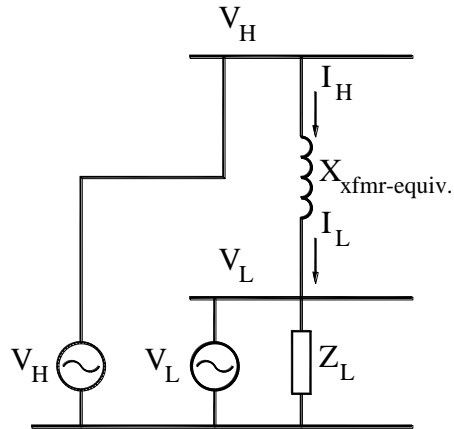

FIGURE 5  
Circuit representation  
of Figure 4

Examining Fig. 5, a serious problem is realized: the current entering the inductance representing the transformer is different from the current leaving the inductance ( $I_H \neq I_L$ ). This seems like a violation of Kirchhoff's Current Law (KCL), but KCL applies to *an* electric circuit. The transformer is actually *two* electric circuits linked by a magnetic circuit. While that technicality explains the apparent KCL violation, the fact that  $I_H \neq I_L$  is still a problem. Recall the three equations describing how magnitudes change when moving from one electric circuit of a transformer to the other:

$$V_H = n V_L, \quad I_H = \frac{1}{n} I_L, \quad \text{and} \quad Z_H = n^2 Z_L.$$

There is one specific value of turns ratio that makes high-side current and low-side current equal, namely  $n=1$ . If  $n=1$ , then the circuit in Fig. 5 can be analyzed. In fact, if  $n=1$ , then  $V_H = V_L$ ,  $I_H = I_L$ , and  $Z_H = Z_L$ . But other than building a transformer with an equal number of turns on both windings (as with an isolation transformer), how can  $n=1$ ? Perhaps some mathematical trickery can be used to make  $n$  appear to have a value of 1. This “trickery” is the per-unit system.

The per-unit system uses dimensionless quantities instead of electrical units (volts, amps, ohms, watts, etc.). The per-unit system, when properly applied, changes all transformer turns ratios to 1. This way, as one moves from the high-voltage circuit of the transformer to the low-voltage circuit, the voltage, current, and impedance are all unaffected, making the two electric circuits appear as one.

The per-unit system relies on the establishment of four *base quantities*. The required base quantities are: *base power*, *base voltage*, *base current*, and *base impedance*. The base quantities are selected by the person doing the problem. The numeric values of these base quantities are arbitrary – any number will work except zero. This is because the per-unit system is a linear mathematical transformation. The problem to be solved is transformed into the per-unit system, solved, and then transformed back to electrical quantities. Since the transformation back to electrical quantities is the inverse of the transformation into the per-unit system, the base quantities which define the transformations can assume any non-zero numeric value.

Of the four base quantities, two are mathematically independent. The other two are then defined by the first two. For example, if voltage and current are assumed to be independent, power can

be thought of as the product of voltage and current, and impedance as the quotient of voltage and current. The typical way to apply the per-unit system is to arbitrarily assign the power and voltage bases, then using the mathematical relationships between the electrical quantities to determine the current and impedance bases.

Typically, the base power (kVA or MVA base) is selected arbitrarily, often as 10 or 100 MVA. The power base is constant through the entire system. The base voltage (kV base) is frequently assigned as the nominal operating voltage at a given point in the system. At every voltage transformation, the base voltage is adjusted by the transformer turns ratio. Therefore, many different base voltages may exist throughout the system. The proper selection of voltage bases throughout the system effectively makes the transformer turns ratios equal to one, thus removing the complications introduced by the transformer turns ratios.

After the power and voltage bases are chosen, the other two base quantities can be calculated from the established bases by using the formulas

$$\text{Base Current} = \frac{\text{Base kVA}_{3\Phi}}{\sqrt{3} \times \text{Base kV}_{L-L}}$$

and

$$\text{Base Impedance} = \frac{(\text{Base kV}_{L-L})^2}{\text{Base MVA}_{3\Phi}},$$

where the subscripts  $3\Phi$  and L–L respectively denote three-phase power and line-to-line voltage.

Actual electrical quantities are converted to dimensionless per-unit quantities using the formula

$$\text{Per – Unit Quantity} = \frac{\text{Actual Quantity}}{\text{Base Quantity}}.$$

Often, a per-unit quantity must be converted from a particular base to a new base. Toward that end, we use the relationship

$$\text{Per – Unit Quantity}_{\text{New}} = \text{Per – Unit Quantity}_{\text{Old}} \times \left( \frac{\text{kV Base}_{\text{Old}}}{\text{kV Base}_{\text{New}}} \right)^2 \times \left( \frac{\text{kVA Base}_{\text{New}}}{\text{kVA Base}_{\text{Old}}} \right).$$

Consider the power system shown below:

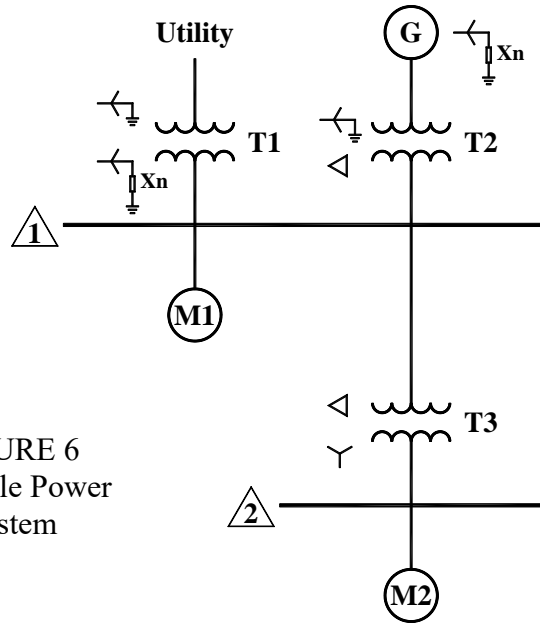

FIGURE 6  
Example Power  
System

Rated Voltages:

Utility Source: 12.47 kV

Generator: 460 V

Transformers

T1: 13.2 kV / 4.16 kV

T2: 460 V / 4 kV

T3: 4.16 kV / 480 V

Motors

M1: 4000 V

M2: 460 V

If the base voltage at Bus 1 is arbitrarily chosen to be 4.16 kV, what must be the base voltages at the utility connection point, the generator terminals, and Bus 2 so that the turns ratio of each transformer appears to be 1?

Starting with the given base voltage at Bus 1 and applying the turns ratio of transformer T1,

$$V_{\text{base(Utility)}} = 4.16 \text{ kV} \left( \frac{13.2 \text{ kV}}{4.16 \text{ kV}} \right) = 13.2 \text{ kV} .$$

Starting with the given base voltage at Bus 1 and applying the turns ratio of transformer T2,

$$V_{\text{base(Generator)}} = 4.16 \text{ kV} \left( \frac{460 \text{ V}}{4000 \text{ V}} \right) = 478.4 \text{ V} .$$

Starting with the given base voltage at Bus 1 and applying the turns ratio of transformer T3,

$$V_{\text{base(Bus 2)}} = 4.16 \text{ kV} \left( \frac{480 \text{ V}}{4160 \text{ V}} \right) = 480 \text{ V} .$$

So the base voltage at one random bus is arbitrary, but every other bus has its base voltage defined by the arbitrarily chosen voltage base multiplied by the product of the turns ratios of each transformer one must pass through to get from the arbitrarily-assigned bus to the bus being considered. This process of assigning base voltages makes each turns ratio appear to be 1.

### Transformer Impedance

A transformer's impedance is an important parameter that helps determine its suitability for a given application. Transformer impedance is expressed in percent based on the self-cooled kVA rating. The impedance is numerically equal to the



percentage of rated voltage that would have to be applied to the primary terminals to cause rated current to flow from the short-circuited secondary terminals. This concept is illustrated in Fig. 7, where  $x$  equals the nameplate value  $\%Z$  of the transformer.

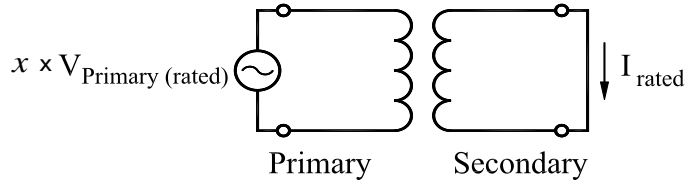

FIGURE 7  
Definition of Transformer Impedance

Note that the percent impedance, which is simply the per unit impedance times 100, is numerically the same whether referred to the high-voltage circuit or the low-voltage circuit. If the impedance were expressed in ohms, the ohmic value would differ by a factor of  $n^2$  when viewed through the transformer. Also, the ohmic impedance would vary tremendously, over orders of magnitude, when comparing very large transformers to very small transformers, while the percent impedance varies over a rather small range, say 2% to 14%, regardless of the size of the transformer.

Transformer impedance varies according to design parameters, particularly kVA rating and basic lightning impulse insulation level (BIL). In general, impedance increases with kVA rating, and also increases with BIL. Most substation class transformers have an impedance in the 5.5% to 7.5% range, but specific designs can cause the impedance to lie outside this range. Since transformer impedance is critical for calculating voltage drop and short circuit magnitudes, actual nameplate data should be used whenever possible.

### Common Three-Phase Connections

Although many three-phase transformer connections, two particular connections, the *delta* and the *wye*, make up most of the three-phase connections commonly encountered. It is important to understand the advantages and disadvantages of each connection type so the proper transformer connections can be determined for a given application.

## The Delta Connection

The delta connection is usually a three-wire, ungrounded circuit. Delta circuits work well to supply balanced loads, such as three-phase motors. Requiring only three conductors, delta-connected circuits are economical to construct. As the load currents supplied by the delta circuit become unbalanced, the voltages also become unbalanced. Unbalanced voltages can lead to operational problems, particularly for three-phase motors. Also, being an ungrounded fault, ground fault protection is complicated and ground faults require more time to clear than they would on a comparable grounded system. Delta-connected circuits block zero-sequence currents and triplen harmonics by providing a path in which they can circulate, which can be advantageous on systems containing large magnitudes of harmonic currents. And delta-connected circuits provide only one three-phase voltage – the line-to-line voltage.

## The Wye Connection

The wye connection is usually a four-wire, grounded circuit. Wye circuits are desirable to supply single-phase loads, as these loads frequently become unbalanced. As the load currents supplied by the wye circuit become unbalanced, the voltages tend to remain well balanced, as the current imbalance is returned to the source by the fourth, or neutral, conductor. Wye-connected windings have no effect on zero-sequence currents or triplen harmonics. The ground reference provides fast detection and clearing of ground faults, and wye-connected systems provide both line-to-line and line-to-neutral voltages. Single-phase loads are usually connected line-to-neutral to keep the phase voltages balanced.

## The Delta-Wye Transformer

Many of the advantages of the delta connection and the wye connection can be realized when constructing a three phase transformer having one set of windings configured in delta and the other set of windings configured in wye. This configuration, the *delta-wye transformer*, is the most common three-phase transformer configuration.

A delta-wye transformation can be accomplished in two different ways. Three identical single-phase transformers can be externally connected to form a delta-wye bank. Or, three sets of windings connected in delta and three sets of windings connected in wye can be wound on a single three-phase core. While the two designs are very much different in their magnetic circuits, they are electrically identical. While many delta-wye transformers may be constructed as a single three-phase unit, it may be clearer to visualize and analyze the device as three single-phase transformers.

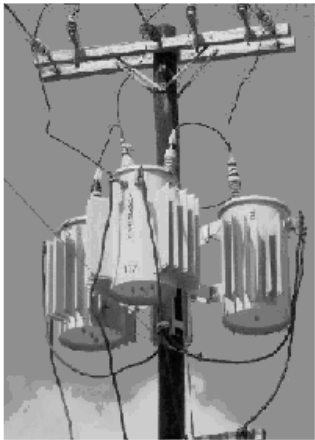

FIGURE 8  
Three Single-Phase Transformers  
in a Delta-Wye Bank

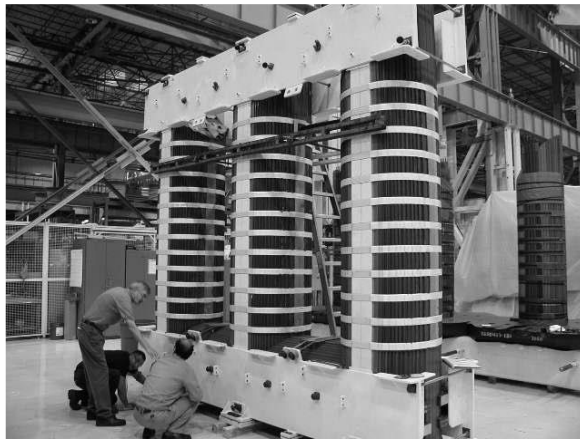

FIGURE 9  
Core and Coil Assembly  
of a Three-Phase  
Delta-Wye Transformer

Figure 10 shows a delta-wye transformer in four different ways: as a *connection diagram*, as a *schematic diagram*, as a *phasor diagram*, and *mathematically*. Some relationships may be seen more easily in one of the four formats than the others. By having all four in front of you, you will more easily learn how the delta-wye transformer works.

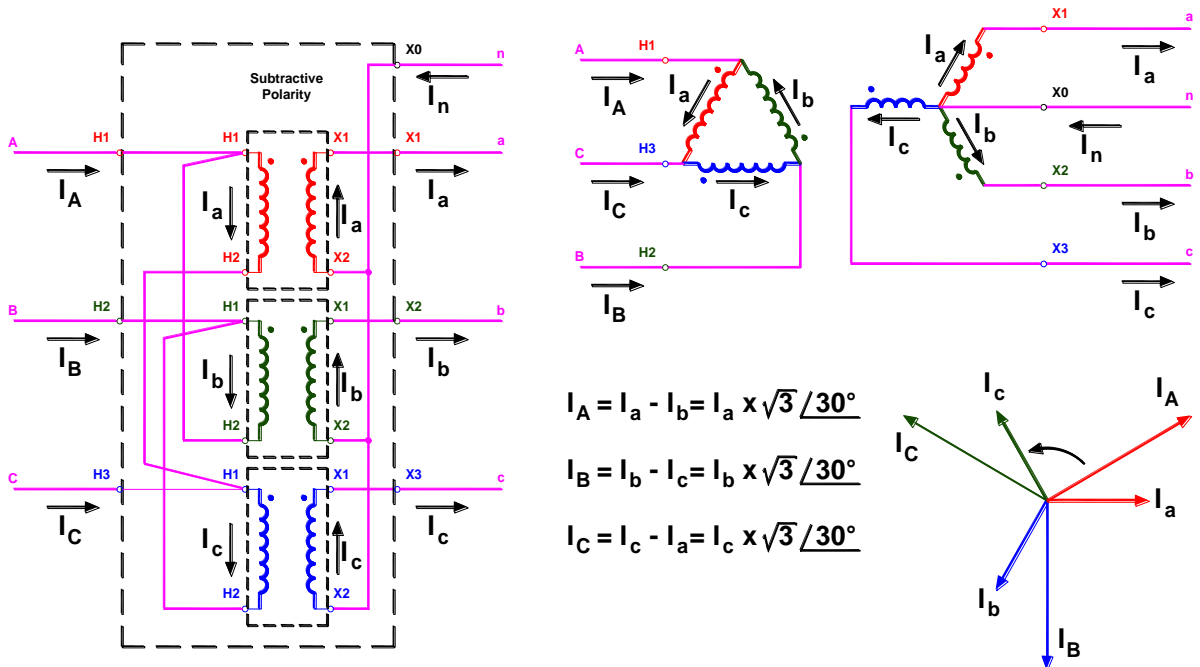

FIGURE 10  
Delta-Wye Transformer

Starting with the connection diagram on the left, both single-phase and three-phase implementations can be seen. Looking at the large dashed rectangle and ignoring the three smaller dashed rectangles, the three-phase implementation is shown. The large dashed rectangle represents the tank of the three-phase unit. Everything inside the rectangle is internal to the transformer. The internal connections are made at the factory and cannot be changes. Seven bushings provide access to install the transformer. On the left, bushings H1, H2, and H3 are the high-voltage bushings and provide connection points for the high-voltage phases. On the right, bushings X1, X2, and X3 provide connection points for the low-voltage phases, and bushing X0 provides access to the neutral.

Alternately, the large dashed rectangle can be ignored, and the three smaller dashed rectangles represent the tanks of three single-phase transformers that can also provide the delta-wye transformation. Each single-phase transformer has four bushings (H1, H2, X1, and X2). The connections between these bushings are made up with insulated cable jumpers interconnecting the three transformers. These jumpers are clearly seen in Fig. 8.

Identifying the delta- and wye-connected windings on the connection diagram is difficult, although by starting at the H1 end of the red winding, moving through the red winding, then following the jumper from red H2 to blue H1, through the blue winding, then following the jumper from blue H2 to green H1, through the green winding, then following the jumper from green H2 to red H1, the high-voltage delta can be traced. Similarly, the non-polarity (X2) ends of the three low-voltage windings are tied together and connected to the X0 bushing, while the polarity (X1) ends of the windings are connected to bushings X1 through X3, thus forming a wye connection. The delta and wye are much more obvious on the schematic diagram in the top right of Fig. 10.

To develop the phasor diagram and the mathematical relationships, we must analyze the behavior of the delta-wye transformer. We can perform the analysis using a voltage-based or a current-based method. Voltage, being a subtraction of two potential phasors (potential difference) is very abstract and difficult, if not impossible, to visualize. Current on the other hand is simply a flow of electrical charges, and can easily be visualized. So we will develop a method of current-based analysis and apply it to the delta-wye transformer. This general method can be applied to any type of transformer connection, regardless of its complexity. If a voltage analysis is needed, the current-based method can still be used, and since Ohm's law states that voltage and current are linearly dependent, the I variables can be replaced with V variables in the last step of the analysis, thus giving a voltage analysis of the transformer.

To begin the current-based analysis, we start with the electric circuit where the line current equals the phase current. This is the wye circuit since the line currents (labeled  $I_a$ ,  $I_b$ , and  $I_c$ ) are the same as the currents through the windings (phase currents), as can be seen in Fig. 11. This is not the case with the delta circuit.

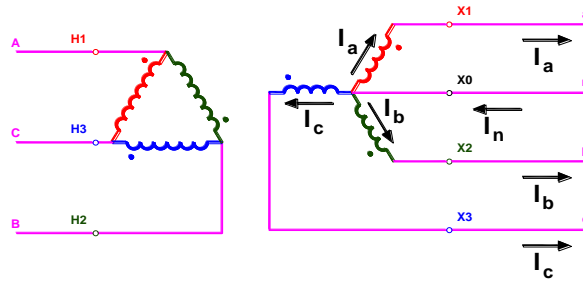

FIGURE 11  
Delta-Wye Transformer Schematic Diagram

After all the currents in the wye circuit are labeled, the currents in the delta-connected windings can be labeled. The current flowing in a high-voltage winding is smaller than the current flowing in the corresponding low-voltage winding by a factor of  $1/n$ , where  $n$  is the turns ratio. Carrying factors of  $1/n$  through the analysis would be cumbersome. If per-unit currents are used, the current flowing through the high-voltage winding equals the current flowing through the corresponding low voltage winding, since the per-unit system makes the turns ratio appear to be 1. The direction of the high-voltage winding currents is determined by the *dot convention*. If an instantaneous current direction is *out of* the dotted terminal in the low-voltage circuit, the high-voltage winding will have a current flowing *into* its dotted terminal. So, using per-unit currents, the currents through the high-voltage windings can be labeled, as shown in Fig. 12.

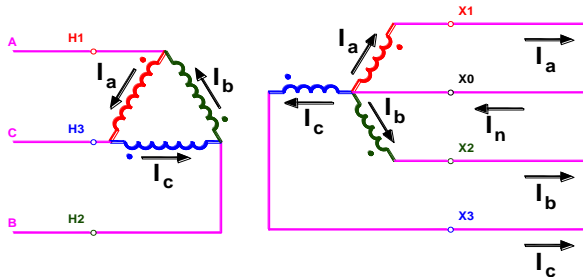

FIGURE 12  
High-Voltage Winding Currents Labeled

Finally, the high-voltage circuit line currents can be determined by writing node equations at the corners of the delta. Upper-case subscripts are used to distinguish high-voltage line currents from low-voltage line currents, and the high-voltage line currents are drawn flowing into the transformer, as shown in Fig. 13.

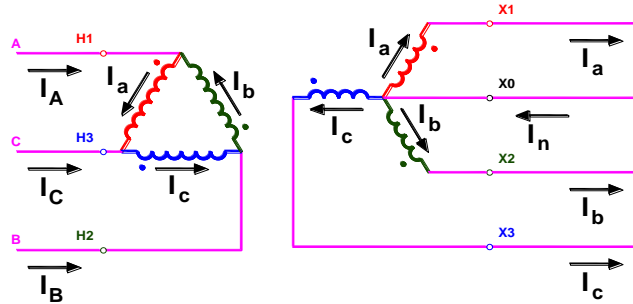

FIGURE 13  
High-Voltage Circuit Line Currents labeled

At the top corner of the delta,

$$I_A = I_a - I_b.$$

Similarly, at the other two nodes,

$$I_B = I_b - I_c \quad \text{and} \quad I_C = I_c - I_a.$$

If a balanced set of positive sequence (meaning the phasors are sequenced *a-b-c*) currents are assumed, the relationship between the high-voltage line currents and low-voltage line currents can be found. Let  $I_a = 1/0^\circ$ ,  $I_b = 1/240^\circ$ , and  $I_c = 1/120^\circ$ . Substituting these values into the node equations developed above,

$$I_A = I_a - I_b = 1/0^\circ - 1/240^\circ = \sqrt{3} /30^\circ$$

$$I_B = I_b - I_c = 1/240^\circ - 1/120^\circ = \sqrt{3} /270^\circ$$

$$I_C = I_c - I_a = 1/120^\circ - 1/0^\circ = \sqrt{3} /30^\circ.$$

Constructing a phasor diagram showing the three low-voltage circuit line currents and the three high-voltage line currents, as in Fig. 14, reveal the mathematical relationships between the currents.

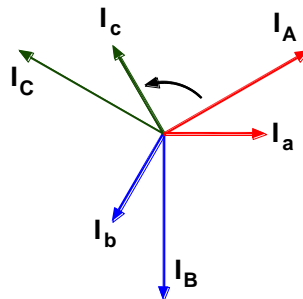

FIGURE 14  
Phasor Diagram of Delta-Wye Transformer

It can be seen that each high-voltage circuit phasor is longer than its low-voltage circuit counterpart by a factor of  $\sqrt{3}$  and leads it by  $30^\circ$ . These relationships are shown in Fig. 15.

$$I_A = I_a - I_b = I_a \times \sqrt{3} / 30^\circ$$

$$I_B = I_b - I_c = I_b \times \sqrt{3} / 30^\circ$$

$$I_C = I_c - I_a = I_c \times \sqrt{3} / 30^\circ$$

FIGURE 15  
Mathematical Relationships between High-Voltage circuit Line Currents and Low-Voltage Circuit Line Currents

In this example, the high-voltage phasors *lead* the low-voltage phasors by 30°. This constitutes an *ANSI Standard* delta-wye transformer. Lagging high-voltage phasors would constitute an *ANSI Non-Standard* delta-wye transformer. By using both standard and non-standard transformers, and by connecting the phases to different bushings (instead of A to H1, B to H2, and C to H3 as in this example), a delta-wye transformer can produce phase shifts of 30°, 90°, 150°, 210°, 270°, and 330°.

Please note that if voltage relationships are needed instead of current relationships, the I variables simply need to be changed to V variables.

The per-unit current-based analysis of the delta-wye transformer that was just completed can be used to analyze any type of transformer connection. Let's apply it to a more complicated connection. Figure 16 shows a three-winding transformer used to supply a six-phase system from a three-phase source.

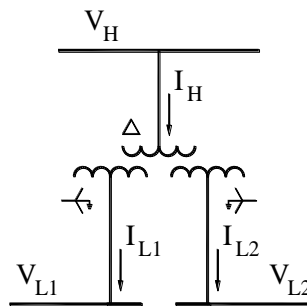

FIGURE 16  
Three-Winding Transformer One-Line Diagram

V<sub>H</sub> is a three-phase system which supplies the delta-connected high-voltage windings. The two wye-connected low-voltage windings differ in phase by 180° relative to each other, so the two low-voltage buses V<sub>L1</sub> and V<sub>L2</sub> actually comprise a six-phase system. High phase order system such as this are excellent for supplying electronic load, such as variable-frequency drives, as they produce less harmonic content than a three-phase system would. The schematic diagram for this transformer is shown in Fig. 17. Please note that although the neutral is drawn as part of bus V<sub>L1</sub>, it is actually shared by both V<sub>L1</sub> and V<sub>L2</sub>.

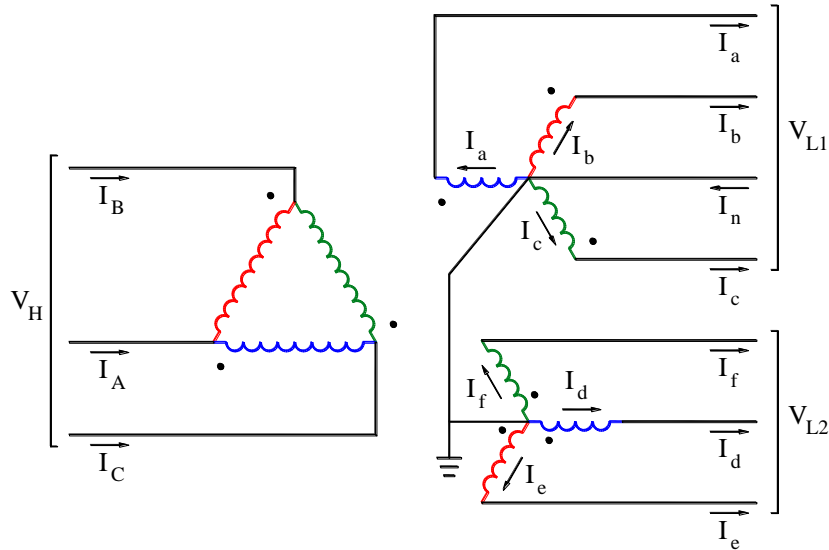

FIGURE 17  
Three-Winding Transformer Schematic Diagram

When transferring the transformer winding currents from the low-voltage circuits to the high-voltage circuit, careful attention must be paid to the winding polarities. Looking at the blue winding, current  $I_a$  leaves the dotted terminal, so an equal per-unit current must enter the dotted terminal on the high-voltage side. But in circuit  $V_{L2}$ , current  $I_d$  enters the dotted terminal of the blue winding, so a current  $I_d$  must leave the blue winding in the high-voltage circuit. This means  $I_a$  and  $I_d$  oppose each other in the high-voltage, and that they are  $180^\circ$  out of phase in the low-voltage circuits. So in the high-voltage circuit, a net current of  $I_a - I_d$  will be shown flowing into the dotted terminal. The other windings are treated similarly, as shown in Fig. 18.

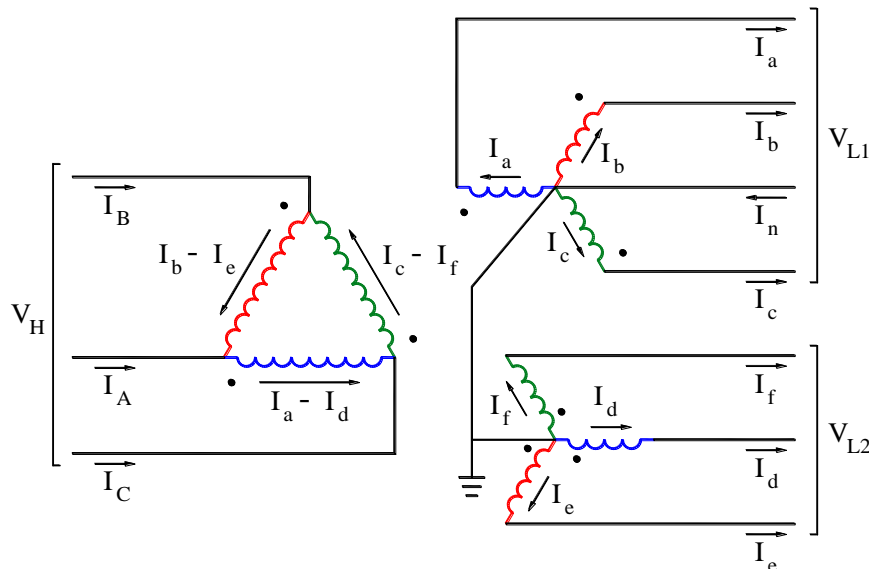

FIGURE 18  
Schematic Diagram with All Currents Labeled



Now, a balanced set of positively-sequenced phasors can be assumed for one of the low-voltage circuits. Starting with  $V_{L1}$ , we can assume  $I_a = 1/0^\circ$ ,  $I_b = 1/240^\circ$ , and  $I_c = 1/120^\circ$ . Since the polarities of the  $V_{L2}$  windings are opposite from the  $V_{L1}$  windings. We know the corresponding currents are  $180^\circ$  out of phase from their  $V_{L1}$  counterparts. This means  $I_d = 1/180^\circ$ ,  $I_e = 1/60^\circ$ , and  $I_f = 1/300^\circ$ . Using these values, the high-side line currents can be found by writing node equations at each corner of the delta.

$$I_A = (I_a - I_d) - (I_b - I_e) = I_a + I_e - I_b - I_d = 1/0^\circ + 1/60^\circ - 1/240^\circ - 1/180^\circ = 2\sqrt{3} /30^\circ$$

$$I_B = (I_b - I_e) - (I_c - I_f) = I_b + I_f - I_c - I_e = 1/240^\circ + 1/300^\circ - 1/120^\circ - 1/60^\circ = 2\sqrt{3} /270^\circ$$

$$I_C = (I_c - I_f) - (I_a - I_d) = I_c + I_d - I_a - I_f = 1/120^\circ + 1/180^\circ - 1/0^\circ - 1/300^\circ = 2\sqrt{3} /150^\circ$$

Now, a phasor diagram can be constructed showing all nine line currents.

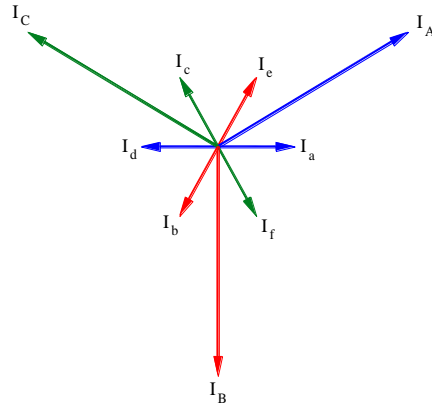

FIGURE 19  
Three-Winding Transformer Phasor Diagram