



PDHonline Course M161 (1 PDH)

The Function of Gate Valves Used in the Oil & Gas Industry

Instructor: Peter Smith, HNC (Mech)

2020

PDH Online | PDH Center

5272 Meadow Estates Drive
Fairfax, VA 22030-6658
Phone: 703-988-0088
www.PDHonline.com

An Approved Continuing Education Provider

The packing train of the valve shown in Figure 3-22 is likewise stressed through the bonnet in conjunction with springs under the nuts of the cover bolts, or with a spring between the bonnet and the packing. However, as the piston moves into the final closing position, a shoulder on the piston contacts a compression ring on top of the packing so that any further progression of the piston tightens the packing still further.

The piston valve shown in Figure 3-23 carries the seat packing on the end of the piston instead of in the valve bore. The packing is supported thereby on its underside by a loose compression ring. When the piston moves into the final closing position, the compression ring comes to rest on a shoulder in the seat bore so that any further progression of the piston causes the compression ring to tighten the packing. Because the packing establishes interference with the seat in the last closing stages only, the operating effort of the valve is lower over a portion of the piston travel than that of the foregoing valves.

The piston valve shown in Figure 3-24 also carries the seat packing on the piston. However, the loose compression ring is replaced by a friction ring that acts as a spring element and, as such, pre-stresses the packing. When the piston moves into the seat, the friction ring comes to rest in the seat bore, and any progression of the piston increases the packing stress.

National standards that apply specifically to piston valves do not exist.

Applications

Duty:

- Controlling flow
- Stopping and starting flow

Service:

- Gases
- Liquids
- Fluids with solids in suspension
- Vacuum

PARALLEL GATE VALVES

Parallel gate valves are slide valves with a parallel-faced gate-like closure member. This closure member may consist of a single disc or twin discs

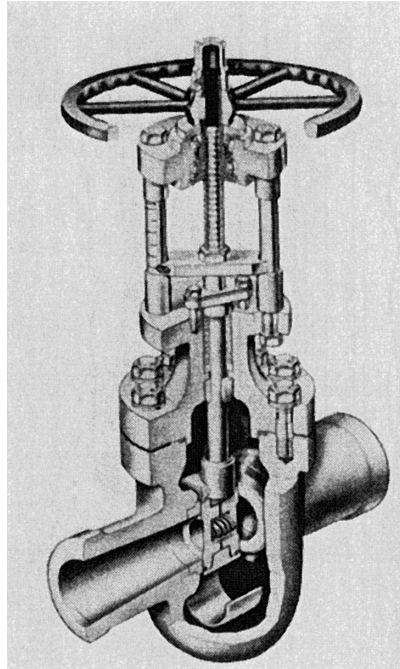

Figure 3-25. Parallel Slide Gate Valve with Converging-Diverging Flow Passage and Follower Eye piece. (Courtesy of Hopkinsons Limited.)

with a spreading mechanism in between. Typical valves of this type are shown in Figure 3-25 through Figure 3-32.

The force that presses the disc against the seat is controlled by the fluid pressure acting on either a floating disc or a floating seat. In the case of twin disc parallel gate valves, this force may be supplemented with a mechanical force from a spreading mechanism between the discs.

One advantage of parallel gate valves is their low resistance to flow, which in the case of full-bore valves approaches that of a short length of straight pipe. Because the disc slides across the seat face, parallel gate valves are also capable of handling fluids, which carry solids in suspension. This mode of valve operation also imposes some limitations on the use of parallel gate valves:

- If fluid pressure is low, the seating force may be insufficient to produce a satisfactory seal between metal-to-metal seatings.

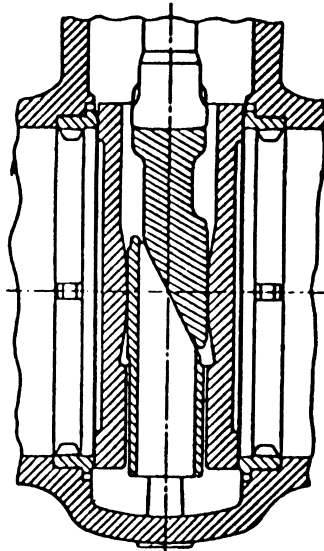

Figure 3-26. Scrap View of Parallel Gate Valve Showing Double-Disc Closure Member with Wedging Mechanism. (Courtesy of Pacific Valves, Inc.)

- Frequent valve operation may lead to excessive wear of the seating faces, depending on magnitude of fluid pressure, width of seating faces, lubricity of the fluid to be sealed, and the wear resistance of the seating material. For this reason, parallel gate valves are normally used for infrequent valve operation only.
- Loosely guided discs and loose disc components will tend to rattle violently when shearing high density and high velocity flow.
- Flow control from a circular disc travelling across a circular flow passage becomes satisfactory only between the 50% closed and the fully closed positions. For this reason, parallel gate valves are normally used for on-off duty only, though some types of parallel gate valves have also been adapted for flow control, for example, by V-porting the seat.

The parallel gate valves shown in Figure 3-25 through Figure 3-28 are referred to as conventional parallel gate valves, and those of Figure 3-29 through Figure 3-32 are referred to as conduit gate valves. The latter are full-bore valves, which differ from the former in that the disc seals the valve body cavity against the ingress of solids in both the open and closed valve positions. Such valves may therefore be used in pipelines that have to be scraped.

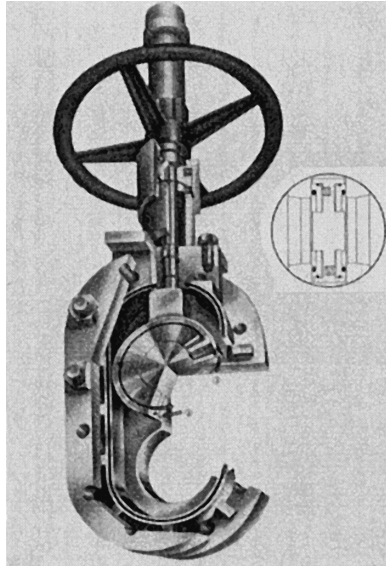

Figure 3-27. Parallel Gate Valve with Scrap View of Seating Arrangement Showing Spring-Loaded Floating Inserts in Disc. (Courtesy of Grove Valve and Regulator Company.)

Conventional Parallel Gate Valves

The valves shown in Figure 3-25 through Figure 3-28 are representative of the common varieties of conventional parallel gate valves.

One of the best known is the valve shown in Figure 3-25, commonly referred to as a parallel slide gate valve. The closure member consists of two discs with springs in between. The duties of these springs are to keep the upstream and downstream seatings in sliding contact and to improve the seating load at low fluid pressures. The discs are carried in a belt eye in a manner that prevents their unrestrained spreading as they move into the fully open valve position.

The flow passage of this particular parallel slide gate valve is venturi shaped. The gap between the seats of the fully open valve is bridged by an eyelet to ensure a smooth flow through the valve. The advantages offered by this construction include not only economy of construction but also a reduced operating effort and lower maintenance cost. The only disadvantage is a slight increase in pressure loss across the valve.

The seating stress reaches its maximum value when the valve is nearly closed, at which position the pressure drop across the valve is near

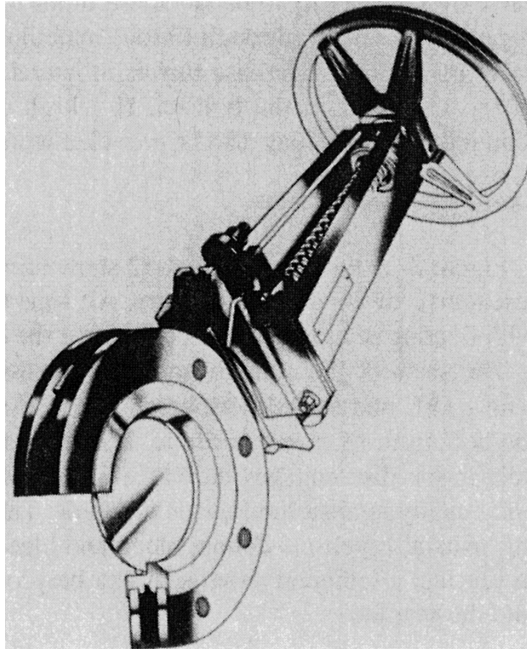

Figure 3-28. Knife Gate Valve. (Courtesy of DeZurik.)

maximum; but the seating area in mutual contact is only a portion of the total seating area. As the disc travels between the three-quarter closed to the nearly closed valve position, the flowing fluid tends to tilt the disc into the seat bore, so heavy wear may occur in the seat bore and on the outer edge of the disc. To keep the seating stress and corresponding seating wear within acceptable limits, the width of the seatings must be made appropriately wide. Although this requirement is paradoxical in that the seating width must be small enough to achieve a high seating stress but wide enough to keep seating wear within acceptable limits, the fluid tightness that is achieved by these valves satisfies the leakage criterion of the steam class, provided the fluid pressure is not too low.

Parallel slide gate valves have other excellent advantages: the seatings are virtually self-aligning and the seat seal is not impaired by thermal movements of the valve body. Also, when the valve has been closed in the cold condition, thermal extension of the stem cannot overload the seatings. Furthermore, when the valve is being closed, a high accuracy in the positioning of the discs is not necessary, thus an electric drive for the valve can be travel limited. Because an electric drive of this type is both economical

and reliable, parallel slide gate valves are often preferred as block valves in larger power stations for this reason alone. Of course, parallel slide gate valves may be used also for many other services such as water, in particular boiler feed water—and oil.

A variation of the parallel slide gate valve used mainly in the U.S. is fitted with a closure member such as the one shown in Figure 3-26. The closure member consists of two discs with a wedging mechanism in between, which, on contact with the bottom of the valve body, spreads the discs apart. When the valve is being opened again, the wedging mechanism releases the discs. Because the angle of the wedge must be wide enough for the wedge to be self-releasing, the supplementary seating load from the wedging action is limited.

To prevent the discs from spreading prematurely, the valve must be mounted with the stem upright. If the valve must be mounted with the stem vertically down, the wedge must be appropriately supported by a spring.

The performance characteristic attributed to parallel slide gate valves also applies largely to this valve. However, solids carried by the flowing fluid and sticky substances may interfere with the functioning of the wedging mechanism. Also, thermal extension of the stem can overload the seatings. The valve is used mainly in gas, water, and oil services.

Conventional parallel gate valves may also be fitted with soft seatings, as in the valve shown in Figure 3-27. The closure member consists here of a disc that carries two spring-loaded floating seating rings. These rings are provided with a bonded O-ring on the face and a second O-ring on the periphery. When the disc moves into the closed position, the O-ring on the face of the floating seating ring contacts the body seat and produces the initial fluid seal. The fluid pressure acting on the back of the seating ring then forces the seatings into still closer contact.

Because the unbalanced area on the back of the floating rings is smaller than the area of the seat bore, the seating load for a given fluid pressure and valve size is smaller than in the previously described valves. However, the valve achieves a high degree of fluid tightness by means of the O-ring even at low fluid pressures. This sealing principle also permits double block and bleed.

The parallel gate valve shown in Figure 3-28 is known as the knife gate valve, and is designed to handle slurries, including fibrous material. The valve owes its ability to handle these fluids to the knife-edged disc, which is capable of cutting through fibrous material, and the virtual absence of a valve body cavity. The disc travels in lateral guides and is forced against

the seat by lugs at the bottom. If a high degree of fluid tightness is required, the valve may also be provided with an O-ring seat seal.

Conduit Gate Valves

Figure 3-29 through Figure 3-32 show four types of valves that are representative of conduit gate valves. All four types of valves are provided with floating seats that are forced against the disc by the fluid pressure.

The seats of the conduit gate valve shown in Figure 3-29 are faced with PTFE and sealed peripherally by O-rings. The disc is extended at the bottom to receive a porthole. When the valve is fully open, the porthole in the disc engages the valve ports so that the disc seals the valve body cavity against the ingress of solids. The sealing action of the floating seats also permits double block and bleed. If the seat seal should fail in service, a temporary seat seal can be produced by injecting a sealant into the seat face.

The conduit gate valve shown in Figure 3-30 differs from the previous one in that the disc consists of two halves with a wedge-shaped

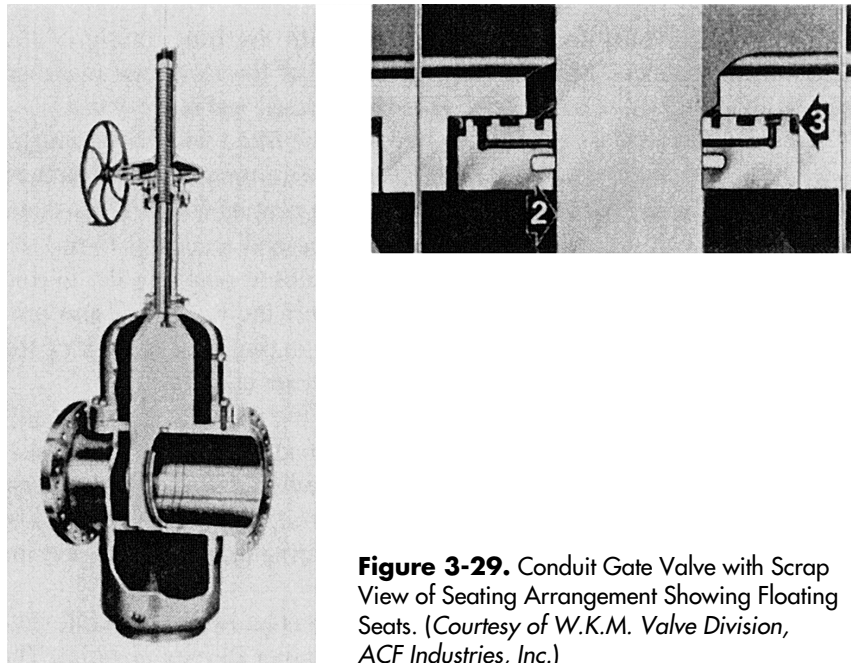

Figure 3-29. Conduit Gate Valve with Scrap View of Seating Arrangement Showing Floating Seats. (Courtesy of W.K.M. Valve Division, ACF Industries, Inc.)

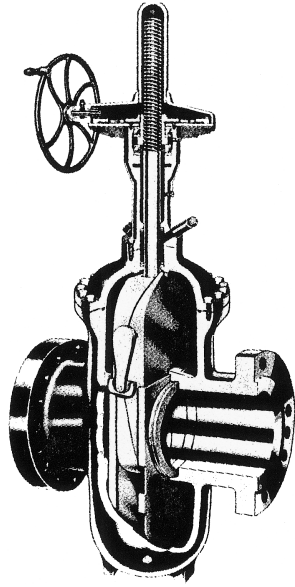

Figure 3-30. Conduit Gate Valve with Floating Seats and Expandable Disc. (Courtesy of W.K.M. Valve Division, ACF Industries, Inc.)

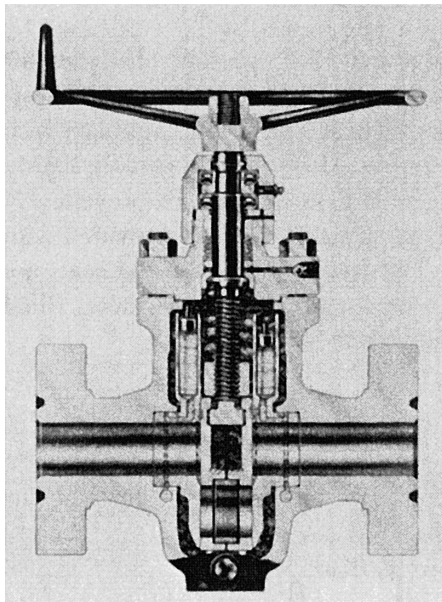

Figure 3-31. Conduit Gate Valve with Automatic Injection of a Sealant to the Downstream Seatings Each Time the Valve Closes. (Courtesy of McEvoy Oilfield Equipment Company.)

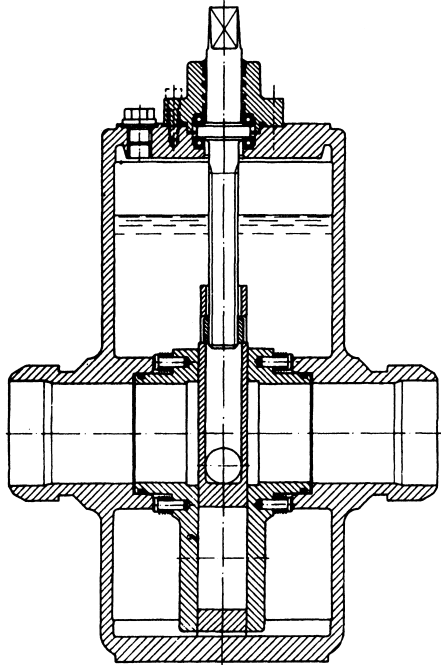

Figure 3-32. Conduit Gate Valve with Metal Seatings and Oil-Filled Body Cavity for Heavily Dust-Laden Gasses and the Hydraulic Transport of Coal and Ores. (Courtesy of VAG-Armaturen GmbH.)

interface. These halves are interlinked so that they wedge apart when being moved into the fully open or closed positions, but relax in the intermediate position to permit the disc to travel. Depending on the use of the valve, the face of the floating seats may be metallic or provided with a PTFE insert. To prevent the ingress of solids into the valve body cavity during all stages of disc travel, the floating seats are provided with skirts, between which the disc travels. This valve likewise permits double block and bleed. Also, should the seat seal fail in service, a temporary seat seal can be provided by injecting a sealant into the seat face.

The sealing action of the conduit gate valve shown in Figure 3-31 depends on a sealant that is fed to the downstream seat face each time the valve is operated. For this purpose, the floating seats carry reservoirs that are filled with a sealant and topped by a floating piston. The entire valve chamber is, furthermore, filled with a grease that transmits the fluid pressure to the top of the piston of the downstream reservoir. The closure member consists of two discs, which are spread apart by springs. Both the sealant and the body

grease can be replenished from the outside while the valve is in service. Each reservoir filling is sufficient for more than 100 valve operations. This mode of sealing achieves a high degree of fluid tightness at high fluid pressures.

The conduit gate valve shown in Figure 3-32 is especially designed for the hydraulic transport of coal and ore, and the transport of heavily dust-laden gases. The gate, which consists of a heavy wear-resistant plate with a porthole in the bottom, slides between two floating seats that are highly pre-stressed against the disc by means of disc springs. To prevent any possible entry of solids into the body cavity, the seats are provided with skirts for the full travel of the disc. The faces of the disc and seats are metallic and highly polished. The valve chamber is, furthermore, filled with a lubricant that ensures lubrication of the seating faces.

Valve Bypass

The seating load of the larger parallel gate valves (except those with floating seats) can become so high at high fluid pressures that friction between the seatings can make it difficult to raise the disc from the closed position. Such valves are therefore frequently provided with a valved bypass line, which is used to relieve the seating load prior to opening the valve. There are no fast rules about when to employ a bypass, and the manufacturer's recommendation may be sought. Some standards of gate valves contain recommendations on the minimum size of the bypass.

In the case of gases and vapors, such as steam, that condense in the cold downstream system, the pressurization of the downstream system can be considerably retarded. In this instance, the size of the bypass line should be larger than the minimum recommended size.

Pressure-Equalizing Connection

In the case of the conventional double-seated parallel gate valves shown in Figure 3-25 and Figure 3-26, thermal expansion of a liquid trapped in the closed valve chamber will force the upstream and downstream discs into more intimate contact with their seats, and cause the pressure in the valve chamber to rise. The higher seating stress makes it in turn more difficult to raise the discs, and the pressure in the valve chamber may quickly become high enough to cause a bonnet flange joint to leak or the valve body to

deform. Thus, if such valves are used to handle a liquid with high thermal expansion, they must have a pressure-equalizing connection that connects the valve chamber with the upstream piping.

The pressure rise in the valve chamber may also be caused by the reevaporation of trapped condensate, as in the case in which these valves are closed against steam. Both the valve chamber and the upstream piping are initially under pressure and filled with steam. Eventually, the steam will cool, condense, and be replaced to some extent with air.

Upon restart, the steam will enter the upstream piping and, since the upstream seat is not normally fluid-tight against the upstream pressure, will enter the valve chamber. Some of the new steam will also condense initially until the valve body and the upstream piping have reached the saturation temperature of the steam.

When this has happened, the steam begins to boil off the condensate. If no pressure-equalizing connection is provided, the expanding steam will force the upstream and downstream discs into more intimate contact with their seats, and raise the pressure in the valve chamber. The magnitude of the developing pressure is a function of the water temperature and the degree of filling of the valve chamber with water, and may be obtained from Figure 3-33.

The pressure-equalizing connection may be provided by a hole in the upstream disc or by other internal or external means. Some makers of parallel gate valves of the types shown in Figure 3-25 and Figure 3-26 combine the bypass line with a pressure-equalizing line if the valve is intended for steam.

Standards Pertaining to Parallel Gate Valves

Appendix C provides a list of U.S. and British standards pertaining to parallel gate valves.

Applications

Duty:

- Stopping and starting flow
- Infrequent operation

Service:

- Gases

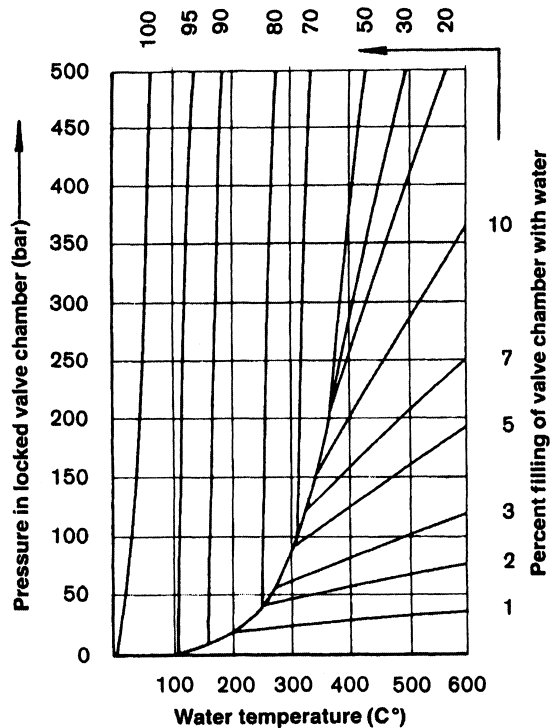

Figure 3-33. Pressure in Locked Valve Chamber as a Result of the Revaporation of Trapped Water Condensate. (Courtesy of Sempell A.G.)

Liquids
 Fluids with solids in suspension
 Knife gate valve for slurries, fibers, powders, and granules
 Vacuum
 Cryogenic

WEDGE GATE VALVES

Wedge gate valves differ from parallel gate valves in that the closure member is wedge-shaped instead of parallel, as shown in Figure 3-34 through Figure 3-45. The purpose of the wedge shape is to introduce a high supplementary seating load that enables metal-seated wedge gate valves to seal not only against high, but also low, fluid pressures. The degree of seat

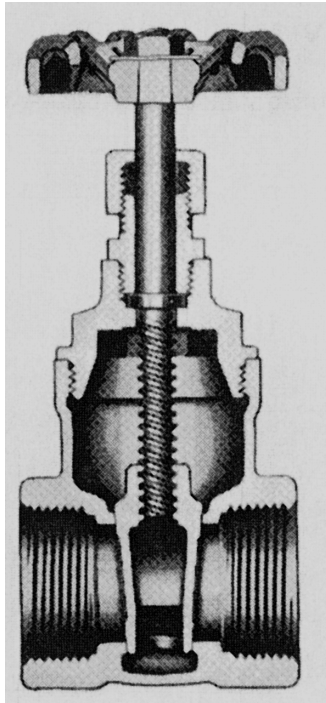

Figure 3-34. Wedge Gate Valve with Plain Hollow Wedge, Screwed-in Bonnet, and Internal Screw. (Courtesy of Crane Co.)

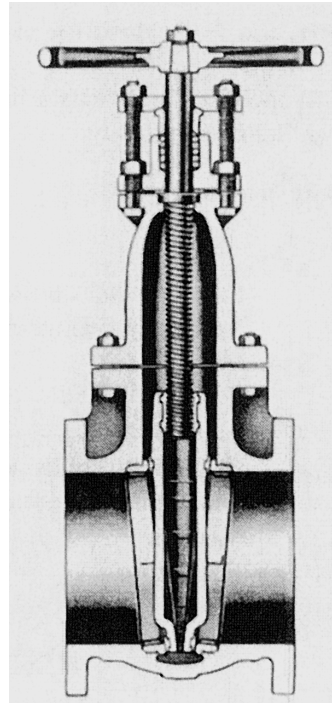

Figure 3-35. Wedge Gate Valve with Plain Hollow Wedge, Bolted Bonnet, and Internal Screw. (Courtesy of Crane Co.)

tightness that can be achieved with metal-seated wedge gate valves is therefore potentially higher than with conventional metal-seated parallel gate valves. However, the upstream seating load is not normally high enough to permit block-and-bleed operation of metal-to-metal seated wedge gate valves.

The bodies of these valves carry guide ribs, or slots, in which the disc travels. The main purpose of these guides is to carry the wedge away from the downstream seat except for some distance near the closed valve position so as to minimize wear between the seatings. A second purpose of the guides is to prevent the disc from rotating excessively while traveling between the open and closed valve positions. If some rotation occurs, the disc will initially jam on one side between the body seatings and the rotate into the correct position before travelling into the final seating position.

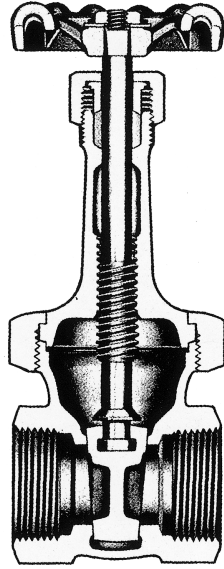

Figure 3-36. Wedge Gate Valve with Plain Solid Wedge, Union Bonnet, and Internal Screw. (Courtesy of Crane Co.)

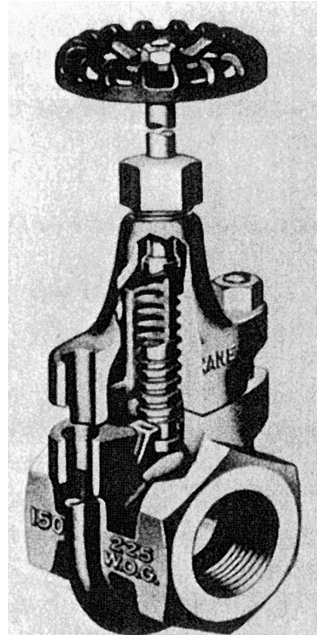

Figure 3-37. Wedge Gate Valve with Clamped Bonnet, Internal Screw. (Courtesy of Crane Co.)

There are also types of wedge gate valves that can dispense with a wedge guide, such as the valve shown in Figure 3-45 in which the wedge is carried by the diaphragm.

Compared with parallel gate valves, wedge gate valves also have some negative features:

- Wedge gate valves cannot accommodate a follower conduit as conveniently as parallel gate valves can.
- As the disc approaches the valve seat, there is some possibility of the seatings trapping solids carried by the fluid. However, rubber-seated wedge gate valves, as shown in Figure 3-44 and Figure 3-45, are capable of sealing around small trapped solids.
- An electrical drive for wedge gate valves is more complicated than for parallel gate valves in that the drive must be torque-limited instead of travel-limited. The operating torque of the drive must thereby be high enough to effect the wedging of the wedge into the seats while the valve

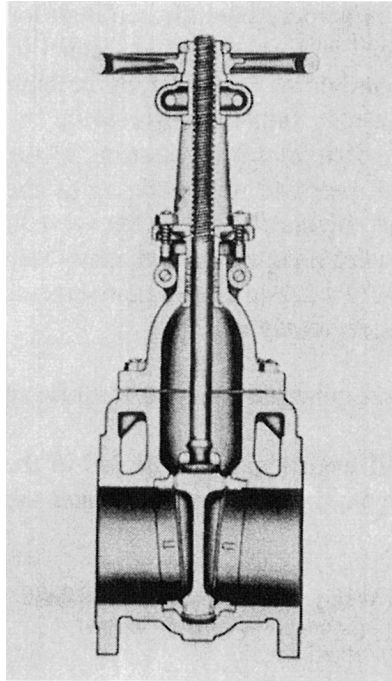

Figure 3-38. Wedge Gate with Plain Solid Wedge, Bolted Bonnet, and External Screw. (Courtesy of Crane Co.)

is being closed against the full differential line pressure. If the valve is closed against zero differential pressure, the wedging of the wedge into the seats becomes accordingly higher. To permit the valve to be opened again against the full differential pressure, and to allow also for a possible increase of the operating effort due to thermal movements of the valve parts, the operator must be generously sized.

The limitations of wedge gate valves are otherwise similar to those of parallel gate valves.

Efforts to improve the performance of wedge gate valves led to the development of a variety of wedge designs; the most common ones are described in the following section.

Variations of Wedge Design

The basic type of wedge is the plain wedge of solid or hollow construction, as in the valves shown in Figure 3-34 through Figure 3-39. This design

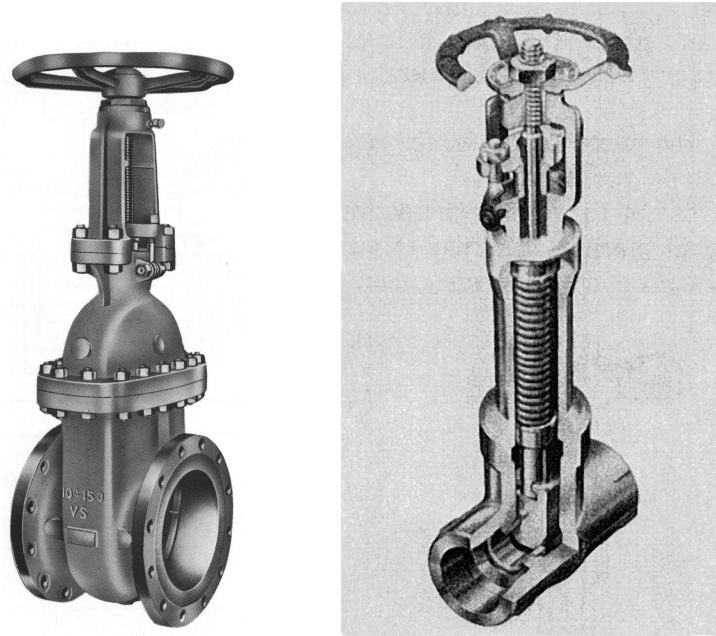

Figure 3-39. Wedge Gate with Plain Solid Wedge, Welded Bonnet, External Screw, Bellows Stem Seal, and Auxiliary Stuffing Box Seal. (Courtesy of Pegler Hattersley Limited.)

has the advantage of being simple and robust, but distortions of the valve body due to thermal and pipeline stresses may unseat or jam the metal-seated wedge. A failure of this kind is more often experienced in valves of light-weight construction.

The sealing reliability of gate valves with a plain wedge can be improved by elastomeric or plastic sealing elements in either the seat or the wedge. Figure 3-40 shows a seat in which the sealing element is a PTFE insert. The PTFE insert stands proud of the metal face just enough to ensure a seal against the wedge.

Efforts to overcome the alignment problem of plain wedges led to the development of self-aligning wedges. Figure 3-41, Figure 3-42, and Figure 3-43 show typical examples. The simplest of these is the flexible wedge shown in Figure 3-41 and Figure 3-42, which is composed of two discs with an integral boss in between. The wedge is sufficiently flexible to find its own orientation. Because the wedge is simple and contains no separate components that could rattle loose in service, this construction has become a favored design.

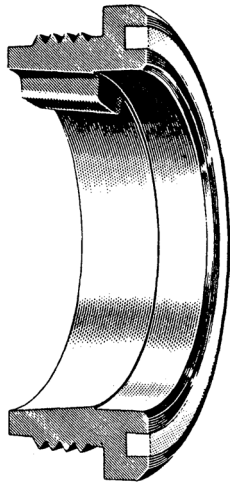

Figure 3-40. Seat of Wedge Gate Valve with PTFE Sealing Insert. (Courtesy of Crane Co.)

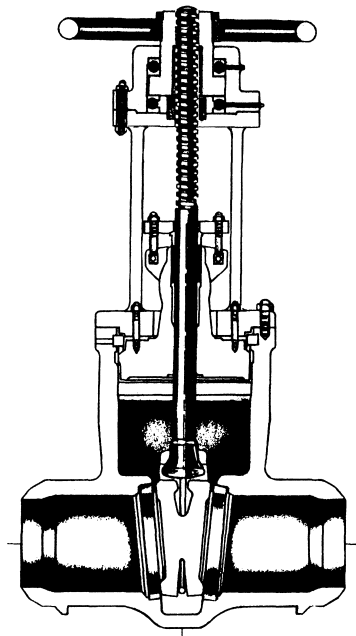

Figure 3-41. Wedge Gate Valve with Flexible Wedge, Pressure-Sealed Bonnet, External Screw. (Courtesy of Crane Co.)

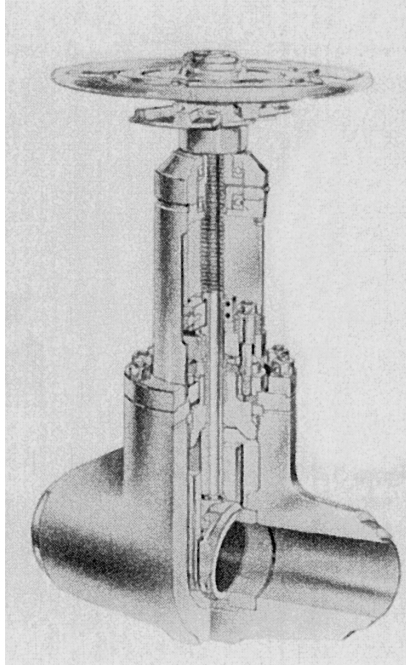

Figure 3-42. Forged Wedge Gate Valve with Pressure-Sealed Bonnet, Incorporating Flexible Wedge with Hard Faced Grooves Sliding on Machined Body Ribs. (Courtesy of Velan Engineering Ltd.)

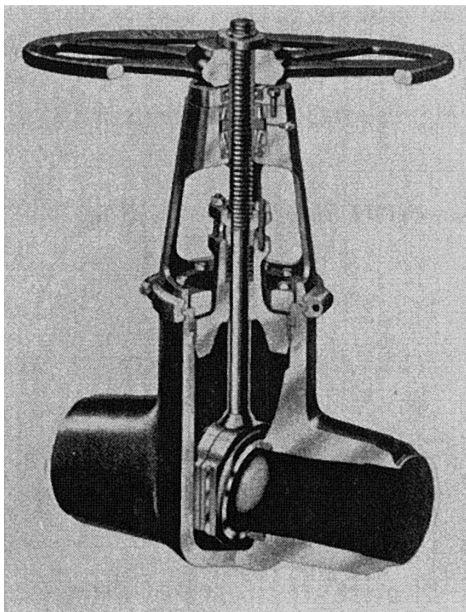

Figure 3-43. Wedge Gate Valve with Two-Piece Wedge, Pressure-Sealed Bonnet, and External Screw. (Courtesy of Edward Valves Inc.)

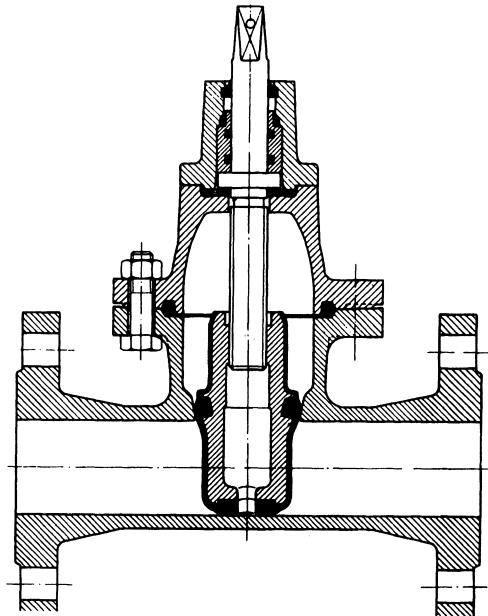

Figure 3-44. Rubber-Seated Wedge Gate Valve without Cavity in Bottom of Valve Body. (Courtesy of VAG-Armaturen GmbH.)

The self-aligning wedge of the valve shown in Figure 3-43 consists of two identical tapered plates that rock around a separate spacer ring. This spacer ring may also be used to adjust the wedge assembly for wear. To keep the plates together, the body has grooves in which the wedge assembly travels.

Rubber lining of the wedge, as in the valves shown in Figure 3-44 and Figure 3-45, led to the development of new seating concepts in which the seat seal is achieved in part between the rim of the wedge and the valve body. In this way, it became possible to avoid altogether the creation of a pocket at the bottom of the valve body. These valves are therefore capable of handling fluids carrying solids in suspension, which would otherwise collect in an open body cavity.

In the case of the valve shown in Figure 3-44, the wedge is provided with two stirrup-shaped rubber rings that face the rim of the wedge at the bottom sides, and the top lateral faces. When the valve is being closed, the rubber rings seal against the bottom and the sidewalls of the valve body and, by a wedging action, against the seat faces at the top.

The wedge of the valve shown in Figure 3-45 is completely rubber lined and forms part of a diaphragm, which separates the operating mechanism

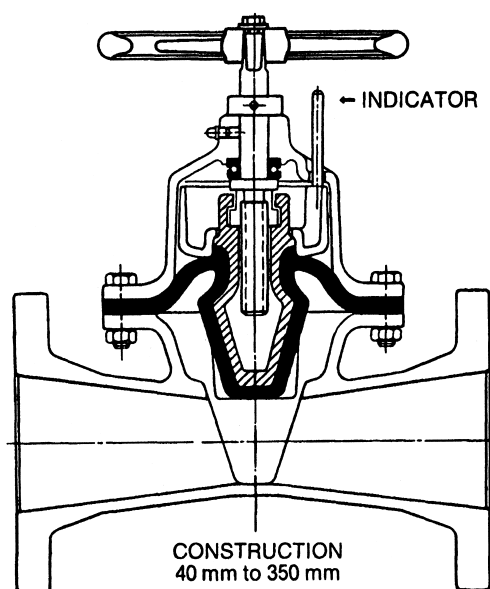

Figure 3-45. Rubber-Seated Wedge Gate Valve Without Cavity in Bottom of Valve Body. (Courtesy of Schmitz & Schulte, D-5093 Burscheid.)

from the flowing fluid. When the valve is being closed, the bottom of the wedge seals against the bottom of the valve body and the body seats. The valve may also be lined with corrosion-resistant materials, and is therefore widely used in the chemical industry.

Connection of Wedge to Stem

The wedge-to-stem connection usually consists of a T-slot in the top of the wedge, which receives a collar on the stem. According to API standard 600, this connection must be stronger than the weakest stem section so that the wedge cannot become detached from the stem while operating the valve.

The T-slot in the wedge may thereby be oriented in line with the flow passage, as in the valves shown in Figure 3-38, Figure 3-39, and Figure 3-41, or across the flow passage as shown in Figure 3-36 and Figure 3-42. The latter construction permits a more compact valve body design and, therefore, has become popular for economic reasons. Also, this construction favorably lowers the point at which the stem acts on the wedge. However, the T-slot must be wide enough to accommodate the play of the wedge in its guide, allowing also for wear of the guide.

There are also exceptions to this mode of wedge-to-stem connection, as in the valves shown in Figure 3-34 and Figure 3-37, in which the stem must carry the entire thrust on the wedge. For this reason, this construction is suitable for low pressure applications only. In the valve shown in Figure 3-43, guide play is virtually absent, allowing the stem to be captured in the wedge.

Wedge Guide Design

The body guides commonly consist either of ribs, which fit into slots of the wedge, or of slots, which receive ribs of the wedge. Figure 3-42 and Figure 3-43 illustrate these guiding mechanisms.

The body ribs are not normally machined for reason of low cost construction. However, the rough surface finish of such guides is not suited for carrying the travelling wedge under high load. For this reason, the wedge is carried on valve opening initially on the seat until the fluid load has become small enough for the body ribs to carry the wedge. This method of guiding the wedge may require considerable play in the guides, which must be matched, by the play in the T-slot for suspending the wedge on the stem.

Once the body ribs begin to carry the wedge upon valve opening, the wedge must be fully supported by the ribs. If the length of support is insufficient, the force of the flowing fluid acting on the unsupported section of the wedge may be able to tilt the wedge into the downstream seat bore. This support requirement is sometimes not complied with. On the other hand, some valve makers go to any length to ensure full length wedge support.

There is no assurance that the wedge will slide on the stem collar when opening the valve. At this stage of valve operation, there is considerable friction between the contact faces of the T-slot and stem collar, possibly causing the wedge to tilt on the stem as the valve opens. If, in addition, the fit between T-slot and stem collar is tight, and the fluid load on the disc is high, the claws forming the T-slot may crack.

For critical applications, guides in wedge gate valves are machined to close tolerances and designed to carry the wedge over nearly the entire valve travel, as in the valves shown in Figure 3-42 and Figure 3-43.

In the valve shown in Figure 3-42, the wedge grooves are hard-faced and precision-guided on machined guide ribs welded to the valve body. The wedge is permitted in this particular design to be carried by the seat for 5% of the total travel.

In the valve shown in Figure 3-43, the wedge consists of two separate wedge-shaped plates. These carry hard-faced tongues that are guided in machined grooves of the valve body. When wear has taken place in the guides, the original guide tolerance can be restored by adjusting the thickness of a spacer ring between the two wedge plates.

Valve Bypass

Wedge gate valves may have to be provided with bypass connections for the same reason described for parallel gate valves on page 77.

Pressure-Equalizing Connection

In the case of wedge gate valves with a self-aligning double-seated wedge, thermal expansion of a fluid locked in the valve body will force the upstream and downstream seatings into still closer contact and cause the pressure in the valve body cavity to rise. A similar situation may arise with soft-seated wedge gate valves in which the wedge is capable of producing an upstream seat seal. Thus, if such valves handle a liquid with high thermal expansion, or if revaporation of trapped condensate can occur, they may have to be provided with a pressure-equalizing connection as described for parallel gate valves on page 77.

Case Study of Wedge Gate Valve Failure

Figure 3-46 through Figure 3-48 show components of a DN 300 (NPS 12) class 150 wedge gate valve to API standard 600 that failed on first application.

The valve was mounted in a horizontal line under an angle of 45° from the vertical for ease when hand-operating a gear drive. This operating position required the wedge to ride on the body rib. Unfortunately, the guide slot in the wedge had sharp edges. As the wedge traveled on the rib, the sharp edges of the guide slot caught on the rough rib surface, causing the wedge to rotate until contacting the opposite body rib. At this stage, the wedge was jammed. Further closing effort by the valve operator produced the damage to the valve internals shown in Figure 3-46 through Figure 3-48.

Figure 3-46 shows the damage to the wedge guide that was riding on the body rib and Figure 3-47 shows the damaged body rib. Figure 3-48

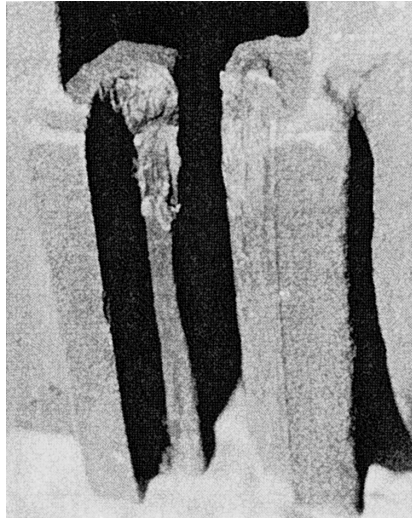

Figure 3-46. Damage to Guide Slots of Flexible Wedge Resulting from Attempted Closure of Wedge Gate Valve with Wedge Rotated and Jammed in Valve Body, Size DN 300 (NPS 12) Class 150. (Courtesy of David Mair.)

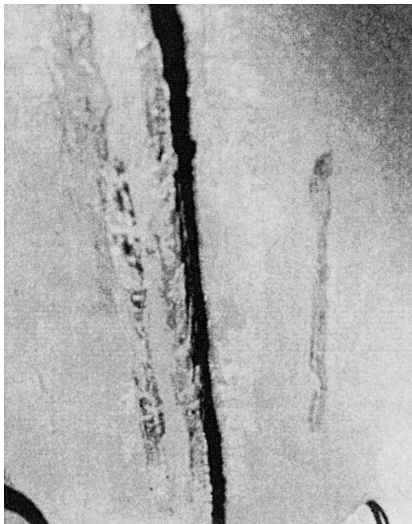

Figure 3-47. Damage to Valve Body Guide Ribs Resulting from Attempted Closure of Wedge Gate Valve with Rotated Wedge Jammed in Valve Body, Size DN 300 (NPS 12) Class 150. (Courtesy of David Mair.)

shows the bent valve stem and damage to the stem surface around the stem guide bush.

Further inspection of the valve showed also that play in the wedge guides was larger than the possible travel of the wedge on the stem. Thus, the stem had to carry the wedge for part of its travel in a tilted position. Furthermore,



Figure 3-48. Bent Valve Stem with Damage to Stem Surface Resulting from Attempted Closure of Wedge Gate Valve with Wedge Rotated and Jammed in Valve Body, Size DN 300 (NPS 12) Class 150. (Courtesy of David Mair.)

the lengths of body rib and wedge guide were far too short to adequately support the wedge during all stages of travel.

This valve failure was not isolated but was typical for a high percentage of all installed wedge gate valves. Finally, all suspect valves had to be replaced prior to start-up of the plant.

Standards Pertaining to Wedge Gate Valves

Appendix C provides a list of U.S. and British standards pertaining to wedge gate valves.

Applications

Duty:

Stopping and starting flow

Infrequent operation

Service:

Gases

Liquids

Rubber-seated wedge gate valves without bottom cavity for fluids carrying solids in suspension