



**PDHonline Course M322 (7 PDH)**

---

# **HVAC Equipments and Systems**

*Instructor: A. Bhatia, B.E.*

**2020**

**PDH Online | PDH Center**

5272 Meadow Estates Drive  
Fairfax, VA 22030-6658  
Phone: 703-988-0088  
[www.PDHonline.com](http://www.PDHonline.com)

An Approved Continuing Education Provider

# HVAC Equipments and Systems

*A. Bhatia, B.E.*

The field of heating, ventilation, and air conditioning—HVAC—is a science and practice of controlling indoor climate, thereby providing health and comfortable interior conditions for occupants in a well-designed, energy-efficient, and low-emissions manner.

The term "H" in HVAC stands for heating that comprises of any number of heating systems from gas furnaces, electric furnaces, oil furnaces, oil and gas boilers, radiant heating systems, and heat pumps.

"V" in HVAC describes ventilation. This can be ventilating the facility using ductwork or ventilating a kitchen using ductwork and fans with a hood. It can also refer to combustion air or the air needed to have combustion for various heating systems.

"AC" in HVAC refers to air conditioning that comprises of 3 main methods – mechanical compression, vapor absorption and evaporative cooling. Air conditioners (direct expansion – DX systems) and chillers usually accomplish the job of air conditioning.

## **Systems overview**

HVAC systems have the following elements in common:

- Equipment to generate heating or cooling: The equipment is selected with a capacity to offset the peak load of the space or spaces to be served.
- A means of distributing heat, cooling, and/or filtered ventilation air where needed: air, water, or steam.
- Devices that deliver the heat, cooling, and/or fresh air into the building: registers and diffusers, hydronic radiators or convectors, and fan coil units.

## **Heating and Cooling Equipment Performance Rating Terms**

A simple statement of efficiency is usually defined as "output divided by input at full load". But since, the HVAC equipment operates more often at off-peak (less than maximum

load) conditions, the term efficiency (at full load peak value) is deceptive. Seasonal efficiencies that consider a typical range of operating conditions and loads are more representative of the HVAC world. There are a number of ways to express the efficiency of a heating or cooling source.

- **COP – “Coefficient of Performance”** - is the measure chiller efficiency measured in Btu output (cooling capacity) divided by Btu input (electric power). Typical values are 2 – 4.
  - Cooling capacity is specified in tons of refrigeration; 1 ton is equivalent to 12000 Btu per hour.
  - 1 kWh of electric power is equivalent to 3412 Btu per hour; multiplying the COP by 3.412 yields energy efficiency ratio.
- **SEER – “Seasonal Energy Efficiency Ratio”** – Total cooling output of air conditioning equipment during normal operating season (in Btu per hour) divided by the total electric input during the same period in watt-hour. SEER ratings may range from less than 5 to more than 14. It applies to units of less than 65,000 Btu per hour capacity
- **EER – “Energy Efficiency Ratio”** – Equipment cooling capacity in Btu per hour divided by total energy input in watts at full-load conditions. The power input includes all inputs to compressors, fan motors, and controls. EER is always greater than one; typical values are 8 – 10. It typically applies to larger units over 65,000 Btuh capacity.
- **IPLV – “Integrated Part Load Value”** – A single number value that expresses part load efficiency of air conditioning equipment (based on EER or COP) weighed by operation at various part load capacities.
- **HSPF – “Heating Season Performance Factor”** – Total heating output of a heat pump during normal operating season in Btu divided by the total electric input during the same period in watt-hour. This rating is obtained by multiplying the COP of a heat pump by a factor of 3.412.

- **AFUE – “Annual Fuel Utilization Efficiency”** - Annual output energy of heating equipment divided by annual input energy in consistent units and including all pilot losses. Typical values are 80 – 85%.
- **Btuh – “British Thermal Units per Hour”** - is a rate of heating or cooling expressed in terms of Btu per hour. 1kW = 3412 Btu
- **Ton** – One ton of cooling is the heat extraction rate of 12000 Btu per hour. Theoretically it is energy required to melt one ton of ice in one hour.

Appropriate system selection, skillful design, commissioning, and proper operation and maintenance practices will also play a major role in system efficiency.

- Federal law mandates a minimum efficiency of 13 SEER for unitary equipment of less than 65,000 Btu per hour capacity. It is often cost effective to pay for more efficient equipment. For example, upgrading from a 13 SEER to a 14 will reduce cooling costs by about 7 percent.
- The American Society of Heating, Refrigeration and Air Conditioning Engineers (ASHRAE) recommend 10 EER for equipment between 65,000 and 135,000 Btu per hour. ASHRAE standard 90.1 recommends other efficiencies for larger equipment.
- The cooling efficiencies of package units under 250,000 Btu/hr are certified according to standards published by the Air Conditioning and Refrigeration Institute (ARI). ARI standards also apply to units of 250,000 Btu/hr and over, but ARI has no certification program and does not publish efficiency data for this size range.

We will learn more on the modern HVAC equipment and performance parameters later in this course. This course comprises 8 sections:-

**SECTION #1**                      Central Heating Sources - Provides an overview of various types of heating systems available for commercial and residential applications such as furnaces, boilers and heat pumps. Includes basic selection criteria for heating system and factors considered when designing commercial heating systems.

- SECTION # 2      Central Cooling Sources- Provides an overview of various cooling equipments such as mechanical chillers, absorption chillers, DX units, evaporative cooling and cooling towers.
- SECTION # 3      HVAC Delivery Equipment - Provides an overview of various heating and cooling delivery equipments such as convective and radiation baseboard units, air handling units, unitary units, fan coil units and their components.
- SECTION # 4      Air Distribution Ductwork – Provides an overview of air movement, components of air distribution systems, duct classification on velocity, pressure, shape and materials.
- SECTION # 5      Air Distribution Equipment & Accessories – Provides an overview of air delivery devices such as registers, grilles and diffusers. Covers other terminal devices such as dampers, louvers etc
- SECTION # 6      System Design - Provides an overview of “all-air” and “all-water” systems. Describes constant air volume, variable air volume, single duct and multi-duct air conditioning systems.
- SECTION # 7      Hydronic Distribution – Piping and Pumps – Provides an overview of the hydronic loops and the principles of centrifugal pumps.
- SECTION # 8      Annual Energy Use Calculations – Describes the concept of balance point temperature and heating and cooling degree days in determining annual energy costs.

## **SECTION– 1                      CENTRAL HEATING SOURCES**

Four distinctly different types of heat sources are employed in buildings. Heat may be generated by the combustion of some flammable material such as fuel oil or natural gas. Electricity may be converted to heat through the process of electric resistance. Solar radiation or other renewable energy resources may be collected on site and converted to heat. Heat may be removed from some material on site and transferred into a building. The choice of a heat source for a given building situation is usually based upon source availability, required system capacity, and the fuel/equipment costs.

Heating systems may be classified as **central** or **local**. Central heating system contains a boiler, furnace, or heat pump to heat water, steam, or air, all in a central location. The system also contains either ductwork, for forced air systems, or piping to distribute a heated fluid and radiators to transfer this heat to the air. Every area in the space is heated to the same temperature, which is controlled by a single thermostat. In local systems, all the 3 functions of heat generation, delivery and distribution are combined into a single package unit. In general central system is preferable for large buildings having multiple zones and local heating is a plus, if majority of areas remain unoccupied and if the people preferences require different temperatures or they disagree about the most comfortable temperature.

A brief discussion of some of the most commonly encountered heating and cooling sources is presented below.

### **FURNACE**

A furnace is a heating system component designed to heat air for distribution to various building spaces. All four heat source categories are used with furnaces, including on-site combustion (coal, oil, natural gas, propane), electric resistance, on-site energy collection (solar energy), and heat transfer (heat pumps). Regardless of the type of fuel the furnaces generally work on the same principle. The burning of fuel takes place inside an enclosed metal container (generally referred to as a fire box or heat exchanger), which warms the heat exchanger. The heat exchanger, now hot, radiates the heat into the air. This heated air is either circulated by density differential via a 'Gravity Furnace' or by aid of a blower via 'Forced air Furnace'.

**Gravity Furnace** - Small-capacity furnaces that rely on natural convection for heat distribution are classified as gravity furnaces. The term gravity refers to the fact that the furnace has no blower to move the heated air around the room. They rely on the fact that heated (less dense) air rises and the cooler (more dense) air falls to circulate the heat. This is not a very efficient way to heat a space and generally can effectively condition only one space.

**Forced Air Furnace** - Forced air furnaces are equipped with fans to circulate warm air over greater distance through a ductwork system. Cool return air from occupied spaces passes first through a filter, the blower, and the heating chamber, arriving at the supply ductwork at a raised temperature. The exhaust gases (including carbon-mono-oxide) are vented to the exterior of the building. The unit may also include a humidifier that evaporates moisture into the air as it passes through. Furnaces provide effective heating in smaller buildings where the longest duct run is less than 200 feet from the heat source. The life expectancy of furnace is 15 to 20 years.

**Furnace Efficiencies** – Efficiency of furnace is defined as the ratio of heat delivered to the energy input.

In HVAC parlance, the efficiency of small furnaces is expressed as annual fuel utilization efficiency (AFUE), which accounts for actual operating conditions. In addition to steady state efficiency, this factor also includes on-and-off cycling, the energy embodied in combustion air, and jacket losses. The minimum AFUE available is set by federal law for most furnace types at 78 percent. The highest AFUE units available are slightly less than 97 percent efficient.

In stores, you'll often hear furnaces being referred to as standard, mid and high efficient units. A standard furnace is one whose efficiency is below 70%, a Mid Efficient furnace is one whose efficiency is between 71% and 82% and a high efficient furnace is one with efficiency above 90%. The term 80% efficient - means that 80% of the heat energy is captured by your duct system. The remaining 20% escapes up the flue or emanates out the face of the furnace.

Old furnace: 100,000 BTU @ 60% efficient = 60,000 BTU of heat

New Furnace: 80,000 BTU @ 80% efficient = 64,000 BTU of heat

## Types of Furnaces

There are three types of furnaces: Single-Stage, Two-Stage, and Two-Stage Variable.

**Single-Stage** - Single stage implies the furnace fan control is simply "on and off". Since every space has a unique "heat load" which varies through out the day, the manufacturers wisely put options in the furnace fan speed.

**Two-Stage** - Two-Stage furnaces were developed with comfort in mind. Here is how they function. When the thermostat activates the furnace, it comes on at  $\frac{2}{3}$  rd strength (burning gas at 65% of maximum). If, after 10 minutes of operation, the thermostat is still calling for heat - the furnace will switch to 100%. What that accomplishes is a uniform heating of entire space. Two-Stage furnaces are more efficient and more effective way than single stage furnaces.

**Two-Stage Variable** - Two-stage variables furnace incorporates an additional feature of variable speed blower. In a single-stage furnace, the control is On-Off where as in the variable furnace, the fan turns over slowly and varies the air circulation per the load. This offers better energy efficiency.

## Furnace Configuration

**Up flow Furnace** - When a furnace is installed in a basement it is considered an "Up flow" furnace, meaning the cooler air is drawn at the base of the furnace, and the warm air exits out the top of the furnace.

**Down flow Furnace** - If a furnace is installed on the main floor of a home and the heat comes from floor registers, it is a "Down flow" furnace. In a down flow furnace, the cool air enters the furnace at the top and the warmed air exits at the bottom.

## Supply Air for Forced Furnaces (Typical Standard)

Equipment Type	Approximate Airflow Rate	Example
Gas/Oil Furnace	1 CFM per 100 Btu/hr output	64000 Btu/hr output furnace = 640CFM
Electric Furnace	50 – 70 CFM per	10kW furnace = 10 x 70 =



Equipment Type	Approximate Airflow Rate	Example
	kW input	700CFM 30kW furnace = 30 x 50 = 1500CFM

## HOT WATER & STEAM BOILER SYSTEMS

A boiler is a heating system component designed to heat water for distribution to various building spaces. As water can not be used to directly heat a space, boilers are only used in central systems where hot water is circulated to delivery devices (such as baseboard radiators, unit heaters, convectors, or air-handling units). Boilers are commonly designed to utilize two of the four basic heat sources: on-site combustion (coal, oil, natural gas, propane) and electric resistance.

There are three principal boiler categories: (1) natural draft v/s forced draft, (2) hot water v/s steam, and (3) fire in tube v/s water in tube.

In a **natural draft boiler**, the combustion air is drawn in by natural convection and therefore there is little control over the air/fuel ratio.

For **forced draft boilers**, the quantities of combustion air and air/fuel mixture are controlled by a blower.

Smaller commercial buildings use **hot water boilers** where water is heated to appropriate distribution temperatures (typically 140 - 180°F). These systems are often "**closed**" with virtually no fresh water makeup. Hot water boilers are often preferred because they normally do not need an operator or special water chemistry, and they run at higher fuel conversion efficiencies than steam boilers.

**Steam boilers** are found in many different configurations, but all serve one purpose: to contain water and transform it into steam by the application of heat. Steam boilers may be low pressure (approximately 15 psi), medium pressure (15 to 150 psi), or high pressure (150 to 500 psi).

Finally, boilers may be fire in tube or water in tube boilers.

**Fire Tube Boilers** - In fire tube boilers, hot combustion gases pass through tubes submerged in water. Typically, fire tube boilers do not exceed 25 million Btu/hr (MMBtu/hr) but capacities up to 70 MMBtu/hr are available. Fire tube boilers are prone to fouling. Boiler tube turbulators should be installed in fire tube boilers that can increase the boiler efficiency by 1.5 percent.

**Water Tube Boilers** - In water-tube boilers, the water is contained in tubes located inside a furnace and hot flue gases pass over the tubes, heating the water, and then exit out the stack. Sizes for packaged water tube boilers range from small, low pressure units (e.g., around 10 MMBtu/hr) to very large, high-pressure units with steam outputs of about 300 MMBtu/hr.

### **Combustion Process**

In order to understand the basics of efficient heating operation, the combustion process must be understood.

**Combustion** is the release of energy in the form of heat through the process of oxidation. The energy is stored in the bonds of carbon based fuels that are broken down during combustion. To make the combustion happen three inputs are necessary: fuel, oxygen, and a source of ignition. If the combustibles themselves can provide this third element as they burn, the source of ignition can be turned off. The products of complete combustion are heat energy, carbon dioxide, water vapor, nitrogen, and other gases (excluding oxygen).

In theory, there is a specific amount of oxygen that will completely burn a given amount of fuel – this is called “**stoichiometric**” air. In practice, burning conditions are never ideal and therefore, more air must be supplied to completely burn all the fuel. The amount of air above the theoretical requirement is referred to as “**excess air.**”

### **Why excess air?**

If an insufficient amount of air is supplied to the burners, unburned fuel, soot, smoke, and carbon monoxide are exhausted out the boiler stack. This results in fouling of heat transfer surfaces, pollution, lower combustion efficiency, flame instability (the flame blows out) and the potential for an explosion. To avoid these costly and unsafe conditions, boilers are normally operated at some **excess air level**. Typical optimum

values of excess air levels differ with the fuel type and are shown below for various boiler types. [Note - the equivalent percentage of oxygen by volume is shown in the table as well].

### Optimum Excess Air Levels

Fuel Type	Optimum Excess Air	Equivalent % O <sub>2</sub>	Equivalent % CO <sub>2</sub>
Natural Gas	5 – 10%	1 – 2%	10.5%
Propane	5 – 10%	1 – 2%	11 – 11.5%
No. 2 Oil	15 – 20%	3.5 - 4%	11.5 – 12%
No. 4 Oil	15 – 20%	3.5 - 4%	12.5 – 13%

Note the word optimum excess air. Any thing higher than this established optimum values will increase flue gas heat losses and consequently lower boiler efficiency. Minimizing these losses requires a routine monitoring of two variables: the **percentage of O<sub>2</sub> (or CO<sub>2</sub>)**, and the **stack temperature**. The most efficient and cost-effective use of fuel takes place when the CO<sub>2</sub> concentration in the exhaust is maximized and the O<sub>2</sub> concentration is minimized. Typically 1% efficiency loss occurs with every 40°F increase in stack temperature.

It is important to note that "excess air" and "excess oxygen" is not the same. Because air is roughly 21% oxygen by volume, 50% excess air is approximately equal to 10% oxygen remaining in the boiler exhaust stack.

The following formula is normally used to calculate the excess air:

$$\% \text{ Excess Air} = \frac{\% \text{O}_2 \text{ measured}}{20.9 - \% \text{O}_2 \text{ measured}} \times 100$$

### Boiler Efficiency

As fuel is such a dominant cost factor, the boiler efficiency needs to be kept high to keep operating costs low. In generic terms, boiler efficiency is a measure of - how much of the heating value of the fuel is being converted to useful heat.

### **Efficiency of a boiler = heat delivered/energy input**

The term “boiler efficiency” is often substituted for thermal efficiency or fuel-to-steam efficiency. Both are not same. Let’s see some efficiency reporting terms:

**Combustion Efficiency** - Combustion efficiency is an indication of the burner’s ability to burn fuel completely without generating carbon monoxide or without un-burnt carbon. Complete combustion efficiency would extract all the energy available in the fuel. However 100% combustion efficiency is not realistically achievable. Common combustion processes produce efficiencies from 10% to 95%. Combustion efficiency calculations assume complete fuel combustion and are based on three factors:

- The chemistry of the fuel -combustion efficiency is not the same for all fuels and, generally, gaseous and liquid fuels burn more efficiently than solid fuels.
- The net temperature of the stack gases – higher the temperature lower the efficiency
- The percentage of oxygen or CO<sub>2</sub> by volume after combustion – well designed burners firing gaseous and liquid fuels operate at excess air levels of 15% and result in negligible unburned fuel.

**Thermal Efficiency** – Thermal efficiency is a measure of the effectiveness of the heat exchanger of the boiler. It is solely a measurement of the effectiveness of the heat exchanger of the boiler and does not account for radiation and convection losses due to the boiler’s shell, water column, or other components. It is therefore not a true indication of the boilers fuel usage and should not be used in economic evaluations.

**Fuel to Steam Efficiency** – Fuel-to-steam efficiency is a measure of the overall efficiency of the boiler. It accounts for the effectiveness of the heat exchanger as well as the radiation and convection losses.

### **High Efficiency Boilers**

**Condensing boilers** – A condensing boiler preserves energy by using heat exchangers designed to remove additional energy from the gases of combustion before leaving the stack. The flue gases produced from condensing boilers are at a much lower temperatures than those of non condensing boilers to the extent that the water vapor in the flue gases condenses, thus releasing their latent heat and increasing efficiency of the boiler. Condensing boilers have efficiencies of 95% or greater as compared to the normal 70%-80% for non-condensing boilers.

Condensing boilers are typically available in sizes from 500,000 to 2,000,000 Btu per hour (15-60bhp). These are NOT available in larger sizes. To accommodate larger heating loads, multiple condensing boilers can be installed.

## **HEAT PUMP**

A heat pump is a device that acts as an air conditioner in the summer and as a heater in the winter. Heat pumps look and function exactly like an air conditioner except it has a reversible cycle. It contains a 4-way reversing valve that lets it switch between "air conditioner" and "heater."

For climates with moderate heating and cooling needs, heat pumps offer an energy-efficient alternative to furnaces and air conditioners. This unit works by moving existing heat from one area to another in one of the following ways:

**Air-to-air** - Uses air as the outdoor source of heating or cooling and delivers heating or cooling to air indoors. A condenser absorbs heat from the outdoor air (even the coldest air contains some heat) and transfers it to an indoor heat exchanger. Indoor air is warmed in the heat exchanger and circulated throughout the interior space. During the summer, the process is reversed to cool and dehumidify the home.

**Water-to-air** - Uses water as the source of heating/cooling, delivers heating/cooling to air indoors. Instead of extracting heat from outside air, this type of pump absorbs heat from ground water or surface water, such as a farm pond.

**Air-to-water** - Uses air outside, water inside: useful where there is a demand for hot water as well as for air cooling and dehumidification).

**Ground-to-air:** Also known as a geothermal system, this type of heat pump uses underground loops to absorb heat from the earth. Geothermal systems are usually installed in newly-built homes, but can also be used in existing home.

One advantage of a heat pump is that it provides both heating and cooling capabilities in one unit. Electric heat pumps are usually supplemented with a backup system, such as radiant floor heaters or baseboard units, in case of extended periods of extreme low ambient temperatures.

### **Heat Pump Efficiency**

Because heat pumps move heat rather than generating heat, these can provide up to 4 times the amount of energy they consume. If you heat with electricity, a heat pump can trim the amount of electricity you use for heating by as much as 30% to 40%. High-efficiency heat pumps also dehumidify better than standard central air conditioners, resulting in less energy usage and more cooling comfort in summer months.

The measurement of heating efficiency of a heat pump is the coefficient of performance (COP). It is the ratio of heat output to electricity input using the same units (BTUH or kW). A heat pump delivers from 1½ to 3½ units of heat for every unit of electricity it uses; saves from 30 to 60 per cent electric heating bills, depending on the geographic location and equipment used. COP of a heat pump is generally greater than 1. Heat output of a heat pump, in terms of BTUH per kWh, is a product of its COP and a factor of 3400 (e.g. if the COP of a heat pump is 1, then its heat output would be  $1 \times 3400 = 3400$  BTUH per kWh).

The heating efficiency of a heat pump may also be measured using a rating known as HSPF (Heating Season Performance Factor). This rating is obtained by multiplying the COP of a heat pump by a factor of 3.4.

### **LOCAL HEATING SOURCES**

A local heating system serves a single thermal zone and has its major components located within the zone itself. Serving only a single zone, local heating systems will have only one point of control -- typically a thermostat for active systems. A local heating system will consist of one or more self-contained equipment units containing heat source, distribution, and delivery functions in a single package. Portable electric heaters, built-in

electric resistance heaters, electric resistance baseboard radiators, infrared heaters, fireplaces, and wood stoves are examples of local heating-only systems.

There are a number of **advantages** associated with the use of local systems.

- Local systems tend to be distributed systems; a building conditioned using local system may have a dozen (or a hundred) individual and independent units located throughout the building. Distributed systems tend to provide greater collective reliability than do centralized systems. The failure of one of 12 heating units, for example, may cause discomfort in one room of a building but there are still 11 operating units that can provide heat for the rest of the building.
- Because local systems are likely to be of small capacity and are not complicated by interconnections with other units, maintenance of local systems tends to be simple and available through numerous service providers.
- In a building where a large number of spaces may be used only on an occasional basis, such as a dormitory or hotel, local systems may be totally shut off in the unused spaces, thus providing potential energy savings.
- A local HVAC system may provide greater occupant comfort through totally individualized control options -- if one room needs heating while an adjacent one needs cooling, two local systems can respond without conflict.

With advantages often come **disadvantages**.

- Local system units can not be easily connected together to permit centralized energy management operations.
- Local systems can usually be centrally controlled with respect to on-off functions through electric circuit control, but more sophisticated central control (such as night-setback or economizer operation) is not possible.
- Local systems can not benefit from economies of scale. The efficiency of equipment generally increases with capacity; as each local unit is normally of low capacity; local system efficiency is relatively low.

- Lack of interconnection between units also means that loads can not be shared on a building-wide basis. Several central HVAC systems deliver improved efficiency and lower first cost by sharing load capacity across an entire building.
- Although local system maintenance may often be relatively simple, such maintenance may have to occur directly in occupied building spaces.

**Heating costs:**

- **Electric heating:** First cost is low, but very expensive to operate.
  - **Heat pumps:** Operating costs are much lower than electric heating, but initial cost is high.
  - **Gas and oil:** Initial and operating costs of furnaces/ boilers using gas or oil can be competitive with those of heat pumps.
-



## SECTION – 2 HVAC EQUIPMENT: COOLING SOURCES

### General

The process of cooling is actually removal of heat. Comfort cooling is almost always accomplished by cooling air and then distributing the air into the space, where it mixes with the room air and cools down the entire volume.

### Processes of cooling

There are four principal processes of cooling: a) mechanical compression refrigeration, b) absorption refrigeration, c) evaporative cooling, and d) natural ventilation. Cooling processes almost always involve circulating air through a machine that cools air down and blows it with a fan back into the space to be conditioned. The fluid that imparts the cooling effect to air is either a refrigerant--which changes from a liquid to a gas--or water. The central cooling generation equipment is referred to as **DX (direct expansion)** when the fluid used is a refrigerant. If the fluid is water, then the equipment called **water chiller**.

### MECHANICAL COMPRESSION REFRIGERATION

The mechanical vapor-compression cycle is a method of transferring heat from one location to another. The cycle consists of four basic components: **a) evaporator, b) compressor, c) condenser, and d) expansion valve.**

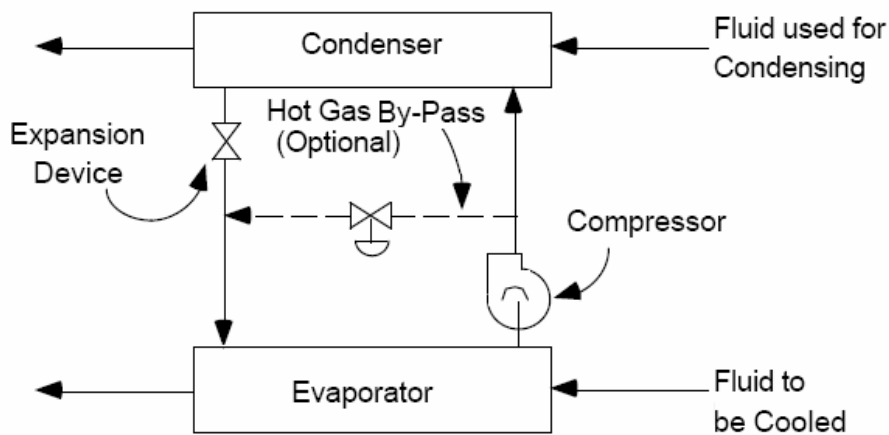

**Mechanical Compression Refrigeration System**

## Evaporator

An **evaporator** is a heat exchanger in which the liquid refrigerant is vaporized and extracts heat from the surrounding air, chilled water, brine, or other substance to produce a refrigeration effect. Evaporators used in air-conditioning can be classified according to the combination of the medium to be cooled and the type of refrigerant feed; broadly 2 types are used in comfort applications:

- Direct expansion DX coils are air coolers, and the refrigerant is fed according to its degree of superheat after vaporization. DX coils were covered earlier.
- Flooded shell-and-tube liquid coolers is similar in construction to a shell-and-tube water-cooled condenser, except that it's liquid refrigeration inlet is at the bottom and the vapor outlet is at the top. Water velocity inside the copper tubes is usually between 4 and 12 ft/sec and the water-side pressure drop is normally below 10 psig. Flooded liquid coolers can provide larger evaporating surface area and need minimal space. They are widely used in large central air-conditioning systems.

## Compressor

The **compressor** compresses the refrigerant gas, causing it to become much warmer than the outside air. The refrigerant enters the compressor on the "suction side" and after it leaves the compressor, the refrigerant is referred to as "hot gas". Four types of electrical chillers dominate the market:

- **Reciprocating Compressors** - Reciprocating compressors are driven by a motor and use pistons, cylinders and valves to compress the refrigerant. Reciprocating compressors are usually used in smaller systems up to 100 tons and are available in hermetic, semi-hermetic or externally driven versions. In a hermetic unit, the motor and compressor are enclosed in a common housing, which is sealed. Refrigerant R-22 is widely used in comfort systems. Capacity control of reciprocating compressor including: on-off and cylinder un-loader in which discharge gas is in short cut and return to the suction chamber.

- **Scroll compressors** - Scroll compressors features two involute scrolls, one stationary and one orbiting around the first. This movement draws gas into the outer pocket and the gas is forced toward the center of the scroll, creating increasingly higher gas pressures. The upper limit of the refrigeration capacity of currently manufactured scroll compressors is 60 tons. A scroll compressor also has only about half as many parts as a reciprocating compressor at the same refrigeration capacity. Few components result in higher reliability and efficiency. Power input to the scroll compressor is about 5 to 10% less than to the reciprocating compressor. A scroll compressor also operates more smoothly and is quieter.
- **Screw compressors** - Screw compressors are based on a mechanism made up of two threaded rotors (screws) that are coupled together. The gas is compressed due to the progressive overlapping of the lobes, causing a reduction in the volume occupied by the gas. Continuous and step-less capacity control is provided by moving a sliding valve toward the discharge port, which opens a shortcut recirculating passage to the suction port.

The refrigeration capacity of twin-screw compressors is 50 to 1500 tons but is normally used in the 200 tons to 800 tons range. Twin-screw compressors are more efficient than reciprocating compressors and are equipment of choice especially at large ratings and air-cooled options.

- **Centrifugal compressors** - Centrifugal compressors are made up of a rotor located inside a special chamber. The rotor is rotated at high speed, imparting high kinetic energy to the gas, which is forced through the narrow outlet opening, thus increasing its pressure. The characteristics of a centrifugal compressor make it ideal for air conditioning applications because it is suitable for variable loads, has few moving parts, and is economical to operate. The power requirement of the centrifugal compressor is about 0.75 kW/ton when 45°F chilled water is produced and modern machines of larger capacities go down to as low as 0.48 kW/ton. The available refrigeration capacity for centrifugal compressors ranges from 100 to 2,000 tons. Centrifugal compressors have higher volume flow per unit refrigeration capacity output than positive displacement compressors. They are the most widely used refrigeration

compressors in large air-conditioning systems but are used ONLY in water cooled configurations due to lower compression ratios.

## Condenser

A **Condenser** is a heat exchanger in which hot gaseous refrigerant is condensed into liquid and the latent heat of condensation is rejected to the atmospheric air, surface water, or well water. In a condenser, hot gas is first de-superheated, then condensed into liquid, and finally sub-cooled. Condensers can be either air-cooled or water-cooled.

- **Air cooled condensers** - As the name suggests, these use ambient air to remove heat from the refrigerant. Hot gas from the compressor enters the condensing coil from the top. A fan forces air across small tubes containing the hot refrigerant and discharges that heat into the ambient air. The volume flow of cooling air per unit of total heat rejection is typically 600 to 1200 cfm/ton of refrigeration capacity and the optimum value is about 900 cfm/ton. The corresponding cooling air temperature difference — cooling air leaving temperature minus outdoor temperature is around 13°F.

Air-cooled condensers are rated at a specific condenser temperature difference CTD, depending on the evaporating temperature of the refrigeration system. The condenser temperature difference (CTD) for an air-cooled condenser is defined as the difference between the saturated condensing temperature corresponding to the pressure at the inlet and the air intake temperature. For a refrigeration system having a lower evaporating temperature, it is more economical to equip a larger condenser with a smaller CTD. For a comfort air-conditioning system having an evaporative temperature of 45°F; CTD = 20 to 30°F.

A higher condensing temperature, a higher condensing pressure, and a higher compressor power input may be due to an undersized air-cooled condenser, lack of cooling air or a high entering cooling air temperature, a dirty condensing coil, warm air circulation because of insufficient clearance between the condenser and the wall, or a combination of these. The clearance should not be less than the width of the condensing coil.

Compared to water, air is a poor conductor of heat and therefore air-cooled chillers are larger and less efficient. Air-cooled machines operate at higher compressor ratios – which mean less cooling per watt energy consumption.

- **Water cooled condensers** - Water condensed units are more efficient than air condensed, often operating in the range of 15 EER or better. Water cooled chillers require a source of cooling water, such as cooling tower water, to extract heat from the refrigerant at the condenser and reject it to the ambient environment. Two types of water-cooled condensers are widely used for air-conditioning and refrigeration: double-tube condensers and horizontal shell-and-tube condensers.
  - A **double-tube condenser** consists of two tubes, one inside the other. Condenser water is pumped through the inner tube and refrigerant flows within the space between the inner and outer tubes in a counter-flow arrangement. Because of its limited condensing area, the double-tube condenser is used only in small refrigeration systems.
  - A horizontal **shell-and-tube** water-cooled condenser using halocarbon refrigerant usually has an outer shell in which copper tubes typically 5/8 to 3/4 in. in diameter are fixed in position by tube sheets. Integral external fins of 19 to 35 fins/in and a height of 0.006 in. and spiral internal grooves are typically used for copper tubes to increase both the external and the inner surface area and their heat transfer coefficients.
- **Evaporative Condensers** - Another alternative to the air or water-cooled condensers is the evaporative condenser. Evaporative condensers are like cooling towers with built in heat exchangers. Refrigerant passes through a copper tube bundle in the evaporative cell. Water cascades over its outer surface and airflow counter to the flow of water causes some of the water to evaporate. This results in the efficient cooling of the refrigerant. There is a sump in the bottom of the condenser to store water and a pump draws the water to spray over the coils. In winters, the pump is de-energized and only the air flows across the coils just like air-cooled condenser.

### **Circumstances Favoring Air-Cooled or Water Cooled Condensers**

Capacity Range (TR)	Favorable System
40 to 200	Air-cooled chilled water system (explore the pros and cons of using multiple DX systems if possible)
200 and above	Water-cooled chilled water system

### Expansion Process

The final step in the refrigeration cycle is the expansion of the refrigerant in an expansion valve. This relieves the pressure built up by the compressor. Temperature is thus reduced even further allowing the refrigerant to absorb more heat from the interior space when it re-enters the evaporator. For large chillers, electronic thermostatic expansion valves are used as expansion device, whereas in smaller systems such as window air conditioners capillary tube is used.

### Refrigerants

A number of chemical compounds, commonly known as freon, are used as refrigerants. R-22, R-134, R404. chloroflorocarbons (CFC) refrigerants (R-11) were traditionally used in many centrifugal chillers, but is no longer produced as of 12/31/95 due to concerns of **ozone** depletion.

Most cooling equipment presently manufactured with hydro-chloroflorocarbons HCFC-22 is being or will be altered to Hydroflorocarbons HFC-134a, R-410A, or R-407C (R-410A and R407C are blends of HFC refrigerants). The new refrigerants help combat the growing ozone depletion in the earth's atmosphere, since they contain **no chlorine**.

### Current and Future Refrigerants

Equipment Type	Traditional Refrigerant	Replacement Refrigerants
Rotary Screw- Chiller	HCFC-22	R407C, HFC-134a
Scroll Chiller	HCFC-22	R407C, R-410A
Reciprocating Chiller	HCFC-22	R-407C, R-410A
Absorption Chiller	R-718 (water)	R-718
Centrifugal Chiller	CFC-11, CFC-12	HFC-134a, HCFC-123
Packaged Air Conditioners	HCFC-22	R-407C, R-410A
Heat Pump	HCFC-22	R407C, R-410A
PTAC, PTHP	HCFC-22	R-407C, R-410A
Room Air Conditioning	HCFC-22	R-407C, R-410A

### Direct expansion (DX)

When the air is cooled directly by passing it over an evaporator in which the refrigerant is expanding from a liquid to a gas, the process is known as direct expansion. Suitable only for small systems; window air-conditioners, package units and split systems are typical examples of DX systems. The application and unit capacity ranges are as follows:

- Room air conditioner (capacity range of 0.5 to 3 TR per unit, suitable for an area of not more than 1000 square feet)
- Packaged unit integral air-cooled condenser (capacity range of 3 to 50 TR, suitable for a maximum an area of 1000 – 10000 square feet)
- Split system with outdoor air-cooled condenser (capacity range of 0.5 to 50 TR, suitable for an area of 100 – 10000 square feet)

Multiple DX units are often used for larger buildings.

### Unitary Heat Pumps and Air Conditioners

The most common types of air conditioning equipment are unitary air conditioners and heat pumps. “Unitary” refers to the fact that all of the components necessary to heat, cool, dehumidify, filter and move air are included in one or more factory-made assemblies. These equipments are available as single package or as split systems.

- Single package units include all of the necessary functions and components in one package that is installed outside the building.

- Split systems are made up of an indoor unit (fan and cooling/heating coils) and an outdoor unit (condenser and compressor).
- Unitary equipment includes heat pumps and air conditioners with integral or separate gas or electric heating systems.
- Heat pumps provide both heating and cooling from the same unit and are the most efficient devices.
- Air conditioners provide cooling only and must be supplemented with either an internal electric or gas-heating coil or with a totally stand-alone heating system.

### **Chillers**

A water chilled system has to be used for larger buildings. In such a system, the entire refrigeration cycle occurs within a single piece of equipment known as a chiller. An electrically driven water chiller uses the same vapor-compression refrigeration as a DX system. But instead of cooling air, it chills water which is pumped to the air handling units.

The most effective chiller is primarily a function of chiller size and in general the following guidelines apply:

- Up to 25 tons (88kW) – Reciprocating
- 25 to 80 tons (88 to 280kW) – Reciprocating or Screw
- 80 to 200 tons (280 to 700kW) – Reciprocating, Screw or Centrifugal
- 200 to 800 tons (700 to 2800kW) – Screw or Centrifugal
- Above 800 tons (2800 kW) – Centrifugal

\* Note centrifugal chillers work only with water cooled condenser.

### **Chiller Tonnage Output**

The following equation calculates the refrigeration output in Tons of a chiller:



$$\text{Tons} = \text{GPM} * (\text{T1} - \text{T2}) / 24$$

Where

- T1 = Chilled water return temperature in degrees F
- T2 = Chilled water supply temperature in degrees F
- GPM = Volume of water passing through the chiller

### Chiller Coefficient of Performance (COP)

The following equation calculates the coefficient of performance of a chiller:

$$\text{COP} = (\text{T1} - \text{T2}) * \text{GPM} * 500 / (3412 * \text{kW})$$

Where

- T1 = Chilled water return temperature in degrees F
- T2 = Chilled water supply temperature in degrees F
- GPM = Volume of water passing through the chiller
- kW = Kilowatts

### Converting kW/Ton to COP or EER

If a chiller's efficiency is rated at 1 kW/ton, the COP=3.5 and the EER=12

kW/ton	=	12 / EER
kW/ton	=	12 / (COP x 3.412)
EER	=	12 / (kW/ton)
EER	=	COP x 3.412
COP	=	EER / 3.412
COP	=	12 / (kW/ton x 3.412)

### Chiller performance ratings

ASHRAE Standard 90.1 establishes minimum energy efficiency levels for chillers.

Equipment Type	Size Category	ASHRAE 90.1-2001 (kW/ton)	
		Full Load	IPLV
Air cooled w/ condenser	All	1.26	1.15
Air cooled w/o condenser	All	1.13	1.02
Water cooled, reciprocating	All	0.84	0.70
Water cooled, rotary screw, and scroll	< 100 tons	0.72	0.63
	<sup>3</sup> 100 tons and < 150 tons	0.72	0.63
	<sup>3</sup> 150 tons and ≤ 300 tons		
	> 300 tons	0.64	0.57
Water cooled, centrifugal	< 150 tons	0.70	0.67
	<sup>3</sup> 150 tons and ≤ 300 tons	0.63	0.60
	> 300 tons and ≤ 600 tons	0.58	0.55
	> 600 tons		

Various chiller designs have different full load efficiencies and part load efficiencies (IPLV). Since chillers are typically sized to meet design heating and cooling conditions that historically occur only 1% to 2.5% of the time, the part-load performance of chiller (IPLV rating) is a critical consideration HVAC sizing. Simply selecting a high-efficiency chiller at full load does not guarantee high performance. Instead, compliance with both the full load efficiency numbers and IPLV numbers is required.

Few important strategies for selecting and improving chiller plant load efficiency include:

- **Peak load** demand determines the overall capacity of the system. The total chiller capacity in tons of refrigeration shall match the peak building load.
- **Part load** requirements determine the number and size of chillers required. Cooling load profile will help to determine the type of chiller to use and if single or multiple chillers should be installed. Multiple chiller installations allow facilities

professionals to stage their operation to match building loads while keeping the chillers operating at energy efficient loading.

- **Standby strategy** - Adopt standby or (N+ 1) strategy. The provision of 1 additional back up unit is known as N+1 strategy. The applications where cooling is required for critical service delivery, one back up unit would be required.

### **Chiller Energy Efficiency Options**

- **Reduce condenser water temperature** - Chiller energy consumption is a function of the condenser pressure and temperature. Lowering the condenser water temperature reduces the refrigerant condensing temperature and condensing pressure. Energy savings, at full-load, will be 1 to 2% per degree of reduction in entering condenser water temperature.
- **Raise chilled water supply temperature** - Raising the chilled water temperature lowers the compressor head, resulting in decreased energy consumption. For centrifugal chillers at constant speed, this strategy saves 0.5% to 0.75% per degree of reset at full load operation. [Note that the efficiency will drop at operating loads of 40% and less].
- **Variable speed drive options** - The use variable speed drives greatly enhances energy efficiency. This enables the chiller to match the speed of the compressor to the load at the maximum efficiency. It also allows the chiller to function, without damage, at much lower condenser water temperatures.
- **Variable chilled water flow thru chillers** - The variable flow chillers vary the volume of chilled water flow per demand. The system design makes use of two loops of primary and secondary distribution, each equipped with variable speed pumps to deliver chilled water per demand. Carefully designed variable flow chillers offer 5 to 10% energy savings but cautions needed to ensure minimum flow circulation through the bypass line.
- **Chiller Plant Automation, Reporting, and Control** – Direct digital controls compatible with building management systems improve level of monitoring and

reliability. A well-designed automation package can greatly reduce the energy consumption.

- **Demand Limiters and Staggered Start** – Since peak demand occurs during chiller startup; the most severe demand usually occurs on a hot summer morning when chillers are started and the system water is warm. Demand limiters enable the multiple chiller installations to stagger their start. The second chiller is started only after the first is loaded.

## **ABSORPTION REFRIGERATION**

### **Absorption chiller**

Absorption chillers are heat-operated devices that use thermal energy to produce chilled water. The basic difference between the electric chillers and absorption chillers is that an electric chiller uses an electric motor for operating a compressor whereas an absorption chiller uses thermal heat for compressing refrigerant vapors to a high-pressure.

Absorption process occurs in two vessels---one containing a generator and a condenser and the other containing an evaporator and an absorber. Normally refrigerant used in this process is **water** under low pressure. This refrigerant absorbs heat from the medium to be cooled and is vaporized in the process. The cool vapor is then absorbed by the salt solution (usually lithium bromide) in the absorber. The weak salt solution in the absorber is pumped to the generator in order to make it stronger; it is then circulated back to the absorber. Water is boiled out of the solution in a distillation process in the generator. The resulting water vapor passes into the condenser section where a cooling medium is used to condense the water back to a liquid state. The water then flows to the evaporator section where it passes over tubes containing the fluid to be cooled. Due to low pressure, water in the evaporator boils at a low temperature.

The two most common refrigerant/ absorbent mixtures used in absorption chillers are **water/lithium bromide** and **ammonia/water**.

Absorption chillers can be direct-fired, using natural gas or fuel oil, or indirect-fired using steam from a boiler or steam generated from waste heat recovery from the exhaust of

furnace, boilers or power-generation equipment (e.g. turbines, micro-turbines, and engines).

Absorption chillers come in two commercially available designs: **single-effect** and **double-effect**.

- Single-effect machines provide a thermal COP of 0.7 and require about 18 pounds steam per ton-hour of cooling at low pressure of 15 psig.
- Double-effect machines are about 40% more efficient, but require a higher steam pressure of about 100 – 150 psig. These machines use lower quantity of steam of about 10 lbs per ton.

Modern absorption refrigeration units range in capacity from about 100 tons to 1,600 tons for chilled water service. Most ratings are based on a minimum chilled water outlet temperature of 40°F, a minimum condenser water temperature of 70°F at the absorber inlet, and a generator steam pressure of 12 psig. Hot water or hot process fluids can be used in lieu of steam for the generator; however, the fluid inlet temperature must be at least 240°F for maximum capacity.

Absorption cooling may be worth considering if at least one of the following applies:

- When natural gas prices (used to produce steam) are significantly lower than electric prices or other alternate low-cost source of fuels is available
- When there is steam available from an on-site process; an example is steam from a turbine or where waste heat can be easily tapped
- When a steam plant is available but lightly loaded during the cooling season. Many hospitals have large steam plants that run at extremely low loads and low efficiency during the cooling season. By installing an absorption chiller, the steam plant efficiency can be increased significantly during the cooling season.
- When the design team and building owner wish to have fuel flexibility to hedge against changes in future utility prices.
- When the site has electric load limitation that is expensive to upgrade

Compared with mechanical chillers, absorption chillers have a low coefficient of performance (COP = chiller load/heat input). However, absorption chillers can substantially reduce operating costs because they are powered by low-grade waste heat.

### **Operating Problems**

Every effort must be made to keep the system air-tight, as even very small leaks can cause problems and are difficult to detect. Air entering the machine causes

- The lithium bromide solution to become highly corrosive to metals
- Lithium bromide solution to crystallize
- The chilled water temperature to increase
- Refrigeration capacity to decrease

Crystallization occurs when the lithium bromide solution does not go through the normal dilution cycle. When this happens, the solution becomes so concentrated that it crystallizes and plugs the solution lines. The unit must then be shut down and decrystallized. Crystallization can be caused by a power failure, controller malfunction, extreme variations in the condenser water temperature, or operator error in inadvertently allowing air to enter the machine. It is indicated by a rise in the outlet chilled-water temperature, a loss of solution pump (or a noisy solution pump), a loss of solution level in the absorber, and generator flooding.

Although absorption refrigeration machines are generally more difficult to operate and require more maintenance than mechanical refrigeration machines, they allow waste stream to be utilized more efficiently and in the proper application can result in substantial energy savings.

**Direct-Fired Two-Stage Absorption Refrigeration** - A recent development is the use of direct gas firing or waste heat as the energy source in lieu of steam. The gas stream must be 550°F for use in this application. Possible sources are drying ovens, heat-treating facilities, paint-baking ovens, process ovens, or any process which gives off a

clean, high temperature exhaust gas. A special advantage of this unit is that it can be directly integrated into a packaged cogeneration system.

## EVAPORATIVE COOLING

In hot dry climates, usable cooling effect may be obtained from the evaporative cooling process ; when a pound of water evaporates, almost 1000 Btu's of cooling is associated with the process.

Evaporative cooling is a basic psychrometric process in which air is sensibly cooled while it is simultaneously humidified. Sensible cooling results in reduction in dry bulb temperatures of air - If the process were 100% efficient, the temperature drop of the air would be the difference between dry bulb and wet bulb temperatures. In practice, efficiencies of 80-90% are routinely achieved.

Two terms are important here:

**Wet Bulb Depression** - The difference between the Dry Bulb and Wet Bulb temperatures, i.e. if Dry Bulb is 100 degrees (F) and the Wet Bulb is 70 degrees (F), the Web Bulb Depression is 30 degrees (F). The Wet Bulb Depression is used to determine the percent of efficiency of the cooling media.

**Cooling Efficiency** - The percent of the temperature drop across the media compared to the Wet Bulb Depression i.e. if the Wet Bulb Depression is 30 degrees (F) (as in the above example) and the actual temperature drop measured across the cooling media is 27 degrees (F), the cooling efficiency of the media is 90%. ( $27/30 = .90$ ). The cooling efficiency is also referred to as "Saturation Efficiency" because it refers to the amount of moisture that is packed into the air. 100% Saturation Efficiency would indicate a temperature drop of 30 degrees (F) in the above example of wet bulb depression.

Evaporative coolers provide cooling by blowing hot, dry air over a wetted pad and cooling the hot air by the process of evaporation. In doing so, the humidity of the air entering the conditioned space is increased.

The most common form of this technology is **direct evaporative cooling** otherwise known as a "swamp cooler." The effectiveness can reach 80% to 90% meaning that the dry bulb temperature drops 80% - 90% of the difference between the dry bulb and wet

bulb temperature of the entering air. For example, if entering air temperature is 80°F dry bulb and 50°F wet bulb, then the leaving air is cooled to 56°F dry bulb at 80% effectiveness and 53°F dry bulb at 90% effectiveness.

Another form is **indirect evaporative cooling** that eliminates the problem of increasing the humidity level of the air by using a heat exchanger. Indirect evaporative cooling is not as effective as direct evaporative cooling, but adds no moisture to the supply air. Indirect evaporative cooling can be approximately 60% effective in reducing the dry bulb temperature of the entering air to its wet bulb temperature. While direct cooling provides 53°F to 56°F air in the example above, indirect cooling could provide 62°F air.

**Indirect/direct** systems that combine these two approaches to improve effectiveness while limiting humidity are also available.

The system works only in hot-arid climatic conditions.

## COOLING TOWERS

A cooling tower is a heat rejection device, installed outside of the building envelope, through which condenser water is circulated. Refrigerant in the refrigeration cycle is condensed in a refrigerant-to-water heat exchanger. Heat rejected from the refrigerant increases the temperature of the condenser water, which must be cooled to permit the cycle to continue. The condenser water is circulated to the cooling tower where evaporative cooling causes heat to be removed from the water and added to the outside air. The cooled condenser water is then piped back to the condenser of the chiller. A cooling tower is a latent heat exchanger, where the magnitude of heat flow is a function of the quantity of water that is evaporated -- which is primarily a function of the relative humidity of the outside air.

Cooling Towers for HVAC duty are usually described by their tons of cooling capacity. The cooling capacity indicates the rate at which the cooling tower can transfer heat. One ton of cooling is equal to 12,000 BTUs (British thermal units) per hour, or 200 BTUs per minute. The heat rejected from an air conditioning system equals about 1.25 times the net refrigeration effect. Therefore the *equivalent ton* on the cooling tower side actually rejects about 15,000 Btu/hour (12000 Btu cooling load plus 3000 Btu's per ton for work of compression). Cooling tower capacities at commercial, industrial, or institutional



facilities typically range from as little as 50 tons to as much as 1,000 tons or more. Large facilities may be equipped with several large cooling towers.

Typically, cooling tower systems capacity are rated to lower 95°F water to 85°F at 78°F wet bulb. Wet-bulb temperature of the air is the lowest temperature possible for evaporation due to ambient or surrounding environment so the temperature of the water cannot drop below the prevailing wet bulb temperature of the air. The difference of EWT to LWT is termed “**range**” of cooling tower. This is usually 10°F in HVAC industry. The difference in LWT and the ambient wet bulb temperature is termed “**approach**” of the cooling tower. Cooling towers should be engineered for a 3° F - 5° F wet bulb temperature approach. Lowering the approach further down implies the cooling tower shall be larger and will increase costs.

There are three basic types of towers.

**Forced Draft Tower** - In forced draft cooling towers, air is "pushed" through the tower from an inlet to an exhaust. A forced draft mechanical draft tower is a blow-through arrangement, where a blower type fan at the intake forces air through the tower. A forced draft tower has a sensor that monitors the process water temperature after it exits from the tower. The fan engages or disengages when the process water temperature rises either above or below the desired set point.

**Induced Draft Tower** - A second type of tower, induced draft has a fan in the wet air stream to draw air through the fill. The fan located is located at the discharge end, which pulls air through tower.

Induced draft cooling towers are characterized as **Cross-flow** and **Counter-flow** designs, by virtue of air-to-water flow arrangement. The difference lies in the “fill” arrangement. In a counter-flow induced draft cooling towers, air travels upward through the fill or tube bundles, opposite to the downward motion of the water. In cross-flow induced draft cooling towers, air moves horizontally through the fill as the water moves downward.

**Natural Draft Tower** - A third type, natural draft tower, has no mechanical means to create airflow. Natural-draft cooling towers use the buoyancy of the exhaust air rising in a tall chimney to provide the draft. Warm, moist air naturally rises due to the density differential to the dry, cooler outside air.

Cooling water is susceptible to scale and corrosion over a period of time. To prevent formation of scale, water is treated prior to using it for coolant purposes. The water treatment methods are classified in three broad categories:

- Water Treatment (Softening, Dealkalization, Demineralization, Reverse Osmosis)
- Chemical dosing

Cooling towers shall be factory tested by licensed testing agency in accordance with CTI 201-96. The CTI certification is preferable over the field tests.

---

### SECTION-3

### HVAC DELIVERY EQUIPMENT

The heating or cooling effect produced at a source and distributed by a central system to spaces throughout a building needs to be properly delivered to each space to promote comfort. In air-based systems, heated or cooled air could theoretically just be dumped into each space. Such an approach, however, does not provide the control over air distribution. In water-based systems, the heated or cooled media (water or steam) can not just be dumped into a space. Some means of transferring the conditioning effect from the media to the space is required. Devices designed to provide the interface between occupied building spaces and distribution components are collectively termed delivery devices. A brief discussion of some common delivery devices is given below.

#### **Distributed Heat Devices at Local Zones**

In boiler fed or radiant heating systems, all but the simplest systems have a pump to circulate the water and ensure an equal supply of heat to all the radiators. The heated water can also be fed through another (secondary) heat exchanger inside a storage cylinder to provide hot running water. The term *radiator* in this context is misleading since most heat transfer from the heat exchanger is by **convection**, not **radiation**.

#### **Convective Heating Equipment**

- **Fin-tube radiator (FTR):** Warms room air by contact. Known as fin-tube radiators (FTR), these devices actually transfer heat to the air by convection rather than radiation. Heating element within the equipment are aluminum/copper fins bonded to copper tubing. Steam or hot water is circulated within the tubing.
- **Baseboard Heaters** - These units are installed along the base of a wall, and have relatively unrestricted length, providing a more distributed source of heat.
- **Duct Insert Heater** - Here electric heating elements are inserted in the ducts of forced air heating systems, either at the fan location or near supply air outlets. Heaters may be step-controlled in accordance with amount of heat needed. Automatic safety cut-offs interrupt current on either over-temperature of unit or fan failure.

- **Electric resistance units:** Electric resistance units have an electric element in place of the copper tubing and are independent from any central heat source. These are usually without a fan and work on natural convection. The elements are enclosed within a cabinet and are usually placed below the windows to warm the glass areas as well.
- **Unit heater:** A convection device that uses fan or blower to force air across a heating element and out into the room. This is factory-assembled unit with a fan and heating-mechanism enclosed within a casing. These may be suspended from roof or floor-mounted and are generally placed where major heat losses occur. Often used for spot heating in areas such as building entrances and where higher temperatures are needed.

### **Radiant Heating Equipment**

A radiant heating device provides heating by radiation. Radiant heat tends to be more comfortable than heated air. The radiant heating devices may be classified into three categories:

- **High temperature radiation:** These radiant devices, also known as infrared heaters, may be operated using electricity, gas, or oil. They rely on high temperatures to radiate heat from a relatively small area, heating all objects in their "line of sight," or radiation path. The units are usually mounted overhead facing toward the area to be warmed. Reflectors are used to direct the heat distribution pattern. Infrared heating is used in areas where heating the entire space through convection would be difficult or expensive in comparison to keeping people comfortable such as warehouses, garages, etc.
- **Medium temperature radiation:** These devices are large radiant panels that operate at temperatures somewhat lower than those of the infrared heaters. They are heated either using electrical resistance elements or by circulating hot water through pipes embedded in the panels. These panels can be mounted on the ceiling or walls. Electric radiant heating panels are available in a variety of sizes, typically ranging from about 2 feet by 2 feet up to 4 feet by 8 feet. Heating capacity is proportional to the panel area, with power densities varying from

about 50 to 125 watts per square foot (170 to 425 Btu per hour per square foot), depending on the manufacturer's specifications.

- **Low temperature radiation:** These systems use electrical elements, water piping, or ducts embedded in floor, walls, or ceiling and operate at near room temperature. The systems, constructed on site, are required to be well-insulated from the outside environmental conditions. This method of heating evenly distributes the heat source and produces a low temperature radiant heat surface. Hydronic slab heating systems using hot water through polyethylene or PEX pipes embedded in concrete have a major advantage over electric heating systems - they can provide cooling as well as radiant heating.

### **Distributed Cooling Equipment**

The essential elements of delivery side cooling and heating equipment are:

- **Air handling equipment:** Controls temperature, humidity, and quality of air.
- **Supply network:** Distributes conditioned air to different part of the building. Ducts required.
- **Return path:** Carries air back to the delivery unit (AHU). Ducting is optional.
- **Exhaust:** Required to get rid of odors and air contaminants.
- **Fresh air inlet:** Required to replace exhaust air and maintain an acceptable level of air quality.

### **Air handling unit (AHU)**

Both heating and cooling can be accomplished with the same equipment. Air quantity and duct sizes are usually set by summer cooling requirements. The unit is made up of fan(s) or blower(s), filter(s), heating coil(s), cooling coil(s), and a drain pan, all within an enclosure. An AHU either comes as a package or is constructed on site from the various components. These typically require about 4% of building floor area.

### **Air Handling Unit Tonnage Output**

The following equation calculates the refrigeration output in tons of a coil.

$$\text{Tons} = 1.08 \cdot (T_1 - T_2) \cdot \text{CFM} / 12000$$

Where

- T1 = Entering air temperature of the coil in degrees F
- T2 = Leaving air temperature of the coil in degrees F
- CFM = Volume of air passing through the coil

### TYPES OF AHU

AHU's are available in a wide range of sizes. They come in a variety of forms suitable for different applications.

**Central system:** Consists of more than one AHU served by the same source of heat and/or cooling. These are usually custom built for particular application.

**Unitary equipment:** Consists of a factory-assembled AHU and cooling compressor contained within a compact enclosure. It is distinguished from a room air conditioner by its capability of being connected to a ductwork. These are further categorized as package terminal air conditioners, rooftop systems and split systems.

**Packaged Unit:** A *packaged unit* (PU) is a self-contained air conditioner that does not receive hot or cold water from a central plant. It conditions the air and provides it with motive force and is equipped with its own heating and cooling sources. The packaged unit is the primary equipment in a packaged air-conditioning system and is always equipped with a DX coil for cooling, unlike an AHU. R-22, R-134a, and others are used as refrigerants in packaged units. The portion that handles air in a packaged unit is called an *air handler* to distinguish it from an AHU. Like an AHU, an indoor air handler has an indoor fan, a DX coil (indoor coil), filters, dampers, and controls. Packaged units can be classified according to their place of installation: rooftop and split packaged units. Direct expansion includes single packaged **rooftop systems** commonly seen in commercial buildings and **split systems** commonly seen in residential buildings.

**Roof Top Unit:** A roof-top packaged unit sometimes called a penthouse unit is installed on the roof and is completely weatherproof. It is designed to be supported on a roof of the conditioned space with supply and return air ducts generally located on the bottom of the unit. From the types of heating/cooling sources provided, rooftop units can be subdivided into:

- Gas/electric rooftop packaged unit, in which heating is provided by gas furnace and cooling by electric power-driven compressors.
- Electric/electric rooftop packaged unit, in which electric heating and electric power-driven compressors provide heating and cooling.
- Rooftop packaged heat pump, in which both heating and cooling are provided by the same refrigeration system using a four-way reversing valve (heat pump) in which the refrigeration flow changes when cooling mode is changed to heating mode and vice versa. Auxiliary electric heating is provided if necessary.

Rooftop packaged units are single packaged units. Their cooling capacity may vary from 3 to 220 tons with a corresponding volume flow rate of 1200 to 80,000 CFM. Rooftop packaged units are the most widely used packaged units.

**Indoor Packaged Units:** An *indoor packaged unit* is also a single packaged and factory-fabricated unit. It is usually installed in a fan room or a machinery room. A small or medium-sized indoor packaged unit could be floor mounted directly inside the conditioned space with or without ductwork. The cooling capacity of an indoor packaged unit may vary from 3 to 100 tons and volume flow rate from 1200 to 40,000 CFM. Indoor packaged unit usually has its compressors located indoors and condensers outdoors.

**Split Packaged Units:** A *split packaged unit* consists of two separate pieces of equipment: an indoor air handler and an outdoor condensing unit. The indoor air handler is often installed in the fan room. Small air handlers can be ceiling hung. The condensing unit is usually located outdoors, on a rooftop or podium or on the ground.

A split packaged unit has its compressors and condenser in its outdoor condensing unit, whereas an indoor packaged unit usually has its compressors indoors. The cooling capacity of split packaged units varies from 3 to 75 tons and the volume flow rate from 1200 to 30,000 CFM.

**Make-Up Air and Recirculating Units:** A make-up AHU, also called a primary-air unit, is used to condition outdoor air entirely. It is a once through unit. There is no return air and mixing box. Recirculating units can have 100% outdoor air intake or mixing of outdoor air and recirculating air.

**Fan coil unit (FCU):** A fan-coil unit is a small-scale air handling unit with circulation fan, cooling and/or heating coil, filter, and appropriate controls. It is essentially a terminal device because it serves only one room or a small group of rooms.

Fan-coil control is typically achieved through control of water flow through the coil using a control signal from the zone thermostat. Further control is sometimes provided by a multi-speed fan option. Occupants can usually adjust supply air louvers to provide some control over air distribution patterns. The most critical performance issue facing an all-water fan-coil system is ventilation air. Fan-coil units installed on an exterior wall can be equipped with an outdoor air connection so that ventilation may be provided. Fan coils installed in interior zones can not easily provide such outdoor air ventilation. An air-water fan-coil system can overcome this constraint. In a fan-coil system, a major system component (the fan-coil unit itself) is installed in or adjacent to occupied spaces, requiring that filter changes and maintenance of fans and coils occur in these spaces. Fan noise may be a concern in some critical occupancies. It is most commonly used in hotels, condominiums, and apartments.

**Induction Units:** Externally, an induction unit looks very much like a fan-coil unit; the difference is internal. An induction unit employs high velocity air flow from a central air handling unit to induce a flow of room air into and through the cabinet. This induction effect replaces the motive force provided by the fan in a fan coil unit. The mixture of central air (termed primary air) and room air (secondary air) passes through a coil in the unit and is conditioned to suit the needs of the zone. Filtration of the secondary room air at the induction cabinet is common.

### **Air handling Units Configurations**

Air handling units can be either blow-through or draw through.

**Blow-through units** add fan heat (usually equivalent to 2-3°F) before the cooling coil. This maximizes the temperature rise between the cooling air and the space design



temperature or minimizes the amount of supply air needed to condition a space. Since the air is often saturated and moisture problems may occur, a blow-through design should not be used with final filters downstream of the coils.

**Draw-through units** add fan heat after the cooling coil and typically need 10% more supply air than blow-through units to achieve the same zone cooling effect. This added supply air increases the duct size requirement and fan operating costs. Moisture is less of an issue with draw through units because the fan heat helps to reduce the saturation of the supply air.

### Details of AHU components

The air handling system consists of various components such as fans, ducts, & dampers. Each set of components performs a task critical to the proper operation of the system as well as occupant comfort.

### FANS

Required for moving air. The fan and motor selection is based on the supply air fan capacity and static pressure. There are two main types of fans, centrifugal and axial.

- Centrifugal fans discharge air perpendicular to the axis of the impeller rotation. As a general rule, centrifugal fans are preferred for higher pressure ducted systems.
- An axial fan discharges air parallel to the axis of the impeller rotation. As a general rule, axial fans are preferred for high volume, low pressure, and non-ducted systems.

Centrifugal	Axial	Special Designs
Forward Curved (FC)	Propeller	Roof ventilators
Radial Fans (RF)	Tubeaxial	Inline Centrifugal
Backward Inclined (BI)	Vaneaxial	Plug / Plenum fans

Backward Curved (BC)		Blowers
Aerofoil Bladed (AF)		

The centrifugal fan with a backward-curved impeller is the predominant fan used in “built-up” type air conditioning units, while the forward-curved impeller centrifugal fan is used in “package” type air handling units. In most cases, vane-axial and **backward-curved centrifugal fans** are the most efficient AHU fan choice. Fans are tested in accordance with requirements of AMCA (Air Moving and Conditioning Association) Standard 210.

**Fan Laws:**

- Law #1: CFM varies directly with RPM
- Law #2: Static pressure varies with the square of the RPM
- Law #3: Horsepower varies with the cube of the RPM

Note that fan power is proportional to flow cubed; cutting fan speed by about 50% will reduce fan energy to 1/8th. Therefore, for air conditioning applications, “Variable Speed Drives” (VSD) are the most energy efficient option.

**Centrifugal Fan Pressure Classes:**

- Class 1: Fans up to 4.5" pressure
- Class 2: Fans from 4.5” to 7"-8" pressure, heavier gauges & larger shafts than Class 1
- Class 3: Fans above 7"-8" pressure, heavier gauges & larger shafts than Class 2

**Fan Motors:** Fan motors shall be sized so they do not run at overload anywhere on their operating curve. Fan operating characteristics must be checked for the entire range of flow conditions, particularly for forward curved fans. Fan drives shall be selected for a

1.5 service factor and fan shafts should be selected to operate below the first critical speed.

A fan operating at a higher elevation or temperature will move the same volume of air as it will at standard conditions; however it will generate less total pressure and will require less horsepower. Note that the volume of air is not affected by variations in air density. In other words, if a fan will move 3,000 CFM at 70°F it will also move 3,000CFM at 250°F. Since 250°F air weighs only 34% of 70°F air, the fan will require less BHP but also create less pressure than specified. Therefore, when selecting a fan to operate at a non-standard density using standard air density tables and curves, corrections must be made to the parameters affected by air density. These parameters are static pressure and brake horsepower.

## COILS

Coils are used in air conditioning systems either to heat or cool the air. Coils consist of tubes and external fins arranged in rows along the air flow to increase the contact surface area. Tubes are usually made of copper; in steam coils they are sometimes made of steel or even stainless steel. Copper tubes are staggered in 2, 3, 4, 6, 8, or up to 10 rows. *Fins* are extended surfaces often called *secondary surfaces* to distinguish them from the *primary surfaces*, which are the outer surfaces of the tubes. Fins are often made from aluminum, with a thickness  $t = 0.005$  to  $0.008$  in., typically  $0.006$  in. Copper, steel, or sometimes stainless steel fins are also used. A higher number of fins increase the air pressure drop (fan horsepower) whereas higher number of rows increase water pressure drop (pump horsepower). Limit face -velocity to 450 - 500 feet per minute (fpm) for VAV systems and 400 - 500 fpm for constant air volume systems.

- **Water cooling coil:** In a water cooling coil, chilled water at a temperature of 40 to 50°F, enters the coil to cool and dehumidify the air. When the air temperature required is less than 50°F, a brine solution at a temperature of 34 to 40°F is used as the cooling medium because of its exposure to subfreezing temperatures in the refrigeration machine. The temperature of chilled water, brine, or glycol-water is usually raised 12 to 24°F before it leaves the water cooling coil. The water tubes are usually copper tubes of 1/2 to 5/8 in. diameter with a tube wall thickness of 0.01 to 0.02 in. They are spaced at a center-to-center distance of

0.75 to 1.25 in. longitudinally and 1 to 1.5 in. transversely. These tubes may be staggered in 2, 3, 4, 6, 8, or 10 rows. Chilled water coils are often operated at a pressure of 175 to 300 psig.

- **DX Coil** - In a *direct expansion coil*, the refrigerant, R-22, R-134a, or others, is evaporated and expanded directly inside the tubes to cool and dehumidify the air. Refrigerant is fed to a distributor and is then evenly distributed to various copper tube circuits typically 0.375 in. in diameter. Fin density is usually 12 to 18 fins/in. and a four-row DX coil is often used. On the inner surface of the copper tubes, microfins, typically at 60 fins/in. and a height of 0.008 in. are widely used to enhance the boiling heat transfer.

Direct expansion-type coils are used on small systems when a chilled-water system is not economical. Chilled water is used on all other systems when the air temperature required is above 50°F.

- **Hot water heating coils:** Heating coils are heat exchangers between a heating medium and the air stream. Heating coils will use either steam or hot water as a heating medium. The construction of a water heating coil is similar to that of a water cooling coil except that in water heating coils hot water is supplied instead of chilled water and there are usually fewer rows, only 2, 3, and 4 rows, than in water cooling coils. Hot water pressure in water heating coils is often rated at 175 to 300 psig at a temperature up to 250°F.
- **Steam heating coils:** In a steam heating coil, latent heat of condensation is released when steam is condensed into liquid to heat the air flowing over the coil. Steam enters at one end of the coil, and the condensate comes out from the opposite end. For more even distribution, a baffle plate is often installed after the steam inlet. Steam heating coils are usually made of copper, steel, or sometimes stainless steel. For a steam coil, the coil core inside the casing should expand or contract freely. The coil core is also pitched toward the outlet to facilitate condensate drainage. Steam heating coils are generally rated at 100 to 200 psig at 400°F.

## FILTERS

Used for removing airborne particle from the air that could cause discomfort to your building's occupants or possibly damage sensitive equipment. Filters and other air cleaning devices are available in four general types: (1) typical commercial filters that remove visible dirt, dust, lint, and soot, (2) electrostatic filters that remove microscopic particles such as smoke and haze, (3) activated charcoal that destroys odor and (4) ultraviolet lamps that kill bacteria.

Filters are normally installed in air handling units/package units, ahead of the coils, and in a position to filter both recirculation and outside air. Pre-filters are installed on the fresh air path.

Operating performance of air filters is indicated by their:

- Efficiency or effectiveness of dust removal
- Dust holding capacity, which is the amount of dust held in the air filter, in grains/ft<sup>2</sup>
- Initial pressure drop when the filter is clean and final pressure drop when the filter's dust holding is maximum, both in inch water gauge.
- Service life, which is the operating period between initial and final pressure drop.

Three test methods are used for the testing of low-, medium-, and high-efficiency air filters.

The **weight arrestance test** is used for low-efficiency air filters to assess their ability to remove coarse dusts. By measuring the weight of dust fed and the weight gain due to the dust collected on the membrane of the sampler after the tested filter, the arrestance can be calculated.

The **atmospheric dust spot efficiency test** is used for medium-efficiency air filters to assess their ability to remove atmospheric dusts. *Atmospheric dusts* are dusts contained in the outdoor air, the outdoor atmosphere. Approximately 99% of atmospheric dusts are dust particles <0.3 mm that make up 10% of the total weight; 0.1% of atmospheric dusts is particles >1 mm that make up 70% of the total weight.

The **DOP penetration and efficiency test** or simply *DOP test* is used to assess high-efficiency filters removing dusts particles of 0.18 mm.

Pressure drop is proportional to velocity squared. Doubling the surface area of a filter (example by increasing duct diameter, or pleating the filter) allows a 50% reduction in velocity while maintaining equivalent flow and thereby reduces pressure drop to 1/4th.

### Filter Comparison

Filter Type	ASHRAE Arrestance Efficiency	ASHRAE Atmospheric Dust Spot Efficiency	Initial Pressure Drop (IN.WG)	Final Pressure Drop (IN.WG)
Permanent	60-80%	8-12%	0.07	.5
Fiberglass Pad	70-85%	15-20%	0.17	.5
Polyester Pad	82-90%	15-20%	0.20	.5
2" Throw Away	70-85%	15-20%	0.17	.5
2" Pleated Media	88-92%	25-30%	0.25	.5-.8
60% Cartridge	97%	60-65%	0.3	1.0
80% Cartridge	98%	80-85%	0.4	1.0
90% Cartridge	99%	90-95%	0.5	1.0
HEPA	100%	99.97%	1.0	2.0

The filter media is rated in accordance with ASHRAE Standard 52: For comfort applications, pre-filters shall be 30 percent to 35 percent efficient and final filters shall be 85 percent efficiency capable of filtering down to 3.0 microns.

Another common metric for filter performance is the minimum efficiency reporting value (MERV), a rating derived from a test method developed by ASHRAE. The MERV rating indicates a filter's ability to capture particles between 0.3 and 10.0 microns in diameter. A higher MERV value translates to better filtration, so a MERV-14 filter works better than a MERV-8 filter.

For clean room applications, high efficiency particulate air (HEPA) filters are specified. HEPA filters are replaceable extended-media dry-type having a minimum particle collective efficiency of 99.97 to 99.997% for a 0.3 micron particle, and a maximum clean filter pressure drop of 2.54 cm (1") water gauge, when tested at rated air flow capacity.

Activated-Carbon filters are recommended in the areas subjected to volatile organic compounds (VOC's). Capacity: 8.8 lb (4.0 kg) of activated carbon per 2000 CFM of airflow.

**Mixing Boxes:** Air-handling units are provided with mixing boxes where relief air is discharged from the air handling unit. Mixing boxes may also be used on the return side of the unit in lieu of a plenum box. Air flow control dampers shall be mounted within the mixing box or on the ductwork connecting to the mixing box.

**Drain pan enclosure:** Collects condensate from a cooling coil. Constructed of heavy galvanized iron or stainless steel; insulated to prevent the enclosure from sweating.

**Humidifiers:** Humidifiers are devices that add moisture to the airstream, thereby raising the relative humidity of the conditioned space. In most comfort air conditioning systems and in many industrial air conditioning systems, humidifying devices are commonly sparging steam or atomizing water directly into the airstream.

**Control System** - A control system monitors and control temperature, humidity, duct pressure, airflow, dampers, sound alarms, and provide data to remote locations. These systems are operated either pneumatically or electronically, or a combination of both. For the most economical operation of the air conditioning system, controls must be maintained.

### **Selection of Air handling & Package Units**

The size of an AHU is usually selected so that the face velocity of its coil is less than 600 fpm in order to prevent entrained condensate droplets. The cooling and heating capacities of an AHU can be varied by using coils of different numbers of rows and fin densities. *High row deep cooling coils are generally used for high latent load applications where moisture removal is primary concern.*

The size of a PU is determined by its cooling capacity. Normally, the volume flow rate per ton of cooling capacity in PUs is 350 to 400 cfm. In most packaged units whose supply fans have belt drives, the fan speed can be selected so that the volume flow rate is varied and external pressure is met.

ASHRAE Standard 90.1-1989 specifies that the selected equipment capacity may exceed the design load only when it is the smallest size needed to meet the load. Selected equipment in a size larger always means a waste of energy and investment.

To improve the indoor air quality, save energy, and prevent smudging and discoloring building interiors, a medium-efficiency filter of dust spot efficiency 50% and an air economizer are preferable for large AHUs and PUs.

---



## **SECTION – 4            AIR DISTRIBUTION DUCTWORK**

### **General**

Air conditioning and heating systems require some form of duct work to channel or direct the air to places where the conditioned air is needed. The power that causes the air to move through the supply ducts is supplied by the fan in the AHU unit and the motor that drives the fan.

Several issues must be considered in an effective design. A primary issue is the tradeoff between the initial cost of the duct system and the energy cost of the air distribution system; larger ducts require a larger initial investment, but result in lower fan energy costs over the life of the system. Other issues include space available, noise level, capacity for expansion, appearance etc. It is important that the air conditioning ductwork system be designed for the air conditioning load in accordance with the general rules outlined in the latest ASHRAE Guide and Data Books, SMACNA Manuals and Design Guide Section of the Associated Air Balance Council Manual.

### **Ductwork categories**

Supply duct systems are designed and constructed in many different ways. They may be categorized as follows:

#### **Round vs. rectangular**

They may be either round or rectangular. Both types have advantages and disadvantages, and both find applications where one is definitely superior to the other. A round duct, however, is more efficient than a rectangular duct in performing the same task; round ductwork provides maximum air-carrying capacity with minimum pressure loss.

A round duct has a smaller cross-sectional area and has less duct wall exposed to moving air. An 18 inch diameter duct, for example, has the same air-carrying capacity as a 26" x 11" rectangular duct. The round duct has a cross-sectional area 254.5 sq-in and a perimeter of 4.7 ft, while the rectangular duct has 286 sq-in area and a perimeter of 6.2 ft. The rectangular duct thus has 32% more metal in it and would cost proportionately

more. Also the insulation, supports and labor shall be higher for rectangular ducts of similar capacity.

One big disadvantage of round duct is; they require more clear height for installation. If the net clear height of a furred space above suspended ceiling is, for example, 14 inches, an 18 in diameter duct cannot be installed therein; however, its equivalent 26" x 11" rectangular duct will fit the space easily.

When rectangular ducts must be used due to space limitations, keep the aspect ratio\* close to 1:1. Avoid using duct with an aspect ratio greater than 3 to 1, if possible.

**Aspect ratio:** The aspect ratio is the ratio of the long side to the short side of a duct. This ratio is an important factor to be considered in the initial design. Increasing the aspect ratio increases both the installed cost and the operating cost of the system. A rectangular duct with an aspect ratio closer to ONE has lower frictional resistance and will use lowest sheet metal.

Example:

Say the main trunk of the duct requires cross-sectional area of 4 sq-ft and is 100 ft long. The duct can be fabricated as 2' x 2' or 1' x 4' dimensions.

In first case 2' x 2', the perimeter = 8 ft and total sheet metal required is  $8 \times 100 = 800$  sq-ft

In second case 1' x 4', the perimeter = 10 ft and total sheet metal required is  $10 \times 100 = 1000$  sq-ft

As the aspect ratio increases from 1: 1 to 1: 4, the surface area and insulation requirements increase 25% percent. Other benefits of low aspect ration include low friction drop, low weight of metal, lower insulation and installation costs.

### **Velocity Classification**

A duct system may also be categorized by air velocities. Low-velocity systems are designed with duct velocities of 1500 fpm or less for comfort air conditioning systems and up to 2500 fpm for industrial air conditioning systems. Low-velocity design will lead to larger duct sizes, but it may be worth since, doubling of duct diameter will reduce

friction loss by a factor of 32 times and will be less noisy. The low-velocity systems occupy more space and have higher first costs; facility owners are often reluctant to provide the space for more expensive ductwork, but significant energy savings can be realized even when the ductwork is only increased by one standard size.

High-velocity systems employ duct velocities up to 6,000 fpm. Higher duct velocities result in higher duct system resistance (pressure drop) which results in increased fan horsepower. High velocity ducts are smaller for a given air quantity and require less space for their installation, but they have a higher initial cost and even greater operating cost.

**Velocity in feet per minute (FPM) = Airflow in cubic feet per minute (CFM) / Sq-ft of duct cross-section**

### Pressure Classification

Duct systems are also divided into three pressure classifications, matching the way supply fans are classified. The pressures are total pressure and include all losses through the air source unit, the supply ductwork, and the air terminals, return air grilles, and return ductwork. The pressure classifications are:

Low Pressure:	Up to 4.0 in-wg -	Class I Fan
Medium Pressure:	From 4.0 to 6.0 in-wg -	Class II Fan
High Pressure:	From 6.0 to 12 in-wg -	Class III Fan

As a good engineering practice -

- Primary air ductwork (fan connections, risers, main distribution ducts) shall be medium pressure classification.

- Secondary air ductwork (run-outs/branches from main to terminal boxes and distribution devices) shall be low pressure classification.

### **Duct frictional resistance**

Any type of duct system offers frictional resistance to the movement of supply air. The frictional resistance of a supply duct varies in proportion to the square of the ratio of the velocity at two different velocities, and the fan power varies as the cube of this ratio. If a supply duct, for example, is carrying 5000 cfm of air at 1000 fpm, and a second supply duct is carrying the same quantity of air at 2000 fpm, the frictional resistance of the second duct per foot of duct length will be four times higher than that of the first duct:  $(2000/1000)^2$ ; and the power required to overcome this frictional resistance will be eight times as much:  $(2000/1000)^3$ .

The AHU fan must develop a pressure equivalent to the frictional resistance of the ductwork in order to supply air in the spaces to be conditioned. This pressure is measured in terms of inches of water. The total pressure in the duct system is the sum of static and velocity pressures. Static pressure is the outward push of air against duct surfaces as a result of the compressive force applied by the fan; velocity pressure is the directional thrust of supply air due to its velocity. A decrease in duct size increases velocity pressure and decreases static pressure; an increase in duct size decreases velocity pressure, increases static pressure.

**Duct equivalent length:** The fittings (elbows, tees, branch connections, etc.) and accessories (dampers, extractors, etc.) in the ductwork offer additional frictional resistance. An additional length has to be added to the actual measured length of the ductwork to take care of the resistance offered by these items to supply air. This additional length is called equivalent length, and the sum of actual measured length and equivalent length is known as total equivalent length (TEL).

$$\text{TEL} = L + (C \cdot L)$$

Where

- L = actual measured length

- C = a coefficient of duct system complexity (0.4 for simple duct systems, 1 for very complex duct systems).

## DUCT MATERIALS

Supply ducts may be further categorized according to the materials of which the ducts are made.

### Metallic Ducts

- **Galvanized Steel** - Widely used as a duct material for most air handling systems; not recommended for corrosive product handling or temperatures above 400°F. Advantages include high strength, rigidity, durability, rust resistance, availability, non-porosity, workability, and weldability. Specifications - Galvanized steel sheets meeting ASTM A90, A525, and A527, Lock Forming Quality
- **Carbon Steel (Black Iron)** - Applications include flues, stacks, hoods, other high temperature duct systems, and ducts requiring paint or special coating. Advantages include high strength, rigidity, durability, availability, weldability, and non-porosity. Some limiting characteristics are corrosion resistance and weight. Specifications - Carbon steel meeting ASTM A569 for stacks and breechings 24" and larger; Galvanized sheet steel meeting ASTM A527 with ANSI/ASTM A525 G90 zinc coating for stacks and breechings less than 24 inches.
- **Aluminum** - Aluminum ducts are light in weight, but basic cost per pound is higher than galvanized steel. Aluminum ducting is most commonly used for clean room applications and is also preferred systems for moisture laden air, special exhaust systems and ornamental duct systems. Some advantages include weight and resistance to moisture corrosion. Limiting characteristics include low strength, material cost, weldability, and thermal expansion. Specifications - Aluminum base alloy sheets meeting ASTM B209, Lock Forming Quality.
- **Stainless Steel** - Used in duct systems for kitchen exhaust, moisture laden air, and fume exhaust. Advantages include high resistance to corrosion from moisture and most chemicals and the ability to take a high polish. Limiting

characteristics include labor and material costs, workability, and availability. Specifications - Type 304, 304L, 316, or 316L stainless steel sheets meeting ASTM A167

- 304 and 316: Non-welded applications.
- 304L and 316L: Welded applications.
- **Copper** - Copper applications include duct systems exposed to outside elements and moisture laden air, certain chemical exhaust, and ornamental ductwork. Advantages are durability and corrosion resistance and that it accepts solder readily and is nonmagnetic. Limiting characteristics are cost, ductility, electrolysis, thermal expansion, and stains.

### **Nonmetallic ducts**

- **Glass fiber:** Made of glass wool insulating material in which the stranded fiber wool is compressed until a fairly rigid insulating board results. Available either in round or rectangular form. The ducts are faced on the outside with a noncombustible, aluminum foil vapor barrier jacketing material. The interior surface of the ducts is much rougher than galvanized steel, the frictional resistance is higher and static pressure loss is greater. More expensive than galvanized steel. They give very good sound attenuation.
- **Compressed paper:** Round tubes made of very strong, thick-walled paper. Available in a wide range of diameters. Used as a form in buried ducts around which concrete is poured. Frictional resistance is approximately equal to galvanized steel.
- **Plastic:** HVAC ducts are made of PVC to a limited extent. Limited to small sizes of approximately 12 in. diameter or less and of round configuration. Available as both flexible and rigid types. Flexible ones have corrugated walls which cause fairly lightweight plastic to hold its shape; extensively used to make connections from a main supply duct to supply air diffusers. Rigid ones are often used for direct burial ducts laid in the earth below concrete floor slab and connecting to registers in the floor. Capable of withstanding the attack of ground acids and other substances. Not required to be encased in concrete.

- **Vitrified Clay Tile and Concrete:** Almost always round. Suitable for direct underground burial. Very permanent and trouble free. Branch connections are very difficult. Conform to ASTM C76, Class IV.

### RECOMMENDED SHEET METAL THICKNESS

Rectangular Duct			Round Duct		
Greatest Dimension	Galvanized Steel (gauge)	Aluminum (gauge)	Diameter	Galvanized Steel (gauge)	Aluminum (gauge)
Up to 30 inch	24	22	Up to 8 inch	24	22
31 – 60 inches	22	20	9 – 24 inches	22	20
61 – 90 inches	20	18	25 – 48 inches	20	18
91 inches and above	18	16	49 – 72 inches	18	16

### Maximum ductwork hanger spacing

- Horizontal: 8 feet maximum
- Vertical: 16 feet and at each floor

### DUCT SIZING

#### Velocity Method

- Duct sizes are selected using the velocity of supply air.
- Formula to find out duct size [cross-sectional area (A) in square inches]:  $A = (\text{Volume of air in cfm} \times 144 \text{ in}^2/\text{ft}^2 \times \text{frictional allowance}) / \text{Velocity in fpm}$
- Frictional Allowance for round ducts = 1, Frictional Allowance for sq. ducts = 1.05 to 1.10, Frictional Allowance for rect. ducts = 1.25.

### **Constant Pressure Drop Method**

Used usually for a low velocity duct system, selecting a pressure drop (friction loss) of 0.1 inch per 100 feet of total equivalent duct length. Rectangular ducts can be interchanged with no substantial effect in performance with equivalent round size.

### **Static Regain Method**

- This method refers to increase or regain of static pressure in the ductwork when the air velocity decreases. Ducts are sized calculating air velocity for all sections where changes in air velocity takes place. Static regain calculations help to adjust duct size to obtain equal static pressure and correct air quantity at each outlet.

### **Ductwork Testing**

- -3"-WG and Lower: 1.5 x Pressure Rating
  - -2" to +2" WG: Generally not tested
  - +3" WG and Higher: 1.5 x Pressure Rating
-



## SECTION – 5 AIR DISTRIBUTION EQUIPMENT & ACCESSORIES

### General

The proper delivery of air for heating, cooling, or ventilation is a crucial part of the ducted air distribution system. When conditioned air is supplied to a space by ductwork, the duct has to terminate in an outlet device capable of introducing the air into the space in an air pattern that maintains the desired air temperature, humidity, and motion. The resulting conditions will be unsatisfactory if the air is not properly introduced.

### Throw

The horizontal distance that an air stream travels from an outlet before dropping is called its throw. The throw should be long enough to give the air stream time to mix sufficiently with room temperature so that its temperature and velocity reach comfortable levels before the air drops down into the occupied zone. Otherwise, uncomfortable drafts will result. If the air stream is warmer than the room air, it will tend not to drop at all.

### Types of outlets

Basically four types of supply outlets are available as standard manufactured products.

**Ceiling diffusers:** A diffuser is a device designed specifically to introduce supply air into a space, to provide good mixing of the supply air with the room air, to minimize drafts that would discomfort occupants, and to integrate with the ceiling system being used in the space in question. Diffusers are intended for ceiling installation and are available in many shapes, sizes, styles, finishes, and capacities. In many buildings, the only portions of an HVAC system seen by occupants on a day-by-day basis are the supply diffusers and return air registers or grilles. Although inherently simple devices, diffusers should be selected with care as they are the point where the effect of an HVAC system is implemented. In addition, they are normally the HVAC system component with the most aesthetic impact.

**Registers:** A register is a grille with damper directly behind the louvered face to regulate the volume of airflow. Apart from ceiling, registers are also used for wall and floor outlets.

**Perforated ceiling panels:** These are used when a large proportion of the ceiling may be used as an outlet. Perforated ceiling panels provide a well-distributed air supply straight down. These are widely used in clean room applications.

**Slotted diffusers:** Linear in shape, slotted diffusers are elongated outlets consisting of single or multiple slots usually installed in long continuous lengths. They are available in two basic flow patterns: perpendicular and parallel. The **perpendicular** type discharges air within 30° of perpendicular to the face of the diffuser; it creates long, narrow bands of conditioned air flowing into the room, and is best suited for perimeter heating applications. The **parallel** flow type discharges air parallel to the surface of diffuser and is suited for cooling applications.

### **Suitability of outlets**

No single type of outlets is suitable for both heating and cooling. The heating outlet location that most effectively provides comfort is near the floor at outside walls, especially below windows. It provides vertical stream of air that flows upward to blanket the cold surfaces and counteracts perimeter downdrafts of cold air. Adding heat at the area of highest heat loss prevents uneven air temperatures and an uneven radiant temperature distribution.

Proper cooling requires larger quantities of air than is generally needed for heating. This air must be carefully and evenly diffused. The best method is to deliver air through multiple outlets strategically located in the ceiling.

When a compromise is required for year-round operation of a single system, the optimum location is determined by the predominant application. Ideally, a ducted air system with ceiling registers/diffusers provides cooling and ventilation while a separate perimeter system, such as fin-tube radiation, is used for heating. When this is not possible, it is important that delivery device be carefully selected and located.

### **Return air**

Whenever air is supplied to a room, provisions must be made either to return the room air to the AHU or to exhaust it to the outside. This requires the installation of return air inlets. They should NOT be located close to the supply outlet or at the same height. This

will result in short circuiting which means that supply air will bypass portions of the space without conditioning it.

Return air inlets may be connected to a duct; they may lead to an undivided plenum above the ceiling from which air is drawn back to the AHU.

Return air inlets for cooling systems can be located in ceilings or high above on walls, provided they do not cause short circuiting. Return air inlets for heating systems must be located near the floor to discourage stratification of warm air near the ceiling, and across from the supply outlets to ensure heating throughout the room. Return inlets actually in the floor are undesirable because they readily collect dirt, which clogs the filter, and imposes an undue strain on the AHU.

### **Face velocity**

This is the velocity of air in fpm at some point in the distribution system based on overall area through which air is passing. e.g. face velocity of a register with a face area of 18 in. x 6 in., supplying a volume of 375 CFM of air, would be  $375/[(18 \times 6)/144] = 500$  fpm.

### **Dampers**

Dampers are devices used to control or restrict the airflow. They fall primarily into three categories: volume, backdraft, and fire/smoke dampers.

- **Volume Dampers** - Volume dampers are devices used to vary the volume of air that passes through an air outlet, inlet, duct, fan, air handling unit, cooling tower, or condenser unit. They may vary the volume from 0 to 100 percent of capacity. Some volume dampers can be opened and closed by hand, while others are opened and closed by a pneumatic or an electric operator. The largest use of manual controlled volume dampers in cooling systems is for air balancing.
- **Backdraft Dampers** - Backdraft dampers are devices used to limit the airflow within a duct to one direction and to stop airflow through a duct or opening when the fan is shut off. Backdraft dampers are opened automatically by the force of the airflow on the damper blades. They are closed automatically by a spring or weight counterbalance and by gravity. The counterbalances can be adjusted to allow the damper to pass the needed airflow. Backdraft dampers, because they

are free to open and close easily, may rattle and make noise. To eliminate this, felt or vinyl strips can be placed on the damper edges, which will also help minimize the air leakage.

- **Fire Dampers** - Fire dampers are devices used to close off individual sections of a building during a fire. Fire dampers in HVAC applications are generally interlocking blade or expanding curtain type. Fusible link fire dampers are dampers which close when a fusible link melts and permits the damper to close.
  - Type A: Return air and transfer air; frame and damper is located in the airstream
  - Type B: Low pressure supply air; frame and damper is totally recessed out of the airstream
  - Type C: High pressure supply air; frame and damper is totally recessed out of the airstream

The HVAC systems shall be designed to meet the requirements of the National Fire Protection Association codes, NFPA 45, 72E, 90A, 96, 99, and 101.

- **Smoke Dampers** - Smoke dampers are used for either smoke containment or for smoke control. The damper is basically the same as a volume damper, except the damper is classified and listed in accordance with Underwriters Laboratories, Inc. (UL) 555S, UL Standard for Safety Smoke Dampers Fourth Edition (1999). The damper is a two-position damper, i.e., the damper is either open or closed depending upon the control requirements. The dampers are opened and closed by a pneumatic or electric operator. The damper usually has low leakage characteristics.

### **Construction of Dampers**

Dampers are available in different constructions. They commonly consist of a series of moveable blades mounted in a frame. One of the most obvious attachments to a damper is a damper motor or actuator. These control the opening and closing of the dampers, in response to signals from the control system.

- **Single blade:** They are mostly manually operated and installed with a locking device, called a locking quadrant, by means of which they may be fixed in the desired position. May also be automatic and may either be center or edge pivoted.
- **Barometric:** Usually made with fine-tune adjustment features and equipped with adjustable counterweights. Often used in the smoke pipe of a furnace or boiler to stabilize draft conditions and permit close adjustment of fuel burners.
- **Multi-blade:** Used for control of large volumes of air moving at high or low velocities in large duct systems. They are of two types: parallel blade and opposed blade. In parallel blade type, all blades turn in same direction. In opposed blade type, alternate blade turns in opposite direction.
  - Opposed blade dampers should be used for balancing, mixing, and modulating control applications.
  - Parallel blade dampers should be used for 2 positioning applications (open/closed) such as air handling unit equipped with emergency smoke exhaust arrangement.

## Louvers

These are the elements which allow air to be drawn in from outside or discharged to outside, without allowing rain into the building. Louvers are shaped such that rain falling or being blown onto the louver is captured and channeled back to outside. Louvers may be incorporated into the side of a building, or they can take the form of free-standing penthouse arrangements.

- Normal **exhaust** louver sizing based on 700 FPM through free area of louver
- Normal **intake** louver sizing based on 500 FPM through free area of louver
- Free Area Range:
  - Metal: 40–70% of Gross Area
  - Wood: 20–25% of Gross Area

Problems encountered with louvers include louvers obstructed with leaves etc., supply and extract louvers which are located too close together allowing short-circuiting of stale air, or intake louvers located adjacent to areas in which vehicles run, allowing exhaust gases to be drawn into the building.

### **Aspiration ratio**

As supply air leaves a supply register, it has a certain volume of flow rate expressed in CFM; this is called **primary air**. As soon as this air leaves the outlet, it begins to attract air already existing in the room; this room air, called the **secondary air**, joins the primary air and is carried along with it. The moving air stream has now a much greater volume by the time it reaches the end of its throw. This total volume, divided by the primary air volume is called the aspiration ratio.

A high aspiration ratio is good, because it means that a greater quantity of air is kept in motion, with less chance of stagnation in parts of the room and with less chance of temperature stratification within the room.

---

## SECTION – 6                      SYSTEM DESIGN

The climate control system in a building has to maintain both the thermal climate and the air quality. Maintaining the thermal climate consists primarily of keeping the temperature/humidity of the indoor air within given limits. Maintaining the air quality consists of controlling the 'cleanliness' of the indoor air by supplying a sufficient quantity of outdoor air to ventilate the interior of the building. Maintenance of air quality also includes ensuring that given concentrations of particles and/or gases are not exceeded.

A system may be defined as an assembly of components with a particular structure and a defined function. The components addressed in the previous sections constitute the subsystems from which building-scale HVAC systems are assembled. There are literally hundreds of ways in which basic HVAC components may be assembled into systems. This section views some of the most commonly encountered system configurations. In general, HVAC systems can be divided up into three main types:

- All-air systems
- All-water systems
- Combined systems (with cooling supplied both by air and by water)

### ALL AIR SYSTEM

The design air flow rate in these systems, and thus the necessary sizes of ventilation ducts, is determined by the design cooling requirement. In other words, it is the thermal requirements, and not the air quality requirements, that determine the necessary air flow rate.

The cooling system must be able to deal with variations in the cooling requirement, whether over the day or over the year. The two basic types of all-air cooling systems are the **constant air volume (CAV) system** and the **variable air volume (VAV) system**, although there are also combinations of the two methods. The choice between CAV and VAV is dependent on the number of **zones**.

### Zone

A zone in HVAC terms is an area that will have similar thermal loads and that is controlled by a single thermostat. Building codes require zoning to save energy in commercial buildings. Zones are defined in the building to reduce the number of HVAC subsystems, and thus initial cost. Zones may not be confused with the individual spaces in a building; a building with several rooms may be controlled as a single zone.

### SINGLE ZONE SYSTEM

Single zone system is essentially served by a constant air flow “CAV” unit. Constant volume systems are common form of air-conditioning of single thermal zones and are often the system of choice due to simplicity, low cost and reliability. The air handler for CAV system consists of a supply fan that operates only at one speed, thus the delivered air flow rate is constant. When supplied with temperature reset, this type of system becomes a constant volume/variable temperature system (CVVT). The efficiency is increased somewhat but humidity problems can result.

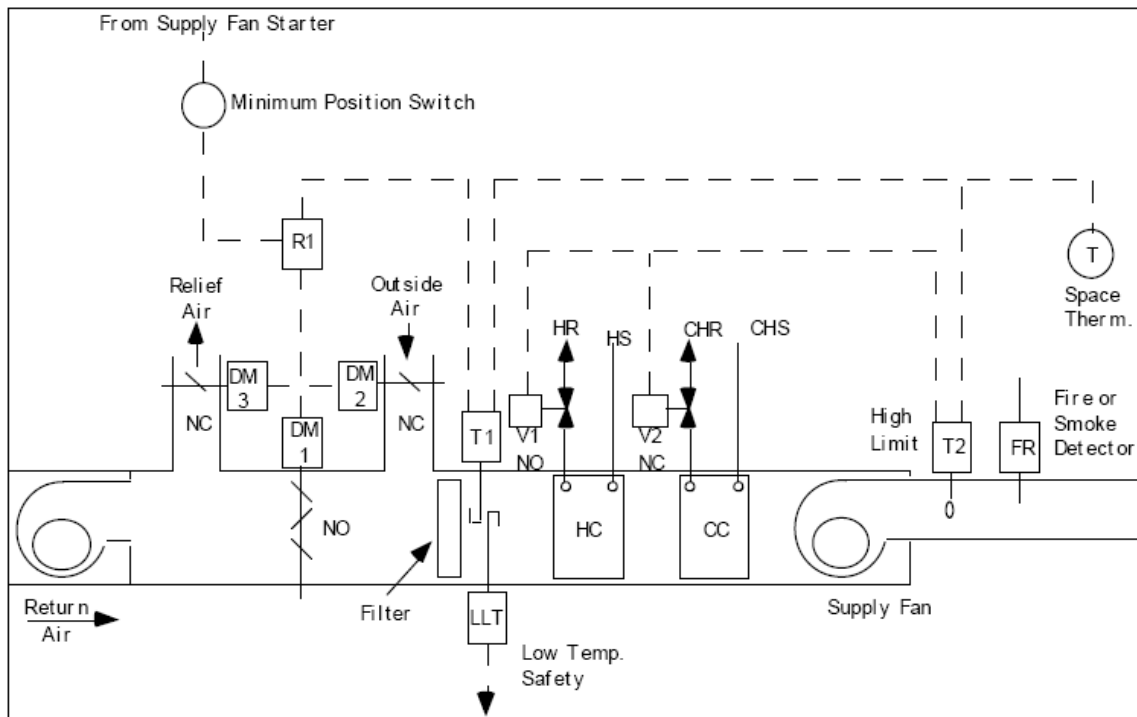

**Single Zone - All Direct Control from Space Thermostat**



[Legend: NC, NO – normally closed, normally open; DM – motorized damper, T – Temperature sensor; CHS, CHR – chilled water supply and return; HS, HR – hot water supply and return; R – relay; V – modulating valve... others marked on schematic]

In schematic above, a single AHU supplies conditioned air to a single zone. Only one coil operates at a time so that all of the air supplied is either hot or cold as called for. The quantity of supply is controlled either by modulating the air temperature or by turning the system on or off. These systems are used for relatively small areas (5,000 to 15,000 sq-ft) and small capacities.

Examples of Single Zone Units include constant volume air handling units, fan coil units and packaged units (PU). Multiple units can be installed on larger areas to serve various parts of a large building.

### **Energy Efficiency Requirements**

Constant volume, variable temperature systems use more fan work than variable air volume “VAV” systems because they are usually designed for a larger design supply air flow rate, and they cannot modulate the supply air flow rate during part load conditions.

ASHRAE STD 90.1-1999 require following considerations to the constant volume systems. The numbers in brackets refer to Std. 90.1-1999 sections.

1. Equipment must be scheduled off automatically during unoccupied hours [6.2.3.1].
2. Adjustment of economy cycle operation to ensure maximum gains are made from the use of fresh air for "free" cooling. Demand Controlled Ventilation is required for systems with at least 3,000 CFM of outdoor air and occupant density greater than 100 people per 1,000 ft<sup>2</sup> [6.2.3.9].
3. Air- or water-side economizers are required. There are several exceptions to this rule, particularly when dealing with heat recovery [6.3.1].
4. Where humidification is required to maintain humidity above 35°F dewpoint, water-side economizers must be used when economizers are required. Introducing large amounts of cool, dry air while meeting the sensible cooling load adds significantly to the humidifier load. Process loads, including hospitals, are exempt [6.3.2.4].
5. Energy recovery is required for systems with at least 5,000 CFM supply air and a minimum of 70% outdoor air. This is specifically aimed at schools and labs [6.3.6.1].

- 6. For systems under 20,000 CFM, constant volume fans are limited to 1.2 hp/1,000 CFM. For systems over 20,000 CFM, fans are limited to 1.1 hp/1,000 CFM [6.3.3.1].

**MULTIZONE SYSTEMS**

A multi-zone system supplies constant volume of air to each space it serves. Heating and cooling is accomplished by varying the supply air temperature to each zone separately.

**Multi-zone (Single duct with reheat):** When a constant volume unit serves multiple zones, not all zones will need full cooling at the same time due to unequal loading. For example the perimeter areas with different solar exposures will see different loads through out the day, while the interior zones will see a fairly constant load. Because the system cannot vary the supply air volume to each zone, some zones will have to supply warmer air to maintain the space setpoint. This is achieved by terminal reheat. The terminal reheat units are controlled by a thermostat in the occupied space and apply heating to adjust the air supply temperature to that required to maintain comfortable conditions in the room. This arrangement provides for simple control but is very inefficient, as the supply air is often both cooled and heated, resulting in energy waste.

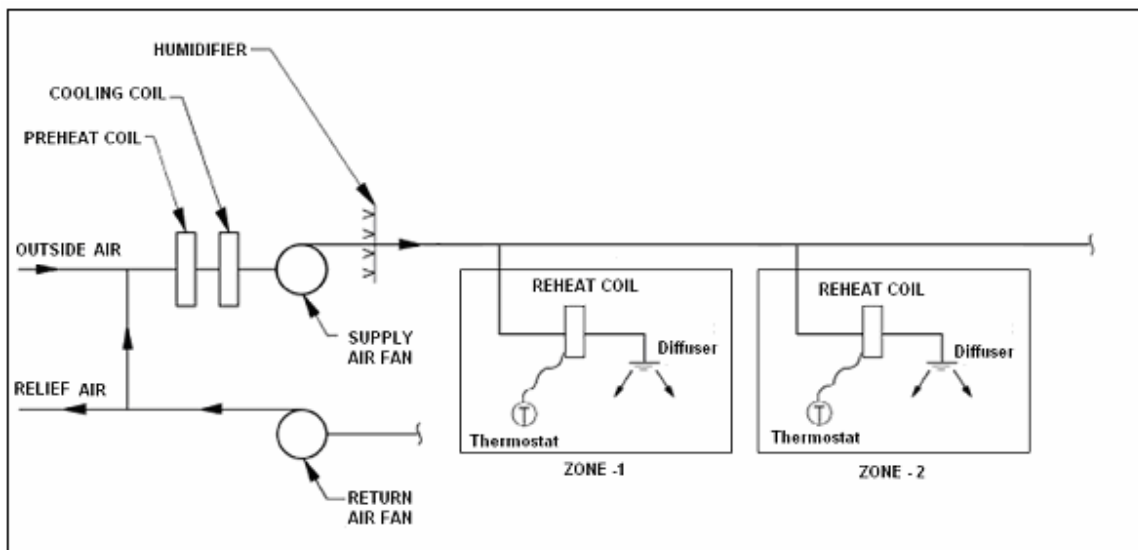

**Multi Zone – Served by CAV with Reheat Terminals**

**Multi-zone (Double duct with mixing damper in one duct):** Contains a heating deck to meet the requirements of the coldest zone and a cooling deck to meet the demands of

the hottest zone. The arrangement runs two independent duct systems, one warm, one cool, which circulate air in parallel sets of ducts through all sections of the building. Mixing in correct proportion for each zone is done by motorized damper in the terminal duct to satisfy the demands of all zones.

Depending on the temperature needs of the area, the mixture of hot and cold air is adjusted until the desired temperature is reached. Unfortunately, with this arrangement, you must pay to cool, heat and circulate this volume of air, which is typically much larger than the actual volume required by your building.

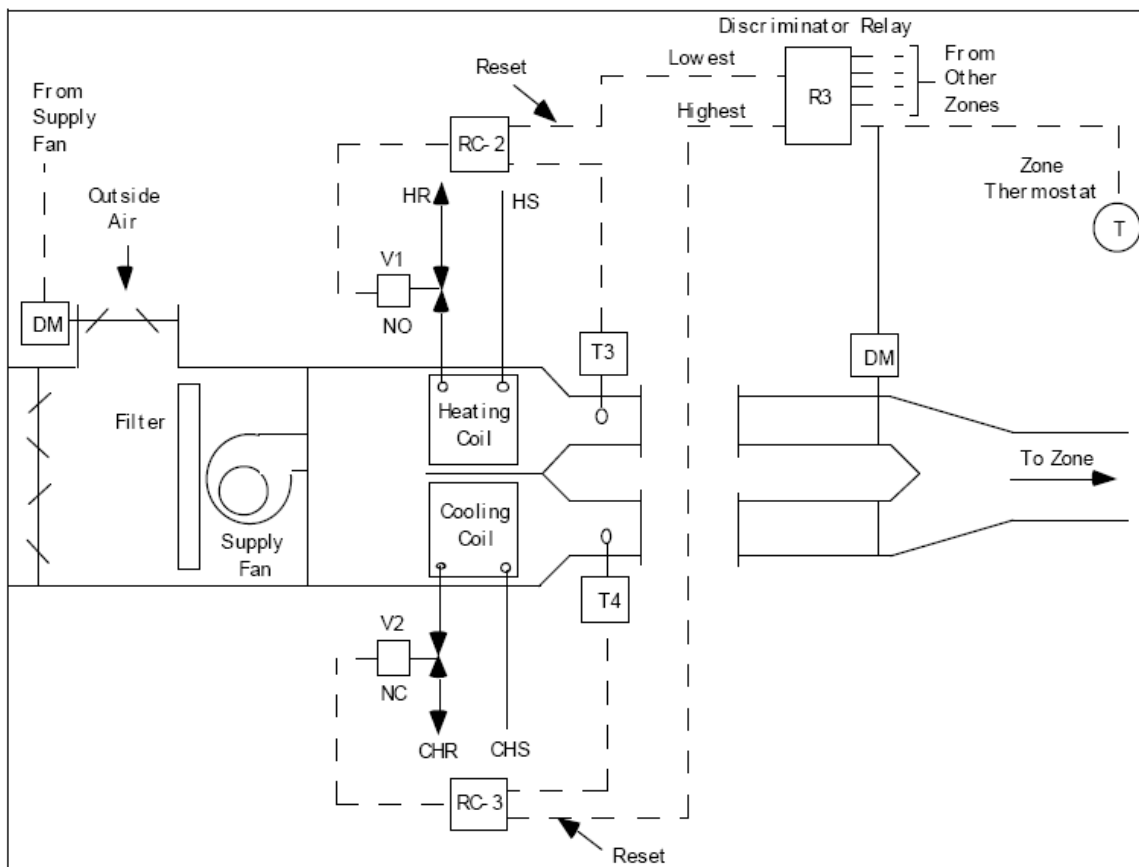

**Multi-zone with mixing damper at one duct**

**Multi-zone (Double duct with mixing box):** A separate hot and cold duct are paralleled throughout the supply network and mixed at zone terminal mix boxes. Takes up more space than single-duct system. Provides excellent temperature control, but wastes

energy: uses energy for heating and cooling and then mixing the two air streams together.

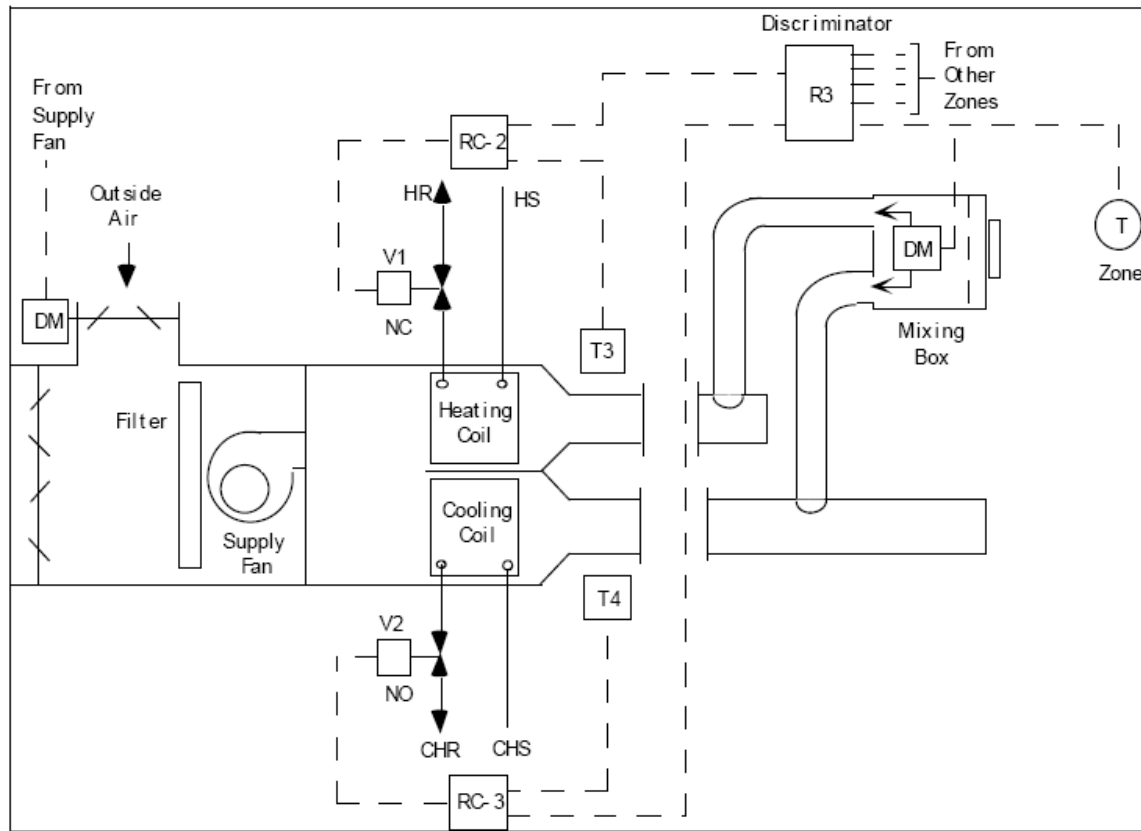

**Dual Duct Air Handling System**

### **Variable Air Volume (VAV) Systems**

Variable air volume systems usually referred to as “VAV” supply varying quantities of conditioned (heated or cooled) air to different parts of a building according to the heating and cooling needs of those specific areas. Air flow can be modulated all the way down to zero flow when there is no conditioning required, although a minimum is usually set above zero to satisfy fresh air requirements. The system cools or heats the air to accommodate the zone with most extreme requirements and transports the air through a single duct to all zones. Volume of air to the space is controlled by a VAV valve. VAV systems can substantially reduce fan and cooling energy. It is primarily a cooling system.

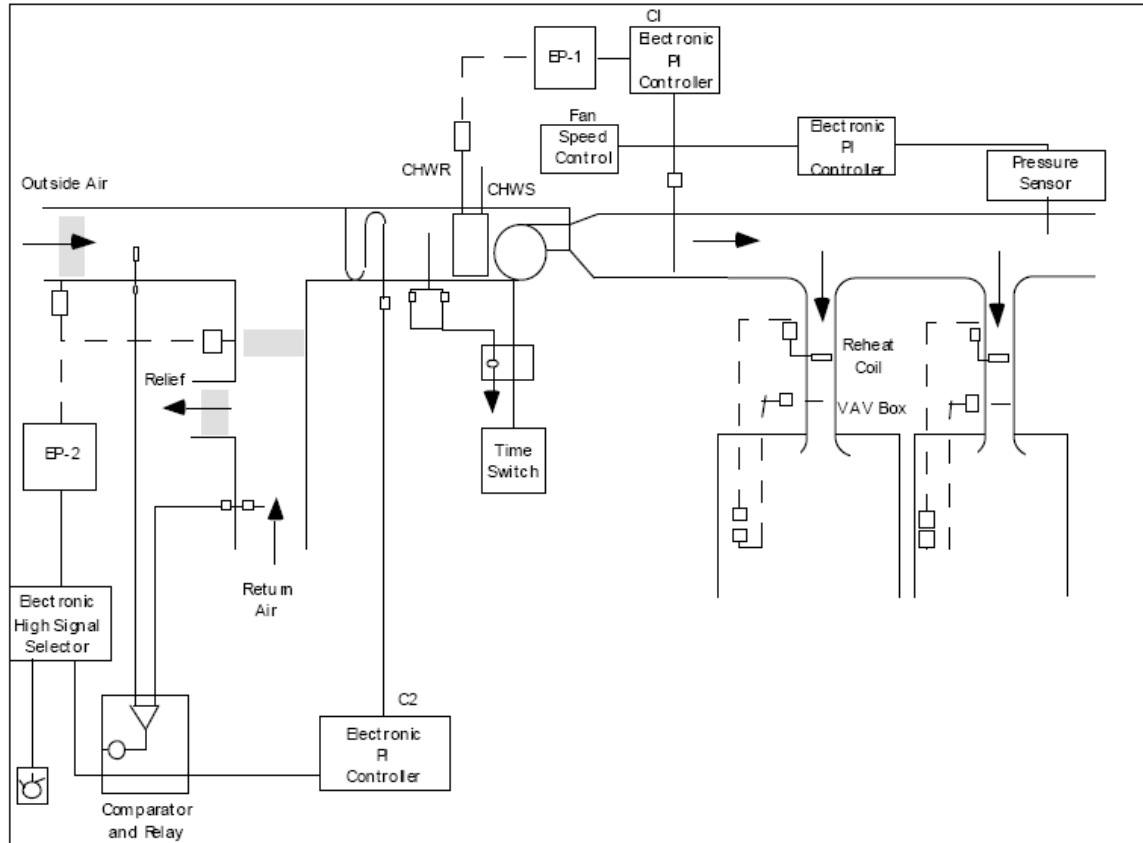

### VAV Control System

#### Type of Variable air volume terminal units

There are generally five different types of units that are used: pressure-independent volume units; pressure-dependent, airflow-limiting, maximum volume units; pressure-dependent units; bypass (dumping) units; and supply outlet throttling units. One other type of unit that is used is the fan-powered variable air volume terminal unit.

- **Pressure – Independent Units** - Pressure-independent volume units regulate the flow rate in response to its respective thermostat's call for heating or cooling. The thermostat controls airflow to the space by varying the position of a simple damper or volume regulating device located in the unit. The required flow rate is maintained, regardless of the fluctuation of the system pressure being supplied by the air handling unit supply fan. These units can be field- or factory-adjusted for maximum and minimum airflow settings.
- **Pressure Dependent-Airflow Limiting Maximum Volume Units** - A pressure-dependent, airflow-limiting, maximum volume unit regulates maximum volume,

but the flow rate will oscillate when system pressure varies. These units are less expensive than pressure-independent units. These units can be used where pressure independence is required only at maximum airflow, where system pressure variations are relatively small, and where some degree of fluctuation or "hunting" is tolerable.

- **Pressure Dependent Units** - Pressure-dependent units do not regulate the flow rate, but position the volume regulating device in response to the thermostat. These units are the least expensive and should only be used where there is no need for maximum or minimum airflow control and the air handling unit system pressure is stable.
- **Bypass Dumping Units** - Generally, in small air handling systems, the cost of a variable air volume system is too high. However, by using bypass (dumping) units in certain zones or spaces, the constant volume system can have variable airflow control. The thermostat controls airflow to the space by varying the position of the volume regulating device. If less air is required to the space, the regulating device closes down and bypasses or diverts some of the air to the return ceiling plenum or return air duct.
- **Supply Outlet Throttling Units** - Supply outlet throttling units are usually linear diffusers. The area of the throat or the discharge opening varies in approximate proportion to the air volume to maintain throw patterns. The thermostats are usually located at the outlet of the diffuser for easy temperature adjustment. Since these units are pressure-dependent, constant pressure regulators are usually required in the duct system. Noise is a concern when using these units in occupied spaces.
- **Fan Powered Variable Air Volume Units** - Fan-powered variable air volume units are available in two types: parallel and series flow units. The units have the same components as pressure-dependent or pressure-independent volume units, and in addition, a fan and usually an electric or hot water heating coil. Fan-powered variable air volume units, both series and parallel, are often used for building perimeter heating, because they move more air through a room at low cooling loads and during the heating cycles compared to variable air volume reheat or perimeter radiation systems.

### ALL WATER SYSTEM

In an all-water system, conditioning effect is distributed from a central plant to conditioned spaces via heated or cooled water. Water is a very effective heat transfer medium and can convey a lot of heat per unit volume (compared to air). With hot water, heat can be carried over a large distances much more economically than hot air. Water piping is also less space consuming than duct work and pumps are more efficient than fans in moving large quantities of heat.

Water however can not be directly dumped into a space through a diffuser and require a more sophisticated delivery means. These employ a variety of delivery devices, including baseboard radiators, convectors, unit heaters, fan coil units and radiant floors for heating applications. Fan coil units are used for cooling applications.

Figure below shows a schematic of space heating system with a mixture of radiators and underfloor heating. The schematic also shows provision of hot water storage for plumbing use.

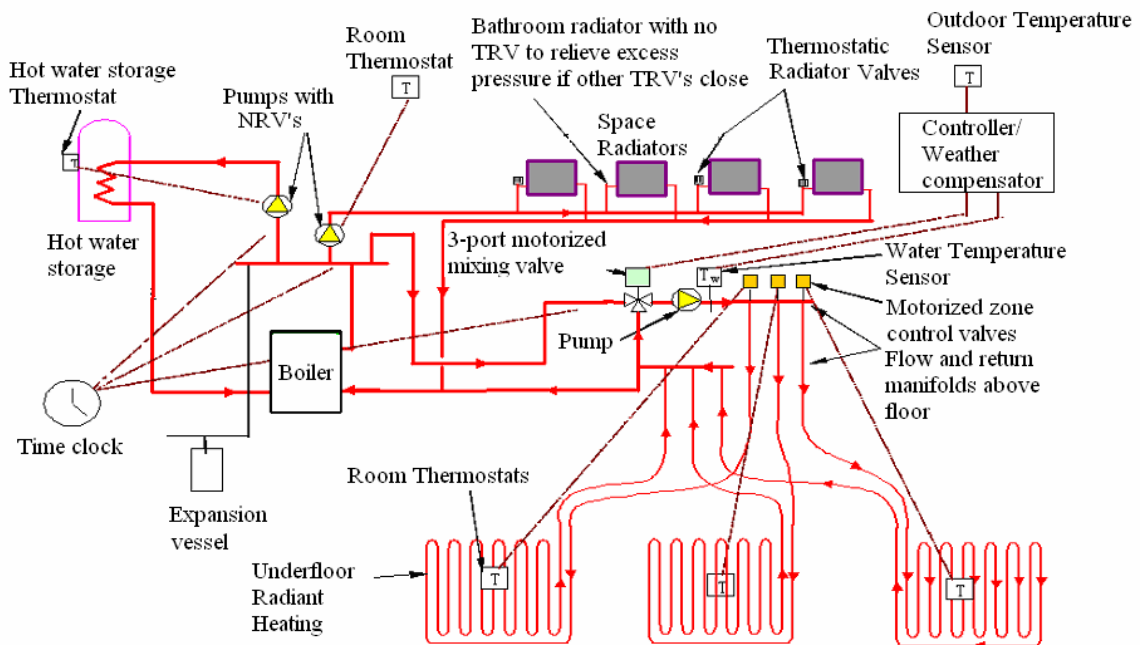

Hydronic Heating System with Controls

Refer section 7 "Hydronic Distribution" for further details on all-water systems.

## Choosing the Right System

It is not possible generally to say when some particular type of cooling system should be chosen or not. In most cases, it is possible to choose between several systems, all of which will work satisfactorily from a technical viewpoint.

Other than the first cost and operational considerations, the decisive factor in selecting all –air or all-water system is that all-air cooling requires more space for the running of ventilation ducts than does an all-water system.

In an all-water system, the ventilation system is designed purely to maintain the air quality. Therefore, the sizes of the ducts can be determined on the basis of the necessary hygiene ventilation, while an all-air cooling system requires them to be dimensioned on the basis of the maximum cooling power required, which calls for higher air flow rates. Due to lack of space, it can be almost impossible to install an all-air cooling system in buildings that have previously had no cooling system. In such cases, all-water cooling systems must be installed. There is usually space above the false ceilings to install the water pipes needed for distribution of hot/cold water throughout the building.

---



## SECTION – 7 HYDRONIC DISTRIBUTION: PIPING AND PUMPS

Hydronic system refers to the chilled or hot water distribution system from a chiller or heating boiler through a network of pipes to radiators, finned baseboard radiation, radiant floor heat tubing, fan coil or an air handler that contains a hot water/chilled water coil.

Hydronic system is NOT a system of choice for cooling equipment because of condensation/corrosion concerns. Hydronic systems are particularly preferred for heating equipment, because it provides additional benefits that the forced air heating system can't offer. In addition to the advantages of less space and much higher heat conveying capability to longer distances, the hot water systems provides exceptional comfort levels. The occupants can also enjoy the benefits of heated floors, warm towels, and abundant hot water for showers, bath and laundry.

### Type of Hydronic Piping Systems

Piping systems supply hot water and chilled water for heating and cooling applications. The hydronic piping in HVAC applications may be classified as two pipe, three pipe or four pipe systems.

**Two-Pipe:** Two-pipe systems use a supply and return piping network to distribute chilled water to the zones. The two-pipe changeover system allows hot water to be circulated during the heating season. The system cannot supply both heating and cooling simultaneously, and when both are required, the system usually is operated in cooling mode and zonal space heaters are employed.

Note that the water flow rate required for heating is much low than the chilled water flow. The piping and pumping is sized for the maximum flow of chilled water. Using the same infrastructure of piping shall result in very low velocities during heating. To overcome this if not all, 50% of pumps may need to be operative. Energy is wasted in terms of pumping cost. It is better to use 4-pipe system and lower flow rates with smaller pumps.

**Three- Pipe System:** Three pipe systems have separate chilled and hot water supplies with a common return. These systems are rarely used because they consume more energy due to excessive mixing of the chilled and hot water in the common return.

**Four-Pipe:** Four-pipe systems provide two independent water systems - one dedicated to chilled water and one to hot water i.e. four-pipe systems have a cold water supply, cold water return, warm water supply and warm water return. Although more expensive than two-pipe systems to install, they have simpler operation, and can provide both heating and cooling during the entire year.

### **Hydronic Loops**

In boiler hydronic loops there are different ways to arrangement the piping. Some piping arrangements require more pipe upon initial installation but easier to balance and provide even heat throughout all the radiators or baseboards.

### **Hydronic Piping Loops**

The hydronic piping can be set as one pipe or two pipe loop.

The One – pipe series loop uses less pipe than any other hydronic piping arrangement but you need bigger radiators or longer baseboards at the end of the loop because this part of the loop will have less heat. The radiators or baseboards at the beginning of the loop use most of the heat thus the reason for the larger radiators and baseboards at the end of the loop. There is also a larger temperature drop in this type of loop between the supply and the return versus other types of hydronic piping arrangements. The near boiler piping may need to be modified to prevent large delta T between supply and return.

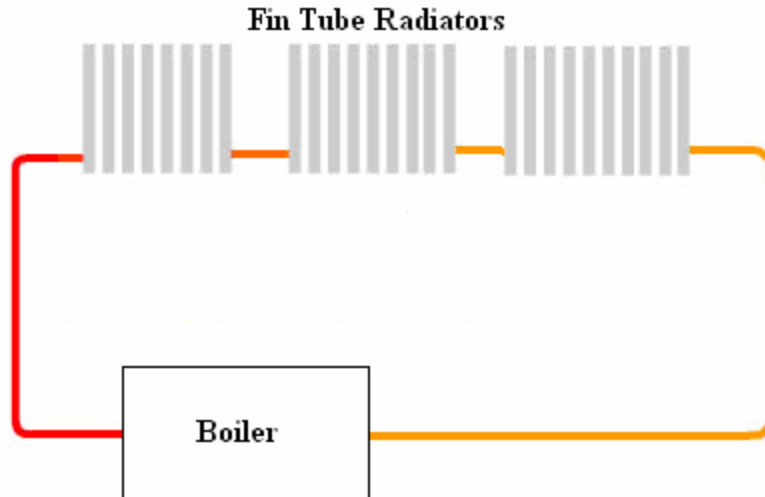

**ONE PIPE SERIES HYDRONIC LOOP**

### **Two Pipe Direct Return Hydronic Loop**

The Two – pipe direct return loop utilizes more pipe than the one pipe series loop but all radiators and baseboards receive the same temperature of water therefore it is more even heat than in all the radiators and/or baseboards than the one pipe series loop. Another advantage of two pipe direct return loop over the one pipe series loop is that it can be zoned. Zoning gives you more control over where and when you want heat and this can save you money on the cost of heating. As with many hydronic loop systems the two pipe direct return needs balancing valves. The near boiler piping may need to be modified to prevent large delta T between supply and return.

### **Two Pipe Reverse Return Hydronic Loop**

The Two – pipe reverse return loop uses more pipe than the two pipe direct return hydronic loop but the flow is more balanced and even than the two pipe direct return hydronic loop. All baseboards and radiators receive the same temperature of water so is the same as the two pipe direct return but an advantage over the one pipe series hydronic loop. The two pipe reverse return hydronic loop can also be zoned offering you savings on your heating bill by taking advantage of hydronic loop zoning and large pressure drop.

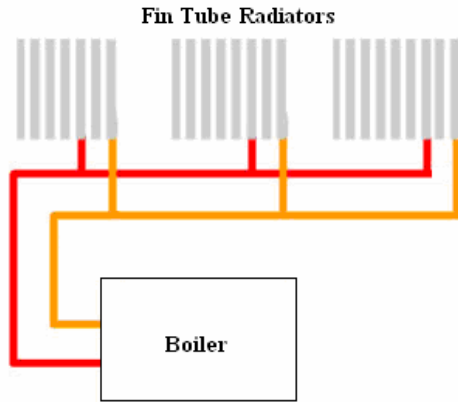

TWO PIPE DIRECT RETURN

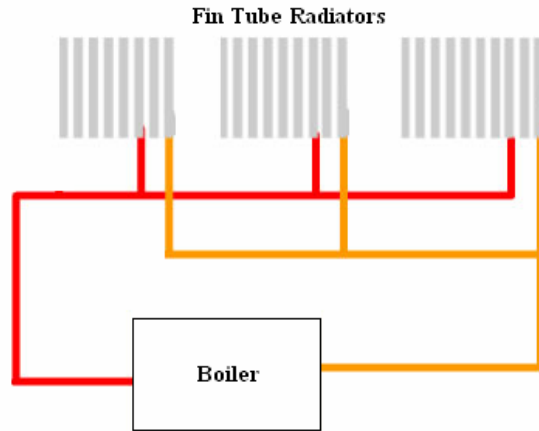

TWO PIPE REVERSE RETURN

### Hydronic Pumps

The HVAC system uses centrifugal pumps for chilled water and hot water circulation. End suction pumps are preferred for chilled water and cooling water supply. Higher flow rates are better served by double suction pump in which axial forces tend to balance one another.

The quantity of liquid discharged by the pump is almost always measured in gallons per minute (gpm). Pressure developed by a centrifugal pump is specified as head in feet of liquid.

$$h = (2.31 * P) / s$$

Where

- s=specific gravity of the liquid compared to water (water at 60/60°F = 1.00)
- h=head in feet
- P=pressure in psi

The head developed by a centrifugal pump is a function of the impeller diameter and the speed of rotation (rpm).

Maximum head that can be developed by a centrifugal pump is when the discharge valve is tightly closed and the pump is discharging zero capacity into the system. This is

known as the *shut-off* head of the pump. Since there is a pre-determined maximum pressure that the pump can develop and this pressure is taken into account by the designer, centrifugal pumps do not require relief valves or other unloading mechanizers that are otherwise necessary for the positive displacement type pumps. The maximum **shut-off** head  $h$  of any centrifugal pump can be very closely calculated by the formula:

$$h_x = \left[ \frac{D \times N}{1840} \right]^2$$

Where

- $D$  = outside diameter of the impeller inches
- $N$  = rpm

### Selecting a Pump

Check the equation:

$$\text{Pump HP} = \frac{\text{Flow (GPM)} \times \text{Head (ft)} \times \text{Specific Gravity}}{3960 \times \text{Efficiency}}$$

In making a choice of pumping systems, engineers put emphasis on the efficiency. While this is OK to have the maximum possible efficiency, one must carefully look at other part of the formula; viz. the pump flow and the head. These two parameters are often neglected. The true energy savings can be found from the correct sizing of parameters (TDH in ft x flow in GPM). For example, a pump efficiency of 70% will correlate to a system efficiency of 35%, if the pump is selected and operated at twice required pump head. If the flow requirements were similarly specified, system-pumping efficiency would decrease to the order of 17.5%.

As a generality, the larger the pump, the higher is the efficiency. While it is true that the large pumps offer higher efficiency, don't be misguided by this generic statement. It will almost always be true that a smaller pump matched to the system will operate at lowest cost-even though its efficiency as a pump is lower.

The pumps best efficiency point (B.E.P.) is between 80% and 85% of the shut off head. At this point there is little to no radial thrust on the impeller. Also the "power in" is closest to the "power out".

### **Change of Performance**

The so-called laws of affinity relating to centrifugal pumps are theoretical rules that apply to the change in performance of a centrifugal pump by a change in the speed of rotation or a change in the impeller diameter of a particular pump. It should always be remembered in using these laws of affinity that they are theoretical and do not always give exact results as compared with tests. However, they are a good guide for predicting the hydraulic performance characteristic of a pump from a known characteristic caused by either altering the speed of rotation or the outside diameter of the impeller. The laws of affinity may be stated as follows:

At a constant impeller diameter

- Capacity varies directly as the speed
- Head varies directly as the square of the speed
- Horsepower varies directly as the cube of the speed

If you double the speed of a pump you will get twice the capacity, four times the head and it will take eight times the horsepower to do it. Variable volume pumping systems should be considered for HVAC application.

Check the equation:

$$\text{Cooling load (BTUH)} = \text{Flow (GPM)} \times 500 \times (T_i - T_o)$$

Where

- $T_i$  &  $T_o$  is the inlet and outlet temperature across heat exchanger (chiller or condenser).

As the temperature range across the heat exchanger (chiller or condenser) is increased, the flow rate is decreased for the same capacity. Smaller flow means smaller pipes & pumps; this equates to capital savings.

### **Parallel or Series Arrangement**

The number of primary chilled water and condenser water pumps shall correspond to the number of chillers and a separate pump shall be designed for each condenser water circuit. Pumps piped in series must have the same capacity (impeller width and speed).

**Series pumping** is most effective when the system head pressure curve is steep. When the head pressure is not a constraint, **parallel pumping** is preferred. Pumps piped in parallel must have the same head (impeller diameter and speed). Parallel pumping provides high degree of redundancy and standby capacity. When one pump is out of operation, the other pump continues to pump water through the system.

---

## **SECTION – 8 ANNUAL ENERGY USE CALCULATIONS**

As a part of the design process, we are often interested in finding annual operating costs for HVAC systems. In addition to being used for budget planning, such analysis may be used in the evaluation of alternative system selection.

Energy requirements and fuel consumption of HVAC systems will, of course, depend strongly on many factors: weather variables (sunshine, wind, humidity and temperature), the building operating patterns, and thermal characteristics that may vary with time.

Many of these factors are not predictable, so that all such methods are strictly estimates. It is difficult to foresee accurately how these factors will vary and the way in which they will interact. Records of past operating experience, when available, provide the most reliable basis for accurately predicting future energy requirements. When past energy records are not available, some form of calculation is necessary.

### **Balance point temperature**

Balance point temperature is the value of outdoor temperature at which internal heat sources are equal to heat losses through wall i.e. building's heat loss matches its gains at

this point. At balance point, space heating is not required until outdoor temperature drops to a point at which building's heat gains are insufficient to provide the heating needs. The formula for determining balance point temperature is:

$$T_b = T_i - (Q_i / UA)$$

Where

- $T_b$  = balance point temperature
- $T_i$  = average indoor temperature over 24 hrs. in winter
- $Q_i$  = rate of internal heat gain (BTUH/sqft)
- $UA$  = rate of heat loss (BTUH/sqft/°F)

Note - It is necessary to understand the concept of balance point temperature in order to grasp the concept of degree days covered below.

### **Degree day method for energy use computations**

A “degree day” is a measure of the average temperature’s departure from a human comfort level of 18 °C (65 °F). The concept of degree days is used primarily to evaluate energy demand for heating and cooling services. In the United States, for example, degree day indicators are widely used in weather derivatives, energy trading, and weather risk management.

One degree-day corresponds to a difference of 1° F between the outside mean temperature and the balance point temperature. Monthly heating degree days are defined as the number of degrees the average monthly temperatures are below the balance point temperature multiplied by the number days in the month. Annual degree days are an accumulation of the monthly degree days.

There are two main types of degree days: heating degree days (HDD) and cooling degree days (CDD). Both types can be Celsius based or Fahrenheit based.

### **Heating degree days (HDD)**



Heating Degree Days (HDD) for a particular climate is obtained by subtracting each day's mean outdoor dry bulb temperature from the balance point temperature; this result is the number of HDDs for that day. For example, if the maximum and minimum outdoor dry bulb temperatures of a place were 80°F and 20°F respectively, and the balance point temperature were 65°F, then HDD of the place for that particular day would have been  $65 - [(80 + 20) / 2] = 15$ . If the mean outdoor dry bulb temperature is equal to or higher than the balance point temperature, then the HDD would be equal to 0.

The concept originated with the observation that demand for natural gas for heating does not pick up until the average daily temperature falls below 65°F. Instead of the average daily temperature, in practice the highest and lowest outside temperatures during a 24-hour day are averaged. The result, subtracted from 65, is the number of heating degree-days for that day. The degree-days for longer periods are found by adding the degree-days for the individual days.

#### Degree Days and Annual Heating loss

A preliminary estimate of annual heating load, using degree day method, can be obtained by the following formula:

$$Q = PHL \times 24 \times HDD / \Delta T$$

Where

- Q = Annual heating load in Btu
- PHL = peak heating load (heat loss) in Btu/hr
- HDD = heating degree days
- $\Delta T$  = temperature difference, °F

#### **Fuel consumption by heating units**

The amount of fuel required for annual heating can be calculated using the formula:

$$F = Q / (e \cdot FHC)$$

Where

- F = Quantity of fuel consumed (in gallon, MCF, kW, etc.) per year for heating
- H = Annual heating load in BTUH
- e = efficiency of the heating unit (coefficient of performance in case of a heat pump)
- FHC = fuel heat content (BTU)

### **Cooling degree days (CDD)**

Cooling degree days (CDD) are used for calculations relating to the cooling of buildings. For example, CDD can be used to normalize the energy consumption of buildings with air conditioning. Cooling degree-day figures also come with a base temperature, and provide a measure of how much, and for how long, the outside temperature was *above* that base temperature.

#### **Calculation of cooling degree days:**

Cooling Degree Days (CDD) for a particular climate is obtained by subtracting the balance point temperature from each day's mean outdoor dry bulb temperature from the balance point temperature; this result is the number of CDDs for that day. For example, if the maximum and minimum outdoor dry bulb temperatures of a place were 90°F and 60°F respectively, and the balance point temperature were 65°F, then CDD of the place for that particular day would have been  $[(90+60)/2]-65 = 10$ . If the mean outdoor dry bulb temperature is equal to or lower than the balance point temperature, then the CDD would be equal to 0.

Note - The cooling degree-day is less used and less firmly defined.

#### **Annual cooling load**

A preliminary estimate of annual heating load, using degree day method, can be obtained by the following formula:

$$Q = PCL * 24 * CDD / TD$$

Where

- Q = Annual cooling load in BTUH
- PCL = peak cooling load (heat gain) in BTUH
- CDD = cooling degree days
- TD = temperature difference (deg F)

### **Energy consumption by cooling units**

The amount of fuel required for annual cooling can be calculated using the formula:

$$F = Q / (\text{SEER} * 1000)$$

Where

- F = Electrical energy required in kWh per year for cooling
- Q = Annual cooling load in BTUH
- SEER = Seasonal Energy Efficiency Ratio of the cooling unit (Quantity of heat removed in BTUH for an input of 1 watt)

**Energy cost:** \$ = F \* cost per unit

---