



PDHonline Course M329 (5 PDH)

HVAC Pumps Characteristics and Energy Efficiency

Instructor: A. Bhatia, B.E.

2020

PDH Online | PDH Center

5272 Meadow Estates Drive
Fairfax, VA 22030-6658
Phone: 703-988-0088
www.PDHonline.com

An Approved Continuing Education Provider

HVAC Pumps Characteristics and Energy Efficiency

A. Bhatia, B.E.

HVAC systems have changed dramatically over the past decades. Code compliance, environmental concerns, cost issues, developments in technology and equipment — these are among the key factors driving changes in HVAC designs. In many cases, tried-and-true solutions are falling by the wayside, replaced by innovative approaches to old problems.

In chilled water HVAC plant, the pumps' role is to provide sufficient pressure to move the fluid through the chiller and condenser water distribution system at the desired flow rate. The pumps are broadly classified in two types: 1) centrifugal pump and 2) positive displacement pump. In HVAC services, centrifugal pumps are popular because of its design simplicity, high efficiency, wide range of capacity and head, smooth flow rate, low operating costs, varied sizes, and ease of operation and maintenance. The positive displacement pumps are only used for chemical dosing in cooling water system.

This course will focus on centrifugal pumps for HVAC applications.

Section – 1

PUMPING SYSTEM OVERVIEW

Centrifugal Pumps

Centrifugal pumps in chilled water HVAC plants are used for circulating chilled water through chillers and air handling units in closed loop and for circulating cooling water through condensers and cooling tower in open loop. All centrifugal pumps use an impeller, which is basically a rotating wheel, to add energy to a fluid. Figure below illustrates a cross-section of a typical centrifugal pump.

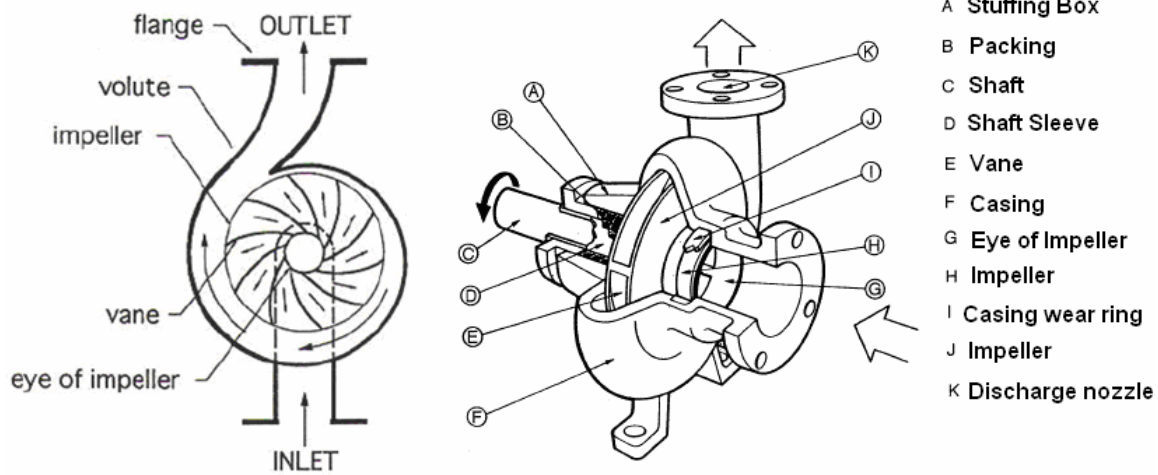

Fluid enters the inlet port at the center of the rotating impeller, or the suction eye. As the impeller spins in a counter-clockwise direction, it thrusts the fluid outward radially, causing centrifugal acceleration. As it does this, it creates a vacuum in its wake, drawing even more fluid into the inlet. Centrifugal acceleration creates energy proportional to the speed of the impeller. The faster the impeller rotates, the faster the fluid movement and the stronger its force. This energy is harnessed by introducing resistance.

Remember, a pump does not create pressure; it only provides flow. All pumps used in hydronic cooling or heating systems have an operating characteristic in which the flow they produce depends on the resistance they are working against. The resistance is generated by the friction of the fluid moving through the piping systems. The greater this resistance is, the slower a given pump can move fluid through the piping system.

Centrifugal pumps can be segmented into groups based on design, application, service, etc. These pumps can belong to several different groups depending on their construction and application. The following examples demonstrate various segments:

Industry standards:

- Hydraulic Institute (HI) standards
- ANSI pump - ASME B73.1 specifications (chemical industry)
- API pump - API 610 specifications (oil & gas industry)

- DIN pump - DIN 24256 specifications (European standard)
- ISO pump - ISO 2858, 5199 specifications (European standard)
- Nuclear pump - ASME specifications
- UL/FM fire pump - NFPA specifications

Number of impeller/s in the pump:

- Single stage - pump has one impeller only; for low head (pressure) service.
- Two-stage - pump has two impellers in series; for medium head service.
- Multi-stage - pump has three or more impellers in series; for high head service.

Impeller suction:

- Single suction - pump with single suction impeller (suction eye on one side of the impeller only). This design is subject to higher axial thrust imbalances due to flow coming in on one side of impeller only.
- Double suction - pump with double suction impeller (suction eyes on both sides). This design has lower NPSHR than single suction impeller. Even though this pump is hydraulically balanced, it is susceptible to uneven flow on both sides of the impeller if the suction piping is not installed properly.
- Pumps with more than one impeller are labeled according to the design of the first stage impeller.

Type of volute:

- Single volute - single lipped volute which is easy to cast and is used with low capacity pumps. Pumps with single volute design maintain higher radial loads.
- Double volute - pump volute has dual lips located 180 degrees apart resulting in balanced radial loads; most centrifugal pumps are of double volute design.

- Triple volute - has lips (cut-waters) 120 degrees apart for exceptional radial thrust balancing and excellent performance across the range of the pump.

Shaft position:

- Horizontal - pump with shaft in horizontal plane – it is popular due to ease of servicing and maintenance.
- Vertical - pump with shaft in vertical plane; used when space is limited, or when pumping from a pit or sump to increase the available NPSH.

Orientation of case-split:

- Horizontal split - pump case is split horizontally into two pieces - the upper case and lower case. This type of pump is usually limited to temperatures up to 450 degrees F. Hotter applications can cause shaft misalignment due to uneven thermal expansion.
- Vertical or radial split - pump case is split vertically and the split parts are known as a case and cover. These pumps are used for high temperature applications due to even thermal expansion of the shaft.

Shaft connection to driver:

- Close-coupled or integral design - Used for light duty service, the impeller is mounted on the driver shaft with a special design. The pump-driver assembly is very compact, lightweight, and inexpensive.
- Long-coupled - the pump and driver shafts are connected using a flexible coupling. A spacer coupling can be used to allow the removal of seals without disturbing the secured ends of the pump.

Many factors go into determining which type of pump is suitable for an application. Often, several different types meet the same service requirements.

HVAC Pump Types:

The most of the pumps used in the HVAC industry are single stage (one impeller) volute-type pumps that have either a single inlet or a double inlet (double suction). Double suction pumps are used in high volume applications; however either a single inlet or double inlet pump is available with similar performance characteristics and efficiencies. The centrifugal pumps for building services applications should be in accordance to Hydraulic Institute Standards and all hydronic piping is in accordance with ASME B 31.9 "Building Services Piping". All electric motors and components shall comply with NEMA standards.

Close-Coupled, Single Stage, End-Suction Pump: The closed-coupled pump has the impeller mounted on a motor shaft extension. The pump is mounted on a horizontal motor supported by the motor foot mountings.

A solid concrete pad is required for mounting. This compact pump has a single horizontal inlet and vertical discharge. The motor and pump can not be misaligned and they take up less floor space than flexible-coupled pumps. However, to replace the special motor with an extended shaft that is used can be difficult to get after a breakdown.



Specifications

- All wetted surfaces shall be non-ferrous materials
- Body: Cast iron with bronze or stainless steel – fitted construction
- Shaft: Stainless steel; metal impregnated carbon thrust bearing
- Motor: Non-overloading at any point on pump curve, open, drip-proof, oil-lubricated journal bearings, resilient mounted construction, built-in thermal overload protection on single phase motors

- Coupling: Self-aligning, flexible coupling
- Impeller: Bronze or stainless steel enclosed type, hydraulically and dynamically balanced, and keyed to shaft

Frame-Mounted, End-Suction Pump on Base Plate: The motor and pump are mounted on a common rigid base plate for horizontal mounting. Mounting requires a solid concrete pad. Base-mounted pumps shall be placed on minimum of 4" high concrete base equal or greater than 3 times total weight of pump and motor, with anchor bolts poured in place. The motor is flexible-coupled to the pump shaft. For horizontal mounting, the piping is horizontal on the suction side and vertical on the discharge side. The flexible-coupled shape allows the motor or pump to be removed without disturbing the other. However, the flexible coupling requires very careful alignment and a special guard. The flexible-coupled pump is usually less expensive than the close-coupled pump.



Specifications

- Casing: Cast iron, ANSI flanges rated for the working pressure of the piping system, and tappings for gage and drain connections
- Shaft: Steel with replaceable shaft sleeve
- Shaft Sleeves: 316 Stainless Steel with Buna O Ring Sealing between the impeller and the hub. Threaded to tighten when rotating in normal service direction

- Motor: Non-overloading at any point on pump curve, open, drip-proof, oil-lubricated journal bearings, resilient mounted construction, built-in thermal overload protection on single phase motors
- Impeller Ring: Bronze. Easily replaceable
- Construction: Bronze fitted
- Seal: Mechanical Seal with ceramic seat
- Baseplate: Cast iron or steel

Double-Suction Split Case Pump: The water is introduced on each side of the impeller and the pump is flexibly connected to the motor. Typically, motor and pump are mounted on a common rigid base plate for horizontal mounting. Double-suction pumps are preferred in application over 1000 GPM because it's very high efficiency and can be opened, inspected and serviced without disturbing the motor, impeller or the piping connections. The pump case can be split axially (parallel to the shaft) or vertically for servicing. This pump takes more floor space than end suction pumps and is more expensive.



Specifications

- Casing: Cast iron, ANSI flanges rated for the working pressure of the piping system, and tapping for gage and drain connections
- Shaft: 316 Stainless Steel
- Shaft Sleeves: Bronze or Stainless Steel

- Motor: Non-overloading at any point on pump curve, open, drip-proof, oil-lubricated journal bearings, resilient mounted construction, built-in thermal overload protection on single phase motors
- Impeller: Bronze
- Seal: Mechanical Seal with ceramic seat
- Drive: Flexible coupling with coupling guard
- Baseplate: Cast iron or steel

Vertical In-Line Pumps: It is also a closed-coupled pump that has the motor mounted on the pump casing. These pumps have the suction and discharge connections arranged so they can be inserted directly into a pipe. Mounting requires adequately spaced pipe hangers and, sometimes, a vertical casing support. In the past, in-line pumps were used almost exclusively for small loads with low heads but now the widest range of sizes is available. Considerable space saving can be achieved using in-line pumps but extra care must be taken to assure that pipe stress are not transferred to the pump casing.



Specifications

- Casing: Cast iron, ANSI flanges rated for the working pressure of the piping system, and tapping for gage and drain connections

- Shaft: 316 Stainless Steel
- Shaft Sleeves: Bronze or Stainless Steel
- Motor: Non-overloading at any point on pump curve, open, drip-proof, oil-lubricated journal bearings, resilient mounted construction, built-in thermal overload protection on single phase motors
- Impeller Ring: Bronze, statically and dynamically balanced, and keyed to shaft
- Seal: Mechanical Seal with ceramic seat
- Coupling: Axially split spacer coupling

Recommendations

For HVAC applications, evaluate system conditions and select the optimum pump type and configuration based on efficiency and pump characteristics. In general following recommendations are useful:

1. Close-coupled end suction pumps or In-line circulating pumps (up to 50 GPM).
2. Base-mounted end suction pumps for circulating systems with flow rates between 50 and 500 GPM.
3. Horizontal split case, double-suction pumps for applications with flow rates exceeding 500 GPM.
4. Vertical in-line pumps shall be considered for applications with limited floor space.

Steps for Proper Pump Selection

1. Determine use and location of pump
2. Determine end use requirements - flow and head
3. Select possible configurations – consider the maintenance footprint
4. Review manufacturer's pump range charts to narrow search

5. Review individual pump curves and evaluate
 - Operation point relative to BEP
 - Horsepower requirement through end of curve
 - Efficiency
 - NPSH requirement
 6. Size of pump impacts:
 - Purchase cost
 - Yearly operation cost (poor operating efficiency)
 - Fluid velocity (noise)
 7. Select a pump that is either at or to the left of BEP for optimal performance
-

Section – 2

PUMP SYSTEM CHARACTERISTICS

Pressure, friction and flow are three important characteristics of a pump system. Pressure is the driving force responsible for the movement of the fluid. Friction is the force that slows down fluid particles. Flow rate is the amount of volume that is displaced per unit time. The unit of flow in North America, at least in the pump industry, is the US gallon per minute, USGPM. Other fluid properties are listed; some although may not be relevant for HVAC but still important to understand the pumping characteristics.

Fluid Properties

1. **Acidity/alkalinity (pH) and chemical composition** - Corrosive and acidic fluids can degrade pumps, and should be considered when selecting pump materials. In HVAC applications, the fluid used is typically water or glycol.
2. **Operating temperature** - Pump materials and expansion, mechanical seal components, and packing materials need to be considered with pumped fluids that

are hotter than 200°F. In HVAC applications chilled water is usually supplied at 40 to 44°F, the condenser cooling water to cooling tower is at 100 to 105°F and the hot water application is at 140 to 250°F.

3. **Viscosity** – A measure of a liquid's resistance to flow i.e. how thick it is. Viscosity usually varies greatly with temperature with viscosity decreasing as temperature rises. Viscous liquids tend to reduce capacity, head, and efficiency while increasing the brake HP.

Centrifugal pumps are generally not suitable for pumping highly viscous liquids. Normally, small and medium sized centrifugal pumps can be used to handle liquids with viscosities up to 2000 SSU. Viscosities over 2000 SSU are usually better suited for positive displacement pumps. Note, water has a viscosity of approximately 31 Saybolts seconds universal (SSU) at 60°F.

4. **Density** - The density of a liquid is its weight per unit volume. Fresh water has a density of 62.4 pounds per cubic foot (lbs /cu. ft.) or 8.34 pounds per gallon (lbs/gal). A liquid has many different numerical terms to describe its density but only one specific gravity (SG).
5. **Specific Gravity** - Specific gravity (SG) is a relative measure of a fluid's density as compared with water at a standard temperature (most often 60°F). The SG of water at 60°F is 1.0. If the density of the fluid is greater than water, its specific gravity will be greater than 1. SG of 1.2 means its density is 20% greater than water. The SG of liquid does not affect the performance of a pump but it affects the energy required to lift and move the fluid, and must be considered when determining pump power requirements. Assuming the viscosity of a liquid is similar to that of water the following statements will always be true regardless of the specific gravity:
 - A centrifugal pump will always develop the same head in feet regardless of a liquid's specific gravity.
 - Pressure will increase or decrease in direct proportion to a liquid's specific gravity.
 - Brake HP required will vary directly with a liquid's specific gravity.

6. **Specific Weight** - The specific weight of a fluid can be determined by multiplying the fluid density by the SG of the fluid relative to the density of water (8.34 lbs/gal). Gasoline with a SG = .72, weighs approximately 6.0 lbs /gal (.72 x 8.34 lbs/gal).
7. **Solids concentrations/particle sizes** - The quantities and properties of particulates in a system fluid also affect pump design and selection. Some pumps cannot tolerate much debris. And the performance of some multistage centrifugal pumps degrades significantly if seals between stages become eroded. Other pumps are designed for use with high-particulate-content fluids. When pumping abrasive liquids such as industrial slurries, selecting a pump that will not clog or fail prematurely depends on particle size, hardness, and the volumetric percentage of solids. Not a concern with chilled water system but open systems such as cooling tower circuit may get external contaminants.
8. **Vapor Pressure** - A fluid's vapor pressure is the force per unit area that a fluid exerts in an effort to change phase from a liquid to a vapor, and depends on the fluid's chemical and physical properties. It can be thought of as the pressure at which the liquid molecules begin to separate, forming a vapor. At 60°F, the vapor pressure of water is approximately 0.3psia and at the boiling point of water, (212°F), the vapor pressure is equal to atmospheric pressure, 14.7psia.

End Use Requirements – System Flow and Head

Two basic parameters for specifying pumps are system flow and head. It is unlikely that you buy a centrifugal pump off the shelf, install it in an existing system and expect it to deliver exactly the flow rate and head you require. The flow rate and head that you obtain depends on the physical characteristics of your system such as friction, which depends on the length and size of the pipes and elevation difference. The pump manufacturer has no means of knowing what these constraints will be. This is why buying a centrifugal pump is more complicated than buying a positive displacement pump which will provide its rated flow no matter what system you install it in.

The steps to select a centrifugal pump are: 1) determine the capacity and 2) determine head.

Determine the capacity

Capacity means the flow rate with which liquid is moved or pushed by the pump to the desired point in the process. It is commonly measured in gallons per minute (GPM). In chilled water systems, the flow rate required for a given heat load is determined by following equation:

$$\text{CWFR} = \frac{\text{HL}}{\text{D} \times 8.34 \frac{\text{min}}{\text{hr}} \times \text{SG} \times \text{SH} \times \Delta T}$$

Where:

- CWFR: Chilled water flow rate (gal/min)
- HL: Heat load (BTU/hr).....or chiller capacity
- D: Liquid density (water density = 8.34 lb/gal)
- SG: Liquid specific gravity (water specific gravity = 1)
- SH: Liquid specific heat (water specific heat = 1 BTU/lb-°F)
- ΔT : Chilled Water temperature differential [i.e. T return water - T supply water] in °F

Simply stated the water flow rate is given by equation:

$$\text{GPM} = \frac{\text{BTU/hr}}{500 \times \Delta T (\text{°F})}$$

Since, the HVAC designer's converse more in terms of tons of refrigeration, the equation can be simplified as:

$$\text{GPM/Ton} = \frac{12000}{500 \times \Delta T (\text{°F})}$$

OR

$$\text{GPM/Ton} = \frac{24}{\Delta T (\text{°F})}$$

Note that 1 ton of refrigeration = Heat extraction rate of 12000 BTU/hr

Example

What will the pump flow rate through a chiller rated at 1000 tons and operating at 42°F supply water temperature and 54°F return water?

Chiller capacity = 1000 tons or 12,000,000 Btu/hr

Supply water temperature = 42°F

Return water temperature = 54°F

ΔT in distribution system = 12 degrees ----- [54°F – 42°F]

The water flow rate is given by:

$$\text{GPM} = \frac{\text{BTU/hr}}{500 \times \Delta T (^{\circ}\text{F})}$$

Water flow rate = 12,000,000 / (500 x 12) = 2000 GPM

Example

How many tons of cooling is served by a 6,000 GPM operating at 42°F supply water temperature and 54°F return water?

GPM = 6,000

Supply water temperature = 42°F

Return water temperature = 54°F

ΔT in distribution system = 12 degrees ----- [54°F – 42°F]

LFR = 24/ ΔT = 24/12 = 2 GPM/Ton

Tons Cooling = GPM / (24/Delta T) = 6,000/2 = 3,000 tons

As liquids are essentially incompressible, the capacity is directly related with the velocity of flow in the suction pipe. This relationship is as follows:

$$\text{GPM} = 449 * V * A$$

Where

- V = Velocity of flow in feet per second (fps)
- A = Area of pipe in ft^2

The design pump capacity, or desired pump discharge in gallons per minute (GPM) is needed to accurately size the piping system, determine friction head losses, construct a system curve, and select a pump and drive motor. Process requirements may be met by providing a constant flow rate (with on/off control and storage used to satisfy variable flow rate requirements), or by using a throttling valve or variable speed drive to supply continuously variable flow rates.

Head

A pump does not create pressure, it only creates flow!

Pressure is a measurement of the resistance to flow. In Newtonian fluids (non-viscous liquids like water or gasoline) we use the term head to measure the kinetic energy which a pump creates.

"Head" is not the same as pressure. Head is a measurement of the height of a liquid column which the pump could create resulting from the kinetic energy the pump gives to the liquid (imagine a pipe shooting a jet of water straight up into the air, the height the water goes up would be the head). Head is measure in units of feet while pressure is measured in pounds per square inch, and is independent of pressure or liquid density.

To convert head to pressure (psi) the following formula applies:

$$\text{Head (ft)} = \text{Pressure (psi)} \times 2.31 / \text{specific gravity}$$

For practical pump applications, the term **head** is used. *The main reason for using head instead of pressure* is that the pressure from a pump will change if the specific gravity (weight) of the liquid changes, but the head will not change. Since any given centrifugal pump can move a lot of different fluids, with different specific gravities, it is simpler to discuss the pump's head and forget about the pressure. *A given pump with given impeller diameter and speed will raise a liquid to a same height regardless of the weight of the liquid.*

Types of Head

The various categories of head are listed below.

Static Head - Static head is the vertical distance from the water level at the source to the highest point where the water must be delivered. It is the sum of static lift and static discharge. Static head is independent of the system discharge (GPM) and is constant for all values of discharge. However, it is possible that the static head may vary with time due to the changes in the system.

Static Suction Head - The static lift is the vertical distance between the center line of the pump and the elevation of the water source when the pump is not operating. When the liquid level is above pump centerline this number will be positive, and when it is below pump centerline this will be negative. A negative condition is commonly called a "suction lift" condition.

Atmospheric pressure, as measured at sea level, is 14.7 PSIA. In feet of head it is:

$$\text{Head} = \text{PSI} \times 2.31 / \text{Specific Gravity}$$

For Water it is:

$$\text{Head} = 14.7 \times 2.31 / 1.0 = 34 \text{ Ft}$$

Thus 34 feet is the theoretical maximum suction lift for a pump at sea level. No pump can attain a suction lift of 34 ft; however, well designed ones can reach 25 ft quite easily. Note this is true for water at 68F; for any other fluid always factor in specific gravity of the liquid being pumped. For example, the theoretical maximum lift for brine (Specific Gravity = 1.2) at sea level is 28 ft. The realistic maximum is around 20ft.

Static Discharge Head - The static discharge head is a measure of the elevation difference between the center line of the pump and the final point of use. To obtain this value, subtract the elevation of the pump or discharge pipe from the elevation of the final point of delivery.

Friction Head – This refers to the resistance in the pipe and fittings. It varies with the size, condition and type of pipe, the number and type of fittings, the flow rate, and type of liquid. The pump must add energy to the water to overcome the friction losses. As the

discharge of the system increases the velocity also increases. The friction loss increases as the square of the flow velocity. Due to the high cost of energy, it is often recommended that a user select a larger pipe size to decrease the velocity for the same discharge. This is usually economically feasible if the water velocity is more than 5 ft/sec.

Vapor Pressure Head: This is the pressure level at which a liquid will vaporize at a given temperature. This pressure rises as the temperature of the liquid rises, which also effectively reduces suction pressure head.

Pressure Head: This refers to the pressure on the liquid in the reservoir feeding the pump. It occurs when a pumping system operates in a pressurized tank. In an open system, this is atmospheric pressure.

Velocity Head - Velocity head also known as dynamic head is a measure of a fluid's kinetic energy. Velocity head is calculated using the following equation: $H_v = V^2/2g$

Where:

- H_v =velocity head ft
- V =water velocity in the system ft/sec
- g =acceleration of gravity 32.2 ft/sec²

In most installations velocity head is very small in comparison to other components of the total head (it is usually less than one foot). An increase of water velocity in the system will not usually result in large increases in velocity head. However, velocities that are too high will increase friction losses as discussed above and also may result in water hammer which should be avoided. Water hammer is a sudden shock wave propagated through the system. To avoid it, the velocity is generally maintained below 5 ft/s.

Total Head Calculations in a Pump

Total Suction Head: This reflects the reading a pressure gauge would show if it were mounted at the pump inlet. It is based on the following formula: Suction Pressure head (h_{pS}) plus Static Suction head (h_S) plus the Velocity head at the inlet (h_{vS}) minus the friction head in the suction line (h_{fS}).

Total suction head

=
Suction pressure head
+
Static suction head
+
Velocity head (at the inlet)
-
Friction head (in the suction line)

Total Discharge Head: This reflects the reading a pressure gauge would show if it were mounted at the pump outlet. It is based on the following formula:

Total Discharge Head

=
Discharge Pressure head
+
Static Discharge head
+
Velocity head at the outlet
+
Friction head in the discharge line

Total Differential Head: This is the difference between the total discharge head and the total suction head:

Total Differential Head

=
Total discharge head
+
Total suction head (with a suction lift)

Total Differential Head

=
Total discharge head
-
Total suction head (with a suction head)

In chilled water systems, pumps distribute the chilled water by creating a pressure differential (DP) between the supply and return lines. The pump head is selected to overcome the flow resistance in the supply and return lines plus the pressure differential in the chiller equipment and terminal equipment such as air handling units, fan coil units and control valves.

System Types

HVAC circulation applications are found in two configurations – closed loop and open loop. A closed-loop system recirculates fluid around a path with common beginning and end points. An open-loop system has an input and an output, as fluid is transferred from one point to another. The chilled water circulation in large air conditioning systems and hot water circulation in heating systems) are examples of closed loop applications. Chiller cooling tower flow and swimming pool filtration are examples of open loop systems.

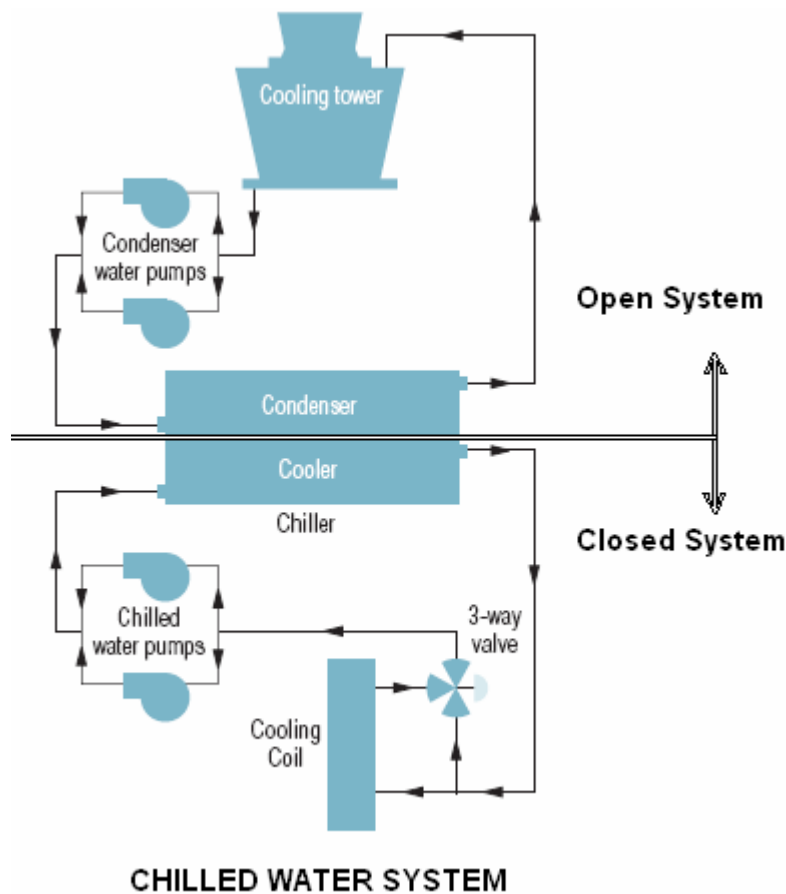

The pump head calculation depends on the type of system that the pump serves.

Circulation – Closed Loop

Central chilled water systems are configured as closed loop systems, utilizing pumps to provide circulation. Here, the fluid (chilled water) travels through a continuous closed piping system that starts and ends in the same place--- there is no break in the piping loop. The closed loop has no need for consideration of static heads for pump selection because of a balance or cancellation of static heads between the supply and return risers. The only pump head requirement for the “closed” loop is that due to flow-friction pressure drop. As you might expect, the head required to maintain flow in a closed loop decreases as flow decreases and becomes greater when flow increases. The closed systems require an expansion tank to absorb any thermal expansion of the fluid.

Circulation – Open Loop

In cooling water system using cooling towers, the fluid is exposed to a break in the piping system that interrupts forced flow at any point. In cooling towers, a break in the piping system occurs when the water exits the spray nozzles, and is exposed to air in the fill section of the tower.

The “open” circuit is different from the “closed” loop circuit in that all static heads are not cancelable. The pump must raise fluid from a low reference level to a higher level and this requires increased pump head. Open systems don't require expansion tanks, as the fluid is naturally free to undergo thermal expansion.

We will learn more about capacity (flow) and head relationships in section – 3 & 5.

Section – 3 PUMP SELECTION CONSIDERATIONS

The flow and head of a centrifugal pump depends on three (3) factors:

1. Pump Design
2. Impeller Diameter

3. Pump Specific Speed

The pumps are designed around their impellers. Flow rate is determined by the impeller geometry and its rotational speed. Pump designers manipulate the impeller vane design to achieve an optimum throughput velocity for an impeller. The throughput velocity (ft/sec) multiplied by the usable area of the impeller inlet (ft²) yields the flow rate (ft³/sec). Every impeller has one optimum design flow rate for a given speed and diameter. This is the best efficiency point of the pump. At other flow rates there will be a mismatch between the vane angle at the pump inlet and the flow rate, resulting in increased turbulence and loss of efficiency within the pump.

Specific speed identifies the type of pump according to its design and flow pattern. According to this criterion, the centrifugal pumps can be classified into three categories: radial flow, mixed flow, and axial flow.

1. Radial Flow - a centrifugal pump in which the pressure is developed wholly by centrifugal force and where the impeller discharges the liquid in the radial direction from the pump shaft centerline.
2. Mixed Flow - a centrifugal pump in which the pressure is developed partly by centrifugal force and partly by the lift of the vanes of the impeller on the liquid. It is cross between a radial and an axial flow pump design.
3. Axial Flow - a centrifugal pump in which the pressure is developed by the propelling or lifting action of the vanes of the impeller on the liquid. An axial flow pump discharges the liquid in the axial direction.

The pumps for HVAC applications are typically radial flow.

Pump Characteristic Curve

The amount of fluid a centrifugal pump moves depends on the differential pressure or head it supplies. For centrifugal pumps, there is always an inverse relationship between head and flow i.e. higher head mean lower flows and lower head yields higher flows. This allows centrifugal pump to operate under broad range of conditions.

The pump characteristic curve provides the relationship between total head and flow rate as illustrated in figure below:

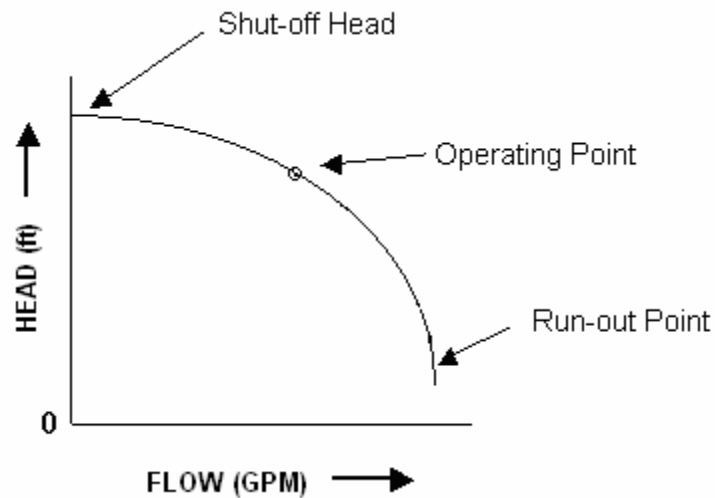

There are three important points on this curve.

1. Shut-off head: The pump curves start at a high point on the left side of the graph called the “shut off head.” This point represents a condition where the pump is running but no flow is passing through it. This could occur, for example, if a valve in the piping loop were completely closed. Under such conditions, the impeller of the pump is simply churning the same volume of fluid inside the volute of the pump. Although most modern circulators can tolerate this condition for a short time, it is not a normal way to operate a pump. It’s like pushing down on the gas pedal of a car while holding down on the brake peddle at the same time. The pump will be noisy and vibrate excessively at this point. The pump will consume the least amount of power at this point.
2. Operating Point: As some flow is allowed to pass through the circulator, the amount of head energy added to each pound of fluid decreases. That’s why the pump curve slopes downward to the right. The greater the flow through the pump the smaller the amount of head added.

It’s helpful to remember that a pump always “operates on its pump curve.” This simply means that the tradeoff between added head energy and flow rate can always be shown by a point on the pump curve. Not surprisingly, this point is called the

“operating point.” As you open the discharge valve to allow more flow passes through the pump the operating point will “slide down” the pump curve. You might think that if you opened the valve all the way that the operating point would slide all the way to the other end of the pump curve. In reality this will never happen because the valve and piping in the loop always generates some friction as long as there is flow. This friction results in head loss from the fluid. To keep it flowing, the pump must add the same amount of head energy back to the fluid.

The manufacturers also specify the location of operating point on the curve, where the pump is most efficient. This is called “best efficiency point” (BEP). "BEP" - Best Efficiency Point is not only the operating point of highest efficiency but also the point where velocity and therefore pressure is equal around the impeller and volute. As the operating point moves away from the BEP, the velocity changes, which changes the pressure acting on one side of the impeller. This uneven pressure on the impeller results in radial thrust which deflects the shaft causing, excess load on bearings, excess deflection of mechanical seal or uneven wear of gland packing or shaft / sleeve. All these factors can damage or shorten the pump life.

Always select pumps on the ascending side of the efficiency curve close to BEP.

3. Run out point (maximum flow point): This is the point where the pump curve almost touches the horizontal axis. This would be where the pump produces its maximum flow rate, but in theory would add zero head to the fluid. No real piping systems will allow a pump to operate at the run out point of the pump curve. To do so would require a piping system with zero flow resistance and that just isn't possible. The pump will be noisy and vibrate excessively at this point. The pump will consume the maximum amount of power at this point.

The pump curves of circulators stop before they intersect the horizontal axis of the graph. In such cases, the circulator should not be operated at flow rates greater than that corresponding to the right end of the pump curve.

Note that the pump curve is furnished by the pump manufacturer.

Developing a System Curve

A pump does not create pressure; it only provides flow against a resistance imposed by system piping. Every segment of pipe, every fitting, every valve or other component in a piping loop causes resistance to flow due to friction. Friction always causes energy to be dissipated. In this case, that energy is the head (pressure) the pump adds to the fluid. This is why it's appropriate to say that a piping component or loop creates "head loss."

The amount of head loss depends on several things: these include pipe size, pipe type (e.g. plastic pipe versus black iron), the density and viscosity of the fluid being pumped, and the shape of the flow passage through the component(s). The sum of the head losses of all components determines the total head loss of that loop.

The head loss varies as square of flow rate and is represented as "system curve". Being square relation, the shape of the curve is parabolic.

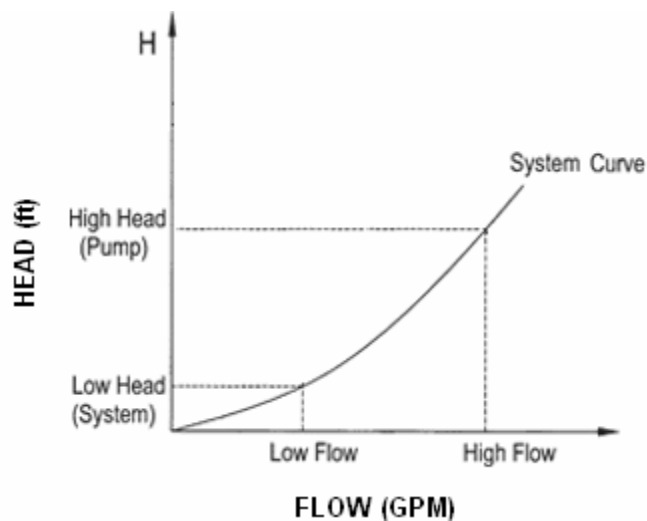

The pump suppliers try to match the system curve supplied by the user with a pump curve that satisfies these needs as closely as possible. To find the operating point at which a particular piping system and pump will settle, you need to plot a "system head loss curve" on the same graph as the pump curve. Where these curves cross is the operating point. The flow rate at this point is found by drawing a vertical line from the operating point down to the horizontal axis and reading the value of flow rate.

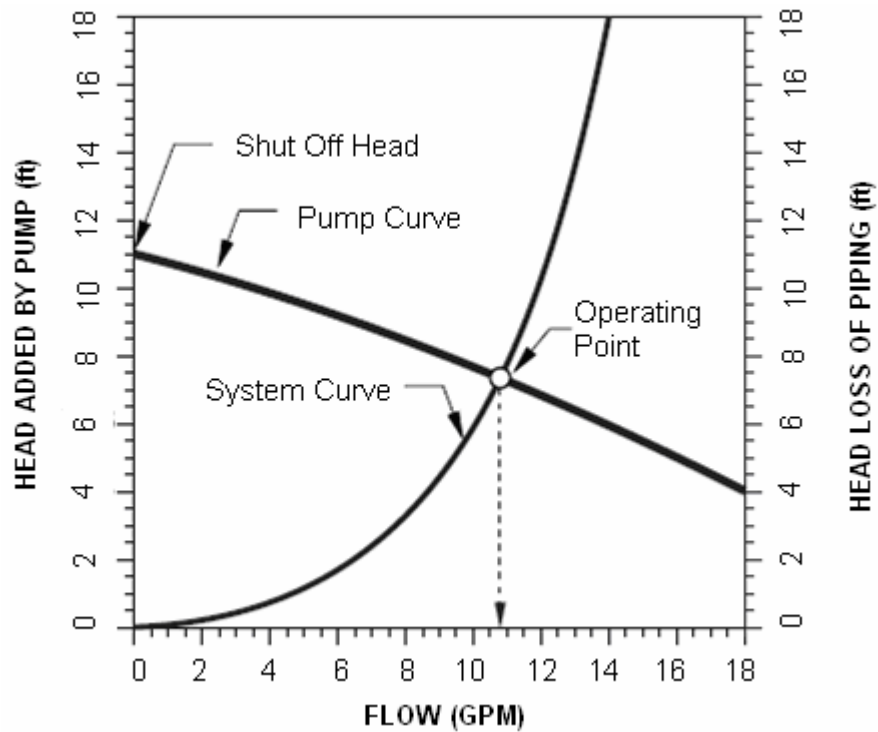

Only at this operating condition is there perfect balance between head input from the pump and head loss from the piping system. When the pump is turned on, the flow rate in the piping loop increases until this balance point is reached, and remains at this flow rate: this usually only takes a few seconds.

If something happens that changes the head loss characteristic of the piping loop (such as a valve adjustment), the balance point slides up or down the pump curve to reestablish the balance between head energy input and head loss.

Likewise, if something happens that changes the pump curve of the pump (such as a speed change of the motor), the balance point also slides up or down the pump curve until a new balanced condition is established.

Note that while the pump curve is generated by the supplier, the system curve is developed by the user based upon the conditions of service. It is for the user to evaluate system conditions and select the optimum pump type and configuration based on efficiency and pump characteristics.

The pump curve also shows its best efficiency point (BEP), required input power (in BHP), NPSHr, speed (in RPM), and other information such as pump size and type,

impeller size, etc. This curve is plotted for a constant speed (rpm) and a given impeller diameter (or series of diameters) and are based on a specific gravity of 1.0.

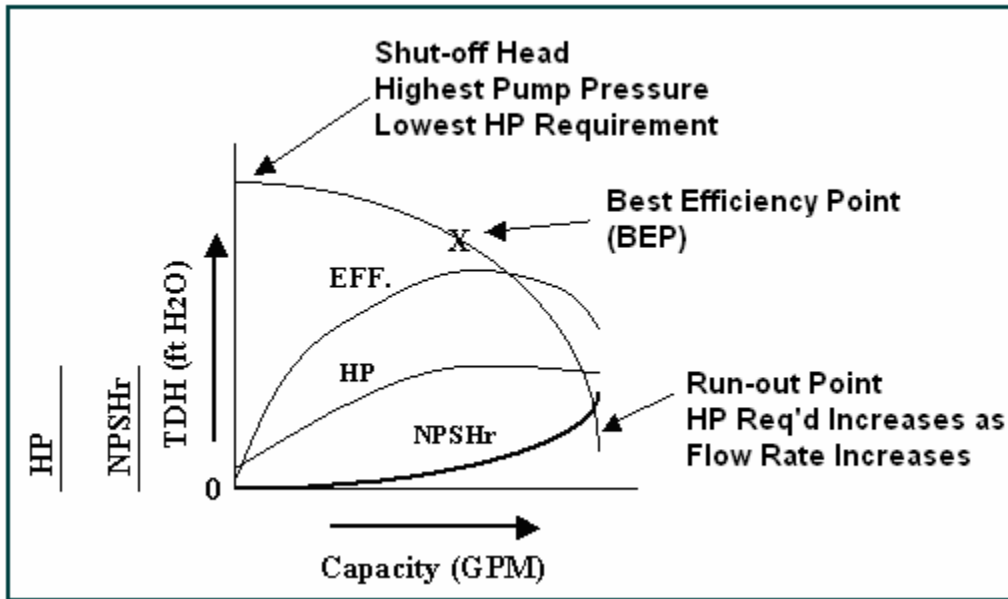

The discussion above illustrates typical pump curve for a fixed speed and fixed impeller size. The centrifugal pump performance can also be represented by multiple curves with a variety of impeller sizes or same size impeller at varying speed.

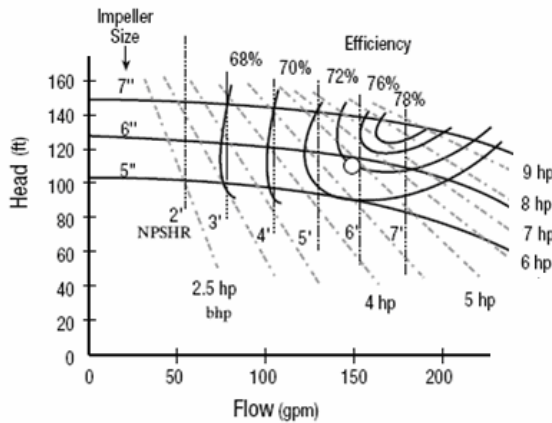

Figure - a

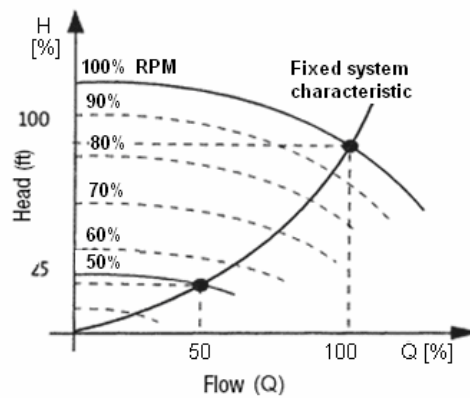

Figure - b

Figure – ‘a’ shows performance curves for different sizes of impellers. To minimize pumping system energy consumption, select a pump so the system curve intersects the pump curve within 20% of its BEP.

Figure- ‘b’ shows performance curves for an impeller made to operate at different speeds. This is most energy efficient for varying flow demands.

Shape of Pump Curve

Different pumps, although designed for similar head and capacity can vary widely in the shape of their Characteristic Curves. For instance, if two pumps are designed for 200 GPM at 100' TDH, one may develop a shut off head of 110' while the other may develop a shut off head of 135'. The first pump is said to have a flat curve while the second is said to have a steep curve. The steepness of the curve is judged by the ratio of the head at shut off to that at the best efficiency point. Each type of curve has certain applications for which it is best suited.

Broadly there are three types of H-Q curves: Steep, Flat and Drooping. Steep curves are characterized by a large change in total head between shut off and capacity at maximum efficiency, while a small change occurs for flat curves.

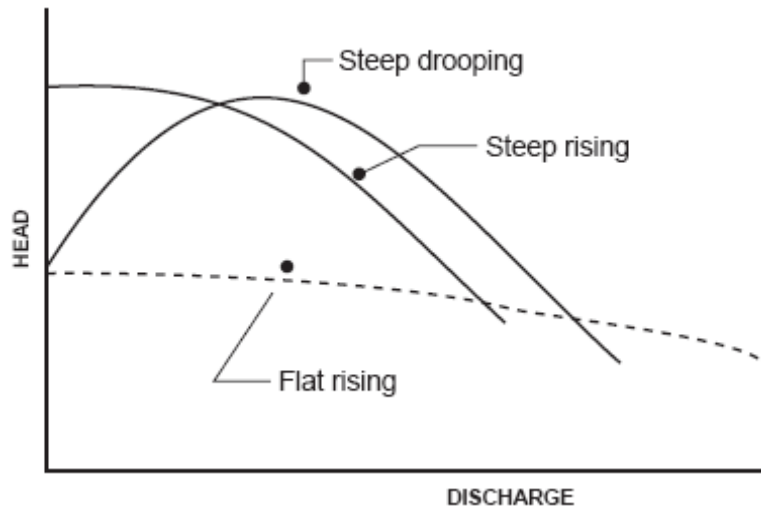

A flat curve is sometimes desirable since a change in flow only causes a small change in head, for example as in a sprinkler system. As more sprinklers are turned on, the head will tend to decrease but because the curve is flat the head will decrease only a small

amount which means that the pressure at the sprinkler will drop only a small amount, thereby keeping the water velocity high at the sprinkler outlet. The National Fire Prevention Association (N.F.P.A.) code stipulates that the characteristic curve must be flat within a certain percentage.

Drooping curves are characterized by an increase in total head to some maximum value as capacity increases, then a decrease as capacity continues to increase; maximum head does not occur at shutoff. The drooping curve shape is to be avoided because it is possible for the pump to hunt between two operating points which both satisfy the head requirement of the system. This is known to happen when two pumps are in parallel, when the second pump is started it may fail to get to the operating point or hunt between two points that are at equal head.

Steep and flat curves are called stable curves because only one capacity exists for a particular head. Drooping curves are called unstable curves, as two operating capacities for given head are possible on either side of the maximum head point. The instability created by the existence of two possible discharge rates at the same head can cause a system to hunt back and forth between capacities. Performance curves also may have irregularities or flat regions which can cause unstable performance if the pump operates within the unstable region.

Pump Specific Speed

Pump speed is usually an important consideration in system design. The pump speed is perhaps best determined by evaluating the effectiveness of similar pumps in other applications. In the absence of such experience, pump speed can be estimated by using a dimensionless pump performance parameter known as specific speed.

Specific Speed is often confusing to many of us because when we see the word speed, we immediately think “impeller speed”. Actually, it is just a number that refers to a particular impeller design or geometry without respect to its size (capacity). It uses the knowledge we have gained over the years to categorize the performance of various impeller designs based upon our application requirements. The chart below shows the relationship of the numerical value of specific speed to a particular impeller design.

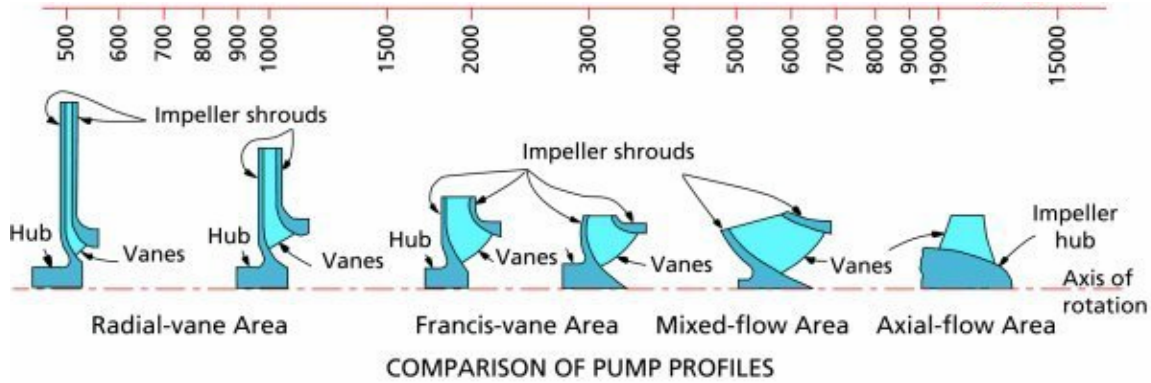

The lower values (500 to 1000) on the left describe the changing geometry of the radial vane impeller while the higher values (10000 – 15000) on the right equate to true axial flow impellers. Those in the middle (1500 – 7000) are typical of the Francis vane and mixed flow (which show both radial and axial characteristics) impellers. The cross sectional pictures on the chart show that, as specific speed increases, the impeller inlet or eye diameter increases and eventually approaches or equals that of the vane outlet. The flow passages also increase in size at a corresponding rate.

Specific speed can be used in two different references: impeller specific speed and pump suction specific speed. The impeller specific speed (N_s) is used to evaluate a pump’s performance using different impeller sizes and pump speeds. N_s is an index that, in mechanical terms, represents the impeller speed necessary to generate 1 gallon per minute at 1 foot of head. The equation for impeller specific speed is as follows:

$$N_s = \frac{n \sqrt{Q}}{H^{3/4}}$$

Where

- N_s = specific speed
- n = pump rotational speed (rpm)
- Q = flow rate (GPM)
- H = total head per stage (ft).

The N_s of a given pump is the same at all rotative speeds. A low specific speed indicates a pump designed for a low capacity and a high pumping head. Conversely, a high N_s pump is one designed for a high capacity and a low pumping head.

Suppose, for example, we need an impeller that will produce 1000 GPM at 200 feet of head. If we enter these values in Q and H and also enter a motor speed of 3600 rpm we obtain a specific speed of 2140. The impeller would have geometry similar to the Francis vane impeller seen on the chart at the 2000 point. An 1800 rpm motor would lower the specific speed to 1070 and would have geometry similar to the radial vane impeller. At 1200 rpm specific speed is 714 and the impeller would look like a hybrid of the two impellers seen to the left of the char.

As a rule of thumb, impeller efficiency reaches its maximum at a specific speed between 2000 and 3000. Also the area around the Best Efficiency Point (BEP), or design point, tends to be flatter and broader as specific speed decreases. (Impeller efficiency also increases with pump rotational speed, especially high speeds, but that increase is not as pronounced at speeds of 3600 rpm and below.) Specific speed also affects the shape of the head-capacity curve. Low specific speeds (500 – 2000) produce relatively flat curves while high speeds (5000 +) produce extremely steep curves. Intermediate speeds produce curves that fall in between these extremes. These results are due to the vane shape (flat versus backwards curved) at various specific speeds. Finally, specific speed provides us with one more prediction - the characteristics of the power curve. At specific speeds below 3500, power drops as flow is reduced and is at its minimum at shut off head. The power curve remains relatively flat, across the entire head-capacity curve, between 4000 and 4500 and rises towards shut off at specific speeds above 5000. At speeds above 9000 the power and head-capacity curves almost parallel one another. Stated differently, power is greatest at shut off and is at its minimum at full flow.

Once a particular impeller geometry is chosen, the pump designer can go through a comprehensive mathematical analysis that will allow him to derive all of the impeller dimensions and angles necessary to meet the design point.

Suction Specific Speed (S)

Suction specific speed, like impeller specific speed, is a parameter for indexing hydraulic design used to describe the suction capabilities and characteristics of a pump impeller. Suction specific speed (S) can be expressed mathematically as follows:

$$S = N Q / (\text{NPSHR})^{0.75}$$

Where

- N = speed (rpm) @ full load (single stage)
- Q = flow (GPM) @ BEP
- NPSHR = Net Positive Suction Head Required (ft.) @ BEP

S is a number used for labeling impellers relative to their NPSH requirement. It is independent of the pump size and impeller (operating) specific speed (Ns). S is primarily an impeller design parameter and is not an important factor in the application of low capacity (< 3000 GPM) submersible pumps, and is discussed for completeness.

Suction specific speeds (S) can range from 3000 - 20,000, depending on the impeller design, speed, capacity and condition of service. Good quality commercial pump designs fall into the (S) range of 7,000 - 10,000.

Cavitation

Centrifugal pumps are susceptible to a damaging and performance-degrading effect known as cavitation. Cavitation occurs when there is insufficient NPSH Available i.e. when static pressure in the pump drops below the vapor pressure of a fluid. The liquid vaporizes in the form of tiny bubbles; then, when the surrounding pressure increases, the fluid returns to liquid as these tiny bubbles collapse violently. The collapse of the bubbles sends high-velocity water jets into surrounding surfaces, which can damage the impeller and erode the pump casing and piping surfaces. When a pump experiences cavitation, the result is accelerated bearing and seal wear and poor system performance.

Cavitation usually occurs at high flow rates, when a pump is operating at the far right portion of its performance curve. However, cavitation-like damage can also occur at low flow rates, when damaging vortices develop in the pump. Cavitation is indicated by

crackling and popping noises, similar to the sound of marbles flowing through a pipe. If uncorrected, cavitation can lead to expensive repairs.

Net Positive Suction Head (NPSH)

To prevent cavitation, centrifugal pumps must operate with a certain amount of pressure at the inlet. This pressure is defined as the net positive suction head (NPSH). There are two principal references to NPSH: (1) the available system pressure (NPSHA) at the inlet, which is a function of the system and the flow rate, and (2) the required pressure (NPSHR), which is a function of the pump and the flow rate.

Net Positive Suction Head Required (NPSHR) is a function of a specific pump design. In simple terms it is the pressure, measured at the centerline of the pump suction, necessary for the pump to function satisfactorily at a given flow. Although NPSHR varies with flow, temperature and altitude have no effect.

Net Positive Suction Head Available (NPSHA) is a characteristic of the system in which the pump operates. It depends upon the elevation or pressure of the suction supply, friction in the suction line, elevation of the installation, and the vapor pressure of the liquid being pumped.

If the NPSHA is sufficiently above the NPSHR, then the pump will NOT cavitate.

Both available and required NPSH vary with the capacity of a given pump and suction system. NPSHA is decreased as the capacity is increased due to the increased friction losses in the suction piping. NPSHR increases approximately as the square of capacity since it is a function of the velocities and friction in the pump inlet. NPSHA can be calculated as follows:

$$\text{NPSHA} = H_a + H_s - H_{vp}$$

Where:

- H_a = Atmospheric pressure in feet
- H_s = Total suction head or lift in feet
- H_{vp} = Vapor pressure in feet

A pumping application located at an elevation of 5000 feet will experience a reduction in atmospheric pressure of approximately six feet. This will result in a reduction in NPSHA by the same amount. Elevation must be factored into a pumping application if the installation is more than a few hundred feet above sea level.

Often a two foot safety margin is subtracted from NPSHA to cover unforeseen circumstances. A common rule in system design is to ensure that NPSHA is 25% higher than NPSHR for all expected flow rates. When oversized pumps operate in regions far to the right of their design points, the difference between NPSHA and NPSHR can become dangerously small.

The pump net positive suction head (NPSH) has extremely limited usage for closed systems (chilled water circulation loops). Most closed air-conditioning system pump application does not require NPSH evaluation because it is possible to obtain adequate pump suction pressurization.

Affinity Laws

The Affinity Laws tell us quite a bit about the inner workings of an impeller. When the driven speed or impeller diameter of a centrifugal pump changes, the operation of the pump changes in accordance with three fundamental affinity laws:

1. Capacity varies directly as the change in speed
2. Head varies as the square of the change in speed
3. Brake horsepower varies as the cube of the change in speed
4. Capacity varies as the cube of the change in diameter of impeller
5. Head varies as the square of the change in diameter of impeller
6. Brake horsepower varies as the fifth power of the change in diameter of impeller

The relationships between these variables can be expressed mathematically as below:

$$\frac{Q_1}{Q_2} = \frac{n_1 D_1^3}{n_2 D_2^3} \quad \frac{H_1}{H_2} = \frac{n_1^2 D_1^2}{n_2^2 D_2^2} \quad \frac{P_1}{P_2} = \frac{n_1^3 D_1^5}{n_2^3 D_2^5}$$

Where subscripts 1 and 2 denote the value before and after the change; P is the power, n the speed, D the impeller diameter, H the total head.

If the speed is fixed they become:

$$\frac{Q_1}{Q_2} = \frac{D_1^3}{D_2^3} \quad \frac{H_1}{H_2} = \frac{D_1^2}{D_2^2} \quad \frac{P_1}{P_2} = \frac{D_1^5}{D_2^5}$$

If the diameter is fixed they become:

$$\frac{Q_1}{Q_2} = \frac{n_1}{n_2} \quad \frac{H_1}{H_2} = \frac{n_1^2}{n_2^2} \quad \frac{P_1}{P_2} = \frac{n_1^3}{n_2^3}$$

If, for example, the pump speed were doubled: Capacity will double, Head will increase by a factor of 4 (2 to the second power) and the Brake horsepower will increase by a factor of 8 (2 to the third power).

These principles apply regardless of the direction (up or down) of the speed or change in diameter. Consider a following example.

A pump operating at 1750 RPM, delivers 210 GPM at 75' TDH, and requires 5.2 brake horsepower. What will happen if the speed is increased to 2000 RPM?

Solution

Speed Ratio = 2000/1750 = 1.14

From the laws of Affinity:

Capacity varies directly or: 1.14 X 210 GPM = 240 GPM

Head varies as the square or: 1.14 X 1.14 X 75 = 97.5' TDH

BHP varies as the cube or: $1.14 \times 1.14 \times 1.14 \times 5.2 = 7.72$ BHP

Whether it is a speed change or change in impeller diameter, the Laws of Affinity are not strictly accurate because of nonlinearities in flow and due to hydraulic efficiency changes that result from the modification. The Laws of Affinity give reasonably close results when the changes are not more than 50% of the original speed or 15% of the original diameter.

SECTION - 4 FLOW CONTROL IN CENTRIFUGAL PUMPS

There are three primary methods for controlling flow in HVAC systems: throttle valves, pump speed control, and multiple pump arrangements. The appropriate flow control method or the combination depends on the system size and layout, fluid properties, the shape of the pump power curve, the system load, and the system's sensitivity to flow rate changes.

Method 1: Valve Control

Using valves to control the flow is the most common and cheapest way. A throttle valve chokes fluid flow so that less fluid can move through the valve, creating a pressure drop across it. Increasing the upstream backpressure reduces pump flow; but makes the pumping system less efficient.

Commonly used valves are butterfly valve, gate valve and ball valve etc. However these are not recommended for flow control. We recommended the globe type or needle type valve design for flow control.

Effect of valves control is to modify system characteristic and induce the artificial loss.

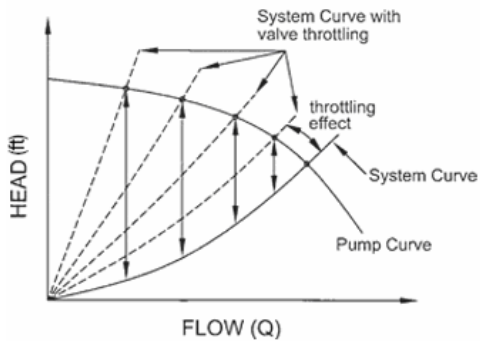

Figure - a

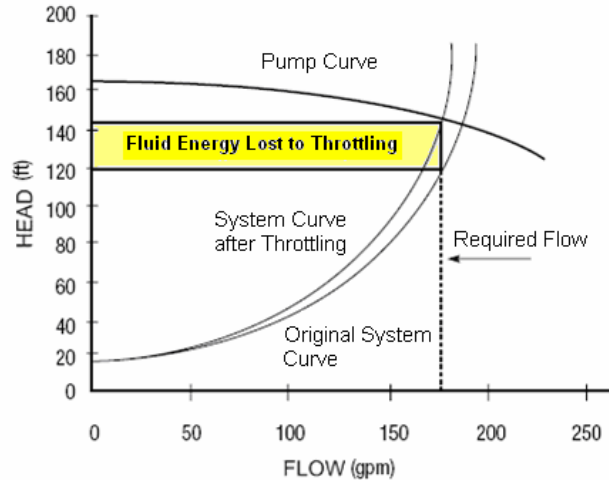

Figure - b

Figure – a shows the head loss during throttling and,

Figure – b shows fluid power lost across a throttling valve.

Method 2: Pump Speed Adjustments

Conventional chilled water plants distribute water at constant flow rate, regardless of the actual cooling demand. Since most air-conditioning systems only reach peak load a few hours a year, energy is wasted by continually running the pumps at constant flow (speed). An efficient distribution system use variable flow that tracks the variable thermal load.

Pumps that experience highly variable demand conditions are often good candidates for adjustable speed drives (ASDs). The most popular type of ASD is the variable frequency drive (VFD). VFDs use electronic controls to regulate motor speed, which, in turn, adjusts the pump’s output. The principal advantage of VFDs is better matching between the fluid energy that the system requires and the energy that the pump delivers to the system. As system demand changes, the VFD adjusts the pump speed to meet this demand, reducing the energy lost to throttling or bypassing excess flow. The resulting energy and maintenance cost savings often justify the investment in the VFD.

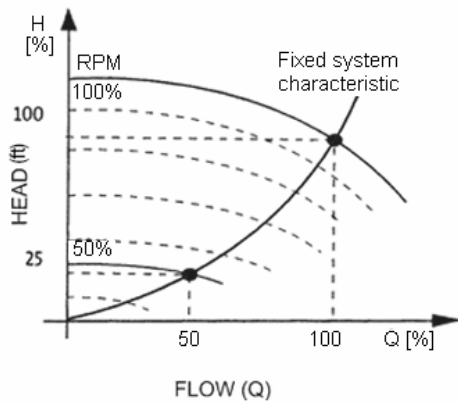

Figure - a

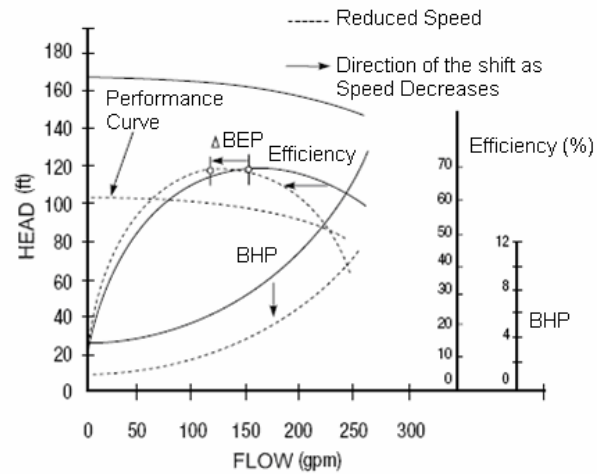

Figure - b

The effect of slowing pump speed on pump operation is illustrated by the dashed curves in figure above.

Figure – a, shows that at lower speed, the pump curve drifts lower but the system curve remains the same.

Figure- b shows the effects of reducing speed on pump’s operating characteristics - at slow speed the pump’s head/flow and brake horsepower (BHP) curves drop down to the left and its efficiency curve shifts to the left.

Advantages of Variable Frequency Drives (VFDs)

The major benefit of VFDs is that they can reduce energy losses by lowering the overall system flow or head. Refer to the affinity laws which states that power varies as cube of flow rate. If the flow rate were half the higher flow rate then the power necessary to provide the slower flow rate would be $(0.5)^3 = 0.125$ or 12.5 % of the power required for the higher flow rate. It means an energy saving of 87.5 %.

VFDs provide a soft-start capability. During start-up, most motors experience in-rush currents that are 5 to 6 times higher than normal operating currents. This high current fades when the motor achieves normal speed. VFDs allow the motor to be started with a lower start-up current—usually only about 1.5 times the normal operating current. This reduces wear on the motor and its controller.

VFDs lower the maintenance requirements for the pump, system piping, and components. By reducing a pump's operating speed, a VFD often shifts the BEP to the left of the BEP corresponding to the pump's normal operating speed. In these cases, since the bearing loads on a pump are lowest when the pump is operating at its BEP, this shift of the BEP during periods of low flow allows the pump to operate with lower bearing loads and less shaft deflection. Most pump bearings are roller or ball-type; their design operating life is a function of the cube of the load. Consequently, using a VFD can extend the interval between bearing maintenance tasks.

VFDs reduce stress on pipes and piping supports. When the system flow far exceeds equipment demands, excess fluid energy is dissipated in the form of noise and vibration. Vibrations help to loosen mechanical joints and cause cracks in the welds in pipes and pipe hangers. By reducing the fluid energy, VFDs lessen system wear.

Limitations of VFDs

VFDs are not practical for all applications—for example, systems that operate high static head and those that operate for extended periods under low-flow conditions. In HVAC chilled water applications, the static head is zero (being a closed system), therefore VFD is ideal for chilled water distribution. For cooling tower application, however, the static head needs to be taken into account.

Power quality can also be a concern. VFDs operate by rectifying the alternating current (ac) line power into a direct current (dc) signal, then inverting and regulating this signal into ac power that is sent to the motor. Often, the inverter creates harmonics in the power supplied to the motor. These harmonics can cause motor windings to operate at higher temperatures, which accelerate wear in insulation. To account for the added winding heat, motors are typically derated 5% to 10% when used with VFDs. A classification of motors known as “inverter-duty” has been developed to better match VFDs with motors.

In some electrical systems, the harmonics created by the inverter can be picked up by other electrical lines that have common connections with the VFD. Systems that are sensitive to minor disturbances in power supply should be served separately from the VFD power supply.

Method 3: Multiple Pump Arrangements

Parallel Operation

When the pumped flow requirements are widely variable, it is often desirable to install several small pumps in parallel rather than use a single large one. When the demand drops, one or more smaller pumps may be shut down, thus allowing the remainder to operate at or near peak efficiency. Some of the advantages of multiple pump arrangements are flexibility, redundancy, and the ability to meet changing flow needs efficiently in systems with high static head components.

Multiple pumps are usually parallel combinations of the usually identical pumps (same pump model), to provide balanced load-sharing when all the pumps are operating at the same time. Because the pumps are the same size they can operate together, serving the same discharge header. If the pumps were different sizes, the larger pumps would tend to dominate the smaller pumps and could cause them to be inefficient. If different-sized pumps must be configured in parallel, their performance curves should be carefully reviewed to ensure that no pump operates below its minimum flow requirement.

Placing an additional pump on line adds flow to the system and shifts the operating point to the right along the system curve.

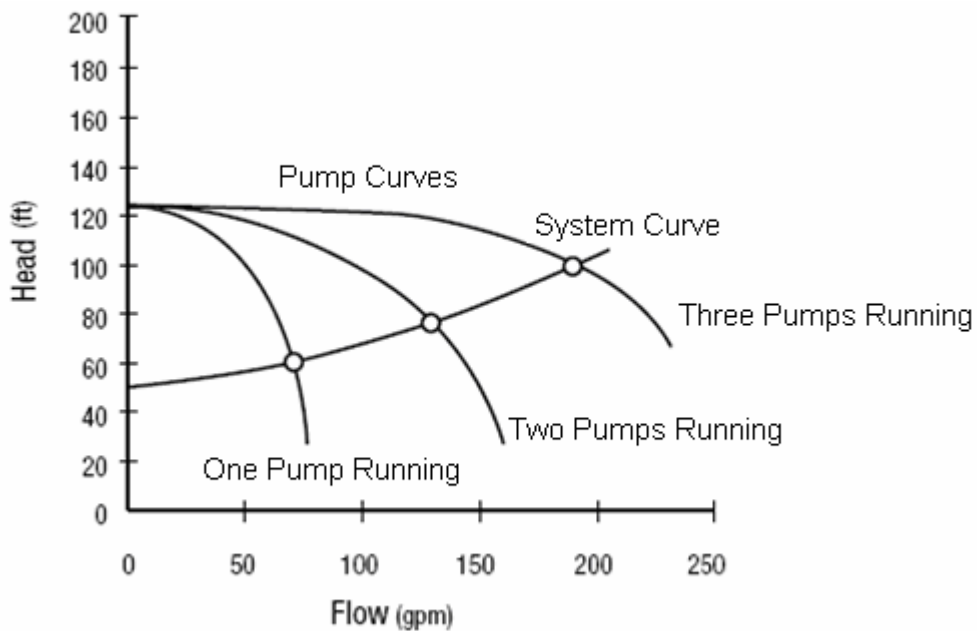

Multiple Pump Operation

Advantages of Multiple Pumps in Parallel Arrangements

Multiple pumps in parallel are well suited for systems with high static head. There are many advantages to using combinations of smaller pumps rather than a single large one. These advantages include operating flexibility, redundancy in case of a pump failure, lower maintenance requirements, and higher efficiency.

Operating Flexibility - As shown in performance curves, using several pumps in parallel broadens the range of flow that can be delivered to the system. In addition, energizing and de-energizing pumps keeps the operating point of each one closer to its BEP (for systems with flat curves). Operators should use caution when operating parallel pumps, however, to ensure that the minimum flow requirement is met for each pump.

Redundancy - With a multiple pump arrangement, one pump can be repaired while others continue to serve the system. Thus, the failure of one unit does not shut down the entire system.

Maintenance - Multiple pump configurations allow each pump to be operated close to its BEP (for systems with flat curves), which reduces bearing wear and permits the pumps to run more smoothly. Other benefits include less reliance on energy-dissipating flow control options such as bypass lines and throttle valves. The use of a single, large pump during low-flow demand conditions forces the excess flow to be throttled or bypassed. Throttling the flow wears the throttle valves and creates energy losses. Similarly, bypassing the flow is highly inefficient; since all the energy used to push the excess flow through the bypass lines is wasted. Variable speed drives can also be an efficient solution.

Efficiency - A potential advantage of using multiple pumps is higher overall efficiency, since each pump can operate close to its BEP (for systems with flat curves). Energizing or de-energizing pumps as needed to meet changes in system demand allows each pump to operate over a smaller region of its performance curve—ideally, around the BEP. A single pump would have to operate over a larger range, and thus farther away from its BEP at times. At a given head and flow, high-speed pumps tend to be more efficient than low-speed pumps. Pumps with specific speed values greater than 3,000

are the exception; they tend to be less efficient at higher speeds. However, this is not typical of most pumps. Since smaller pumps require smaller motors, the use of multiple high speed pumps can provide an efficiency advantage over a single, low-speed pump. However, this efficiency advantage should be balanced against the tendency of high-speed machines to require more maintenance.

Series Operation (Booster Service)

When a centrifugal pump is operated with a positive suction pressure, the resulting discharge pressure will be the sum of the suction pressure and the pressure normally developed by the pump when operating at zero suction pressure. It is this quality of a centrifugal pump that makes it ideally suited for use as a booster pump. This quality also makes it practical to build multi-stage (multiple impellers) pumps. A booster pump takes existing pressure, whether it is from an elevated tank or the discharge of another pump, and boosts it to some higher pressure.

Two or more pumps can be used in series to achieve the same effect. To connect two pumps in series means that the discharge from the first pump is piped into the inlet side of the second pump. Multiple pumps in series may be used when liquid must be delivered at high pressure. Series operation is most commonly required when:

1. The system head requirements can not be met at the required capacity with a single unit
2. A system with adequate capacity has been expanded beyond the original pressure design constraints, requiring a boost in pressure to circulate water to their old and new piping at the desired flow rate for optimum heat transfer.

Use Smaller Pumps to Augment Larger Pumps – Pony Pump

Pumps that maintain fluid levels in tanks or reservoirs are often sized according to worst-case or peak service conditions. Since the requirements of worst-case conditions are often significantly higher than those of normal operating conditions, many pumps are oversized relative to the demands of their application for most of their operating lives. The penalties of using an oversized pump include frequent energizing and de-energizing of the motor, operation away from the pump's BEP, and high friction losses—all of which add to energy and maintenance costs.

Adding a smaller pump (also referred as pony pump) to handle normal system demand relieves the burden on the larger pump, which can be energized as needed during high load conditions. A smaller pump can operate more efficiently and require less maintenance.

When to Consider Pony Pumps

Indicators of a need for a smaller pump to handle normal operating conditions include the following:

1. Intermittent pump operation
2. Excessive flow noise, cavitation, and piping vibrations that disappear during heavy demand periods. (If these conditions persist, then the primary pump may need to be downsized.)

In applications such as sewage treatment plants, the normal operating demands on pumps may be relatively low. During storms, however, the amount of fluid that must be drained from holding ponds or tanks increases dramatically. So pumps that maintain holding pond levels must be able to handle storm conditions. To avoid the high friction losses and maintenance problems that accompany continuous operation or frequent starts of oversized pumps, a plant can install smaller ones, called “pony pumps,” to handle normal operating conditions. The large pumps would then be used occasionally only to handle severe load conditions, providing considerable cost savings.

Impeller Trimming

Impeller trimming refers to the process of machining the diameter of an impeller to reduce the energy added to the system fluid. Impeller trimming can be a useful correction to pumps that, through overly conservative design practices or changes in system loads, are oversized for their application.

Impeller trimming reduces tip speed, which in turn directly reduces the amount of energy imparted to the system fluid and lowers both the flow and pressure generated by the pump. The affinity laws describe fundamental effect of impeller trimming on flow, head, and BHP: for example, a 2% reduction in the impeller diameter creates about a 2% reduction in flow, a 4% reduction in head, and an 8% reduction in power. This

relationship should be used as an approximation for small changes. The final result of trimming depends on the system curve and pump performance changes.

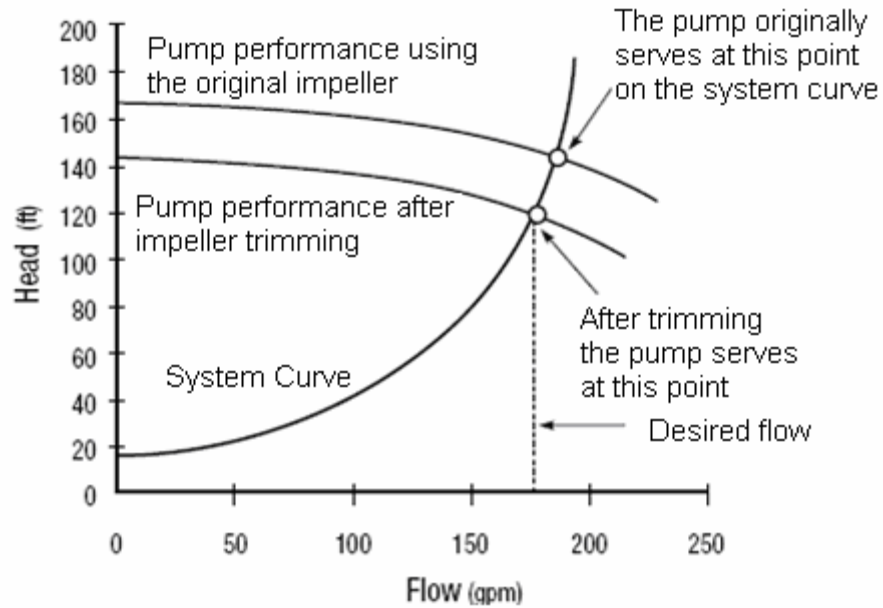

Effect of Impeller Trimming on Pump Performance

Limitations

Trimming an impeller changes its operating efficiency, and the nonlinearities of the affinity laws with respect to impeller machining complicate predictions of a pump's performance. Consequently, impeller diameters are rarely reduced below 70% of their original size.

In some pumps, impeller trimming increases the pump's required net positive suction head (NPSHR). To prevent cavitation, a centrifugal pump must operate with a certain amount of pressure at its inlet, the NPSHR. To reduce the risk of cavitation, the effect of impeller trimming on NPSHR should be evaluated using the manufacturer's data over the full range of operating conditions.

Minimum Continuous Flow

All centrifugal pumps have limitations on the minimum flow at which they should be operated. Minimum flow problems typically develop as a result of excessive throttling and or improper sizing. Internal recirculation tends to occur at low flow rates when fluid

leaving the impeller forms damaging vortices. This damages pump in much the same way that cavitation does. To avoid this problem, manufacturers list the minimum flow rates for their pumps. Operators should be aware of this minimum flow requirement and avoid overly restricting pump output. *Small by-pass lines are sometimes installed to prevent the pump from running at zero flow.*

There are three factors which must be looked at with respect to minimum flow. These are:

1. **Mechanical ability** - this is the ability of the pump to withstand all of the forces (side thrust, axial thrust, vibration, etc.) associated with operating the pump at low flows.
2. **Hydraulic stability** - this is the stability of the pump to operate at flow rates other than the Best Efficiency Point (or nearby), particularly low flow rates as a percentage of the BEP, without detrimental internal recirculation, hydraulic instabilities, etc. that can cause pump damage.
3. **Thermal stability** - has to do with the properties of the particular liquid being pumped and the effects of heat (temperature) rise to liquid. See HEAT INPUT above for a discussion of temperature rise. A commonly accepted conservative temperature rise through a pump is 15°F. For a 15°F rise, the minimum flow can be calculated as follows:

$$Q_{min} = BHP / (2.95 * C_p * S.G)$$

- Q_{min} = Minimum flow rate for 15°F temperature rise in GPM
- BHP = Power input at the minimum flow
- 2.95 = constant for 15°F temperature rise. Use 3.93, 1.96 and 1.0 for 20°F, 10°F and 5°F temperature rise respectively
- S.G = Specific gravity

It is important to understand that a catastrophic failure of any pump can occur if the liquid within the pump casing is allowed to vaporize. To prevent flashing, a flow must be maintained through the pump which will keep the liquid below its saturation temperature.

Shut-off Operation (Closed Discharge Valve)

Shut-off operation of centrifugal pumps is often necessary to prevent water hammer at start-up and or shut down in fixed speed applications. Short duration operation at shut-off (minutes) is normally permissible for pumps with low to medium specific speed impellers ($N_s = 3500$ or less).

Prolonged operation at shut-off head will result in rapid failure of pumping equipment. The failure mode is the same as those cited for minimum flow, but accelerated.

Many small circulator pumps have no formal minimum flow or shut off limitations except for temperature build-up considerations.

SECTION – 5 HEAD & CAPACITY RELATIONSHIPS

Total dynamic head (TDH) is very important in specifying the pump sizes. The required pump head can be calculated by applying Bernoulli's equation. Bernoulli's relationship applies to any pumping system but the typical hydronic system, as chilled water loop, is a special case. As water re-circulates, picking up heat at one heat exchanger (AHU or fan-coil) and dropping it off at the other (chiller's evaporator), points a and b could be defined at the same point. In closed systems the first three terms of the Bernoulli equation equals zero. Solely the friction of the system determines pump head.

Bernoulli's relationship:

$$H = \left[\frac{P_b - P_a}{\gamma} \right] + [Z_b - Z_a] + \left[\frac{V_b^2 - V_a^2}{2g} \right] + h_{friction}$$

Where:

- H: Pump head required to move water from the point a to point b in the system (ft)
- P: Pressure at points a or b (lb/ft²)

- Gamma : Liquid density (water density = 62.4 lb/ ft³)
- Z: Elevation of the liquid surface at a or b from any constant reference level (ft)
- V: Velocity at a or b (ft/sec)
- g: Gravitational constant (32.2 ft/sec²)
- h_{friction} : Friction loss in the pipes, heat exchangers, coils and fittings in ft-lb of work per pound of liquid required to overcome friction (ft)

The TDH involves several different things:

- Static head - The vertical distance the water is being pumped to the point of use.
- Terminal pressure - The operating pressure desired at the point of use.
- Friction Loss - The friction losses from water moving through the piping system.

The static head and the terminal pressure are fixed by process use and the variable friction loss in a hydraulic system comes from the head losses in components such as evaporator heat exchanger, cooling coils and control valves. Equipment manufacturers provide these component head losses measured in feet of head loss or pounds per square inch difference (psid) at some specific flow rate. Other sources of friction loss in a hydraulic system are pipes and fittings that can represent a significant amount of friction loss in large systems. The total friction loss of all these components, calculated at the design flow rate, determines the pump head required.

The Darcy-Weisbach equation is a commonly used empirical expression for friction head loss in piping:

$$h = f \left(\frac{L}{D} \right) \left(\frac{v^2}{2g} \right)$$

Where

- h = head loss due to friction (ft)
- f = pipe friction coefficient

- V = fluid velocity (ft/sec)
- g = gravitational constant (ft/sec²)
- D = inner diameter of the pipe (ft)
- L = length of pipe (ft)

Some important conclusions arise from the Darcy-Weisbach relationship:

The four factors that determine friction losses in pipe are:

1. The velocity of the water: The head loss for fluid flow varies the square of the fluid velocity. As velocity increases, pressure losses increase. Velocity is directly related to flow rate. An increase or decrease in flow rate will result in a corresponding increase or decrease in velocity. For example, for a given size pipe, a flow rate that is two times higher endures four times more friction loss. This means that it costs much more to pump a gallon of fluid at a higher than- necessary flow rate. At velocities greater than 5 feet per second, the friction losses become prohibitive.
2. The size (inside diameter) of the pipe: Smaller pipe causes a greater proportion of the water to be in contact with the pipe, which creates friction. Pipe size also affects velocity. Installing larger diameter pipe results in reduction in fluid velocity and therefore results in lower friction losses.
3. The roughness of the inside of the pipe: Pipe inside wall roughness is rated by a “ f ” factor. The higher the “ f ” value, the rougher the inside and more the pressure loss due to friction.
4. The length of the pipe: The greater the distance, the greater the friction losses will be.

A wider analysis of the Darcy Weisbach equation leads to state that system head loss is a squared function of system flow:

Head-flow relationship:

$$\frac{h_1}{h_2} = \left[\frac{Q_1}{Q_2} \right]^2$$

In theory, friction losses which occur as liquid flows through a piping system must be calculated by means of complicated formulae, taking into account such factors as liquid density and viscosity, and pipe inside diameter and material.

This loss can be calculated using hydraulic formulas or can be evaluated using friction loss tables, nomographs, or curves provided by pipe manufacturers. Table below shows a typical pipe friction table for water at 60° F flowing through schedule 40 steel pipes. If the pipe schedule or material is other than schedule 40 steel pipes, a different table or an adjustment to the table must be used. Friction data for other pipe materials and inside diameters are often found in engineering data tables, or are sometimes available from the manufacturers of pipe.

Friction Loss of Water in Feet per 100 Feet of Schedule 40 Steel Pipe

U.S. Gallons per minute	2 In. (2.067" I. D.)			2 1/2 In. (2.469" I. D.)			3 In. (3.068" I. D.)			3 1/2 In. (3.548" I. D.)		
	V	V ² /2g	h _f	V	V ² /2g	h _f	V	V ² /2g	h _f	V	V ² /2g	h _f
30	2.87	0.128	1.82	2.01	0.063	0.75						
35	3.35	0.174	2.42	2.35	0.085	1.00						
40	3.82	0.227	3.10	2.68	0.112	1.28						
50	4.78	0.355	4.67	3.35	0.174	1.94	2.17	0.073	0.66			
60	5.74	0.511	6.59	4.02	0.251	2.72	2.60	0.105	0.92	1.95	0.059	0.45
80	7.65	0.909	11.4	5.36	0.447	4.66	3.47	0.187	1.57	2.60	0.105	0.77
100	9.56	1.42	17.4	6.70	0.698	7.11	4.34	0.293	2.39	3.25	0.164	1.17
120	11.5	2.05	24.7	8.04	1.00	10.0	5.21	0.421	3.37	3.89	0.236	1.64
140	13.4	2.78	33.2	9.38	1.37	13.5	6.08	0.574	4.51	4.54	0.321	2.18
160	15.3	3.64	43.0	10.7	1.79	17.4	6.94	0.749	5.81	5.19	0.419	2.80
180	17.2	4.60	54.1	12.1	2.26	21.9	7.81	0.948	7.28	5.84	0.530	3.50
200	19.1	5.68	66.3	13.4	2.79	26.7	8.68	1.17	8.90	6.49	0.655	4.27
220	21.0	6.88	80.0	14.7	3.38	32.2	9.55	1.42	10.7	7.14	0.792	5.12
240	22.9	8.18	95.0	16.1	4.02	38.1	10.4	1.69	12.6	7.79	0.943	6.04
260	24.9	9.60	111	17.4	4.72	44.5	11.3	1.98	14.7	8.44	1.11	7.04
280	26.8	11.1	128	18.8	5.47	51.3	12.2	2.29	16.9	9.09	1.28	8.11
300	28.7	12.8	146	20.1	6.28	58.5	13.0	2.63	19.2	9.74	1.47	9.26
350				23.5	8.55	79.2	15.2	3.57	26.3	11.3	2.00	12.4
400				26.8	11.2	103	17.4	4.68	33.9	13.0	2.62	16.2
500				33.5	17.4	160	21.7	7.32	52.5	16.2	4.09	25.0
600							26.0	10.5	74.8	19.5	5.89	35.6

700							30.4	14.3	101	22.7	8.02	48.0
800							34.7	18.7	131	26.0	10.5	62.3
1000										32.5	16.4	96.4

Usually velocity (labeled "V" in Table) is used as the criteria for choosing at least a preliminary line size, with the trade-off between piping system cost, pump capital cost, and lifetime energy costs being considered.

Common velocity guidelines are 4 to 6 ft/sec for suction piping and 6 to 10 ft/sec for discharge piping.

With the design capacity and the chosen preliminary pipe size, the friction tables give the head loss in feet per 100 linear feet of pipe (labeled "hf" in Table above). The total friction head loss in a given length of pipe will then be obtained multiplying the value found in Table above by the actual pipe length divided by 100.

Friction head loss in a given length of pipe:

$$H_f = h_f \times \frac{L}{100}$$

Where:

- H_f: Total friction head loss in a given length of pipe (ft)
- L: Actual length of pipe (ft)
- h_f: Head loss per 100 linear feet of pipe (ft)

The friction loss in valves and fittings is determined by the following formula:

$$H_f = K \times \frac{V^2}{2g}$$

Where:

- H_f: Friction head loss in a given valve or fitting (ft)
- K: Resistance coefficient for the particular valve or fitting

- $V^2/2g$: Value found in Table 1 entering with valve/fitting diameters and flow rate

The value of K for the particular valve or fitting is determined using standard charts or the valve manufacturer may have more precise coefficients.

Fitting Losses

Equivalent Length of Pipe in Feet

Pipe Diameter	Valves									
	Gate	Plug	Globe	Angle	Check	Foot				
1.5"	0.9	-	45	23	11	39				
2"	1.10	6.0	58	29	14	47				
3"	1.6	8.0	86	43	20	64				
4"	2.1	17	113	57	26	71				
6"	3.2	65	170	85	39	77				
Pipe Diameter	Elbows		Tube Turn		Tee		Enlrg		Contr	
	45	90	45	90	Strt	Side	1:2	3:4	2:1	4:3
	1.5"	1.9	4.1	1.4	2.3	2.7	8.1	2.6	1.0	1.5
2"	2.4	5.2	1.9	3.0	3.5	10.4	3.2	1.2	1.8	1.2
3"	3.6	7.7	2.9	4.5	5.2	15.5	4.7	1.7	2.8	1.7
4"	4.7	10.2	3.8	6.0	6.8	20.3	6.2	2.3	3.6	2.3
6"	7.1	15.3	5.8	9.0	10.2	31	9.5	3.4	5.6	3.4

Note - To determine the proper pipe size, designers must balance the initial cost of the pipe against the cost of pushing fluid through it. Larger pipes create less friction loss for a given flow rate; however, larger pipes also have higher material and installation costs. Unfortunately, designers often overlook the energy costs of using small piping and focus on the initial cost when sizing system piping.

Example – Head Calculation

In order to illustrate the procedure to be followed in pipe sizing a typical chilled water distribution system and calculating its pressure drop, a three-zone loop serving the coils of their air handling units (AHU) will be used. The system is shown in Figure below:

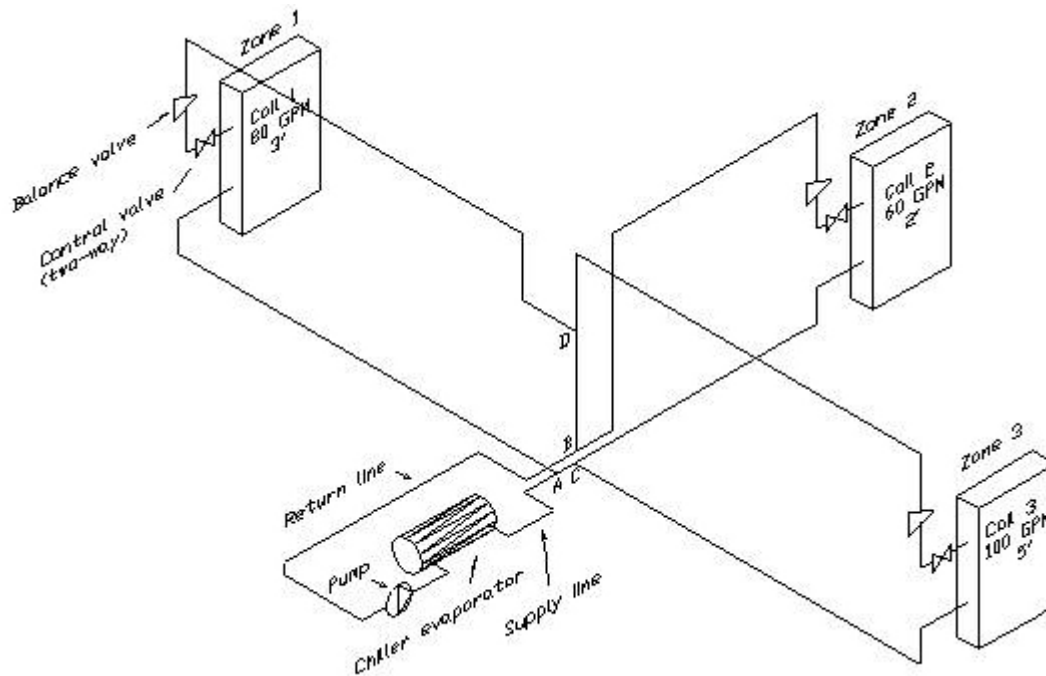

Chilled water distribution system serving a three-zone loop

Chiller Plant Data:

- a. Design thermal load: 120 Ton
- b. Chilled water supply temperature: 42 °F
- c. Chilled water return temperature: 54 °F
- d. Chiller flow rate: $24 / (54 - 42) = 2$ GPM/ton
- e. Pump flow: $120 \times 2 = 240$ GPM

Equipment Room Pressure Drop:

The total water flow rate required of 240 GPM determines the system components selection and the equipment room pipe and fittings size selection. The system will use Schedule 40 steel piping and Table 1 indicates that 3 1/2" size will carry the design flow. The pressure drops of the system components, including piping and fittings at the equipment room, are as follows:

Component	Cant.	Pressure drop
Chiller's evaporator	1	2.9'
3 ½" Piping (240 GPM from A to B)	32'	1.9'
Triple duty valve	1	2.3'
90°-Elbow	8	5.1'
Flanged gate valve	1	0.2'
Equipment Room Pressure Drop to A-B:		12.4'

Zone 1:

Component	Cant.	Pressure drop
Coil	1	3'
2 ½" Piping (80 GPM from A to D)	200'	9.3'
Screwed tee-branch flow	1	0.7'
90°-Elbow	6	2.3'
3" Piping (180 GPM from D to B)	12'	0.9'
Screwed tee-branch flow	1	1.4'
2 ½" Balance valve (wide open)	1	2.7'
Zone 1 Pressure Drop (Less control valve):		20.3'

Zone 2:

Component	Cant.	Pressure drop
Coil	1	2'
3" Piping (160 GPM from A to C)	3'	0.2'

Screwed tee-line flow	1	0.7'
2" Piping (60 GPM from C to B)	130'	8.6'
Screwed tee-line flow	1	0.5'
90°-Elbow	7	3.5'
2" Balance valve (wide open)	1	1.5'
Zone 2 Pressure Drop (Less control valve):		17'

Zone 3:

Component	Cant.	Pressure drop
Coil	1	5'
3" Piping (160 GPM from A to C)	3'	0.2'
Screwed tee-line flow	1	0.7'
2 ½" Piping (100 GPM from C to D)	220'	15.6'
Screwed tee-branch flow	1	1.1'
90°-Elbow	5	0.6'
3" Piping (180 GPM from D to B)	12'	0.9'
Screwed tee-line flow	1	0.9'
2 ½" Balance valve (wide open)	1	4.2'
Zone 3 Pressure Drop (Less control valve):		29.2'

Control Valves Selection:

In order to provide stable flow conditions, the control valves should be selected for initial pressure drops on the order of three times the coil pressure drop if possible. On the other hand, valves should generally not be sized for over 20' pressure drop because of

velocity problems. The circuit with the highest pressure drop should have its valve selected first, with the other valves selected to help balance their pressure drop to this one.

Zone 3 has the highest pressure drop, with its coil pressure drop being 5' so a valve selection for 15' @ 100 GPM should be attempted. This requires a valve with a Cv of 39. The closest selection available could be a 2" valve with Cv = 34, having a pressure drop of 19.3' at 100 GPM. The total pressure drop of Zone 3 will then be 48.5' (29.2' + 19.3').

Here how you can calculate the valve characteristic?

$$C_v = Q \sqrt{\frac{G}{\Delta P}}$$

Where

- Q = design flow rate (GPM)
- G = specific gravity relative to water
- P = allowable pressure drop across wide open valve (psi)

Water pressure can be expressed as either "psi" (pounds of pressure per square inch) or "feet of head." A column of water 1 foot high exerts 0.433 psi at the bottom and therefore 1 psi is equivalent to 2.31 feet of head.

For our system, 15 feet pressure drop at control valve is equivalent to 6.5 psi [15 x 0.433], therefore

$$C_v = 100 \sqrt{\frac{1}{6.5}} \cong 39$$

At this point, some people would be tempted to go to the valve charts or characteristic curves and select a valve. Don't make the mistake of trying to match a valve with your calculated Cv value. The Cv value should be used as a guide in the valve selection, not a hard and fast rule. Some other considerations are:

- a) Never use a valve that is less than half the pipe size

b) Avoid using the lower 10% and upper 20% of the valve stroke. The valve is much easier to control in the 10-80% stroke range.

Before a valve can be selected, you have to decide what type of valve will be used. For HVAC cooling coil, equal percentage valve is recommended. The valve chart for this type of valve is shown below. This is a typical chart that will be supplied by the manufacturer.

FLOW CHARACTERISTIC	VALVE SIZE		MAXIMUM TRAVEL	PORT DIA.	DESIGNS ED AND ET (FLOW DOWN)					DESIGN ES (FLOW UP)				
					Valve Opening, Percent of Total Travel									
	DIN	Inches	mm	mm	10	30	70	100	100	10	30	70	100	100
					C _v				F _L	C _v				F _L
Equal Percentage	DN 25	1, 1-1/4	19	33.3	.783	2.20	7.83	17.2	.88	.783	1.86	9.54	17.4	.95
	DN 40	1-1/2	19	47.6	1.52	3.87	17.4	35.8	.84	1.54	3.57	17.2	33.4	.94
	DN 50	2	29	58.7	1.66	4.66	25.4	59.7	.85	1.74	4.72	25.0	56.2	.92
	DN 65	2-1/2	38	73.0	3.43	10.8	49.2	99.4	.84	4.05	10.6	45.5	82.7	.93
	DN 80	3	38	87.3	4.32	10.9	66.0	136	.82	4.05	10.0	59.0	121	.89
	DN 100	4	51	111.1	5.85	18.3	125	224	.82	6.56	17.3	103	203	.91
	DN 150	6	51	177.8	12.9	43.3	239	394	.85	13.2	41.1	223	357	.86
	DN 200	8	76	203.2	27.0	105	605	818	.96	25.9	97.8	618	808	.85
					X _v				---	X _v				---
	DN 25	1, 1-1/4	19	33.3	.766	.587	.743	.667	---	.754	.763	.630	.721	---
	DN 40	1-1/2	19	47.6	.780	.716	.690	.679	---	.674	.694	.698	.793	---
	DN 50	2	29	58.7	.827	.774	.702	.687	---	.863	.849	.792	.848	---
	DN 65	2-1/2	38	73.0	.778	.678	.661	.660	---	.747	.745	.783	.878	---
	DN 80	3	38	87.3	.774	.682	.663	.675	---	.768	.761	.754	.757	---
	DN 100	4	51	111.1	.731	.643	.672	.716	---	.722	.739	.718	.822	---
	DN 150	6	51	177.8	.688	.682	.736	.778	---	.723	.767	.808	.816	---
DN 200	8	76	203.2	.644	.636	.725	.807	---	.825	.681	.735	.827	---	

For our case, the 2" valve will work well for our Cv value at about 80-85% of the stroke range. Notice that we're not trying to squeeze our Cv into the 1½" valve which would need to be at 100% stroke to handle our maximum flow. If this valve were used, two consequences would be experienced: the pressure drop would be a little higher than 6.72psi at our design (max) flow and the valve would be difficult to control at maximum flow. If the stroke percentage falls below 10% at our minimum flow, a smaller valve may have to be used in some cases. Judgments plays role in many cases.

Similarly.....

Zone 1 has a pressure drop, exclusive of its control valve, of 20.3', so a valve can be selected for the difference between this and 48.5' to balance it to Zone 3. This difference is 28.2', well over the allowable 20' maximum pressure drop. A valve, to provide 20' resistance at 80 GPM would require a Cv of 27. The closest selection available could be a 2" valve with Cv = 29, having a pressure drop of 17' at 80 GPM. The total pressure drop of Zone 1 will then be 37.3' (20.3' + 17').

Zone 2 requires a valve with a pressure drop of 31.5' (48.5' - 17') to balance it to Zone 3. Such value is again well above the allowable 20' maximum pressure drop. A valve, to provide 20' resistance at 60 GPM would require a Cv of 20. The closest selection available could be a 2" valve with Cv of 22, having a pressure drop of 16.6' at 60 GPM. The total pressure drop of Zone 2 will then be 33.6' (17' + 16.6'). The pressure drops, including control valve, are now as follows:

Zone	Pipe, coil and fittings	Control valve	Total
1	20.3'	17'	37.3'
2	17'	16.6'	33.6'
3	29.2'	19.3'	48.5'

Zone Balance:

In order to balance Zone 1 to Zone 3, the balancing valve will have to be set at 3.8 turns to provide 11.2' (48.5' - 37.3') of additional resistance at the 80 GPM flow. The balancing valve of Zone 2 must be set at 3.2 turns to provide 14.9' (48.5' - 33.6') of additional resistance at the zone rated flow of 60 GPM. The balancing valve of the Zone 3 remains wide open. The settings of each balancing valve will be as follows:

Zone	Valve size	Flow(GPM)	Pressure Drop needed	Setting (turns)
1	2 ½"	80	11.2'	3.8
2	2 ½"	60	14.9'	3.2
3	2 ½"	100	4.2'	4

Total System Pressure Drop:

Once all three zones have been balanced at their design flows, with pressure drops corresponding to Zone 3's pressure drop of 48.5', it is now possible to calculate the total system pressure drop as follows:

Total system pressure drop = Equipment room pressure drop + Zone's pressure drop

Total system pressure drop = 12.4' + 48.5'

Total system pressure drop = 60.9'

Concluding.....

A pump may now be selected for 240 GPM @ 60.9' head.

Section - 6

PUMPING SYSTEM ENERGY EFFICIENCY

The amount of fluid power that a system consumes is a product of head and flow, defined as follows:

$$\text{WHP} = Q \times H \times \text{SG} / 3960$$

Where

- Q = Capacity in gallons per minute
- H = Total Differential Head in absolute feet
- SG = Specific Gravity of the liquid

The constant (3960) is the number of foot-pounds in one horsepower (33,000) divided by the weight of one gallon of water (8.33 pounds).

Brake Horsepower (BHP) is the actual horsepower delivered to the pump shaft, defined as follows:

$$\text{BHP} = Q \times H \times \text{SG} / 3960 \times P\eta$$

Where

- Q = Capacity in gallons per minute
- H = Total Differential Head in absolute feet

- SG = Specific Gravity of the liquid
- $P\eta$ = Pump efficiency as a percentage

Brake horsepower is measured at the pump input shaft by a torque-meter coupling or similar device. The difference between brake horsepower and hydraulic horsepower is the amount of power consumed by mechanical losses, noise, heat, viscous drag, and internal recirculation. The actual or brake horsepower (BHP) of a pump will be greater than the WHP by the amount of losses incurred within the pump through friction, leakage and recirculation. Such losses are accounted for by the pump efficiency ($P\eta$) and are defined as:

$$\text{Pump Efficiency } (P\eta) = \text{WHP} / \text{BHP}$$

The motor power required to generate these head and flow conditions will be higher than BHP because of motor inefficiencies. The electric horsepower requirement for driving the pump is given by following equation:

$$\text{EHP} = Q \times H \times \text{SG} / (3960 \times P\eta \times M\eta)$$

Where

- Q = Capacity in gallons per minute
- H = Total Differential Head in absolute feet
- SG = Specific Gravity of the liquid
- $P\eta$ = Pump efficiency as a percentage
- $M\eta$ = Motor efficiency as a percentage

Overall efficiency ($O\eta$) of the pump is thus the ratio of the energy delivered by the pump to the energy supplied to the motor input terminals, and takes into account motor and pump efficiency i.e.

$$\text{Overall efficiency } (O\eta) = P\eta \times M\eta$$

Or

Overall efficiency ($O\eta$) = WHP/EHP

Energy is normally expressed in terms of kilowatt - hours (kWh) per unit volume. Typical units of measure and the associate calculations are presented as follows.

$$\mathbf{kW = EHP \times 0.746}$$

Or

$$\mathbf{kW = BHP \times 0.746 / M\eta}$$

Pumps have varying efficiency levels. A high efficiency pump uses less energy (\$\$\$) to operate than a low efficiency pump. Efficiencies range widely, from 35% to more than 90%, and they are a function of many design characteristics. If possible, it is best to avoid any pump that has an efficiency of 55% or less. (55% efficiency is the industry standard used to estimate the performance of a pump when the actual efficiency is unknown.)

Systems with significant annual operating hours incur high operating and maintenance costs relative to initial equipment purchase costs. Inefficiencies in high-run-time, oversized systems can add significantly to annual operating costs.

Improving Pump Efficiency in HVAC Chilled Water Systems

In chilled water systems, pumping normally draws from around 6 to 12 % of the total annual plant energy consumption. A common cause of energy waste is that many chilled and condenser water circulation systems are significantly oversized and then “throttled” to produce the desired performance. In such systems, pumps are selected to provide a certain amount of fluid flow while overcoming frictional resistance as the fluid moves through pipes, coils, valves, and other piping system components.

Often, pumps are oversized, meaning that they are capable of overcoming a higher level of pressure than will actually be experienced in operation. Because of the way in which a centrifugal pump operates, it circulates more fluid when working against lower pressure than when working against higher pressure, and this is not usually desirable in HVAC applications.

In order to adjust the flow to what is actually required, a valve is installed on the discharge side of the pump and partially closed in order to choke or throttle the flow of fluid leaving the pump. By adjusting this false pressure drop, it is possible to achieve the desired flow. While a throttling valve is useful for making minor adjustments to fluid flow and balancing the system, it is common for pumps to be selected in exceedingly conservative fashion with the knowledge that adjusting this valve after the system is installed will atone for any design flaws. This approach penalizes the building owner every hour the pump is in operation, year after year.

Energy use in pumping systems may be reduced by sizing pumps based upon the realistic calculations on flow and head. A 10% error in head calculations will have significant penalty on pump energy consumption, no matter how best pump efficiency is selected.

The following design strategies can reduce energy use of pumping systems:

Keep the fluid velocity down: Friction increases as the square of fluid velocity, so keeping velocities low can substantially reduce pressure loss. Size pipes for a fluid velocity that does not exceed 4 feet per second and, depending on the pipe sizes involved, consider selecting the next larger pipe diameter that will result in acceptable pipe velocities. The longer the lengths of pipe involved with a project, the greater the savings potential will be for this strategy.

Keep the temperature differential up: A chilled water system that is designed based upon a 10° F temperature rise through the cooling coils must circulate about 2.4 GPM/ton, whereas a system with a 20° F difference circulates only about 1.2 GPM/ton, resulting in a nominal savings of 50 percent of pumping energy. Selecting chilled water coils that provide a larger temperature difference will reduce the size of piping, pumps, motors, and piping accessories, which can offset some or all of the added cost of the coils. A higher temperature differential will however increase the chiller energy consumption and it is important to economically work out the trade-off.

In general the recommended chilled water design supply water temperature shall be 42°F, with a minimum return water temperature of 58°F to maximize the usable lifetime (optimize pipe size of existing piping) of water systems.

Keep the piping system simple: Avoid arranging piping in exceedingly complicated configurations that use numerous changes of direction to get around beams, electrical conduit, or other obstacles. Shorter piping paths mean less piping, less welding, and reduced pressure loss. Minimize the use of unnecessary valves, flow control devices, turns, transitions, and other “pressure wasters.” Note the following tips:

- Design pipe changes off pumps using long radius reducing elbows or eccentric reducers to maintain top of pipe level.
- Provide piping support such that piping weight is not transferred to pump flanges or casing.
- Provide supports under elbows attached to inertia bases on pump suction and discharge.
- Provide a minimum of five straight pipe diameters at pump inlet connections. Suction diffusers only allowed if space constraints require their use.
- Provide line size isolation valve and strainer on pump suction piping.
- Provide line sized, spring-loaded silent check valve and isolation valve on pump discharge piping.
- Provide sectional valves on each branch and riser, close to main, where branch or riser serves 2 or more hydronic terminals or equipment connections.
- Use pressure-independent control valves that can eliminate the need for flow control devices.

Use variable flow configuration and controls: Conventional chilled water plants distribute water at constant flow rate, regardless of the actual cooling demand. Since most air-conditioning systems only reach peak load a few hours a year, energy is wasted by continually running the pumps at constant flow (speed). An efficient distribution system use variable flow that tracks the variable thermal load. Pump horsepower varies as the cube of fluid flow, so cutting flow by one-half can reduce horsepower by one-eighth of its original value. An effective way to do this is to install variable speed drives (VSDs) on the pumps.

Example:

A chilled water pump is designed for a constant flow rate of 1040 GPM and is driven by 30 HP motor. The average flow rate requirement is 700 GPM. It is recommended to put a VSD on the pump. Calculate the energy savings if the existing operating hours are 3,300 per year, and the pump's energy consumption is 66,900 kWh per year. Calculate the \$ savings if the energy cost is \$0.08 per kWh and payback period if the cost of the VSD is \$7,175.

Estimated new annual energy consumption:

Since pump horsepower varies as the cube of fluid flow, the energy consumption will vary in power of cube, or

$$(66,900) * (700 \div 1,040)^3 = 20,400 \text{ kWh per year}$$

Estimated annual energy savings:

$$(66,900 - 20,400) * (\$0.08/\text{kWh}) = \$3,720 \text{ per year.}$$

$$\text{Simple payback} = \$7,175 \div \$3,720 = 1.9 \text{ years}$$

In some cases, pump selection is based on future predicted flows or extremely conservative friction head losses. When such criterion is used in the selection process, the pump(s) will run at a fraction of the design rating and the result is inefficient operation and high costs of maintenance. VSD is better option for such a scenario.

Evaluate variable flow piping options: More and more new chiller plants are defying the long-held design wisdom that flow rates through the chiller should not vary. Such plants use variable speed drives to control the primary chilled water pumps so that flow through the chillers and out to the coils varies with the demand for chilled water, instead of the traditional "primary/secondary" approach method by which only flow to the coils is varied. If properly implemented, the variable flow piping approach uses less physical space, requires fewer components, and is intuitive to many building engineers.

Specify efficient pumps and premium efficiency motors: Once an efficient system concept is established, the next step is to select pumps that are efficient under the anticipated operating conditions. When referring to manufacturers' pump performance

curves, select a pump where the design pressure and flow are as close to the point of highest efficiency as possible. This will minimize the brake horsepower requirements, and therefore the size of the motor required to drive the pump. In new construction, always choose a premium efficiency motor. It is almost always cost-effective to spend a bit extra when purchasing the motor, because most motors use many times their initial cost in energy over their life.

Summary

During the pump selection process, only pumps having high efficiencies (above 70%) for the design discharge should be considered for a system. It is common practice to select a pump capable of producing higher head and larger flow rate (approximately 10%) than the design parameters. This will assure that as the pump wears, its performance will remain adequate. The impact of low efficiency on power consumption is very significant. Total pump operating costs may justify the purchase of a more expensive pump that can operate with higher efficiency under needed conditions. Economics is often the primary criterion for pump selection. It is important to estimate the cost of pump operation and consider this cost together with the initial cost of the pumping equipment.

Appendix A

GLOSSARY OF BASIC PUMPING SYSTEM TERMS

Absolute pressure – Total force per unit area in a system (includes vapor pressure and atmospheric pressure).

Adjustable speed drives (ASDs) – Devices that allow control of a pump's rotational speed. ASDs include mechanical devices such as hydraulic clutches and electronic devices such as eddy current clutches and variable frequency drives.

Affinity laws – A set of relationships that tie together pump performance characteristics such as pressure, flow, and pump speed.

Allowable operating region – The precise limits for minimum and maximum flow in a pump.

Axial pump – Sometimes called a propeller pump, this type of pump has a single-inlet impeller; the flow enters axially and discharges nearly axially.

Backpressure – The pressure on the discharge side of the pump.

Bearing – A device that supports a rotating shaft, allowing it to spin while keeping it from translating in the radial direction. A thrust bearing keeps a shaft from translating in the axial direction.

Best efficiency point (BEP) – Commonly used to describe the point at which a centrifugal pump is operating at its highest efficiency, transferring energy from the prime mover to the system fluid with the least amount of losses.

Brake horsepower (BHP) – The amount of power (measured in units of horsepower) delivered to the shaft of a motor-driven piece of equipment.

Cavitation – A phenomenon commonly found in centrifugal pumps in which the system pressure is less than the vapor pressure of the fluid, causing the formation and violent collapse of tiny vapor bubbles.

Centrifugal pump – A pump that relies on a rotating, vaned disk attached to a driven shaft. The disk increases fluid velocity, which translates to increased pressure.

Check valve – A valve that allows fluid to flow in one direction only; it is generally used to maintain header pressure and protect equipment from reverse flow.

Deadhead – A condition in which all the discharge from a pump is closed off.

Dynamic head – The component of the total head that is attributable to fluid motion (also known as velocity head).

Gauge pressure – A measure of the force per unit area using atmospheric pressure as the zero reference.

Head – A measure of pressure (expressed in feet) indicating the height of a column of system fluid that has an equivalent amount of potential energy.

Header – A run of pipe that either supplies fluid to (supply header) or returns fluid from (return header) a number of system branches.

Heat exchanger – A device that transfers heat from one fluid to another.

Horsepower (hp) – A measure of the work or energy flux per unit time; the rate at which energy is consumed or generated.

Impeller – A centrifugal pump component that rotates on the pump shaft and increases the pressure on a fluid by adding kinetic energy.

Kinetic energy – The component of energy that is due to fluid motion.

Load factor – A ratio of the average capacity to the rated full capacity (in terms of power).

Mechanical seal – A mechanical device for sealing the pump/shaft interface (as opposed to packing).

Minimum flow requirement – A manufacturer specified limit that represents the lowest flow rate at which the pump can operate without risking damage from suction or discharge recirculation.

Motor – An electric machine that uses either alternating current (ac) or direct current (dc) electricity to spin a shaft. Typically, this shaft is coupled to a pump. Occasionally, however, mechanisms such as a slider/crank convert this rotation to axial movement to power piston pumps.

Motor controller – An electric switchbox that energizes and de-energizes an electric motor.

Packing – A form of a pump seal that prevents or minimizes leakage from the pump stuffing box. Packing is usually a flexible, self-lubricated material that fits around the pump shaft, allowing it to spin while minimizing the escape of system fluid between the shaft and the pump housing.

Preferred operating region – The region on a pump curve where flow remains well controlled within a range of capacities. Within this region hydraulic loads, vibration, or flow separation will not significantly affect the service life of the pump.

Performance curve – A curve that plots the relationship between flow and head for a centrifugal pump. The vertical axis contains the values of head while the horizontal axis contains flow rates. Since flow rate varies with head in a centrifugal pump, performance curves are used to select pumps that meet the needs of a system.

Pony pump – A pump that is usually associated with a larger pump in a multiple-pump configuration. The pony pump typically handles normal system requirements, while the larger pump is used during high demand periods.

Positive displacement pump – A pump that pressurizes a fluid using a collapsing volume action. Examples include piston pumps, rotary screw pumps, and diaphragm pumps.

Pressure – Force per unit area; commonly used as an indicator of fluid energy in a pumping system (expressed in pounds per square inch).

Prime mover – A machine, usually an electric motor, that provides the motive force driving a pump.

Radial pump – In this type of pump, the liquid enters the impeller at the hub and flows radially to the periphery.

Recirculation – A flow condition which occurs during periods of low flow, usually below the minimum flow requirement of a pump. This condition causes cavitation-like damage, usually to the pressure side of an impeller vane.

Relief valve – A valve that prevents excessive pressure buildup. Often used on the discharge side of a positive displacement pump and in applications where thermal expansion of a system fluid can damage system equipment.

Specific gravity – The ratio of the density of a fluid to the density of water at standard conditions. **specific speed** – An index used to measure the performance of an impeller; it represents the speed required for an impeller to pump one gallon per minute against one foot of head and is defined by the equation:

$$N_s = \frac{n \sqrt{Q}}{H^{3/4}}$$

Static head – The head component attributable to the static pressure of the fluid.

Stiction – Static friction (frictional resistance to initial motion).

Stuffing box – The part of a pump where the shaft penetrates the pump casing.

Suction specific speed – An index used to describe the inlet conditions of a pump; it is

defined by the equation:
$$S = \frac{n \sqrt{Q}}{NPSHR^{3/4}}$$

Head – A measure of the total energy imparted to the fluid by a centrifugal pump. This value includes static pressure increase and velocity head.

Valve – A device used to control fluid flow in a piping system. There are many types of valves with different flow control characteristics, sealing effectiveness, and reliability.

Valve seat – The component of a valve that provides the sealing surface. Some valves have just one seat; others have a primary seat, which prevents leakage across the valve, and a back seat, which prevents leakage from the valve to the environment.

Vapor pressure – The force per unit area that the fluid exerts in an effort to change the phase from a liquid to a vapor. This pressure is a function of a fluid's chemical and physical properties, and its temperature.

Variable frequency drive (VFD) – A type of adjustable speed drive that controls the speed of ac motors by regulating the frequency of the electric power. VFDs are the most common type of adjustable speed drives and can significantly reduce energy use by matching the speed of driven equipment to required output.

Velocity head – The component of the total head that is attributable to fluid motion (also known as dynamic head).

Viscosity – The resistance of a fluid to flow when subjected to shear stress.