



**PDHonline Course M331 (5 PDH)**

---

# **HVAC for Cleanroom Facilities**

*Instructor: A. Bhatia, B.E.*

**2020**

**PDH Online | PDH Center**

5272 Meadow Estates Drive  
Fairfax, VA 22030-6658  
Phone: 703-988-0088  
[www.PDHonline.com](http://www.PDHonline.com)

An Approved Continuing Education Provider

# HVAC for Cleanroom Facilities

*A. Bhatia, B.E.*

Indoor air quality is of paramount importance for human comfort and health. Air, whether it is from outside or re-circulated within the area, acts as a vehicle for airborne contaminants brought in by the movement of people, material, etc. Since many of these airborne contaminants are harmful either to products or people working in such environments their removal is necessary on medical, legal, social or financial grounds.

Cleanrooms are specially constructed, environmentally controlled enclosed spaces where the concentration of airborne particles (contaminants) is kept within specified limits. In industry, cleanrooms are used in the manufacturing of electronic hardware such as integrated circuits (ICs) and hard drives. In biotechnology and medicine, cleanrooms are used when it is necessary to ensure an environment free of bacteria, viruses, or other pathogens.

Four fundamental rules apply to cleanrooms.

- 1) First, contaminants must not be introduced into the controlled environment from the outside.
- 2) Second, the apparatus or equipment within the controlled environment must not generate or otherwise give rise to contaminants (for example as a result of friction, chemical reactions, or biological processes).
- 3) Third, contaminants must not be allowed to accumulate in the controlled environment.
- 4) Fourth, existing contaminants must be eliminated to the greatest extent possible, and as rapidly as possible.

These requirements are defined in Federal industry standard 209 and ISO 14644-1. It takes an incredible amount of technology to achieve and maintain these objectives. The HVAC system for cleanrooms is a specialized field requiring thorough understanding of cleanliness guidelines, airflow streams, room pressurization, temperature, humidity and filtration requirements, knowledge of codes and standards, specialty equipment, instrumentation and

control, and many more details. This course will describe some basic requirements of HVAC design for cleanroom applications.

### **Airborne particles Characteristics**

Airborne particles are solids suspended in the air. For our purposes, particles are defined as bodies with:

- 1) Definite physical boundaries in all directions.
- 2) Diameters ranging from 0.001 micron to 100 microns\*.
- 3) Liquid or solid phase material characteristics.

\*The size of contaminants and particles are usually described in microns; one micron is one-millionth of a meter. In English units one micron equals 1/25,400 inch. To give a perspective, a human hair is about 75-100 microns in diameter. A particle of 0.5 micron (200 times smaller than the human hair) can cause major disaster in a cleanroom.

### **Sources of Contamination**

The airborne contamination level of a cleanroom is largely dependent on the particle generating activities in the room, as well as the personnel occupying the room. It is found that many of these contaminants are generated from five basic sources (1) the facilities, (2) people, (3) tools, (4) fluids and (5) the product being manufactured. Review the list below to gain a better understanding of where the contamination originates.

- 1) Facilities
  - Walls, floors and ceilings
  - Paint and coatings
  - Construction material (sheet rock, saw dust etc.)
  - Air conditioning debris
  - Room air and vapors
  - Spills and leaks
- 2) People
  - Skin flakes and oil
  - Cosmetics and perfume

- Spittle
  - Clothing debris (lint, fibers etc.)
  - Hair
- 3) Tool Generated
- Friction and wear particles
  - Lubricants and emissions
  - Vibrations
  - Brooms, mops and dusters
- 4) Fluids
- Particulates floating in air
  - Bacteria, organics and moisture
  - Floor finishes or coatings
  - Cleaning chemicals
  - Plasticizers (out-gasses)
  - Deionized water
- 5) Product generated
- Silicon chips
  - Quartz flakes
  - Cleanroom debris
  - Aluminum particles

This is a partial list of some of the commonly known contaminants. Preventing these contaminants from entering the cleanroom environment is the key objective of cleanroom design and use.

### **What is a Cleanroom?**

A cleanroom is defined by ISO14644-1 as a room in which the concentration of airborne particles is controlled, and which is constructed and used in a manner to minimize the introduction, generation, and retention of particles inside the room and in which other relevant parameters, e.g. temperature, humidity, and pressure, are controlled as necessary.

## Cleanroom Classification

Cleanroom specifications for particulate matter (such as dust) are defined according to the maximum allowable particle size (diameter), and also according to the maximum allowable number of particles per unit volume. For non-particulate contaminants, the maximum allowable density in terms of microbes per cubic meter, or molecules per cubic meter, is specified.

The determination of how clean an area is depends on the class number that it is designed to. According to Federal Standard 209, A to D versions, class number refers to the maximum number of particles of 0.5 micron size or bigger that would be allowed in one cubic foot of cleanroom air.

Maximum number of particles in Air (particle per cubic feet of air)

<b>Class</b>	<b>0.1 <math>\mu\text{m}</math></b>	<b>0.2 <math>\mu\text{m}</math></b>	<b>0.3 <math>\mu\text{m}</math></b>	<b>0.5 <math>\mu\text{m}</math></b>	<b>5 <math>\mu\text{m}</math></b>
1	35	7	3	1	
10	350	75	30	10	
100	3500	750	300	100	
1,000				1,000	7
10,000				10,000	70
100,000				100,000	700

A Class 100 cleanroom, for example, would not contain more than 100 particles bigger than 0.5 micron in a cubic foot of air.

A Class 10,000 - Particle count not exceeding a total of 10,000 particles per cubic foot of a size 0.5 microns and larger or 70 particles per cubic foot of a size 5.0 microns and larger.

### Classes and their Typical Uses

- Class 1 & 10 - production laboratories for electronic integrated circuits...
- Class 100 - production areas for photo labs, medical implants...
- Class 10,000 - production locales for TV tubes, hospital operating theaters...
- Class 100,000 - production of ball bearings...

### ISO Classification of Cleanrooms

ISO 14644 classification for cleanrooms is based on the formula

$$C_n = 10N (0.1 / D)^{2.08}$$

Where

- $C_n$  = maximum permitted number of particles per cubic meter equal to or greater than the specified particle size, rounded to whole number
- $N$  = is the ISO class number, which must be a multiple of 0.1 and be 9 or less
- $D$  = is the particle size in micrometers

Maximum Concentration Limits (particles/m<sup>3</sup> of air)

Class	0.1 μm	0.2 μm	0.3 μm	0.5 μm	1 μm	5 μm
ISO 1	10	2				
ISO 2	100	24	10	4		
ISO 3	1000	237	102	35	8	
ISO 4	10000	2370	1020	352	83	
ISO 5	100000	23700	10200	3520	832	29
ISO 6	1000000	237000	102000	35200	8320	293
ISO 7				352000	83200	2930
ISO 8				3520000	832000	29300
ISO 9				35200000	8320000	293000

An ISO 1 cleanroom has the lowest levels of contamination, while an ISO 9 has the highest allowable level. To give a perspective, the ambient air outside in a typical urban environment might contain as many as 35,000,000 particles per cubic meter, 0.5 um and larger in diameter, corresponding to an ISO class 9 cleanroom.

**Cleanroom class comparison (ISO v/s Federal Std. 209)**

ISO is based on metric measurements whereas Federal Standard 209 is based on imperial measurements. The classes, according to ISO14644, are in terms of class levels 3, 4, 5...of airborne particulate cleanliness corresponding to 1, 10, 100.....class Fed 209 standards. A Class 5 means that less than 3,520 particles (0.5 microns in size) are present per cubic meter, which equals 100 particles per cubic foot.

<b>ISO</b>	<b>Federal Std. 209*</b>
ISO 3	1
ISO 4	10
ISO 5	100
ISO 6	1,000
ISO 7	10,000
ISO 8	100,000

\*In United States, Federal Standard 209E (FED-STD-209E) was used until the end of November 2001 to define the requirements for cleanrooms. On November 29, 2001, these standards were superseded by the publication of ISO specification 14644.

**Key Elements of Cleanroom Design**

Four basic components define a controlled environment:

- 1) *Cleanroom Architecture* – Materials of construction and finishes are important in establishing cleanliness levels and are important in minimizing the internal generation of contaminants from the surfaces.
- 2) *The HVAC System* – The integrity of the cleanroom environment is created by the pressure differential compared with adjacent areas through heating, ventilation and air-conditioning system. The HVAC system requirements include:
  - Supplying airflow in sufficient volume and cleanliness to support the cleanliness rating of the room.
  - Introducing air in a manner to prevent stagnant areas where particles could accumulate.
  - Filtering the outside and re-circulated air across high efficiency particulate air (HEPA) filters.
  - Conditioning the air to meet the cleanroom temperature and humidity requirements.
  - Ensuring enough conditioned makeup air to maintain the specified positive pressurization.
- 3) *Interaction Technology* - Interaction technology includes two elements: (1) the movement of materials into the area and the movement of people and (2) maintenance and cleaning. Administrative instructions, procedures and actions are necessary to be made about the logistics, operation strategies, maintenance and cleaning.
- 4) *Monitoring systems* - Monitoring systems include a means of indicating that the cleanroom is functioning properly. The variables monitored are the pressure differential between the outside environment and the cleanroom, temperature, humidity and, in some cases, noise and vibrations. Control data should be recorded on a routine basis.



## Section-2 HVAC SYSTEM DESIGN FOR CLEAN FACILITY

HVAC systems in cleanrooms are dramatically different from their counterparts in commercial buildings in terms of equipment design, system requirements, reliability, size and scale.

### What differentiates cleanroom HVAC to conventional systems?

Cleanroom design encompasses much more than conventional temperature and humidity control. Typical office building air contains from 500,000 to 1,000,000 particles (0.5 microns or larger) per cubic foot of air. A Class 100 cleanroom is designed to never allow more than 100 particles (0.5 microns or larger) per cubic foot of air. Class 1000 and Class 10,000 cleanrooms are designed to limit particles to 1000 and 10,000 respectively. A cleanroom differs from a normal comfort air conditioned space, in the following ways.

1. Increased Air Supply: Whereas comfort air conditioning would require about 2-10 air changes/hr, a typical cleanroom would typically require 20 - 60 air changes and could be as high as 600 for absolute cleanliness. The large air supply is mainly provided to eliminate the settling of the particulate and dilute contamination produced in the room to an acceptable concentration level.
2. The use of high efficiency filters: The use of high efficiency particulate air (HEPA) filters having filtration efficiency of 99.97% down to 0.3 microns is another distinguishing feature of cleanrooms. The HEPA filters for stringent cleanrooms are normally located at the terminal end and in most cases provide 100% ceiling coverage.
3. Room pressurization: The cleanroom is positively pressurized (to 0.05 in-wc) with respect to the adjacent areas. This is done by supplying more air and extracting less air from the room than is supplied to it.

There is much more into the design of cleanrooms in terms of details of technology of equipment, the type of filtration, efficiency, airflow distribution, amount of pressurization, redundancy, noise issues, energy conservation etc...etc...

### FILTRATION SYSTEM

Any air introduced in the controlled zone needs to be filtered. Air filtration involves the separation of "particles" from airstreams. Their removal method is almost as diverse as the

size ranges of the particulates generated. Understanding separation techniques requires an exact definition of what particles are. As particles become very small, they cease to behave so much like particles as they do gas phase molecules. It is difficult to tell whether such small particles are actually suspended in air (particles) or diffused throughout it (gas or vapor). The bottom boundary where particles act as true particles is about 0.01 micron. The normal theory of separation does not apply to particles below this size and removing them from air requires techniques reserved for gaseous materials. Particles above 0.01 micron are usually considered to be filterable.

All air entering a cleanroom must be treated by one or more filters. High-efficiency particulate air (HEPA) and ultra-low penetration air (ULPA) filters are the most common filters used in cleanroom applications.

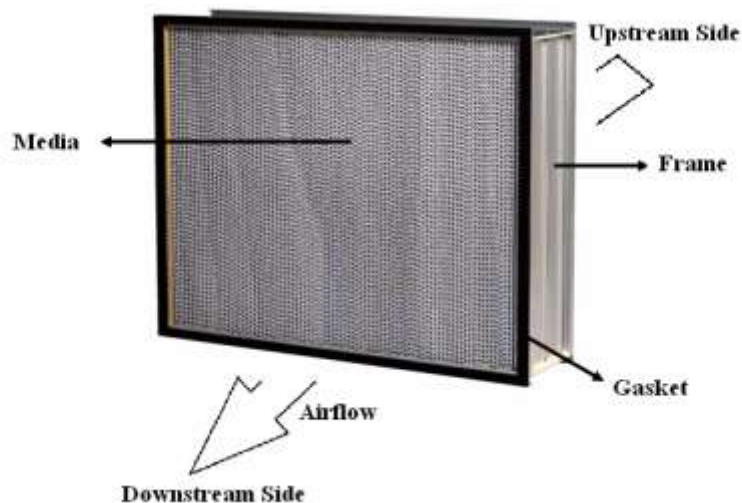

Air filters are constructed of filter media, sealants, a frame, and sometimes a faceguard and/or gasket.

- 1) Media is the filtering material. Common types of media include glass fiber, synthetic fiber, non-woven fiber, and PTFE. High efficiency filters use sub-micron glass fiber media housed in an aluminum framework.
- 2) Sealant is the adhesive material that creates a leak-proof seal between the filter media and the frame.

- 3) Frame is where the filter media is inserted. It can be made from a variety of materials including aluminum, stainless steel, plastic or wood.
- 4) Faceguard is a screen attached to the filter to protect the filter media during handling and installation.
- 5) Gasket is a rubber or sponge like material used to prevent air leaks between the filter and its housing by compressing the two together.

Air enters the filter through the upstream side. It flows through the filter, contaminants are taken out of the air, and the 'clean' air exits through the downstream side. How 'clean' the air is on the downstream side depends on the efficiency of the filter.

### **Filtration Principles**

Filtration of particles relies on four main principles: (1) inertial impaction, (2) interception, (3) diffusion, and (4) electrostatic attraction. The first three of these mechanisms apply mainly to mechanical filters and are influenced by particle size.

- 1) Impaction occurs when a particle traveling in the air stream *deviates* from the air stream (due to particle inertia) and collides with a fiber. Generally impaction filters can only satisfactorily collect particles above 10 microns in size and therefore are used only as pre-filters in multi-stage filtration systems. The higher the velocity of air stream, the greater is the energy imparted to the particles and greater is the effectiveness of the principle of impaction.
- 2) Interception occurs when a large particle, because of its size, *collides* with a fiber in the filter that the air stream is passing through. In this method, particles are small enough to follow the air stream. The particles come in contact with the fibers and remain "stuck" to the fibers because of a weak molecular connection known as 'Van-der-Waals' Forces.
- 3) Diffusion occurs when the random (Brownian) motion of a particle causes that particle to contact a fiber. Diffusion works with very small particles and works in HEPA and ULPA filters. The particles are so small that they move in a random motion causing the particle to acquire a vibration mode. Because of this vibration mode, the particles have a good chance of coming in contact with the fibers. The smaller the particle, the stronger this

effect is. For large particles, over one micron in diameter, this filtration mechanism has virtually no effect.

In the order list above, the most critical areas lie between interception and diffusion. Impaction and interception are the dominant collection mechanisms for particles larger than 1  $\mu\text{m}$ , and diffusion is dominant for particles smaller than 1  $\mu\text{m}$ .

- 4) Electrostatic attraction, the fourth mechanism, plays a very minor role in mechanical filtration. If a charged particle passes through an electrostatic field, it is attracted to an oppositely charged body. Such charges can be generated and imparted to particles in an airstream in much the same way as static charges develop during the combing of one's hair or just walking across a rug.

The typical electrostatic air filter is made from polyester or polypropylene strands that are supposedly charged as the air passes through them. Whether particle charges are induced by applying energy to a dirty airstream or occur naturally, they can be valuable tools in increasing air cleaning effectiveness.

### **Filter Media Rating**

Air filters are commonly described and rated based upon their collection efficiency, pressure drop (or airflow resistance), and particulate-holding capacity. The American Society of Heating, Refrigerating, and Air Conditioning Engineers (ASHRAE) developed standards 52.1-1992 and 52.2-1999 that classify filters in terms of "Arrestance" and "Efficiency".

Standard 52.1-1992 measures arrestance, dust spot efficiency, and dust holding capacity. Arrestance means a filter's ability to capture dust and describes how well an air filter removes larger particles such as dirt, lint, hair, and dust. The dust holding capacity of a filter is the amount by weight of standard dust that the filter will hold without exceeding the resistance 0.18 inch-w.c. for low-resistance filters, 0.50 inch-w.c. for medium-resistance filters and 1.0 inch-w.c. for high-resistance filters. Be aware that, arrestance values may be high; even for low-efficiency filters, and do not adequately indicate the effectiveness of certain filters for chemical or biological protection. Dust spot efficiency measures a filter's ability to remove large particles, those that tend to soil building interiors. Dust holding capacity is a measure of the total amount of dust a filter is able to hold during a dust loading test. Dust arrestance can be expressed as

$$\mu_a = 1 - C_a / C_b$$

Where

- $\mu_a$  = dust arrestance
- $C_a$  = dust concentration after filter
- $C_b$  = dust concentration before filter

Since large particles make up most of the weight in an air sample, a filter could remove a fairly high percentage of those particles while having no effect on the numerous small particles in the sample. Thus, filters with an arrestance of 90 percent have little application in cleanrooms.

ASHRAE Standard 52.2-1999 measures the particle size efficiency (PSE). *Efficiency* measures the ability of the filter to remove the fine particles from an airstream by measuring the concentration of the material upstream and downstream of the device. If a supplier of filter only indicates efficiency as 95% or 99%, it does not really mean anything unless *it specifies the particle size range*.

The ASHRAE Standard 52.2-1999 quantifies filtration efficiency in different particle size ranges and rates resulting a MERV (Minimum Efficiency Reporting Value) between 1 and 16. This numbering system makes it easier to evaluate and compare mechanical air filters and eliminates some of the confusion regarding the overall effectiveness of any type of a mechanical air filter on removing airborne particulates, especially those that are less than 2 microns in size. A higher MERV indicates a more efficient filter.

### **HEPA filters**

HEPA stands for High Efficiency Particulate Air. The HEPA filters work on diffusion principle to remove particulate matter and are extremely important for maintaining contamination control. These filter particles as small as 0.3  $\mu\text{m}$  (microns) with a 99.97% minimum particle-collective efficiency. This is remarkable considering that the outside air we breathe may contain up to 5 million suspended particles of dust, smog, and pollen in one cubic foot.

These filters typically use glass fiber media and are available in thicknesses of 6" and 12". These have pressure drop of 1 inch- w.c. when clean and generally need to be replaced when the pressure drop exceeds 2 inch- w.c.

HEPA air filters are not MERV rated since they exceed the ASHRAE test protocol 52.2 used in determining the MERV ratings. In fact, HEPA air filters are the ONLY mechanical air filters that are tested and certified to meet a specific efficiency at a specific particle size. All HEPA air filters must meet a minimum efficiency of 99.97% at 0.3 microns.

### **ULPA filters**

ULPA stands for Ultra Low Particulate Air. Growing market demand from advanced science and technology business applications led to development of ULPA filters which provide a minimum of 99.999% efficiency (0.001% maximum penetration) for 0.3 micron particles for achieving better cleanliness classes and cleaner working environments. These are used for ultra-cleanrooms, where contamination levels have to be controlled at levels higher than that which can be achieved with conventional HEPA filters.

Boron free ULPA filters of 99.9997% efficiency for particles down to 0.12 micron size for Class 10 and Class 1 cleanrooms are specifically used in electronic/semiconductors/ wafer manufacturing industries, where tolerances to contamination levels above 0.12 micron are also very critical.

The selection of HEPA and ULPA filter efficiencies seems to be insignificant. For example, look at the fractional penetration of a HEPA filter at 99.97 and 99.9997%. A 99.97% efficient filter has a fractional penetration of 0.0003; while a 99.99% filter's fractional penetration is 0.0001. This means that a 99.99% filter is three times more efficient in removing 0.3-micron particles. This can be a large difference in many clean room applications.

### **Filter Testing**

The efficiency of filter is of paramount importance and must be measured in an appropriate way. Typically the filters are shop tested and only provide the quality certification for required efficiency to the end user. But following installation, a check of the filter seals is recommended on a ninety-day basis, with a complete scan of the filters two times a year. There are five fundamentally different methods used to evaluate efficiency: (1) The Particle

Count Method; (2) The Weight Method; (3) The Atmospheric Dust Spot Efficiency Method; (4) The Cold DOP Method and (5) The Hot DOP Method.

- 1) *The Particle Count Method*: In this method, actual particle count per unit volume of air is determined through microscopic analysis of the air sample. This procedure is extremely tedious and is susceptible to human error. The dust concentration must be quite low (or the sampling time must be unreasonably short) because the sample cannot be allowed to become too dense to count.
- 2) *The Weight Method*: The weight method indicates the weight of the dust removed by the filter as a percentage of the weight of dust in the air before filtering. The Weight Arrestance Test is a simple test which involves feeding a synthetic dust to a filter and rationing the weight of dust exiting the filter to the weight of dust originally fed into the filter. This method is very popular and easy to use. However, it has some shortcomings because weight measurements give predominantly the weight of the largest particles in the sample. Since small particles have little mass, this method offers almost no way of factoring small particle collection efficiency. Implications of the weight method are very important. Most, perhaps all, impingement-type filter manufacturers claim more than 80% efficiency for their products. They may be right, but only from one point of view. If the weight of the particulate matter collected by their filters is compared with the total weight of the particle samples from unfiltered air, they honestly obtain 80% efficiency or more by weight. Perhaps the filter traps only the 300 largest of the 300,000 particles actually in the air, but these 300 captured particles weigh enough to account for 80% of the total weight.
- 3) *The Atmospheric Dust Spot Efficiency Method*: Where small-particle efficiency is critical, the Dust Spot Test is often used. Here standard ambient air is passed through the test filter and the airstream has special test filters in front of and behind the test filter to monitor the presence of airborne particulate. Over time, both filters become soiled and are measured optically for relative soiling. These results are then translated into a filter efficiency rating. The justification for using such a test is that it is based on one of the observable effects of air pollution-the soiling effect. One drawback to the Dust Spot Test is that it uses atmospheric air. Because this air changes constantly, it is difficult to obtain repeatability for verification. As a result, many tests have to be run and the data averaged.

- 4) *The Cold DOP Test:* To overcome the drawback of the Dust Spot Test, the Cold DOP (Di-octyl Phthalate) test can be used. Cold DOP generators produce aerosol at room temperature, with particles ranging in size from 0.2 to 1.2 microns and with a mean diameter of 0.7 micron. The aerosol is introduced to the unit being tested and light scattering, due to particle concentration, is measured at the inlet and outlet of the unit. Because light scattering varies in direct proportion to particle concentration, the collecting efficiency of the unit can be expressed as a function of the difference in light scattering measured at the inlet and outlet at any given time.
- 5) *The Hot DOP Test:* In this test, DOP is evaporated by heat and condensed to form 0.3 micron particles with very little variation in size. This particle size is the most difficult for all kinds of air cleaners to collect and will normally produce a slightly lower efficiency on all kinds of air cleaning devices than the Cold DOP Method.

HEPA filters are tested using Hot DOP method. Here DOP is boiled and the vapor injected into the airstream in front of the test filter. As the vapor condenses back to ambient temperature, it forms very uniform droplets about 0.3 micron in diameter. By the use of light scattering instrumentation, upstream and downstream particle concentrations can be measured. In essence, if 10,000 .3 micron sized particles are blown into a HEPA air filter, only 3 particles are allowed to pass through. Thus, you get the 99.97% at .3 micron rating. If you were to use the HEPA test on a 95% ASHRAE air filter they would be about 50% efficient on .3 micron sized particles once they loaded up with dust. So, HEPA air filters are at least 50% more effective at removing respirable sized airborne particles than any of the ASHRAE air filters on the market.

### **Field Testing of Absolute Filter**

The Federal Standard 209 defines leak as a hole, which would produce a local penetration of 0.1% on photometer with an upstream concentration of 100%. The test is performed with an airflow sampling of 1 CFM across the filter at a face velocity of 90FPM.

- 1) Scan Testing: Standard testing of absolute filters use photometers and DOP techniques to measure efficiency and to scan for pinhole leaks. This test not only measures individual leaks but locates them as well. Typically, cold DOP smoke is used in the scan test, where every square inch of filter surface and its gaskets and framing system are scanned for



leaks using 1 CFM sampling rate @ 90 FPM face velocity. \*The term penetration indicates the amount of challenge aerosol, detected on the downstream side of a filter by a linear photometer, measured against the concentration of challenge aerosol on the upstream side of the filter. With a base of 100% for the upstream concentration, and a reading of 0.01% penetration on the downstream side, the indication is that the filter is 99.99% efficient with respect to that particular concentration.

- 2) Laser Testing: Laser based electronic particle spectrometers are capable of counting particles in very small discrete size ranges. Although valuable, this technique does not provide detailed information on specific particle sizes. What the particle counter can do is to give a reading of the number of particles per cubic-foot at any one point at one time. It doesn't indicate what the particles are, or where they come from.

The preferred test is the DOP test due to its accuracy and reset speed. The DOP tells the story right away-where the leaks are and how great. There are no time delays for readouts or probe recovery. The readouts relate to filter performance and not to an abstraction. The last applies to linear photometers only; log scale instruments give only relative results.

Note: it is not possible to use DOP with a particle counter because the concentration of aerosol is so high that the counter becomes saturated and jams, requiring a trip to the factory for repairs (except where expensive high volume samples with a diluting air source, are employed).

### **Filter Installation and Design Considerations**

HEPA & ULPA filters used in most stringent cleanrooms are generally built in the ceiling and can be installed in groups housed in a proprietary modular pressure plenum system. They can also be installed in single filter housings, individually ducted, suspended in an inverted "T" grid support system, and sealed to prevent unfiltered bypass air from entering the cleanroom. Cleanroom design conventionally follows the following guidelines for filter coverage.

ISO Class	Fed 208	Controls	HEPA Coverage as % of Ceiling
1	-	Stringent	100
2	-	Stringent	100
3	1	Stringent	100
4	10	Stringent	100
5	100	Stringent	100
6	1,000	Intermediate	33 - 40
7	10,000	Intermediate	10 - 15
8	100,000	Less Stringent	05 -10

Installing HEPA/ULPA filters directly in the ceiling of the cleanroom is driven by the desire to minimize, if not eliminate, dust-collecting surfaces, such as the inside of ductwork, between the downstream face of the filter and the cleanroom. Remote mounting of HEPA filters is common in Less Stringent applications since the number of particles that can be contributed by ductwork downstream of the HEPA filters is small as a proportion of the amount that can be tolerated. An exception would be where a standard air- conditioning system with no cleanliness classification is being upgraded to support a cleanroom intended to carry a cleanliness rating per Federal Standard 209 or ISO Standard 14644. In that case, all ductwork downstream of the filter should be thoroughly cleaned.

The average HEPA filter, properly installed, and with frequent changes of the prefilter, should last from five to eight years. There are always unusual cases: filter used to capture

hazardous particles or pathogenic organisms should, of course, be changed when they become unsafe for use. Otherwise, the resistance of the filter as indicated on a monometer or the air flow measured with a velometer is indications of need for a change.

### **Terminal Filters**

These filters are available in two types of constructions: (1) Box type and (2) Flanged type.

- 1) Box type filters are more suitable for housing within the ceiling slab cutout where removal of filter is from above. Whenever filter removal is not from above e.g. in case of filter being mounted in false ceiling, flanged type of filters is used.
- 2) With flanged type of filters, additional housing is also required to facilitate the mounting of filters and transfer the load to false ceiling members. These housings can also be provided with an alternate arrangement to transfer the filter load to ceiling slab.

Aluminum / stainless steel slotted type protective grilles can be provided under the terminal filters. The housing and grilles should be epoxy/stove enamel painted.

### **Face Velocity across HEPA/ULPA Filters**

The face velocity of ceiling mounted filters generally can be as high as 130 fpm and as low as 50 fpm depending on the design of the system. Since the system supporting the filters, such as the inverted "T" grid, may occupy as much as 20% of the ceiling area, a 100 fpm filter-face velocity translates into an 80 fpm average velocity at the work surface within the cleanroom. The typical ceiling mounted clean filter is designed for a pressure drop on the order of 0.5 inch w.c. at a face velocity of 100 fpm.

Cabinet fans or air handlers with HEPA filter racks on the discharge side are frequently used in Less Stringent applications. The HEPA filters used in these applications are generally high velocity filters, based on 500 fpm filter-face velocity, with a pressure drop significantly higher than those used in ceiling installation. A clean 2 ft x 2 ft high-velocity HEPA filter can have a 1.5 in-w.c. pressure drop at 500 fpm.

## Pre-filters to HEPA Filters

In order to prolong the service life of HEPA filters, pre-filters are recommended to filter out majority of particles above 1 micron. Pre-filters are normally mounted after supply air fan discharge in a separate plenum with an access door at an appropriate location. Normally flanged filters are used for mounting in such prefilter plenums.

It should be convenient to clean and replace these filters without disturbing the rest of the filtration system.

Pre-filters are available in various sizes with a 6" or 12" thickness and with pressure drop in the range of 0.2" to 0.25" w.c. However, dust holding capacity of these filters is poor. The applications which require a filtration system with good dust holding capacity, bag type filters with fiberglass scrim cloth media are recommended. These give efficiencies ranging from 85% (down to 20 microns) to 99.97% (down to 5 microns).

## AIRFLOW

Airflow is usually specified either as average air velocity within the room or as air changes per hour.

### Cleanroom Industry Design Thumb Rule

ISO Class	Fed 208	Controls	Air Velocity at table level in FPM	Air Changes Rate per Hour
1	-	Stringent	70 - 130	>750
2	-	Stringent	70 - 130	>750
3	1	Stringent	70 - 130	>750
4	10	Stringent	70 - 110	500 - 600
5	100	Stringent	70 - 90	150 - 400

ISO Class	Fed 208	Controls	Air Velocity at table level in FPM	Air Changes Rate per Hour
6	1,000	Intermediate	25 - 40	60 - 100
7	10,000	Intermediate	10 - 15	25 - 40
8	100,000	Less Stringent	3 - 5	10 - 15

\* Recommendations are not based on scientific findings and there is no clear consensus on an optimum ACR/ air velocity.

### Face velocity

The velocity of the air is often determined by the degree of contamination control we wish to achieve--as a general rule, cleaner rooms require more air velocity than rooms that are less clean. Supply air volume is also highest in Class 1, and decreases as the requirement for cleanliness decreases.

For years, a value of 90 fpm (0.46 m/s)  $\pm 20\%$  has been used to specify the airflow in the cleanest of cleanrooms. The primary objective is to maintain airflow in parallel flow streams that has two purposes: first, it needs to dilute particle concentrations that may have formed in the room due to personnel or process activity and second, to carry away particles or contaminants generated within the room. Although, higher air velocity is advantageous in particle removal/settlement, this will also result in over sizing of equipment that may be very energy inefficient.

### Set velocity of 90 FPM! Is it Mandatory Requirement?

There is nothing called set velocity; the 90 fpm velocity is just a widely accepted practice. There is no scientific or statutory basis for this guideline. The figure, 90 fpm velocity, is purely derived from past practices over two decades and became a common industry practice. In recent years, companies experimented with lower velocities and found that airflow velocity specifications ranging from 70 to 100 fpm (0.35 to 0.51 m/s)  $\pm 20\%$  could be successful, depending on the activities and equipment within the room. For example, in an empty room

with no obstructions to the airflow, the air velocities @70 FPM can remove contamination effectively. There is no single value of average velocity or air change rate accepted by the industry for a given clean-room classification. In general, the higher values are used in rooms with a greater level of personnel activity or particle-generating process equipment. The lower value is used in rooms with fewer, more sedentary, personnel and/or equipment with less particle-generating potential.

### **Airflow based on Air change rate (ACR)**

Air change rate is a measure of how quickly the air in an interior space is replaced by outside (or conditioned) air. For example, if the amount of air that enters and exits in one hour equals the total volume of the cleanroom, the space is said to undergo one air change per hour. Air flow rate is measured in appropriate units such as cubic feet per minute (CFM) and is given by

$$\text{Air flow rate} = \text{Air changes} \times \text{Volume of space} / 60$$

Air change rate is an indication of the air-tightness of a room, but it is difficult to pin down because it depends significantly on how the space is used, as well as the wind and temperature differentials it experiences during the year. Even if the rate is determined with some precision, which is established with a blower-door test, there is no assurance that value would apply under other conditions. The air change per hour criterion is most commonly used in cleanrooms of less stringent cleanliness. Intermediate cleanrooms are usually designed with hourly air change rates between 20 and 100, while less stringent cleanrooms have hourly air change rates up to 15. The designer selects a value based on his experience and understanding of the particle-generating potential of the process.

Higher ACR equate to higher airflows and more energy use. In most cleanrooms, human occupants are the primary source of contamination. Once a cleanroom is vacated, lower air changes per hour to maintain cleanliness are possible allowing for setback of the air handling systems. Variable speed drives (VSD) should be used on all recirculation air systems allowing for air flow adjustments to optimize airflow or account for filter loading. Where VSD are not already present, they can be added, if coupled with modest turndowns, and provide excellent payback. The benefits of optimized airflow rates are

- 1) Reduced Capital Costs - Lower air change rates result in smaller fans, which reduce both the initial investment and construction cost. A 20 percent decrease in ACR will enable close to a 50 percent reduction in fan size.
- 2) Reduced Energy Consumption - The energy savings opportunities are comparable to the potential fan size reductions. According to the fan affinity laws, the fan power is proportional to the cube of air changes rates or airflow. A reduction in the air change rate by 30% results in a power reduction of approximately 66%. A 50 percent reduction in flow will result in a reduction of power by approximately a factor of eight or 87.5 percent.

Designing a flexible system with variable air flow can achieve the objectives of optimized airflow rates. Existing systems should be adjusted to run at the lower end of the recommend ACR range through careful monitoring of impact on the cleanroom process (es).

### Air Flow Pattern

Airflow pattern have evolved into three major types:

- 1) Unidirectional flow (also referred to as “laminar flow”), where the air streamlines are essentially parallel to one another.
- 2) Non-unidirectional flow (also referred to as “turbulent flow”), where air streamlines are other than parallel to one another.
- 3) Mixed flow, where air streamlines may be parallel in one part of the cleanroom and not parallel in other parts.

Cleanroom Class	Airflow Type
1	Unidirectional
10	Unidirectional
100	Unidirectional

Cleanroom Class	Airflow Type
1,000	Non-Unidirectional
10,000	Non-Unidirectional
100,000	Non-Unidirectional

### **Unidirectional (Laminar) Airflow System Designs**

Stringent cleanrooms with classification rating 100 and below are almost invariably designed for unidirectional airflow. A Laminar airflow system contains three basic elements - a blower, a high efficiency air filter, and a plenum. There may be variations on this idea - many blowers, many filters, and very large plenums, but all have the same basics.

Typically, laminar flow is achieved by supplying air through HEPA/ULPA filters, ensuring 100% ceiling coverage. The air moves vertically downward laterally from the ceiling to a return air plenum on a raised floor. This approach allows the contamination generated by the process or surroundings to drift to the floor void. The particles are finally captured by the vacuum pump in the floor void or sucked back for recirculation through the HEPA filters in the ceiling.



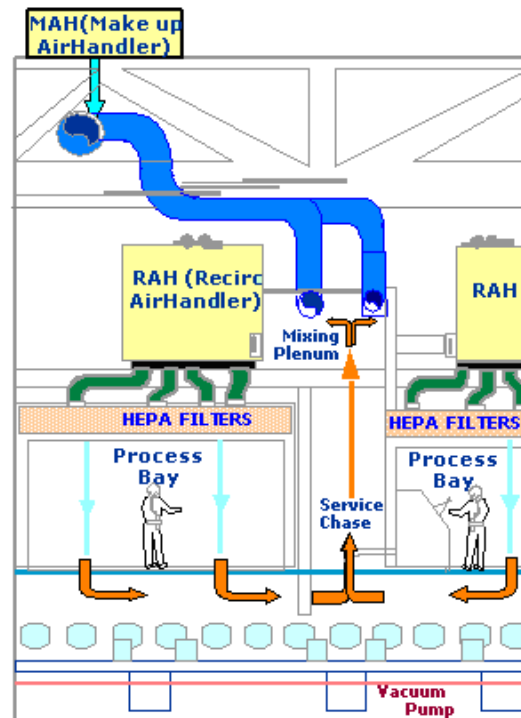

### Cleanroom Arrangements with Raised Floor Return

In the scheme above, the class-100 room is shown with 100% HEPA ceiling coverage. The make-up air handler (MAH) is a fresh air unit that provides the room pressurization and is designed for latent and sensible load of outside air. This unit feeds to two re-circulation air handlers (RAH) that supply air into the cleanroom. The RAH are usually designed primarily for the sensible heat load generated indoors from the process equipment and occupancy. The key characteristics of unidirectional air flow system are as follows:

1. Unidirectional airflow system is designed for an air velocity of 60 to 90 FPM. This air velocity is sufficient to keep the contaminants directed downwards and remove particles before they settle onto surfaces.
2. For wider rooms (>16ft), it is best to provide a raised floor return so that the airflow tends to remain parallel (or within 180 degrees of parallel to the walls). Where the clean space is fairly narrow, of the order of 14 to 16 ft (4.2 to 4.8 m) from wall to wall, the raised floor can be eliminated in favor of low sidewall return grilles. The air will move vertically downward to within 2 to 3 ft (0.6 to 0.9 m) of the floor before splitting and moving toward the sidewall returns.

3. Unidirectional (Laminar) airflow tends to become turbulent if it encounters obstacles such as people, process equipment and workbenches. Placing these obstructions in a manner that prevents dead air spaces from developing will minimize turbulence. Use of workstations with perforated tabletops will allow the air to pass through them uninterrupted. Equipment shall also be raised on a platform (plinth) where possible to allow free air flows beneath it.
4. In unidirectional arrangement, HEPA filter banks must be "pinhole" tight and checked for any pinhole leaks in the media, sealants, frame gaskets, and supporting frames.
5. In some designs, the supply air can be projected upwards from floor void and is drawn into a ceiling void. This arrangement is preferred in applications where the localized hardware or equipment has high heat dissipation. The conventional supply airflow from ceiling may not be directional enough to cool the equipment that results in hot spots.

### **Unidirectional Design Configurations**

The unidirectional design is typically available in one of the three major configurations: (1) Clean work stations, (2) Tunnel design and (3) Open bay design.

1. Clean Work Stations are used for localized areas and involve the use of hoods with HEPA filters. These find quite a use in laboratories and research centers. These offer energy efficient operation as only a small volume is provided with desired class cleanliness level rather than the whole area.
2. Tunnel Design incorporates HEPA filters in ceilings instead of hoods. Similar to clean work stations, this arrangement, provides localized cleanliness with the difference that the cleanroom space is partitioned from rest of the area and HEPA filters are mounted on ceiling. This arrangement is suitable for modular spaces typically between 11 and 14 feet wide. Wider tunnels experience too much or turbulent flow. The advantage of a tunnel is reduced HEPA filter coverage and ease of expanding additional tunnel modules into unaffiliated areas. The disadvantage is they restrict new equipment layouts as processes change, and products change.
3. Total Clean-Room (open bay design) strategy involves open bay designs that typically use HEPA filters in the entire ceiling and returns in the floor. The design is suitable for

large areas up to 50000 sq ft construction with interior walls placed wherever production processes dictate. These rooms are more costly to build and maintain but do provide flexibility for change as new products are introduced and production equipment or processes are improved.

### NON-UNIDIRECTIONAL AIRFLOW

This method is often used in intermediate cleanroom classification 1000 and above. Here, the air streamlines are random with no definable pattern.

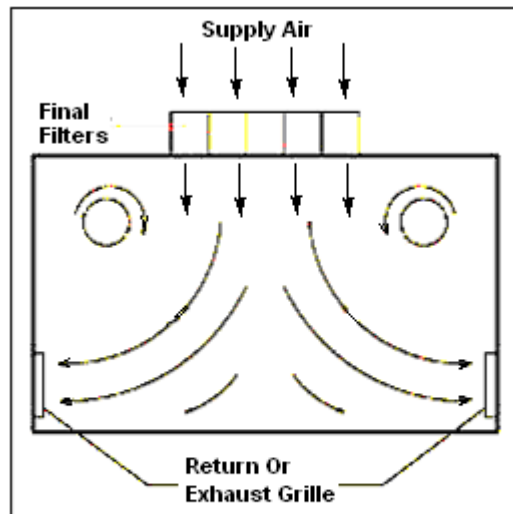

Conventional flow or non-unidirectional airflow pattern

The airflow is typically supplied through terminal HEPA diffusers installed in the ceiling in a pattern that provides fairly uniform coverage. The HEPA filters are sometimes installed straight in the ductwork or the air handler itself. The return is usually through the sidewall grilles uniformly distributed around the periphery of the room.

It is good practice to limit the horizontal distance air must travel to a return outlet to 14 to 16 ft. Therefore, a room 28 to 32 ft wide only needs return grilles located in the peripheral walls. For wider rooms, it is common practice to box in support columns and incorporate return grilles and return air ductwork within the box.

A shortcoming of non-unidirectional cleanrooms is pockets of air with high particle counts. These pockets can persist for a period of time, and then disappear. (This is due to currents

that are set up within the room due to process related activity combined with the random nature of the downward airflow.) Sidewall return arrangement can pose a challenge when process equipment is intended to occupy wall space. When possible, the equipment should be moved off the wall to permit air to flow behind it.

### MIXED FLOW APPROACH

The mixed-flow approach is used where critical and non-critical processes are in the same clean space. Zones are created by adjusting the filter pattern in the ceiling; in a stringent area, more filters are installed in the ceiling and in less critical areas, fewer filters are installed. Supply air may have to be canalized downward over the critical zone before it diffuses to the general space. Depending on clean-room ceiling height, a 2 ft high Plexiglas shield, or even a flexible plastic curtain draped to within 12 to 18 in of the floor, can be used, to separate different zones of cleanliness.

Return air patterns are adjusted by appropriately locating return grilles to accommodate the varying filtered air quantities and to prevent cross contamination. A raised floor with air return plenum would be more effective.

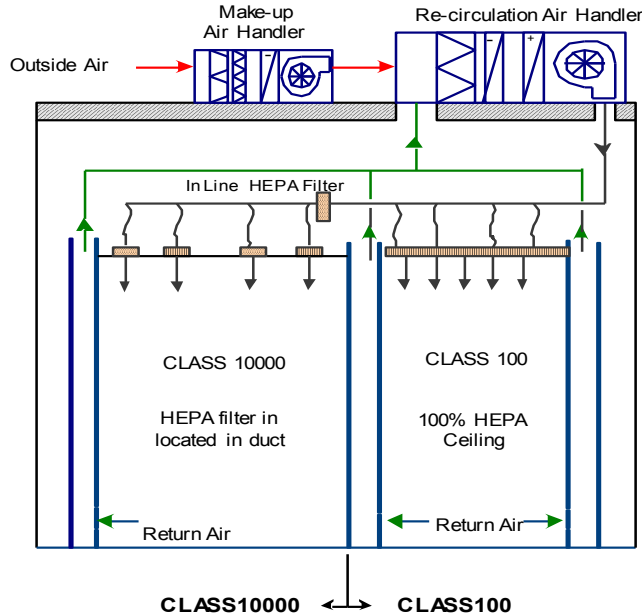

## **POSITIVE PRESSURIZATION AND VENTILATION**

Positive pressurization of the sensitive areas is an effective means of controlling contaminant infiltration through any minor breaches in the room perimeter. Positive pressurization is achieved through supplying more outside air than what is exhausted from the space. It is, however, extremely important that air introduced for pressurization is adequately filtered and conditioned.

### **Pressurizing Limits**

Positive air pressure means the cleanroom is "pumped up" with more filtered air than the surrounding space outside the cleanroom(s). Generally, a value of 0.05 inch w.c. (12 Pa) pressure for the clean space relative to unrated areas is recommended. In clean spaces with multiple rooms, the most sensitive areas should be the most highly pressurized. The trend is to maintain a positive pressure of 0.02 inch w.c (5 Pa) between adjacent clean spaces of differing ratings, with the higher pressure in the space at the higher cleanliness rating. This ensures that the air does not transfer from a less clean space to stringent clean room. The only exception to using a positive differential pressure is when dealing with specific hazardous materials where the statutory health and safety agencies require the room to be at a negative pressure.

### **Optimizing Makeup Air Requirements**

Only a minimal amount of air should be introduced into the controlled environment. Makeup air is very expensive because it must be tempered, humidity adjusted, and cleaned before being introduced into the cleanroom. Careful attention needs to be paid NOT to over-pressurize the area. With higher pressurization the leakage velocity, leakage rates and the processing costs shall also increase. While makeup air is unavoidable, it should be minimized to the extent possible in the interest of energy conservation.

Positive pressurization can be maintained only if the sealing integrity of the building is maintained. The building should be air tight for low air leakage performance. There are areas within the facility that require negative exhausts such as toilets, pantry, laboratory or battery room but these are controlled ventilation areas having fixed amount of exhaust. Uncontrolled leakage areas in the building are door undercuts; pass through, walls, ceilings and duct joints etc., and should be restricted as far as possible.

As a rule of thumb, the quantity of makeup air can be determined by summing all the process exhaust volumes in the space then adding two additional air changes per hour. This semi-empirically derived value has proven to be a safe quantity to use to size the makeup air handler. Actual makeup air introduced at any one time will vary depending on door openings, leakage, and actual exhaust in operation. This provides assurance that carbon dioxide and oxygen remain in balance and that formaldehyde and other vapors given off by building materials, paints, and furniture, etc. are diluted, and that air changes occur with sufficient frequency to minimize the chance for high concentration of airborne pollutants within the building.

### **Impact on Energy Use**

Over pressurization is waste of energy that not only entails high capital costs but also increases the operating costs. Let's see one example.

One-inch water gauge pressure is equivalent to wind velocity of 4005 feet per minute (~45 miles/hr).

High pressurization will result in higher leakage rates. The amount of expected leakage can be calculated from the following equation:

$$\text{Leakage Velocity (fpm)} = (\text{Room pressure in inch-w.c.})^{1/2} \times 4005$$

$$\text{Leakage rate} = \text{Opening Area (sq-ft)} \times \text{leakage velocity (fpm)}$$

#### Case-1: Assuming 0.05" w.c. positive pressurization

$$\text{Leakage Velocity} = (0.05)^{1/2} \times 4005$$

$$= 0.223 \times 4005$$

$$= 895 \text{ fpm}$$

With a total of 2 square feet opening

$$\text{Leakage Rate} = 2 \times 895 = \text{say } 1800 \text{ CFM}$$

#### Case-2: Assume 0.1" w.c. positive pressurization

$$\begin{aligned}\text{Leakage Velocity} &= (0.1)^{1/2} \times 4005 \\ &= 0.316 \times 4005 \\ &= 1265 \text{ fpm}\end{aligned}$$

With a total of 2 square feet opening

$$\text{Leakage Rate} = 2 \times 1265 = 2530 \text{ CFM [This is 40\% increase in leakage rate.]}$$

Now let's see the impact on energy costs.

For the same example above, assume, the outside makeup air is at 95°F DB/72°F WB which needs to be conditioned to 72°F DB/60°F WB. From the psychrometric charts, the enthalpy difference (heat to be removed to bring outside air to cleanroom conditions) is 9.5 BTU/lb of air.

The heat load is given by equation:

$$Q \text{ (Btu/hr)} = 4.5 \times \text{airflow in CFM} \times \text{enthalpy difference}$$

For case-1: 1800 CFM leakage

$$Q = 1800 \times 9.5 \times 4.5 = 76950 \text{ BTU's/hr}$$

This is equivalent to 6.4 TR\* [\*Note 1 ton of refrigeration (1 TR) is equivalent to heat removal rate of 12000 BTU's/hr]

For case-2: 2530 CFM leakage

$$Q = 2530 \times 9.5 \times 4.5 = 108234 \text{ BTU's/hr or}$$

This is equivalent to 9.0 TR

Therefore the client will incur an extra capital cost equivalent to  $9 - 6.4 = 2.6$  TR. Not only the capital cost, higher pressurization (case-2) will incur recurring higher energy costs of nearly 4 kWh [@ 1.5 kWh per TR of cooling load], which translates to 35000kWh per annum on 24/7 operations.

The room pressure should be limited to 0.03 to 0.05 inch-w.c.

### AIR DISTRIBUTION STRATEGIES

Numerous air-management concepts were devised over the years to supply and re-circulate air in cleanrooms. Two common design strategies for an air handling system are (1) Single Pass System or Once Thru System and (2) Re-circulated System. The choice depends on number of factors such as; the type of product being handled, the process operation, the process equipment design, toxicity of the product being produced and impact on energy use.

#### Once-thru Air System

Filtered air enters the room and is not re-circulated. All the air is exhausted outdoors. The system is used for cleanroom processes demanding 100% makeup air or when ambient temperatures are favorable. As an example, when the potential of releasing dust or aerosolized materials exists, “once-through” HVAC system is recommended.

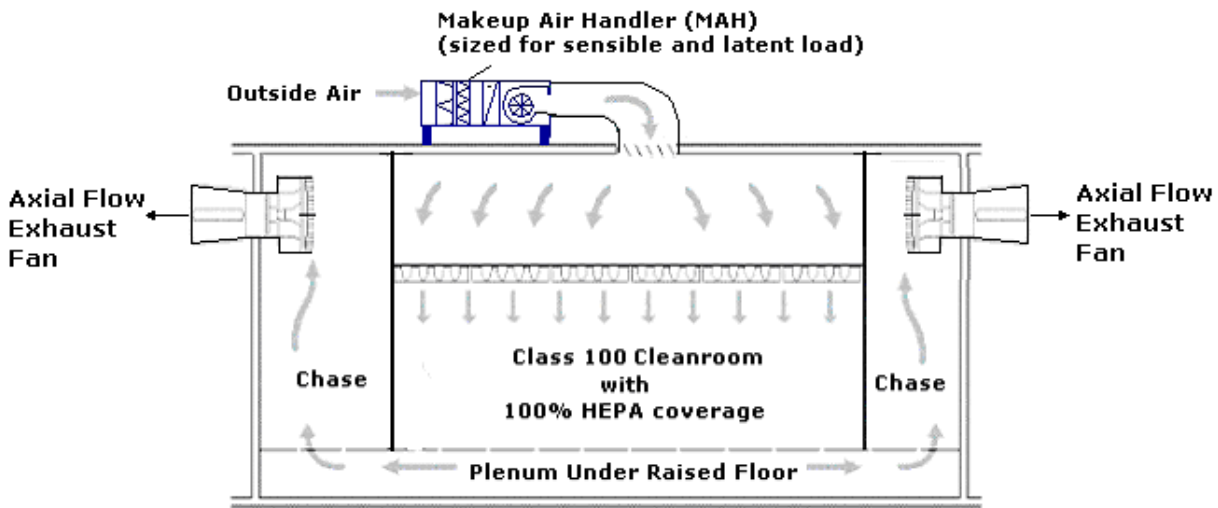

Once-thru Air Handling System

#### Recirculation Air System Types

Re-circulated systems are the most popular design for the reasons of economy of scale, size and energy conservation.



Filtered air enters the room, exits through plenum walls and is re-circulated through a sealed plenum using motorized fan modules with HEPA filters. There are two fundamental recirculation system configurations: (1) Centralized recirculation air-handling units (RAHs) and (2) Ceiling distributed fan-filter units (FFU). The selection of the system configuration is usually dictated by building configuration, initial investment cost, and constructability.

### 1) Centralized Re-circulating Air Handling Units (RAHs)

The centralized air-handling system typically uses custom rooftop or package air handlers for makeup air. The makeup air handler (MAH) supplies pre-filtered air for pressurization adequately treated for both sensible and latent loads. The outside air is forced into a pressurized plenum which also draws re-circulation air from indoor spaces. The pressurized plenum ceiling is provided with HEPA filtration ceiling to distribute air in unidirectional path. The schematic below depicts a standard cleanroom module using a conventional vane-axial fan distributing air into pressurized plenum.

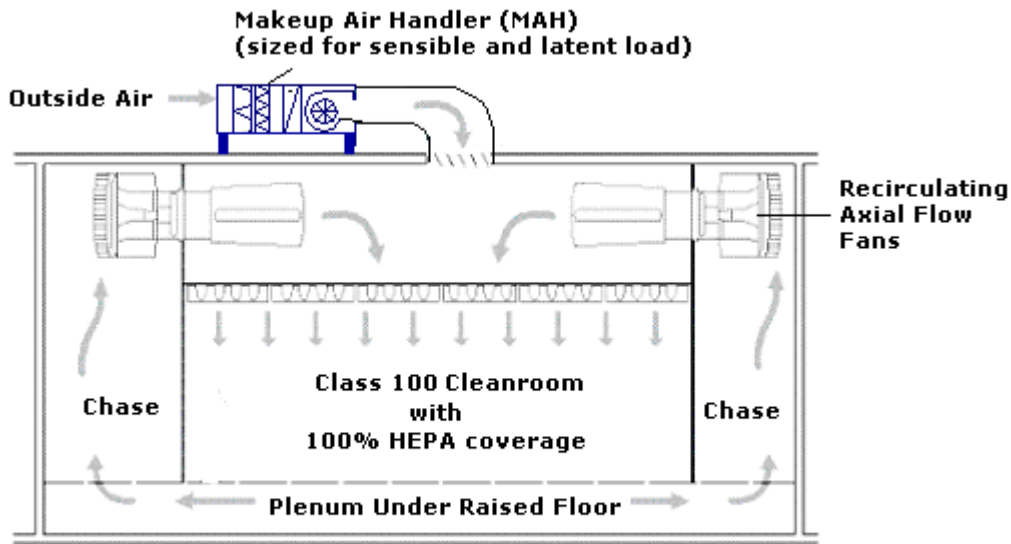

**Recirculating Air Handling System**

There are many possible variants of the recirculation air system. In the arrangement above, the re-circulated air is not further treated or conditioned (for temperature, humidity or dust control). Simply the large volume of indoor air is re-circulated by axial fans through the ceiling HEPA filters.

If the indoor process generates significant dust and temperature rise, it is recommended to use re-circulation package air-handler (RAH) units instead. The re-circulating air handlers consist of centrifugal fans and have an additional provision of sensible cooling coil and pre-filters to minimize dust loading of ceiling HEPA filters.

Both vane-axial fans and centrifugal fans are used.

- Vane-axial fans offer the advantage that they can efficiently move large volumes of air against comparatively low static pressure. This is typically the set of conditions under which any cleanroom recirculation fan must operate. Vane-axial fans are relatively compact and fairly inexpensive. A disadvantage of these fans is that a large part of the total pressure generated is velocity pressure. This becomes a significant factor in the selection of the fan. Vane-axial fans are noisier and need extensive sound attenuation measures.
- The centrifugal fans can develop as much static pressure as is needed to move the air through the various components of the recirculation loop. However, as the total airflow increases, so does the fan size, the fan cost, and the amount of noise that the fan generates. Therefore, multiple, smaller air-handling units, installed in parallel, typically are used.

## 2) Ceiling Distributed Fan-filter units

Fan-filter units typically consist of a centrifugal plug fan driven by a fractional horsepower motor, controller and a HEPA/ULPA filter enclosed in a box, which fit into common cleanroom ceiling grids, typically 2 x 4 ft or 4 x 4 ft.

The air is supplied to the room via terminal fan filter units using "spider leg" ducting. Each branch leg of spider ducting is connected to the fan filter neck and the units are simply gasketed in the ceiling. These are generally not used in pressurized plenum arrangement, which requires a gel-track ceiling.

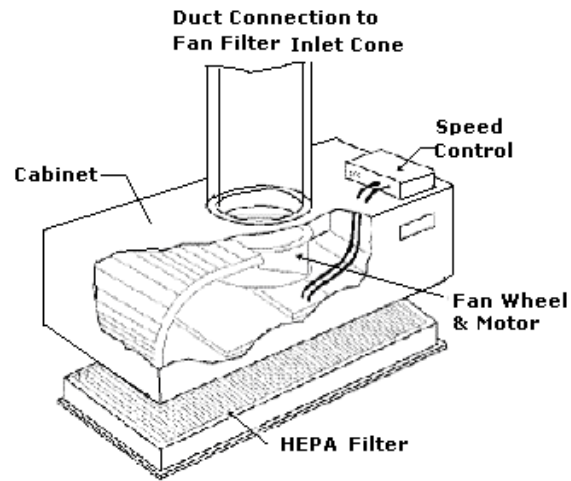

Fan Filter Unit

The FFU system design has the following characteristics:

1. Small fans force air through filters. The units often have adjustable speed control and typically have full speed energy consumption of 190 – 250 watts. The newer installations use more efficient DC motors.
2. The main advantage of FFU system is simplicity and these systems are very popular in mini-environment cleanrooms. However, the FFU puts out a quantum amount of flow in a 2'x4' ceiling space. Flow rate and velocity are not independent variables and therefore these do not lend itself to efficient design for proper airflow distribution.
3. Fan-filter units are quite expensive. Even though the unit cost of a fan-filter unit is low, a typical cleanroom module will require many such units; and the total cost quickly exceeds that of centralized RAH system.
4. The fan-filter units require larger air passageways in order to reduce static pressure losses. This increases both the overall building width and height.
5. Fan-filter units can be set in a gasketed ceiling. Other options will generally have pressurized supply plenums, which require a gel-track ceiling.
6. The electrical distribution cost is highest for fan-filter units. Even though the motors are much smaller, there are many more of them. Also, the automation costs are higher for fan-filter units, again due to the large quantity of fans.

7. Ceiling distributed fan-filter units do not develop much static pressure and therefore either custom air-handlers or booster fans are often required in conjunction with the FFUs. The system does not lend it self to double HEPA filtration.
8. The noise level from a typical FFU is low at 53dba @ 90 FPM face velocity. However, the use of multiple fans (in some cases hundreds of them) can result in significant noise level being radiated into the cleanroom.
9. The use of multiple fans necessitates use of electronic monitoring system to check the status of each motor.

## **DUCT SYSTEM DESIGN AND CONSTRUCTION**

Aluminum or Stainless Steel (SS304) ducting is generally provided to supply air to the cleanroom and to bring back air from the return air grilles to the return air fan. Following precautions should be taken while designing and fabricating the duct system:

1. Ducts should be sealed with silicone sealant at longitudinal joints in order to make the system airtight. Ventilation ducting in SS-304 material with plasma welding for leak tightness is preferred.
2. Rubber gaskets should be used at transverse joints.
3. Flanged joints must be avoided and instead pocket slips or angle iron flanged joints should be used.
4. No acoustic insulation should be provided inside the ducts.
5. Dampers provided in the system should be of Aluminum and should have extended handle to accommodate insulation thickness.
6. In order to carry particulate matter along with return air, return air risers should be designed for velocities not exceeding 1800 fpm and with a minimum velocity of 1200 fpm at the highest point. However, the inlet velocity at the return grille should be in the range of 300 to 400 fpm gradually increasing the same to 1200 to 1800 fpm.

7. Return air grilles should be Aluminum, stainless steel or stove enamel/epoxy painted construction.
8. Provision should be left in each return air riser for periodic cleaning. Today, duct cleaning equipment is available for this purpose.
9. Whenever terminal filters are mounted in the false ceiling, properly sealed access doors should be provided to reach the dampers above each filter.
10. Return air grilles should be located low near the floor and made as long as possible to increase the collection of dust particles over a larger area.
11. While locating the return grille, care should be taken to avoid placing the grille near a door opening into an adjoining lower pressure room. This is done to prevent creation of a low pressure zone near the door, thus preventing air leakage from the low pressure to high pressure room at the time of door opening.
12. To cater for the proper supply air quantity, balancing dampers should be installed at critical points. Opposed blade dampers should be provided above each HEPA filter in order to properly balance the air distribution system.

## **INDOOR CONDITIONS**

Cleanrooms temperature and humidity requirements should be defined and addressed at the early stages of the conceptualization phase. Each cleanroom design strategy is unique to the project and should be analyzed carefully to confirm the nature of the cooling load.

## **TEMPERATURE RECOMMENDATIONS**

For cleanrooms, the temperature set point for comfort is usually 68°F or less depending on the required level of gowning for the personnel working in the process area.

In a single pass system, utilizing large amount of outside makeup air, both sensible load (due to outside air temperature) and latent load (due to moisture) must be conditioned before it enters the recirculation air-handler. Preheating is commonly provided where the outside temperature falls below 40°F (4°C) in winter.

For recirculation units, the majority of cooling load is attributed to the heat release from process equipment and therefore in most cases, cooling load sensible heat ratio\* exceeds 95%. The small latent load is generated by personnel.

\* Sensible heat ratio in % =  $\text{Sensible heat} \times 100 / (\text{Sensible heat} + \text{Latent heat})$

### Temperature Control Strategy for Stringent Cleanrooms

In stringent cleanrooms, not the entire volume of supply air is conditioned. A small percentage of the total airflow is drawn off from the return air stream by recirculating air handler (RAH) and is conditioned using sensible cooling coils. The outside air needed for pressurization is treated for sensible and latent load by makeup air handler. It is mixed with the recirculated air and is discharged back into the cleanroom return chase.

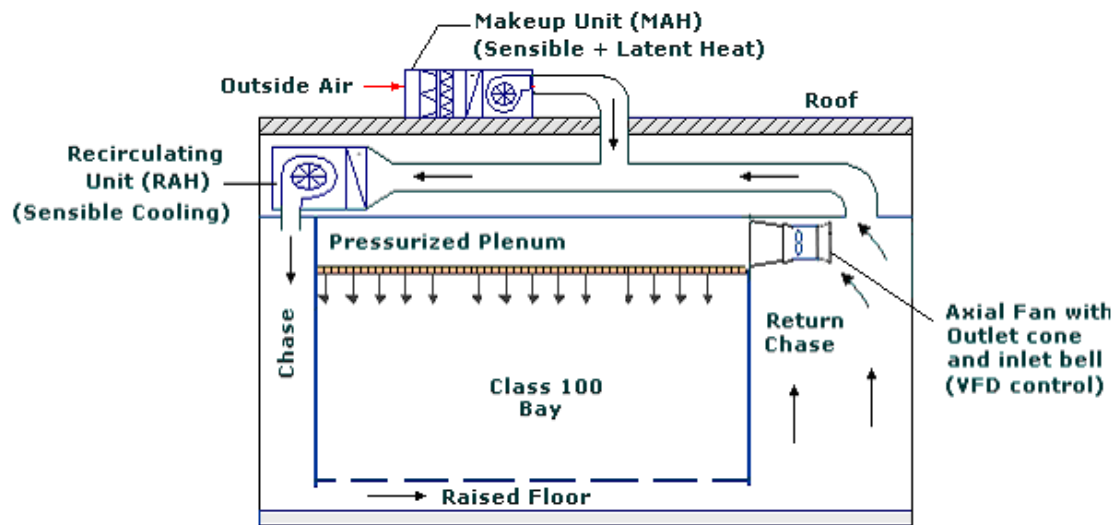

### Temperature Control Strategy for Less Stringent Cleanrooms

In less stringent cleanrooms (class 1000 and above), the total airflow may be close to that required for a normal cooling application. There may be NO recirculating fans at all but rather the air-handler or multiple air handlers, condition and recirculate “all” the air needed by the cleanroom.

Mixing dampers proportion the volume of each airstream in response to clean-room pressure. As clean-room pressure falls, the outside air damper opens and the recirculation air damper throttles to close position. The air temperature entering the room may be 15°F to 20°F (8.3°C

to 11°C) colder than the return air and the system design may incorporate standard ceiling diffusers to minimize uncomfortable drafts.

## **RELATIVE HUMIDITY RECOMMENDATIONS**

Relative humidity is the amount of moisture in a given sample of air at a given temperature in relation to the maximum amount of moisture that a sample could contain at the same temperature.

Ambient relative humidity levels between 45% and 50% RH would work with most products and provide a comfortable working environment. Under certain circumstances, most cleanroom equipment can operate within a fairly wide environmental range (20% to 70% RH), but the optimal goal should be specified at 45% to 50% RH for several reasons.

- 1) If the RH is too low, space relative humidity (RH) affects personnel particulate shedding (skin flakes), and when too high promotes the growth of toxic molds and other forms of biological contaminants.
- 2) High RH levels will accelerate corrosivity. The corrosion of electronic circuits and semiconductors is more pronounced at higher humidity levels.
- 3) High RH could be detrimental to hygroscopic powder materials, which are sensitive to high moisture content. Pharmaceutical industries use a lot of hygroscopic powder and chemicals in buffer and media preparation.
- 4) Low RH results in static electricity concerns. Electrostatic discharge (ESD) is easily generated and less easily dissipated in areas where the relative humidity is below 35% RH, and becomes critical when levels drop below 30% RH.

The 5% RH range may seem unreasonably tight compared to conventional air-conditioned systems, but it is not so difficult to maintain in a cleanroom because of the high efficiency vapor barrier, positive pressurization and zero infiltration. The HVAC system should have the capability of providing both humidification and dehumidification when working to closed tolerances of 5%.

## **Dehumidification**

Dehumidification is typically accomplished by cooling air below dew point. The cooling coil in the air-handling system must be deep to improve the extraction rate. Also the face velocity across the cooling coil should be limited to 400 fpm to maximize air contact with cooling coil surface and reducing by-pass across the coil. Reheating is required to raise the low temperature coming off the cooling coil after dehumidification. The thermostat controlling the reheat coil should be located within any areas having critical process operations and temperature requirements.

If the process operation requires a higher level of dehumidification (typically RH levels less than 40%) that cannot be attained with cooling coil dehumidification alone, then a desiccant based dehumidifier could also be considered.

## **Humidification**

For general area humidification, a steam humidifier installed at the AHU is recommended. The humidifier shall have multiple setpoints for variable steam rates. Selecting an appropriate location is important for maintaining the design setpoint. If humidification control for a specific zone (processing area) is required, then a duct-mounted humidifier should be used to maintain that space humidity requirement.

To maintain RH for process areas served by an AHU, the RH sensor can be located in the supply main or return main of the AHU. But for individual space RH control, the sensor should be located in the space or the common return/ exhaust duct serving that space.

## **Optimizing Temperature and Relative Humidity Limits**

The cleanroom processes require closer temperature and humidity tolerances sometimes as low as  $\pm 0.5^\circ \text{F}$ ,  $\pm 2\% \text{RH}$ . In the majority of cases the cooling equipment is also used to dehumidify. The humidity control is achieved by chilling mixed air down below dewpoint in deep DX or chilled water coil ( $40^\circ\text{F}$  entering water temperature) and adding reheat. When critical control is required the humidity control takes precedence over the temperature control implying that the cooling coil shall operate at full capacity even if the temperature drops below the set point. Temperature is again raised to the set point by employing reheat. This approach provides a reliable control approach but at great energy cost as the energy is first



used to sub cool and than to reheat to the set point. If the make up air heat gain is high, the reheat cost will be significant. An energy efficient solution to this shall be to employ two cooling coils.

- The first shall be provided in the make up AHU for taking care of sensible and dehumidification load of outside air.
- The second coil shall be designed for the sensible heat load of the process equipment.

The majority of the latent (moisture) load is because of the large quantities of outside make up air, which is fairly constant. The indoor latent load is insignificant and is largely the sensible load from the process machinery.

The scheme shall allow the second coil in the re-circulation unit to operate in partial capacity as soon as the temperature set point is achieved. The reliance on reheat shall be considerably reduced.

## **CONTINUOUS MONITORING AND BUILDING AUTOMATION SYSTEMS**

Accurate and comprehensive monitoring of environmental support equipment and in-room conditions is extremely important in a cleanroom environment. The monitoring system used must effectively assess the room conditions, or it will provide an inaccurate representation that can lead to inappropriate actions or ill-founded assumptions. The following considerations should be addressed

- 1) The facility's building automation system (BAS) requires the ability to monitor and control the set points as determined by the design team and documented in the project basis of design.
- 2) Temperature, humidity sensors, filter monitoring differential switches, dust particle counters must provide a detailed and representative profile of room conditions. For example, if a single point of reference is used, it will not give an accurate picture of the room's profile. If a single sensor is placed in an area with appropriate conditions, such as on a column directly above a perforated tile, the monitoring system would be indicating that room conditions are appropriate even though this may not be the case.

- 3) The BAS must be capable of indicating and recording alerts and alarms when the critical processing temperature/humidity/pressurization is not to specification. At the very least, the system should be set to notify appropriate personnel when conditions move outside certain parameters.
- 4) The system should have historical trend capabilities. The data gleaned from analysis of historical psychrometric information can be instrumental in determining seasonal changes or other outside influences.
- 5) The system should include a sequential particle counter for stringent cleanrooms, which can continuously monitor the cleanliness of the room.
- 6) The system configuration and data should be periodically examined and evaluated by trained personnel to ensure that they are appropriate for the current room demands, and to identify any problems missed in the day-to-day operations of the room.
- 7) The cleanroom should include automatic smoke detection units, fire protection (extinguishing system) involving "INERGEN" gas cylinders (combination of nitrogen, argon and CO<sub>2</sub> gases) for quick extinguishing of fire, and remote switches for switching off the blower in case of fire emergencies.

An integrated building monitoring system should be used to track conditions in all of the building systems. This would include not only the in-room air conditioners and humidifiers, but also the cooling support systems, power back-up, fire detection and suppression, water detection, security and other building infrastructure and life-safety systems.

## **ENERGY CONSERVATION**

Cleanrooms are highly energy intensive to operate. Because the air volumes supplied to the cleanrooms are many times (10-100) greater than those supplied to conventionally ventilated rooms, the capital and operating costs for the construction of cleanrooms can be very high. Cleanrooms present large opportunities for saving energy, a majority of which can result from mainstream HVAC system design concepts. Best practices for energy conservation include:

### 1) Right Classification of Cleanroom

Before any methods of contamination control can be applied, a decision must be made as to how critical particulate matter is to the process or product. This is done by classification of the room to requisite class level. For instance, it is not prudent to design the whole building to Class 100 when significant proportion of the building could be classified as Class 10000 or, in other words, a less critical area must not be provided with high-class classification just for conservatism. The process specialist should identify and segregate the critical and non-critical areas judiciously based on the requirements and manufacturer's recommendations.

### 2) Using Mini-environments where possible

Capture savings by creating mini cleanroom environments within large areas. In planning a cleanroom facility, zones of cleaner air can be established by concentrating HEPA filters in a particular ceiling area. Rather than providing a full filtered ceiling, create class 100 within class 10000 areas.

### 3) Challenge the room volume

Seek opportunities to evaluate whether conditions permit to minimize cleanroom volume: Doing this reduces re-circulation airflow requirements and the associated energy usage.

### 4) Optimizing Air change rates

Air change rate is the greatest determinant in recirculation air handling system fan and motor sizing. For ISO 5 (class 100) cleanrooms, 250 to 700 air change rate per hour are recommended. Benchmarking studies show that most facilities operate effectively at or below the low end of this range.

Reducing air change rate yields energy savings (e.g. a 30% reduction in ACR reduces power consumption by 66%) and may improve cleanliness by minimizing turbulence. Reducing ACR also may allow the downsizing of fans, motors, etc. and corresponding first costs.

Recirculation airflow can be controlled in various ways:

- System pressurization is an important factor in implementing an airflow reduction strategy. Reduce positive pressurization, when it is unlikely that particles will be generated.
- Use timers or scheduling software to lower airflow at certain times when the cleanroom is with minimal process activity.
- Use occupancy sensors to lower airflow whenever people are not present in the cleanroom.
- Use particle counters to control airflow in the room based upon real-time cleanliness monitoring. An output signal from the particle counters can directly control recirculation fan speed.

## 5) Optimal Equipment Sizing

The fan energy is proportional to the volume of air and the total static pressure used.

- Most engineers size air handlers with a “rule of thumb” of 500 fpm. This saves time, but increases cost of ownership. Pressure drop in a duct or air handler is approximately proportional to the face velocity squared. Fan power requirement decreases approximately as the velocity decrease. To reduce the pressure drop, specify a low face velocity unit in the 250 to 450 fpm range.
- Fan power is proportional to the cube of airflow rate or fan speed. A reduction in the supply air volume by 10% will result in a power reduction of approximately 27%. Providing the flexibility of speed control for the unit may help to improve energy efficiency of the units in operation.
- Utilizing variable frequency drives (VFDs) to realize operational savings from oversized fans, pumps, cooling towers and some types of chillers. Variable-speed drives use 15-30% less energy than constant-speed drives.
- Size the equipment to avoid efficiency penalties at part load conditions. Often this will involve unequal unit sizing and/or modular approach.

## 6) Optimizing Air distribution and Reducing Pressure Drop

Fan energy use is directly proportional to the pressure drop that the fan is pushing air through. Thus, the more restrictive the supply system, the higher the pressure drop, and the higher the fan energy use. Carefully evaluate the air distribution system. The major energy savings can accrue from the air distribution. Strategies for lower pressure drop include:

- Minimize obstructions to air flow, run straight duct lengths and avoid arbitrary zigzags. Pressure drop in ductwork *is inversely proportional to the fifth power* of duct diameter for e.g. substituting a 16 inch duct for a 12 inch duct reduces pressure drop by about 75%.
- Select cooling coils, sound attenuators and filters with low air pressure drop
- Keep low face velocity
- Select high efficiency filters. Higher-performance air filters clean supply air more efficiently, resulting in a reduction of energy consumption.
- Avoid excessive safety margins

Low pressure designs are applicable to all fan systems (e.g. recirculation, makeup and exhaust units). In addition to significant ongoing energy savings, low pressure drop systems enable downsizing of fan motors, less noise, more effective dehumidification, better filter effectiveness, and in some cases lower total first cost (when avoided electrical and noise abatement equipment is included in the cost analysis).

## 7) Right Equipment Location

- Fan motor location must be considered in terms of energy efficiency. Many typical modular systems utilize a large number of fractional horsepower direct drive motors at the terminal ends, which operate in the airstreams. These are usually single-phase motors, which have high power factor but low efficiency. Because of their location, they impart heat to the airstreams. Location of motors outside the airstreams not only limits heat gain but allows greater service access as well.

- Locating portions of process equipment in chase ways, with clean access on the room side, can decrease floor space requirements as well as lessening heat gain and exhaust needs.

#### 9) **Optimizing Outside Air**

The greatest single HVAC load in a typical cleanroom is the heat load from outside air. A large amount of outside air is needed for makeup exhaust losses and leakages and for clean zone pressurization requirements. Challenge exhaust air requirements and limit it no greater than 4 cfm/ft<sup>2</sup>. Make-up air could be 125% of exhaust air requirements for pressurization (i.e. 5 cfm/ft<sup>2</sup>) Build tight and ventilate right should be the design principle.

#### 11) **Selecting High Efficiency Equipment**

- Specifying high efficiency components, including high efficiency motors and fans, chillers and other equipment
- Screw and centrifugal compressors enhance chiller reliability. Modern centrifugal chillers consume as little as 0.60 kW per ton of refrigeration and machines equipped with the variable-speed technology yield greater energy savings for a faster payback.
- Chiller work is proportional to the vapor pressure work of the compressor – this work is lowered if chilled water temperatures are raised and/or condenser water temperatures are lowered. The majority of cleanroom chilled water requirements are best served by a medium temperature of 55 to 70°F chilled water.
- Consider the chillers with high energy efficiency ratio. Centrifugal chillers offer efficiency as high as 0.60 kW/ton

#### 12) **Choosing Right Configuration of Equipment**

Consider separate make up and re-circulation AHU units. Provide re-circulation AHUs with sensible conditioning apparatus and make-up AHUs with sensible and dehumidifying coils

### 13) Challenge design

Challenge design, if the following exceeds the limits:

- Static pressure of 4" w.c. on makeup air units
- Static pressure of 2" w.c. on re-circulation air units

Challenge design if:

- Fan efficiency is lower than 85%
- Fan motor efficiency is lower than 94%

Not unexpectedly, airflow design emerges as the key element in any strategy to capture savings in cleanrooms. It's here that the most significant savings in energy consumption can be realized.

## DEVELOPMENTS IN CLEANROOM TECHNOLOGY

There have been a series of major technological developments in construction materials, cleanroom fittings and subsystems for the new generation of cleanrooms that are being presently built. Some salient advances are worth mentioning.

### 1) Advancements in Filter Technology

- HEPA filters are fabricated with sub-micron glass fiber filter media formed into a high density paper in an extruded, anodized aluminum casing ( or a medium density fiber board casing), fire retardant, and with knife edge type in mini-pleat separator less construction.
- ULPA filters available in the market today are boron free, 99.9997% efficiency for particles down to 0.12 micron size, for Class 10 cleanrooms, in anodized aluminum casing and mini-pleat separator less construction.

## 2) Advancements in Air distribution Equipment

- Air handling units are of double skin type in SS-304 construction or GI powder coated construction. These can be very silent in operation and are built with pre-insulated PU foam between the outer sheath and the inner sheath. These air handling units can be directly installed on the roof with ducting connected to it at the outlet and the inlet. This eliminates the need for a separate plant room or AHU room.
- Fan Filter Units are widely available for mini-environments in smaller modules with DC motor driven built-in fans with an integral filter section, and can be directly fitted in the ceiling grid at the required location. Where a better class of cleanliness is required for a small area within a cleanroom, these modules are being used, which are economical and fast to build.

## 3) Use of DC drive for Fans

Today fan-filter units are available with a brushless, electronically commutated DC motor with an external rotor. A Hall-effect sensor is used to detect the position of the rotor magnet each time it rotates. Control circuitry then precisely adjusts the motor voltage to match the torque requirement of the fan, thereby minimizing inefficiencies due to slip. Overall, the resultant motor efficiency is 75 – 80%, compared to less than 40% for phased split capacitor or shaded pole motor designs. With this improved efficiency comes the byproduct of quieter operation. Because the fan uses a DC motor, its speed is infinitely variable. The controller can be set up so the rotational speed of the fan is remotely monitored and controlled. The on-off status of each fan-filter unit also can be remotely controlled and monitored.

## 4) Improvements in Fan Design

Vane-axial fan packages are now available that combine advanced fan engineering with aerodynamically and acoustically engineered sound attenuators. This type of package can be applied to recirculation air handlers yielding a quiet and efficient system. If needed, vane-axial fans can be selected with additional static pressure capacity to accommodate such items as prefilters or chemical filters. Fan-filter units generally do not have this capability.



## 5) Air-Lock Strategies to Prevent Cross-Contamination

Those entering a high-level cleanroom are required to pass through an airlock. An airlock is used to create a barrier between the cleanroom where the process resides and the adjacent area. Or simply, it protects clean areas from adjacent areas with a lower required cleanliness. In general, there are three basic airlock designs that can be combined or used individually to protect the cleanroom and/or prevent cross contamination between two adjacent areas of different process operations and served by two different HVAC systems. These three airlock systems are (1) the cascading pressure airlock, (2) the pressure bubble and (3) the pressure sink.

- The cascading pressure airlock - Normally, in this type of airlock, the transfer from the cleaner area, which does not pose any issue with cross contamination, is pushed into an adjacent area or access hallway.
- The pressure bubble airlock - This type of airlock is a positively pressurized space that pushes the air "OUT" and into both the areas it protects thus creating a barrier between the two spaces it serves.
- The pressure sink airlock - This type of airlock is a negatively pressurized space that pulls the air "IN" from both the areas it protects thus creating a barrier between the two spaces it serves.

By having HVAC and process systems segregated and dedicated to each stage of the process, it is possible to implement cleaning and changeover procedures while maintaining the integrity and cleanliness required for downstream unit operations processing product.

## 6) Use of Air showers and other apparatus

The air showers are of SS-304 construction and are available in various classes such as Class 10, Class 100, with high velocity air outlet nozzles mounted along the two side walls and the ceiling. The air shower will have grated flooring and the return air is taken back to the fan suction through a return air path in the air shower wall.

The equipment used inside a cleanroom is often specialized as well. Specialty manufacturers design and produce sterilized, contaminant-free items made specifically for cleanroom use. These items include glass wear, handling equipment and a full range of manufacturing, research and design tools. Certain cleanrooms may also require specific light levels, acoustic dampening or custom electronic equipment.

## 7) Computational Fluid Dynamics (CFD) Analysis

CFD is a software modeling tool that assists in strategic selection of an optimal air handling system for new cleanroom design, as well as the optimization of existing, under-performing cleanrooms. The CFD primarily does the following tasks:

- Calculate the degree of deviation from vertical airflow,
- Determine area pressure differentials throughout a space,
- Reveal air current disturbances caused by cleanroom tools and other fixtures,
- Determine temperature gradients, and
- Track movement of particles, smoke and airborne molecular contaminants.

This diagnostic tool is highly accurate and it precisely guides the airflow balancing, which in the past has relied upon smoke wands and guesswork performed after cleanrooms were constructed - which is too late to de-bug a cleanroom. Airflow modeling allows you to achieve the same goal on the computer screen before cleanroom construction even begins.

## CLEANROOM ARCHITECTURE AND PHYSICAL STRUCTURE

The selection of construction materials should be made on the basis of durability, whether the material's surfaces can be cleaned and sanitized and how easy it is to do so, resistance to chemicals, and location. Construction materials come in two basic types, hard shell and soft shell. Soft-shell (flexible, plastic materials) cleanrooms are not as durable as hard-shell cleanrooms and have surfaces that are usually more difficult to clean and sanitize; therefore, they should be considered only temporary.

Typical specifications for defining a hard-shell cleanroom are as follows:

1. Walls shall be modular, having locking panels with all joints sealed, or epoxy-coated wallboard. All coverings and sealing materials shall be resistant to cleaning and sanitizing agents.
2. The modular wall panels shall be extruded aluminum grid sections with honeycomb core of varying thickness (from 6 mm to 50 mm). These wall panels shall be of zero out-gassing type, either anodized or powder epoxy coated finish.
3. The walls and ceiling shall be smooth, cleanable surfaces. The interface with the floor and ceiling shall be sealed with approved materials and coved to facilitate cleaning.
4. Raised flooring shall be of die-cast aluminum tiles with perforations for the return passage, installed over a grid work of robust die-cast aluminum pedestals. All the utility and service pipes shall be brought into the cleanroom through these flooring tiles at predetermined locations. Heavy equipment shall also be installed over these flooring tiles at predetermined locations with adequate passage for the return air movement. The floor void beneath the raised floor will act as the return air plenum and has to be designed as a cleanroom floor.
5. Where return air is drawn from lower floor levels, the floor shall be covered with sheet vinyl that is heat sealed or thin-set epoxy resin. The floor surface shall be seamless and cleanable. All coverings and sealing materials shall be resistant to cleaning and sanitizing agents. Materials should be FDA and USDA approved.
6. The ceiling grids shall be extruded aluminum, either anodized or powder coated, which can be ceiling suspended and firmly fixed on to the side walls. The ceiling grids shall be built in recesses for light fixtures and terminal filters. The liquid gel sealant shall make all the joints perfectly leak tight. Commercially available ceiling grids consume approximately 18% of ceiling as dead zone or attic.
7. Architectural details, such as windows, doors, pass-through, and utility penetrations, shall be as ledge free as possible. Window and door frames shall be constructed with double panes and flush frames.

8. The ceiling shall be constructed of epoxy-coated gypsum board or in-laid panels. If the in-laid panel option is chosen, the panels shall be impregnated with material that makes them impervious and hydrophobic. Panels shall be sealed or gasketed to the frame and tied down. The frame materials of construction shall be epoxy coated or anodized.
9. Ceiling penetrations shall meet the following requirements: (a) sprinklers shall be flush mounted, (b) lighting fixtures shall be flush mounted, with smooth, sealed, airtight, exterior-mounted lens surfaces, and (c) utility penetrations shall be caulked or sealed with approved materials.
10. The cleanroom design shall contain a pass-through for materials entering the room from the anteroom. By lessening traffic between the two rooms, the potential for contamination is reduced.
11. Lighting fixture for the Class 100 and better cleanrooms, shall be tear-drop type or flush mounting type (recess type), which can be made leak tight with liquid sealant. Flame-proof and explosion-proof type light fixtures are also available, which are wall mounting type, because of their size and weight.

## **ADMINISTRATIVE MEASURES**

Recommendations include:

- 1) Only authorized personnel can enter the cleanrooms. • Nobody can be allowed into the cleanroom without wearing cleanroom garments including cap and cleanroom shoes.
- 2) Always stay in the “air shower” for a specified time before entering cleanrooms.
- 3) After the use of garments and shoes, they should be kept at a proper place. Never go into “non-clean” areas from change room without removing garments or shoes.
- 4) Do not walk into a cleanroom unless necessary.
- 5) Do not take contamination producing material like tobacco, food, match boxes, purses, cosmetics, card boards and unnecessary papers inside the clean areas. Also do not apply cosmetics in the clean area.

- 6) Do not sharpen pencils in the cleanroom and use a ball point pen only.
- 7) Wear gloves and finger cots whenever required.
- 8) Do not touch contaminated articles or surfaces after wearing finger cots/ gloves.
- 9) Do not scratch your head or rub your nails inside the cleanroom or change room and keep finger nails clean.
- 10) Do not take personal items into cleanroom, keep them in lockers provided.
- 11) Keep your work table clean.
- 12) Clean / change filters in the air conditioning system as and when required.
- 13) Never sweep the cleanroom floors; vacuum them or wet mop them as per frequency specified.
- 14) Clean walls, ceilings and furniture as per frequency specified with wet mop.
- 15) Garments should be washed as per frequency specified.
- 16) Clean all furniture, equipment and raw material packages etc. properly before taking into cleanroom.
- 17) Do minimum maintenance of equipment inside the cleanroom. Take the equipment outside the cleanroom for maintenance.
- 18) Unpacking of the machinery required for the clean areas must be done outside the cleanroom.

### **Conclusion**

Building a cleanroom is a complex exercise carried out in order to assure the product quality within the overall guidelines of good manufacturing practices (GMP) in the industry. As always, owners need to remain committed to performing the due diligence necessary to analyze multiple approaches for a cleanroom's design and construction.