



PDHonline Course M353 (6 PDH)

Commissioning Mechanical Systems

Instructor: George E. Thomas, PE

2012

PDH Online | PDH Center

5272 Meadow Estates Drive
Fairfax, VA 22030-6658
Phone & Fax: 703-988-0088
www.PDHonline.org
www.PDHcenter.com

An Approved Continuing Education Provider

Commissioning Mechanical System(s)

George E. Thomas, PE

CHAPTER 1 INTRODUCTION

1-1. Purpose

This course provides information on the minimum requirements for commissioning mechanical systems supporting major fixed mechanical equipment. The purpose of this course is to provide engineers, facility managers, and others the information necessary to plan for and implement commissioning of mechanical systems. The commissioning process (often referred to as “acceptance testing”) includes achieving, verifying, testing, accepting, and documenting that the performance of mechanical systems meets design intent and the owner and occupant needs. Ideally, the process begins at the program phase and lasts at least one year after project-closeout. The commissioning process involves the participation of all parties in the building delivery cycle, including, but not limited to representatives of the owner, designer and appropriate contractors. At project closeout, systems needed for immediate operation of the facility have been tested and are considered acceptable. Upon achieving final acceptance at the conclusion of the post acceptance period, the last step of the commissioning process, the owner and/or his operating and maintenance (O & M) contractor take over full ownership and responsibility of the mechanical systems.

1-2. Scope

This course material can be used in the process of commissioning mechanical systems in facilities. The commissioning process applies to all phases of a facility’s life-cycle including program, design, construction, acceptance, post-acceptance phases and training of O & M staff, and can be applied throughout the life of the building. This course applies to assessment/testing of new construction (i.e., commissioning), reassessment/retesting of existing facilities, or facilities modified or fitted with new equipment (i.e., re-commissioning), and also to assessment/testing of operating facilities which were not commissioned when new (i.e., retro-commissioning). The requirements of this course are predominantly for testing systems. It is assumed that detailed/comprehensive individual testing of equipment has been completed.

1-3. Objectives

This course objective is to provide information on standardized commissioning and re-commissioning of mechanical systems in support of fixed mechanical equipment in facilities.

1-4. General system testing requirements

The purpose of mechanical systems commissioning is to increase the reliability of mechanical systems after installation by identifying problems and providing a set of baseline values for comparison with subsequent routine tests. A procedure should be developed to include a planned approach (road map) of what should be done in order to verify the proper system installation. This procedure is the commissioning plan. Specific areas addressed in a commissioning plan include the verification of the installation of all equipment/components, interface connections between equipment and individual systems, and interconnection drawings. The development of this plan specific to each system and/or component is key to the usefulness of any maintenance program. The plan consists of the schedule of when acceptance and routine tests should be performed, test forms to be used to record the outcome of the tests which are retained for comparison with previous and subsequent tests, and a listing of the required test devices. Since the results of the commissioning tests become baseline test values to compare with later tests and the results of the routine maintenance tests are

compiled to identify any downward trend in performance, it is vital to the maintenance program to have accurate and complete records. To perform the testing, the plan lists all required tests in order of performance and gives a schedule for each test. The work items and schedule depend on many issues including the importance and cost of the equipment, consequences of failure, age of equipment, past and future frequency of service, hours of operation, future maintenance availability, environmental conditions, and safety requirements.

1-5. Component testing

The reliability of any system is dependent on the interconnection of the equipment and the equipment itself. This course's content is predominately for testing of mechanical systems themselves. It is assumed that the detailed and comprehensive individual testing of equipment has been completed before the commencing of commissioning of the system. However, general testing procedures for the components of the systems described in this course are addressed in chapter 3. Commissioning requirements for the system components must be provided with the original proposal for the procurement of the equipment. The requirements provided by the equipment manufacturer should be adhered to in addition to the recommended testing herein. Although there are many different components to any mechanical system, there are some tests that are common among the equipment. Examples of the common testing procedures include the assembly check, alignment check, grounding verification, insulation resistance tests and polarization index to name a few. These common tests are described in detail later in this course. Sufficient time should be allocated to define the inspections required, perform the check, and document the results. A review of the system drawings will show major pieces of equipment. Specific procedures should be developed for each test referencing the equipment to be used, drawings to be followed, and step by step procedures with readings to be recorded and forms for the results.

1-6. System commissioning testing

Mechanical systems commissioning on new projects is critical to insure that a system is installed properly, is operating properly and efficiently, and that it will remain in service for its projected life cycle. The commissioning of a system encompasses the individual testing of the related components, the verification of the component interconnection against the drawings, and the functional testing of the system as a whole. An understanding of the equipment involved and the modes of operation for a system are essential to the development of the system commissioning plan. A survey of the equipment of the system and listing the equipment in order of importance and startup is the first step in developing the commissioning plan. The schedule of the tests and inspections is dependent on many aspects of the equipment such as its importance and cost, the frequency of service, hours of operation, environmental conditions, accessibility, and safety requirements. The inspection, testing, and startup plan is then developed in conjunction with this schedule with instructions and procedures for the test plan. Examples of systems testing are discussed in chapter 4 through 10. Checklists provided in this course assist in these inspections and tests. They are found as reproducible forms at the end of this course. Problems may arise during the testing of the equipment and systems. In order to identify and correct these problems, troubleshooting techniques should be developed. Checking of equipment such as fuses, lights, and breakers for continuity, equipment calibration and settings, and investigating for faulty equipment or connections should be the first troubleshooting steps. Examples of the possible causes to common problems are shown for each system in the chapters that follow.

1-8. Cost of commissioning

The cost of commissioning for a mechanical system is dependent upon many factors including the system size, complexity and the level of reliability desired. New building construction, renovation of an existing building, or the modernization also will affect the cost of commissioning. Experience has shown that the initial commissioning cost is more than offset by increased system reliability and reduced operating costs. The cost for commissioning a new building can range from 0.5 to 1.5 percent of the total construction cost (shown in the table below). For an existing building the commissioning costs can range from 3 to 5 percent of the total

operating costs. Commissioning costs and savings are further discussed in chapter 2.

Table 1-1 Costs of commissioning, new construction

<u>Commissioning Scope</u>	<u>Cost</u>
Entire building(HVAC, Controls, Electrical, Mechanical) Commissioning	0.5-1.5% of total construction cost
Entire building(HVAC, Controls, Electrical, Mechanical) Commissioning	0.5-1.5% of total construction cost
HVAC and Automated Control System Commissioning	1.5-2.5% of mechanical system cost
Electrical Systems Commissioning	1.0-1.5% of electrical system cost
Energy Efficiency Measures Commissioning	\$0.23-0.28 per square foot

CHAPTER 2 THE NEED FOR COMMISSIONING

2-1. General background

Due to competitive pressures, facility owners look for low cost and abbreviated schedules to bring a facility from concept to operation. These competitive driving forces are reflected in the facility designers' and contractors' prices. To be price competitive, commissioning is often given cursory attention or not included altogether. While owners may be hesitant to delay facility opening, the cost and time invested in proper commissioning produce returns in a number of avenues including cost and energy savings, quality of system operation and more accurate realization of the goals of the project.

a. Complex building systems. Building systems continue to become more complex. Because of this complexity, an ever increasing emphasis must be placed on design, installation and operation error evasion. A commissioning effort will reduce these errors. When systems do not operate correctly, the cost of operation and maintenance increases. The savings which were supposed to be achieved because of the high technical nature of the new equipment and building system components is never realized. The need for commissioning becomes apparent after the owner takes possession of the facility. Tenant complaints, contractor call-backs and, in extreme cases, litigation results in additional costs to resolve inadequate operation of non-commissioned systems.

b. Commissioning today. Commissioning today is continually evolving. Depending on the size of the facilities, the sophistication of their systems, their location, the needs of their tenants and the design intent of the owner, commissioning can be applied in varying degrees to reduce problems and costs for all parties by providing a means to methodically achieve proper system operation.

2-2. The importance of commissioning

The evolution of facility construction and the current need on reduced cost and schedule has lead to design-bid-construct type projects. The owner-engineer-contractor relationship has become confrontational and blame oriented; it thrives on cutting costs through valued engineering and achieving schedule as the goal. The commissioning process, when applied through the life of a facility project, redirects the project to meet the end user's goals.

a. *Commissioning, owner needs.* The owner and tenant using the facility has needs. The purpose of the facility is to fulfill these needs. Therefore from preparation of the design basis document through final acceptance, the emphasis of the project should remain on meeting these needs with reasonable cost and schedule as the goal of the project. When these needs are met, the problems, the costs and the delays are minimized.

b. *Commissioning, goal.* The goal of commissioning as a separate member in the life cycle of a facility project will produce a product suited for the end user. By focusing on the end users' needs as the goal, the commissioning process provides a well honed facility capable of meeting these needs. A smooth operating facility also means less maintenance and operating costs, less facility down time and less facility related interruptions to the user.

2-3. The economics of commissioning

No direct method has been established to determine commissioning costs. Savings resulting from commissioning are difficult to quantify because each construction project is unique and depends on building size, location, complexity, sophistication of equipment and/or systems and the number of systems involved.

a. *Economic benefits.* Unfortunately, qualitative benefits alone will not make a convincing case for commissioning. Although enough studies have been done to produce estimates of the potential savings that can result from performing commissioning, but it is crucial to understand that cost savings are not the sole benefit of a successful commissioning endeavor. The promise of commissioning is to support the facilities equipment operation and the needs of the end user. A successful commissioning project will save the user invaluable time and hassle, especially when dealing with mission critical, "must-not-fail" facilities and will save money in operation, energy use, and costs.

b. *Commissioning cost.* Determining commissioning cost can vary in range from \$0.25 per square foot per year to over \$2.50 per square foot per year. The approximate average appears to be about \$1.00 per square foot per year, but this figure cannot be applied to any specific type of building. Other sources have calculated commissioning costs as 5 to 6 percent of mechanical construction cost, or 0.5 to 3 percent of entire building cost.

c. *Commissioning savings.* The commissioning process can provide savings resulting from the following.

- (1) Improved understanding of the purpose of the facility and the reason for its existence to serve the end user.
- (2) Improved facility and systems because all parties involved in the life cycle are focused on the end users' needs as the primary goal of the facility.
- (3) Improved coordination between the owner, engineer, and contractor resulting in appropriate costs, schedule, and system operation and reduced change orders.
- (4) Improved systems operation, reduced energy consumption, reduced call-backs, and reduced claims and litigation because thorough acceptance tests were conducted, all systems were brought up to operate per design and performance was optimized.
- (5) Reduced maintenance costs because of improved equipment life and reliability.
- (6) Improved maintenance and reduced maintenance man-hours because of available documentation and training.

- (7) Improved building environment resulting in improved worker productivity.

d. *Reported commissioning cost savings.* Cost savings resulting from commissioned versus non-

commissioned facilities for energy savings are reported from 8 to 50 percent with average savings of about \$.75 per square foot. Cost savings resulting from commissioned versus non-commissioned facilities for maintenance savings are reported from 15 to 35 percent. More information on the importance and economics of commissioning can be found in the American Society of Heating, Refrigeration and Air-Conditioning Engineers (ASHRAE).

CHAPTER 3 THE COMMISSIONING PROCESS

3-1 General

The commissioning process should be initiated in the program phase of a project and completed after the post-functional performance phase. As part of this process a commissioning plan needs to be prepared. The plan should address the specific objectives, details and parties involved in each individual project.

- a. Commissioning plan.* The commissioning process applies to all phases of a facility's life-cycle and can be applied throughout the life of fixed facilities. A commissioning plan shall be prepared and shall provide for all activities associated with commissioning. These activities include the following.
- (1) Developing a design basis document.
 - (2) Establishing the commissioning team and their responsibilities.
 - (3) Listing the systems involved.
 - (4) Providing for project cost and schedule impact resulting from commissioning activities.
 - (5) Providing a pre-functional test plan with procedures for testing each system.
 - (6) Providing a functional performance test plan with system test procedures including deferred test procedures for each system.
 - (7) Providing a corrective action plan with procedures.
 - (8) Providing a commissioning documentation filing procedure.
 - (9) Providing a commissioning tracking procedure.
 - (10) Providing requirements for a commissioning final report.
 - (11) Providing training modules for the operating and maintenance (O & M) staff on each system.
 - (12) Providing a training plan and procedures.
 - (13) Providing a system course for each mechanical system.
 - (14) Recommending test and calibration equipment for maintenance.

b. Commissioning process. Additional information on the commissioning process is found in American Society of Heating, Refrigerating and Air-Conditioning Engineers, Inc. (ASHRAE): Guideline 1-1996, The HVAC Commissioning Process, the Department of Energy: Building Commissioning Guide, Version 2.2, and the Department of Energy: Model Commissioning Plan and Guide Specifications, USDOE, Version 2.05.

3-2. Commissioning applicability to project phases

All phases of a facility's life cycle should be addressed in a commissioning plan. The requirements to be addressed in the plan for each phase are discussed below.

- a. Program phase.* During the program phase certain tasks need to be accomplished to initiate the commissioning process. These tasks are part of the commissioning plan and include the following activities.

- (1) Establish a commissioning team. This team needs to have a representative from quality control; the mechanical contractor; the electrical contractor; the testing, adjusting and balancing (TAB) contractor; the controls contractor; the design agent; the contracting officer and the using agency. If contractors are to do a large portion of the testing, a witness of sorts should be employed to represent the owner.
 - (2) Define the responsibilities of each team member.
 - (3) Establish the team member with authority to coordinate the commissioning process, the commissioning authority (CA).
 - (4) Develop a list of the systems involved. This is the first step in preparing a system course for each system.
 - (5) Prepare a design basis document to document commissioning requirements. The requirements establish what is needed by the owner and therefore what is to be obtained from commissioning activities in the project. They establish the desired goal of commissioning which is to provide the facility manager information necessary to achieve, verify, test, accept and document that the performance of mechanical systems meet design intent and the owner and occupant needs. Included in the design basis document is weather data, interior environmental criteria, other pertinent design assumptions, cost goals, and references to applicable codes, standards, regulations and guidelines.
 - (6) Discuss possible impact resulting from commissioning activities. The commissioning process will require human resources, materials and equipment to be implemented.
 - (7) Plan for the total impact of commissioning. Planning needs to include the impact on schedule, equipment, facility, manpower, documentation, supplies, expendables, cost and objectives of the project.
- b. *Design phase.* For continued development of the commissioning plan, the following needs to take place during the design phase.
- (1) Review and update the design basis document.
 - (2) Confirm the systems involved as design progresses as the systems, equipment, components, instruments and their particulars will change during design. The commissioning plan needs to be updated as applicable systems change.
 - (3) Establish pre-functional testing criteria defining the checks and inspections of system equipment and components which need to take place before functional performance testing can start.
 - (4) Develop the pre-functional test plan and include a pre-functional test procedure for each system using the criteria established above. The procedures include checks and inspections which need to be conducted to insure that the equipment, components, instruments, and entire system is ready for functional performance testing. Procedures need to include forms indicating test results, deficiencies found, dates and signature sheets and any other documents needed to authorize commissioning of the system. A comparison of the installed system against design schematics and piping and instrumentation diagrams (P&ID) and a review of as-built documents needs to be included in the procedures.
 - (5) Define functional performance testing criteria for mechanical system equipment and components during this phase as the technical aspects of the mechanical systems are being established at this time and the resources to develop these criteria are readily available.
 - (6) Develop the functional performance test plan using the criteria established above. Functional performance test procedures for each system must be prepared. The functional performance test with sign-off authorization is required for official system acceptance by the CA. The functional performance test plan incorporates all functional performance test procedures including deferred functional performance test procedures. Procedures need to include forms indicating test results, deficiencies found, dates and signature sheets and any other documents needed to authorize acceptance of the system.

- (7) Identify deferred functional performance test procedures and include them in the functional performance test plan. Functional performance tests which require seasonal conditions or startup of other systems as prerequisites need to be deferred until the conditions are met and/or the systems are available and functioning properly. Once systems requiring deferred tests are identified, a deferred functional performance test procedure needs to be prepared for each and included in the functional performance test plan. Procedures need to include forms indicating test results, deficiencies found, dates and signature sheets and any other documents needed to authorize acceptance of the system.
- (8) Define recommended test and calibration equipment for maintenance needs. This equipment is most easily defined during the design phase because the technical aspects of the mechanical systems are being established at this time and technical resources are readily available.
- (9) Develop a corrective action plan to handle pre-functional, functional performance, and deferred functional performance testing deficiencies discovered during commissioning. These deficiencies need to be recorded, corrective actions taken, corrective actions Prepare a design basis document to document commissioning requirements. The requirements establish what is needed by the owner and therefore what is to be obtained from commissioning activities in the project. They establish the desired goal of commissioning which is to provide the facility manager information necessary to achieve, verify, test, accept and document that the performance of mechanical systems meet design intent and the owner and occupant needs. Included in the design basis document is weather data, interior environmental criteria, other pertinent design assumptions, cost goals, and references to applicable codes, standards, regulations and guidelines.
- (10) Develop a commissioning documentation filing procedure to retain commissioning process plans, procedures, tests, test reports, corrective actions, verification reports, tracking reports, training modules, training status reports, other status reports, deficiencies, the final commissioning report, and many forms, reports, drawings, sketches, signature sheets, sign-offs and other documents for all systems at all phases and steps in the process. This procedure will provide a method of filing/retaining/retrieving documents and a schedule for their retention. It will also establish the individual having authority for the system and location and conditions of storage.
- (11) Develop the commissioning tracking procedure as part of the commissioning plan to track the status of all commissioning plans and procedures, tests, test reports, corrective actions, verification reports, tracking reports, training modules, training status reports, other status reports, deficiencies, the final commissioning report, and any forms, reports, drawings, sketches, signature sheets, sign-offs and other documents for all systems at all phases and steps in the process. This procedure will track all activities and documents in the commissioning process and at any time provide readily generated reports on the status of any item, system or process.
- (12) Develop the commissioning final report outline and include an introduction; description of the facility; purpose of commissioning facility systems; description of how through commissioning the requirements of the design basis document have been achieved; summary of commissioning activities; summary of commissioning results and official authorization that the facility has been turned over to the owner to be managed by the facility manager. The report shall have a signature page.
- (13) Develop training modules for the O & M staff as part of commissioning training. Training modules on maintenance and operation must be prepared for each system.
- (14) Develop the training plan in order to insure that O & M staff are properly trained on mechanical systems and that their training remains current. For the purpose of commissioning and the systems involved, procedures are needed for defining training requirements, developing modules, updating training modules, conducting training, tracking the status of trained staff and modules and maintaining current training modules and records for each system. These procedures need to be prepared during the design phase and included as part of the training plan.
- (15) Prepare an initial system course for each mechanical system. Each system course shall include a drawing and equipment list; drawings; equipment specifications; and manufacturers' equipment installation, maintenance and operating instructions.
- (16) Adjust the project's schedule and cost resulting from development and refinement of

commissioning activities. The impact on the project must constantly be adjusted for changes resulting from commissioning activities as the commissioning process evolves.

c. Construction phase. Most of the commissioning activities defined in the design phase can be conducted in the construction phase; however, the technical staff required is more readily available in the design phase. Based on as-built systems the following need to be confirmed in the construction phase.

- (1) Design basis document.
- (2) List of systems involved.
- (3) Pre-functional test plan and procedures.
- (4) Functional performance test plan and procedures.
- (5) Deferred functional performance test procedures.
- (6) Recommended test and calibration equipment for first and second echelon maintenance.
- (7) Corrective action plan.
- (8) Commissioning documentation filing procedure.
- (9) Commissioning tracking procedure.
- (10) Commissioning final report outline.
- (11) Training modules for the O & M staff.
- (12) Training plan.
- (13) Commissioning team and responsibilities.
- (14) Contents of system courses.
- (15) Impact to the projects schedule and cost resulting from development and refinement of commissioning activities and construction activities must be accounted for with revised schedules and costs.

d. Functional performance phase. The functional performance phase is when tests are conducted and results recorded. Some overlap may be possible allowing pre-functional tests to be conducted as systems are completed and as-built documents are being prepared. Functional performance tests may be conducted on some systems as construction on other systems is being completed. After completion of the functional performance phase the project is closed. Mechanical systems necessary for immediate operation of the facility have been functional performance tested and signed off. The facility will be turned over to the owner with some exceptions. Completion of some deferred tests, some guarantee/warranty work, and/or some corrective actions may remain to be conducted in the post functional performance phase. During the functional performance phase the following need to be implemented.

- (1) Pre-functional test plan and procedures.
- (2) Functional performance test plan and procedures.
- (3) Deferred functional performance test procedures.
- (4) Corrective action plan.
- (5) Commissioning documentation filing procedure.
- (6) Commissioning tracking procedure.
- (7) Commissioning final report preparation – first draft.
- (8) Training of the O & M staff.
- (9) Training plan.
- (10) Review of the design basis document.
- (11) Preparation of system courses

e. Post-functional performance phase. The post-functional performance phase may take up to one year after project-close-out occurs. Final functional performance comes at completion of the post-functional performance phase. Tests conducted for re-commissioning are conducted after the post-functional performance phase of the commissioning process to re-confirm the readiness of systems or modified systems to

meet their design or modified design intent. To conduct re-commissioning activities, commissioning activities on the original facility must be complete. To conduct retro-commissioning activities, a facility which has been in operation but never commissioned must go through the commissioning process. Post-functional performance includes the following.

- (1) Completion and functional performance sign-off of remaining deferred tests, guarantee/warranty work, and/or corrective actions.
- (2) Implementing the commissioning documentation filing procedure.
- (3) Preparing the commissioning final report – final draft.
- (4) Issuing the commissioning final report.
- (5) Completing training of the O & M staff.
- (6) Implementing the training plan.
- (7) Preparation of an updated/revised final design basis document.
- (8) Preparation of final system courses.

CHAPTER 4

HEATING, VENTILATING, AND AIR-CONDITIONING (HVAC) EQUIPMENT AND CONTROLS

4-1 Description of HVAC systems

Heating, ventilating, and air conditioning (HVAC) of facilities/buildings is accomplished in many ways, depending on the size, configuration, and location of the buildings and the degree of environmental control needed. Small simple facilities in temperate climates can be heated and cooled with a separate heating and a separate cooling unit or with a combination heating/cooling unit. Larger facilities employ refrigeration systems and heating systems which may consist of several large units or centralized systems. Facility complexes may treat each facility separately or provide a dedicated building to house central refrigeration and heating systems. Depending on the HVAC units or systems employed, air is treated through the use of ducts, coils, fans and dampers. Liquids are moved through pipes by pumps. Gases are moved through pipes or tubing by compressors. Air is moved through ducts by fans. The amount of flow of these fluids is controlled by valves and dampers that can operate manually or automatically. Various types and kinds of filters may be used at different locations for air, gas or liquids. Building air is recirculated, some building air is exhausted, and outside air is introduced in various ways as make-up air. Various energy sources may be used in HVAC systems including oil, natural gas, propane, coal and electricity. Other equipment such as humidifiers, energy savers/economizers, heat exchangers, expansion tanks, air separators, secondary pumping systems and smoke management systems may be employed. HVAC systems may also be connected to fire safety and alarm systems.

a. Typical HVA C system. An HVAC system is shown in figure 4-1. The system consists of ducts, dampers with actuators, filter, fan, heating coil, cooling coil, piping, valves with actuators, pumps, boiler, chiller, expansion tanks and air separators.

b. Typical heating/chilled water flow control. A typical heating/chilled water flow control through a oil is shown in figure 4-2 and 4-3. The loop consists of a heating/cooling coil, flow control valve, actuator, positioner, temperature sensor, temperature controller and instrument signal to pneumatic signal converter.

c. Other HVA C equipment. Paragraph 4-3, General HVAC equipment description and operation, explains the operation of various types of boilers and chillers including the packaged units presented here. For more information on design, maintenance, testing, instrument calibration and commissioning of HVAC systems see the American Society of Heating, Refrigerating and Air Conditioning Engineers, Inc. (ASHRAE): Guideline 1-1996, The HVAC Commissioning Process, and The American Society of Mechanical Engineers (ASME).

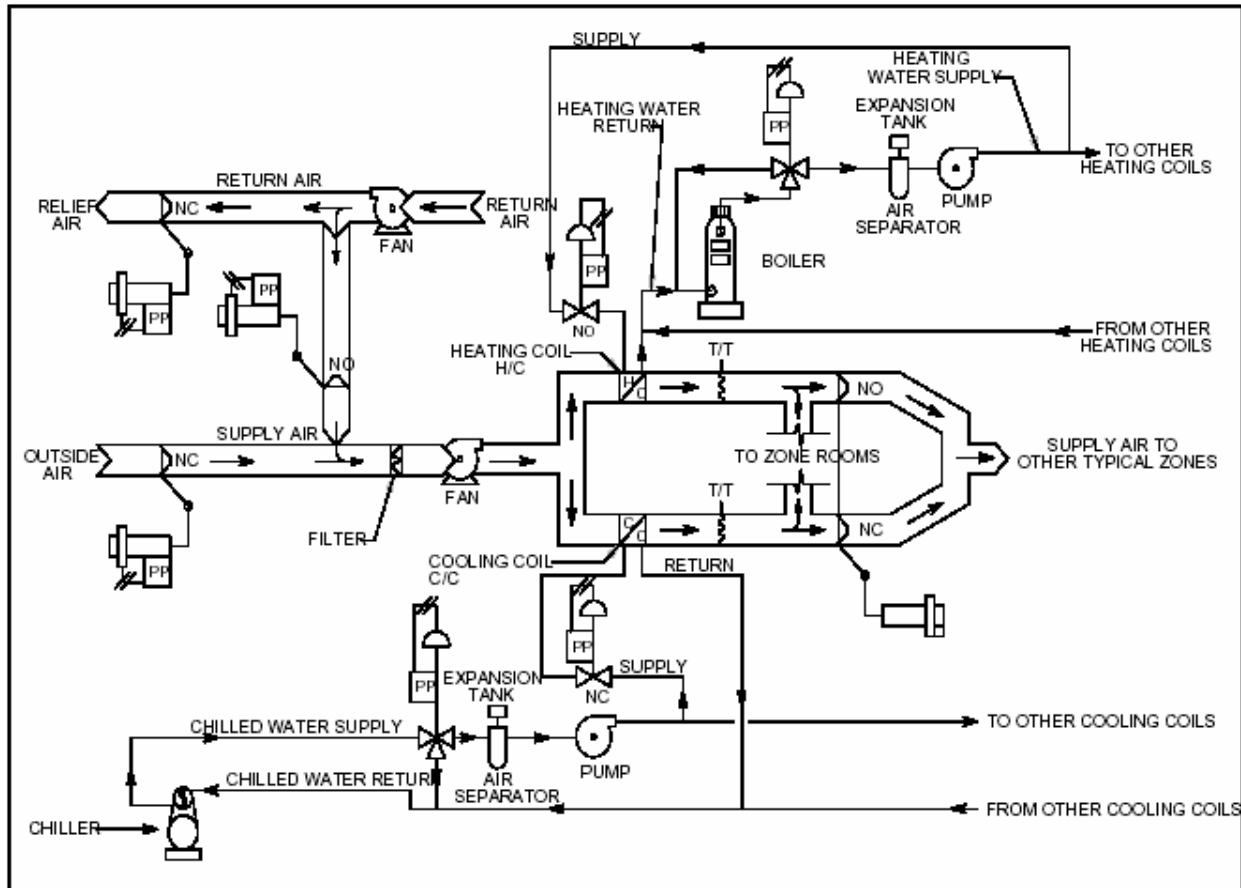

Figure 4-1. Schematic of a typical HVAC system

4-2 Operation of HVAC systems

Operation of a typical HVAC system and a typical HVAC control loop are discussed in the following paragraphs.

- a. *HVA C system operation.* In the HVAC schematic shown in figure 4-1, interior building air is transported in ducts. A relief air port in the system discharges return air to the outside. An outside air port allows fresh air to enter the HVAC system. Three modulating dampers adjust the amount of outside air entering the system. Some of the return air from HVAC zones is mixed with outside air, filtered and divided into two streams. One supply air stream passes over a heating coil and is delivered to rooms located within the zone. The other supply air stream is cooled with a chilled water cooling coil, before being supplied to the same rooms within the same HVAC zone. Excess supply air is then mixed together before flowing to other zones. Separate dampers in the heated and cooled air streams adjust air flow to the zone before mixing. Once the mixed air is taken to another zone it will be split again and heated and cooled in a similar way before being supplied to building rooms within the next zone.
- b. *HVAC control loop operation.* Supply air is heated or cooled by passing over a heating coil (H/C) or a cooling coil (C/C) respectively. The flow of water in the coil is controlled by measuring duct air temperature with a sensor TT downstream of the coil. Refer to figure 4-2, Typical HVAC control loop. The measured temperature signal is interpreted by the controller TC and compared against a set point temperature established by a thermostat or an energy management control system (EMCS). To adjust liquid flow in the variable liquid volume (VLV) control valve, the controller produces an instrument signal usually 4 to 20 milliamperes. In a pneumatic loop a signal converter, IP, converts this signal to a 3 to 15 psi signal.

15 psig (pounds per square inch gauge) pneumatic signal. Tubing supplies the pneumatic signal to a pneumatic positioner (PP) on the heating/cooling water control valve VLV. The positioner is mechanically connected to a diaphragm actuator indicating valve stem position. The actuator incorporates a spring which maintains the valve in an open or closed position [normally open (NO) or normally closed (NC)] depending on the control scheme, when no air is supplied to the top of the diaphragm. The pneumatically positioned actuator and VLV valve are often assembled as a unit. The positioner interprets the pneumatic control signal and using the shop air supplied to it, directs more or less air to the side of the diaphragm opposite the spring on the actuator. This air pressure moves the diaphragm which moves the valve stem, changing the amount of liquid flowing through the valve and coil, therefore changing the amount of heating or cooling imparted to the air stream flowing over the coil.

- (1) Water flow through the boiler is maintained at a constant rate with a three-way control valve. Temperature sensors in the packaged boiler allow burner controls to adjust fuel flow and therefore the BTU content of the heating water.
- (2) Water flow through the chiller is maintained at a constant rate with a three-way control valve also. Temperature sensors in the packaged chiller allow controls to adjust refrigerant flow and therefore the BTU content of the chilled water.

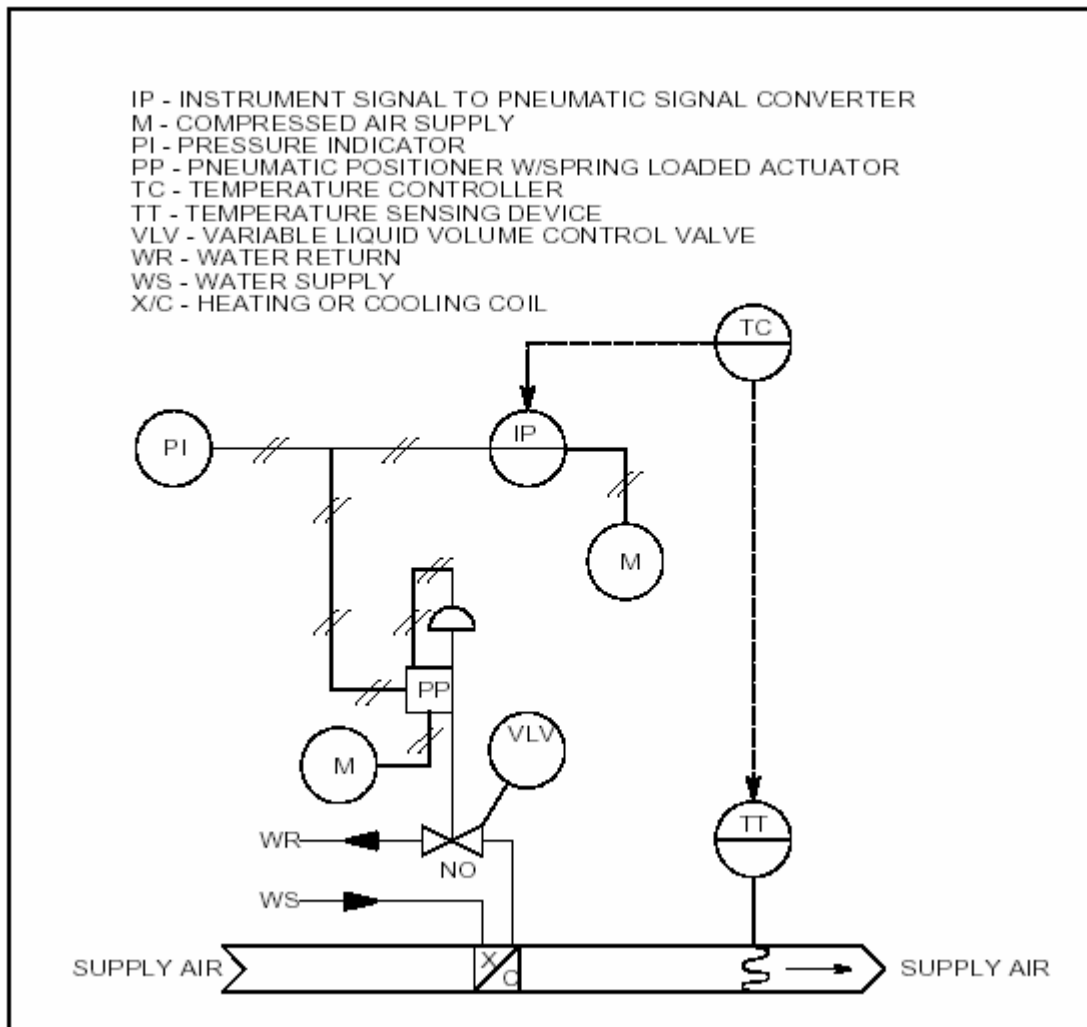

Figure 4-2. Typical HVAC control loop

4-3. General HVAC equipment description and operation

The following chapters describe some of the equipment used in various combinations to produce an HVAC system. A description of the equipment and its operation is provided.

a. Refrigeration systems. Refrigeration systems are most often supplied skid mounted as a packaged unit. The assembled package includes all major components and controls mounted and pre-wired requiring only that they be anchored to a foundation, hooked up to the hydronic piping system, connected to a treated water supply and connected to power. There are two basic refrigeration cycles: one compresses the refrigerant gas and the other absorbs the refrigerant at very low pressures. Chillers which chill water are often called chillers. Chillers can be packaged units or field assembled units.

- (1) In the compression refrigeration cycle, HCFC-22 and HFC 134a refrigerants remove heat from a medium by changing phases. The refrigerant is compressed in its gaseous phase and passed through a condenser. Outside air or water from a cooling tower passes over the condenser coil to remove heat in one of three ways as discussed below under heat rejection equipment. The refrigerant gas leaving the condenser is then expanded through a valve which lowers its pressure and temperature further until a phase change occurs and a liquid is formed. This now cool, liquid will boil at approximately 20° to 30°F. The liquid refrigerant then passes through an evaporator coil and boils. Water or air flowing through the evaporator gives up its heat to the cold refrigerant making it boil. Entering water temperature is usually 54°F. It is usually chilled to 44°F and is called chilled water. It is treated with cleaning, anti-scaling, anti-fouling, anti-corrosion and anti-freezing agents. The chilled water is pumped to coils in air handling units (AHU) and ducts where building air or room air is passed over the coil thus cooling the air. Chilled water is often called brine because of salts added to condition the water. When building/room air is passed directly over evaporator coils and the chilled water system eliminated, the system is referred to as direct expansion (DX). DX units are located near the area to be cooled and do not use water as an intermediate medium to condition the air.
- (2) Drip pans are placed under cooling coils to collect condensate resulting from cooling building/room air and dropping its dew point temperature. Condensate flows by gravity to a sanitary drain or is collected and pumped to a drain. There are several types of chillers as discussed in the following paragraphs.
- (3) Centrifugal chillers use centrifugal compressors to compress the refrigerant gas. Centrifugal compressors compress gas as it enters the center of a fluted casting, housing a rotating impeller. The impeller imparts kinetic energy to the gas which turns into potential energy as the gas velocity slows, thus increasing pressure. Compression is a continuous process. One, two, or three stages may be used. Centrifugal compressors are used in large systems.
- (4) Reciprocating or positive displacement chillers use reciprocating or piston type compressors to compress the refrigerant gas. The gas enters a cylinder through a valve when a piston in the cylinder is going down. The valve closes when the piston starts to go up. As the piston approaches the top of the cylinder the gas is compressed by the decreasing volume. An exhaust valve opens when the piston is near the top of the cylinder allowing the compressed gas to exit. The cycle is then repeated.
- (5) Rotary screw chillers use rotary helical screw compressors to compress refrigerant gas or increase the pressure of liquid refrigerant. They are positive displacement machines. The twin-screw compressor consists of accurately matched rotors [one lobe (male) and one helix (female)] that mesh when rotating within a close tolerance common housing. One rotor is driven and geared to the other, turning it in a counter-rotating motion.
- (6) Scroll chillers employ a stationary scroll and a motor driven orbiting scroll to gather refrigerant gas at the circumference and move it through an ever decreasing volume to the center of the scroll where

it exists at a higher pressure.

- (7) In absorption chillers the absorption cycle uses a heat-driven concentration difference to move refrigerant vapors (usually water) from the evaporator to the condenser. The high concentration side of the cycle absorbs refrigerant vapors, diluting the absorbent material, usually lithium bromide. Absorption chillers are typically found in large or small systems. Systems with medium cooling loads typically accomplish the demand through use of other types of cooling units.
- (8) In the evaporator, water at about 40°F is evaporating off the chilled water tubes, thereby bringing the temperature down from the 54°F being returned from the air handlers to the required 44°F chilled water supply temperature. The water vapor is absorbed by the concentrated lithium bromide solution due to its hygroscopic characteristics. The heat of vaporization and the heat of solution are removed using cooling water. The solution is then pumped to a concentrator at a higher pressure where heat is applied (using steam or hot water) to drive off the water and thereby re-concentrate the lithium bromide.
- (9) The water driven off by the heat input step is then condensed using cooling tower water, collected, and then flashed to the required low temperature of 40°F to complete the cycle. Since water is moving the heat from the evaporator to the condenser, it serves as the refrigerant in this cycle.
- (10) Lithium bromide is the most common absorbent used in commercial cooling equipment, with water used as the refrigerant. Lithium bromide has a very high affinity for water, is relatively inexpensive and non-toxic. However, it can be highly corrosive and disposal is closely controlled. Smaller absorption chillers sometimes use water as the absorbent and ammonia as the refrigerant. Ammonia absorption is used in recreational vehicles and food processing plants.
- (12) Absorption chillers must operate at very low pressures, about 1/100th of atmospheric pressure for the water to vaporize at the required ~ 40°F.
- (13) Absorption chillers are available in two types, single effect (stage) units using low pressure (20 psig or less) as the driving force and 9 psig steam at the generator, and double effect (two-stage) Units available as gas-fired or steam-driven with high pressure steam (40 to 140 psig). To achieve their improved performance they have a second generator in the cycle and require a higher temperature energy source.

b. Heating systems. To heat building/room air, heating water coils are mounted in ducts. The heating water receives its heat directly from a hot water boiler or from a heat exchanger. Entering the heat exchanger is high temperature hot water or steam which provides heat for the heating water system. Building/room air can also be heated directly in an air heating furnace or by passing over the evaporator turned condenser in a direct exchange heat pump system.

- (1) Heating generators are most often supplied skid mounted as a packaged unit. The assembled package includes all major components and controls, mounted and pre-wired requiring only that they be anchored to a foundation, hooked up to the hydronic piping and duct systems, connected to a fuel supply and treated water supply, connected to a stack and connected to power. Following is a discussion of various heat generators.
- (2) Boilers burn natural gas, propane, oil or coal or use electric to produce steam, high temperature water and hot water. A boiler can be provided in each building for heating or a central location for heating a complex of buildings. In a firetube boiler, gaseous products of combustion pass through tubes surrounded by the water to be heated. In a watertube boiler, water passes through the tubes as the products of combustion passes over them. In an electric boiler, electric heating elements are inserted directly into the water. Depending on temperature and pressure the water will vaporize into steam, become high temperature water, or become hot water. Steam can be piped directly to individual room heaters of various types or can be used in a heat exchanger to condense, transferring the heat of vaporization to heating water. High temperature hot water boilers work in a similar fashion but produce high temperature water instead of steam. Hot water boilers produce

- hot water from 140 to 180°F for direct use in heating coils to heat building or room air.
- (3) Air heating furnaces burn natural gas, propane, or oil, or use electric to produce hot air to be used directly in heating building space or rooms. An air heating furnace is usually provided in each building for heating. When fuel is burned, the products of combustion are mixed with excess air and flow inside of a tube bundle or heat exchanger to heat the building/room air passing over the outside of the tube. When electric is used, heating elements are inserted directly into the air stream.
 - (4) Heat pumps are discussed below in paragraph 4-3f, Unitary heat pump/air-conditioning equipment.

c. Heat rejection equipment. Heat rejection equipment is most often supplied skid mounted as a packaged unit. The assembled package includes all major components and controls mounted and pre-wired requiring only that they be anchored to a foundation, hooked up to the piping system, connected to a treated water supply, and connected to power. A discussion of heat rejection equipment including cooling towers, evaporative condensers and air cooled condensers to remove heat from the condenser coil of a refrigeration machine follows.

- (1) Water from a cooling tower may be passed through the condenser to remove heat. Under full load conditions the design condenser cooling water inlet temperature is 85°F and leaving temperature is 95°F. The cooling tower water can then be directly exposed to outside air to reject heat from the water. This water is treated for corrosion, fouling, and scaling and is circulated from a basin in the bottom of the tower. Cooling towers may also use a closed loop for condenser water. A coil is installed in the tower; condenser water is pumped through it and therefore not exposed to the atmosphere. The water basin in the tower now provides water to spray over the tower coil. This with the assistance of a fan removes heat from the condenser water. This basin water is also treated for corrosion, fouling, and scaling.
- (2) An evaporative condenser is placed directly over a basin, water from the basin is sprayed, and air is forced over the coils resulting in cooling of refrigerant in the coils. At full load conditions the design entering air dry bulb temperature is usually 95°F and entering air wet bulb temperature is 75°F.
- (3) An air cooled condenser has outside air passed over it, the refrigerant in the coil is cooled directly by the air. At full load conditions the design entering air dry bulb temperature is 95°F. Entering condenser refrigerant vapor temperature is 190°F. Leaving condenser refrigerant temperature is 125°F.

d. Air handling equipment and systems. Air handling equipment is designed to condition air in rooms or in designated areas in a building called zones. In an AHU air is moved through filters and over coils to clean, heat or cool it. Fluid flow in coils or air flow through the AHU can be adjusted for interior environmental control. Following are variations of AHUs.

- (1) A single-zone AHU controls interior building air in one building zone. There may be several rooms in one zone.
- (2) Multi-zone AHUs control interior building air in two or more building zones.
- (3) A variable air volume (VAV) AHU controls interior building air by varying air flow over the coils as opposed to the usual way of varying the flow of the heating water and chilled water through the coils.
- (4) A terminal unit VAV (dual duct) unit is located at the end of a heating air and cooling air supply duct and controls interior building air by varying the air volume and mix.
- (5) A terminal unit dual duct fan series AHU is located at the end of a heating air and cooling air supply duct and controls interior building air by varying the air volume with the use of local fan(s).
- (6) Terminal units with cooling are located at the end of a heated or non-heated air supply duct and include a cooling coil for control of interior building air.
- (7) Terminal units with and without fans are located at the end of a conditioned air supply duct and may

- or may not include a fan for control of interior building air.
- (8) DX air units control interior building air by using a DX coil in the air stream. In the DX coil the fluid flowing inside of the coil is a refrigerant. Generally this coil is for cooling but it can be used for heating as well.
 - (9) Fan coil units are AHUs which control interior building air with a coil to change air temperature and a fan to force the air over the coil and into the building.
 - (11) Unit heaters usually employ a fan to circulate air within an area or zone and have no supply or return air duct or system of ducts. To control building air, steam coils, hot water coils, electrical elements, or direct gas fired heat exchangers may be used for heating. Radiant heaters use gas and sometimes electric to heat a ceramic surface. Heat is transferred by radiation to the floor and objects in the room which then heat air by free convection instead of forced convection as is accomplished in most AHUs.
 - (12) Base heater units consist of an electric element or a finned tube with hot water flowing inside the tube. These units heat interior air by free convection or sometimes incorporate a fan to heat air by forced convection. They heat air in the local vicinity of the heater.
 - (13) A computer room unit is prepared for controlling the environment in a computer room. This includes provisions for filtering, heating, cooling and humidity control. Humidity control is usually provided by increased cooling capacity and reheating of the air through additional heating capacity.
 - (14) A packaged roof top unit is an AHU with its duct, coils, fans and controls packaged in a weather proof box and is provided with weather proof components to withstand the elements. It is also designed to be supported on a roof with supply and return air ducts located on the bottom of the unit.
 - (15) An economizer is a gas-to-gas, liquid-to-gas or liquid-to-liquid heat exchanger which, when practical, is used to salvage waste heat from a process or part of an HVAC system. The waste heat is used to pre-heat heating air thereby reducing the amount and cost of heating. The heating system is therefore more economical to operate with an economizer installed.
 - (16) Variable speed fans are used in units where a variable volume of air flow is required. Variable speed fans may be provided in place of a central fan and may incorporate inlet guide vanes and/or modulating dampers.

e. Unitary heat pump/air-conditioning equipment. Unitary heat pumps are factory-packaged refrigerant based units. They can provide cooling or heating of interior building air. Both heating and cooling of air can be provided if a refrigerant reversing valve and associated controls are included. This valve reverses the flow of refrigerant transforming the evaporator into a condenser and the condenser into an evaporator. In this way heat can be moved (pumped) from inside building air to the outside in the summer, and from the outside to inside building air in the winter. Provisions are provided to collect condensate from cooling interior air and connection to a drain is needed. Heat pumps and air- conditioning equipment are available in a number of application categories which include the following.

- (1) A packaged terminal heat pump (PTHP) unit is designed to be installed at the end of a building interior air supply duct. It includes appropriate duct connections, coils, fans and controls packaged in one box. It is also designed to be supported from overhead.
- (2) Single packaged units have their duct, coils, fans and controls packaged in one weather proof box and are provided with weather proof components to withstand the elements. They are designed to be located outside and supported on a concrete pad or steel frame from the bottom with supply and return air ducts located horizontally or vertically. Console under window units are also available without duct connections.
- (3) A roof-top packaged unit has its duct, coils, fans and controls packaged in a weather proof box and is provided with weather proof components to withstand the elements. It is also designed to be supported on a roof with supply and return air ducts located on the bottom of the unit.

- (4) Split heating, air conditioning, and heat pump units have their ducts, coils, fans and controls packaged in two boxes. A weather proof exterior box for the compressor, condenser coil, condenser fan and controls is designed to be supported on a concrete pad or steel frame from the bottom. An interior box is provided with supply and return air duct connections, fan and drip pan. Connections for refrigerant tubing are provided on both boxes. This tubing is routed as needed and insulated to prevent heat loss or gain in the refrigerant and to prevent condensate from forming on the tubing.
- (5) Ground source heat pumps (GSHP) are typically installed indoors. One box contains the compressor, pump, fans, duct connections and controls, but often components are not included in the central box to adapt the system for the user's needs. The box is connected to underground piping networks that exchange heat with the ground. These pipes can be closed loops, buried only feet underground or connected to sources of water such as wells or ponds. A desuperheater can also be employed during the summer months to extract heat from the conditioned air for hot water heating.

f. HVAC control systems. HVAC control systems are used to control heating, cooling, and ventilating of interior building/zone/room air and are also used in fire safety control schemes

- (1) Direct digital control (DDC) HVAC control systems use sensors, electric actuators, and microprocessors to provide a marked upgrade in system functionality over that attainable with pneumatic control. DDC systems provide operators the ability to remotely monitor existing conditions, change setpoints, diagnose and sometimes fix problems from a workstation or laptop PC. A single operator could monitor many buildings with DDC control, in addition to performing other operating and maintenance (O & M) tasks. Energy management and reporting functions improve operational efficiency and cost savings. Operational problems can be identified early and fixed before they become larger and more expensive. DDC systems involve vendor-specific application software and a communications network. Each software application provides varying degrees of flexibility and a unique software approach to DDC. The systems are often incompatible.
- (2) Fire safety air moving systems provide fire safety to air zones and to stairwells by moving air or smoke. These systems provide for smoke removal only or air pressurization only to help keep areas clear of smoke and provide fire control. They may also use a combination of smoke removal with air pressurization to isolate an air zone for fire safety control.
- (3) EMCS manage heating and cooling in a building or zone of a building according to programmed time and temperature schemes for efficient use of energy.
- (4) Hydronic systems supply controlled chilled and heated water to cooling or heating coils. In hydronic systems an air separator is incorporated to remove air from the water and an expansion tank is provided to account for changing density in the water. Secondary piping systems are used to circulate water in secondary loops located in different buildings or zones which branch off of the main or primary heating or cooling water supply loop.
- (5) Ventilation systems provide circulation of controlled conditioned and filtered air to building zones or rooms and incorporate exhaust air relief and make-up outside air.

g. Smoke management systems. HVAC systems can interface with fire detection/alarm systems. When HVAC control systems interface with fire systems, signals from the fire system are used to take action to minimize the fire and/or provide safe shut down of equipment.

- (1) Smoke management systems can use smoke dampers to inhibit the passage of smoke from one zone to another. By appropriate opening and closing of smoke dampers in HVAC ducts, building zones free of fire can be pressurized with air while the zone with the fire can have smoke pulled from it.
- (2) Fire dampers are dampers which close when a fuseable link melts and permits the damper to close.

This prevents air movement in the duct which helps limit the fire and prevents smoke from flowing in the duct.

- (3) Fire stops and smoke barriers are fixed obstacles provided to stop the movement of fire or smoke in walls or ceilings.
- (4) Automatic and course control can be used in HVAC control systems for fire safety and smoke management. Air distribution systems have coarsely operated devices that stop the operation of supply, return and/or exhaust air and fans in an emergency. Automatic shutdown capability automatically, according to a predetermined fire management plan, closes dampers and shuts down fans when detectors located in the supply ducts, return ducts or the building fire protection system detect a fire.
- (5) Proper gasketing and sealing of doors is needed to prevent air infiltration into a zone during a fire.
- (6) Door release hardware and automatic door openers provide for opening doors for human egress and to control fire and smoke as predetermined in a fire management plan.

h. Ducting. HVAC ducts come in various configurations including round, square, rectangular and round oval. They are made from iron, concrete, galvanized steel, rigid fibrous and flexible materials. Metal ducts which supply cooling air must be insulated. Duct systems must be tested for leaks and cleaned before being put into service. Ducts can incorporate heating coils, cooling coils, DX coils, flow switches, pressure switches and gages, smoke detectors, heat detectors and dampers for system control.

i. Piping systems. Piping systems supply steam, high temperature water and hot water for heating and chilled water for cooling. These systems also provide make-up water to boilers and return steam condensate to boilers. Condensate from cooling coils is taken to a drain by pipe systems. Pumps move fluids, and steam is moved by pressure differential.

- (1) Pipe systems may include steam/hot water converters which heat water with steam by using a heat exchanger, finned tube radiators which heat room air by natural convection, control valves operated by the HVAC control system for shutting off and controlling fluid flow, solenoids electrically actuated for stopping fluid flow, and relief valves to prevent over pressure of vessels and systems. Hydronic piping systems incorporate air separators and expansion tanks and must be adjusted and balanced before being put into service. Piping systems must be hydrostatically tested for leaks before being put into service. Piping can incorporate flow switches, pressure switches and gages, thermometers and thermo-wells, solenoids and relief valves for system control.
- (2) Piping systems come in four types: 1-pipe, 2-pipe, 3-pipe and 4-pipe. The limitation of 1 and 2-pipe systems is that they can only operate in one mode at a time; heating is typically provided for a portion of the year while cooling is provided for the remainder. In 3 and 4-pipe systems, different users in the same building can call for heat or cooling at the same time, Two and 4-pipe systems are more efficient and consequently more expensive than their respective 1 and 3-pipe pairs.

4-4. Pre-functional test plan and functional performance test plan for HVAC systems

It should be assumed that individual components and packaged equipment has been tested by the manufacturer. As part of the commissioning effort each component should be checked for damage, deterioration and failures by a procedure using inspections and tests defined by the specific equipment manufacturers. Equipment courses from manufacturers identify the minimum required receipt inspections, handling and installation procedures, drawing and wiring verification, field inspection and installation checks, verification of removal of shipping braces, inspection of installation against drawings and nameplates, inspection of components for damage and cleanliness, inspection of insulators and grounding, inspection of anchorage and alignment, adjustment checks, mechanical operation and interlock checks, lubrication application and verification that local safety equipment is in place.

a. Safety, HVAC. Many tests on equipment involve the use of high voltages, high currents, high pressures, high temperatures and rotating or moving equipment. These can be dangerous to personnel and damaging to equipment. A procedure should be followed to insure adequate safety rules are instituted and practiced to prevent injury to personnel performing the tests and other personnel who might be in the local area.

b. Test equipment, HVAC. It is important that in any test program the proper equipment is used. The equipment should be calibrated, in good condition and used by qualified operators as required by a procedure. Any test equipment used for calibration shall have twice the accuracy of the equipment to be tested. All equipment should be operated in accordance with its instruction course.

c. Procedures, HVAC. A procedure defining installation inspection and a system test needs to be provided for each system. In the HVAC system there are three basic systems: a heating water system, a chilled water system and a building air or ventilating system.

d. Inspection checklists, HVAC. Inspection checklists for HVAC systems, chilled water systems, and ventilation systems are presented in figures 4-3, 4-4, and 4-5. They are filled out to serve as examples of typical equipment conditions. For convenience, these checklists are included unpopulated at the end of this course material.

4-5. Possible failures and corrective measures for HVAC systems

Table 4-1 lists general problems that may arise during the testing of equipment and systems along with possible troubleshooting techniques. For all problems, consult equipment and component courses for troubleshooting directions. Check fuses/lights/breakers/etc. for continuity; check equipment calibration and settings; check for clogged filters and strainers; check for closed course shut-off valves and dampers; check for improperly adjusted valves, dampers and equipment and look for faulty equipment and connections.

HEATING WATER SYSTEM INSPECTION CHECKLIST						
SECTION A- CUSTOMER DATA						
1. PLANT East Building		2. LOCATION Washington, DC		3. JOB NUMBER EB-18		
4. EQUIPMENT		5. HEATING WATER LOOP DESIGNATION HHW-02		6. DATE (YYYYMMDD) 20021125		
7. TEST EQUIPMENT Ritchie gas menometer kit, Fluke calibrated multimeter				8. TESTED BY Roger Swanson		
SECTION B- EQUIPMENT DATA						
9. BOILER MANUFACTURER York Shipley		10. MODEL NO SPL 500-6-97493	11. SERIAL NO 63-8384 H32093		12. BTU RATING N/A	
13. PUMP MANUFACTURER Bell & Gossett		14. MODEL NO BG-452	15. SERIAL NO 87-2602-A/G		16. RATED FLOW 2.5 gpm	
17. HP @ RPM		18. RATED NPSH		19. RATED PRESSURE 30 psi		
SECTION C- VISUAL AND MECHANICAL INSPECTION						
20.	CHECKPOINT	COND*	NOTES	CHECKPOINT	COND*	NOTES
	EXTERIOR OF EQUIPMENT	R		EQUIPMENT IDENTIFICATION	A	
	COMPLETENESS OF ASSEMBLY	A		BRACING	A	
	EQUIPMENT ROTATION	A		LABELING AND TAGGING	A	
	ELECTRICAL/MECHANICAL INTERLOCKS	A		SAFETY INTERLOCKS	A	
	INSTRUMENTS	R		WORKING SPACE	A	
	PROPER GROUNDING	A		ANCHORAGE	A	
	PROPER INSULATION	A		SYSTEM FLUSHED AND CLEANED	R	
	TIGHTNESS OF BOLTED CONNECTIONS	R		COMPARISON TO DRAWINGS	N/A	
	PROPER LUBRICATION	A		CONTROL SYSTEM	A	
	WATER TREATMENT	N/A		FUEL SYSTEM	A	
SECTION D- CALIBRATION AND SET POINT						
21.		DESCRIPTION				NOTES
	SENSORS	Photocell signal level within manufacturers tolerances				
	CONTROLLERS	Fireye controller does not indicate any faults.				1
	ACTUATORS	Burner Modulating Motor operating range appears to be OK. See note.				2
	RELIEF VALVES CHECKED	Relief valve was manually forced open during operation.				3
	FUEL SAFETY VALVES	Gas Train safeties were checked. All safeties functioned appropriately.				
SECTION E- HYDRONIC SYSTEM TESTS						
22.		OPERATING MODES	TEMPERATURES	PRESSURES	FLOWS	LEVELS
	BOILER	Auto	300 degrees F	15 psi	NA	
	PUMP	Auto	190 degrees F	15 psi	NA	
	HYDROSTATIC TEST	performed annually				
	BALANCE TEST	NA				
	HEATING COIL NUMBER	NA				
	CONTROL VALVES	NA				
	SYSTEM TEST	performed annually				
23. NOTES						
1. Boiler is cycling as would be expected.						
2. Operating range checked through the purge cycle, low fire, and high fire positions.						
3. Steam relieved as expected and the valve reseated after the manually applied pressure was removed.						
* CONDITION: A=ACCEPTABLE; R=NEEDS REPAIR, REPLACEMENT OR ADJUSTMENT; C= CORRECTED; NA= NOT APPLICABLE						

Figure 4-3 HVAC Inspection Checklist

CHILLED WATER SYSTEM INSPECTION CHECKLIST						
SECTION A - CUSTOMER DATA						
1. PLANT East Building		2. LOCATION Washington, DC		3. JOB NUMBER EB-19		
4. EQUIPMENT Carrier System		5. COOLING WATER LOOP DESIGNATION		6. DATE (YYYYMMDD) 20021125		
7. TEST EQUIPMENT				8. TESTED BY Roger Swanson		
SECTION B - EQUIPMENT DATA						
9. CHILLER MANUFACTURER Carrier		10. MODEL NO 19XR		11. SERIAL NO 9210H6115		12. BTU RATING 4254 kW
13. PUMP MANUFACTURER Cummins - Wagner		14. MODEL NO 6BC		15. SERIAL NO 1510		16. RATED FLOW 1,898 gpm
17. HP @ RPM 40 @ 1770		18. RATED NPSH 5.5		19. RATED PRESSURE 165 kPa		
SECTION C - VISUAL AND MECHANICAL INSPECTION						
20.	CHECKPOINT	COND*	NOTES	CHECKPOINT	COND*	NOTES
	EXTERIOR OF EQUIPMENT	R		EQUIPMENT IDENTIFICATION	A	
	COMPLETENESS OF ASSEMBLY	A		BRACING	A	
	EQUIPMENT ROTATION	A		LABELING AND TAGGING	A	
	ELECTRICAL MECHANICAL INTERLOCKS	A		SAFETY INTERLOCKS	A	
	INSTRUMENTS	R		WORKING SPACE	A	
	PROPER GROUNDING	A		ANCHORAGE	A	
	PROPER INSULATION	A		SYSTEM FLUSHED AND CLEANED	R	
	TIGHTNESS OF FLITED CONNECTIONS	R		COMPARISON TO DRAWINGS	NA	
	PROPER LUBRICATION	A		CONTROL SYSTEM	A	
	REFRIGERANT INSTALLED	NA		WATER TREATMENT INSTALLED	A	
SECTION D - CALIBRATION AND SET POINT						
21.	DESCRIPTION					NOTES
	SENSORS					Pressure, temperature, and condition sensors checked OK
	CONTROLLERS					Carrier control system interfaces with JCI system.
	ACTUATORS					Exercise annually for valve control.
	RELIEF VALVES CHECKED					Exercise annually for valve operation limits.
SECTION E - HYDRONIC SYSTEM TESTS						
22.	OPERATING MODES	TEMPERATURES	PRESSURES	FLOWS	LEVELS	NOTES
	CHILLER	Auto				
	PUMP	Auto				
	HYDROSTATIC TEST	performed annually				
	BALANCE TEST	NA				
	COOLING COIL NUMBER	NA				
	EXPANSION TANK/AIR SEPARATOR	NA				
	CONTROL VALVES	NA				
	SYSTEM TEST	performed annually				
23. NOTES						
*CONDITION: A=ACCEPTABLE; R=NEEDS REPAIR/REPLACEMENT; C=ADJUSTMENT; O=OCCURRED; NA=NOT APPLICABLE						

Figure 4-4 Chilled Water System Inspection Checklist

VENTILATION SYSTEM INSPECTION CHECKLIST						
SECTION A - CUSTOMER DATA						
1. PLANT East Building		2. LOCATION Washington, DC		3. JOB NUMBER EB-41		
4. EQUIPMENT		5. AIR LOOP DESIGNATION Section C		6. DATE (YYYYMMDD) 20021204		
7. TEST EQUIPMENT Air flow meter, electrical meter, temperature meter				8. TESTED BY Roger Swanson		
SECTION B - EQUIPMENT DATA						
9. FAN MANUFACTURER Greenheck		10. MODEL NO G-120-B	11. SERIAL NO 73662		12. RATED FLOW 980 cfm	
13. FAN TYPE Centrifugal		14. HP @ RPM 1 hp @ 1200		15. RATED PRESSURE 125 static		
SECTION C - VISUAL AND MECHANICAL INSPECTION						
16.	CHECKPOINT	COND*	NOTES	CHECKPOINT	COND*	NOTES
	EXTERIOR EQUIPMENT	A		EQUIPMENT IDENTIFICATION	A	
	COMPLETENESS OF ASSEMBLY	A		BRACING	A	
	EQUIPMENT ROTATION	A		LABELING AND TAGGING	R	
	ELECTRICAL MECHANICAL INTERLOCKS	A		SAFETY INTERLOCKS	A	
	INSTRUMENTS	A		WORKING SPACE	A	
	PROPER GROUNDING	A		ANCHORAGE	A	
	PROPER INSULATION	A		SYSTEM CLEANED	A	
	TIGHTNESS OF ELCTED CONNECTIONS	A		COMPARISON TO DRAWINGS	R	
	PROPER LOCATION	A		CONTROL SYSTEM	R	
	CONDENSATE DRIP PANS	A		FILTERS	R	
SECTION D - CALIBRATION AND SET POINT						
17.		DESCRIPTION				NOTES
	SENSORS	Checked sensors with standard				
	CONTROLLERS	Cycled controllers for response				
	ACTUATORS	Checked full operation from fully open to fully closed				
	FIRE DAMPERS CHECKED	Actuated fire dampers. Checked for proper operation.				
	SMOKE DAMPERS CHECKED	Actuated smoke dampers. Checked for proper operation.				
SECTION E - SYSTEM TESTS						
18.		OPERATING SPEEDS	TEMPERATURES	PRESSURES	FLOWS	LEVELS
	FAN	Speeds as required	68 to 72 F	.125	980	
	DUCT LEAK TEST	On at high speed		.125	980	
	AIR BALANCE TEST	As required	68 to 72 F	.125	980	
	COIL NUMBER	On	68 to 72 F	.125	980	
	COIL NUMBER	On	68 to 72 F	.125	980	
	CONTROL DAMPERS	Moderation of flow	NA	NA	NA	
	SYSTEM TEST	Normal operation	68 to 72 F	NA	NA	
19. NOTES						
* CONDITION: A=ACCEPTABLE R=NEEDS REPAIR/REPLACEMENT C=ADJUSTMENT; O=CORRECTED; NA=NOT AFFLIABLE						

Figure 4-5 Ventilation System Inspection List

Table 4-1 Possible failure and correction actions of HVAC system

	Areas to Check
General Controls	
Devices will not close/trip	Check mechanical alignment of limit switches Check interlocks and safeties Check relay and protective device settings and operation Check for mis-wired circuits Check control circuit Check controller set point
Devices trip inadvertently	Check relay and protective device settings and operation Check for mis-wired circuits Check the control circuit Check for system overload or short Check grounds
Boiler	
Will not start or starts but shuts down	Check PLC Check power supply Check controls, switches, starters, and disconnects Check controller set points Check sensors, actuators, and indicators Check fuel supply Check fuel safety valves Check fuel filters Check burner flame safety Check igniter Check blower and blower inlet Check heating water pump, flow and control valve Check feed water supply Check safeties and interlocks to fire protection systems
Incorrect heating water temperature	Check controls and set point Check heating water pump, flow and control valve Check for closed shut off valves

Table 4-1 (Continued)

Chiller	
Will not start or shuts down	Check Program Logic Controller (PLC) Check power supply Check controls, switches, starters, and disconnects Check controller set point Check sensors, actuators, and indicators Check refrigerant Check refrigerant heaters Check condenser fans Check heat rejection equipment power, pumps, fans, and controls Check water pump, flow and control valve Check safeties and interlocks to fire protection systems
Incorrect cooling water temperature	Check sensors, controllers and set point, actuator/positioners Check chilled water pump, flow and control valve Check expansion tank and air separator Check for closed shutoff valves
Ventilating Fan	
Will not start or shuts down	Check power supply Check controls, switches, starters, and disconnects Check inlet vane and damper actuators Check filter(s) Check safeties and interlocks to fire protection systems
Vibrates	Check motor and fan bearings Check inlet vane and dampers Check impeller condition Check vibration joints and isolators Check air filter(s)
Valves and Dampers	
Will not move	Check for stuck valve stem or damper shaft Check supply air Check positioner linkage adjustment Check pneumatic signal Check actuator shaft, diaphragm, and spring Check controller and controller set point Check safeties and interlocks to fire protection systems

CHAPTER 5 GENERATORS AND ANCILLARY EQUIPMENT

5-1. Description of generator ancillary equipment, diesel fuel, and lube oil systems

Generators are used to supply primary power, standby power and emergency power. The generators used at most facilities are often powered by diesel engines. This course material will address the ancillary equipment consisting of a typical diesel fuel and lube oil system.

a. Diesel fuel system. A diesel fuel system is shown in figure 5-1, Schematic of a typical diesel fuel system. The system consists of a storage tank, strainer, motor driven pump, filter, expansion tank, heater, day tank, cooler, engine mounted duplex filter and engine mounted pump.

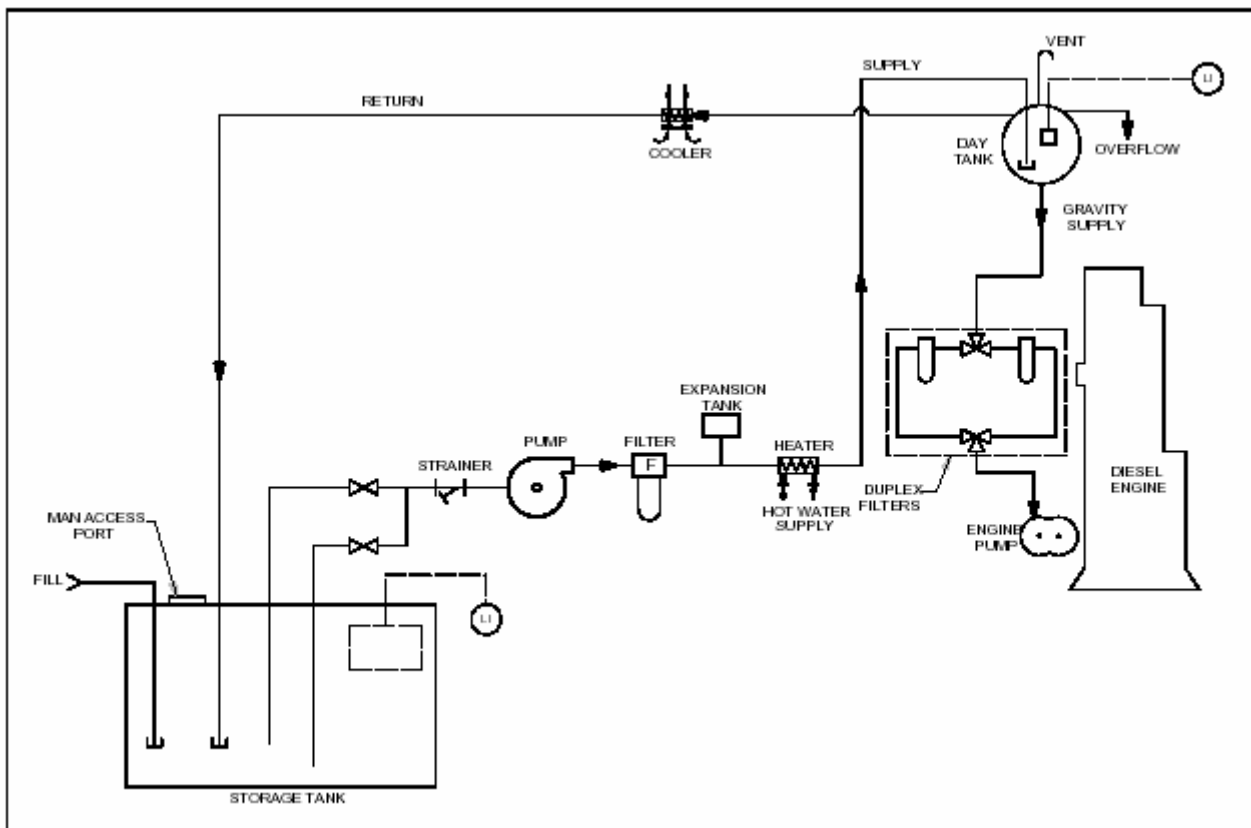

Figure 5-1 Schematic of a typical fuel system

b. Lube oil system. A lube oil system is shown in figure 5-2, Schematic of a typical lube oil system. The system consists of a clean lube oil tank, dirty lube oil tank, pumps, lube heaters, cooler, centrifuge, duplex filter and duplex strainer.

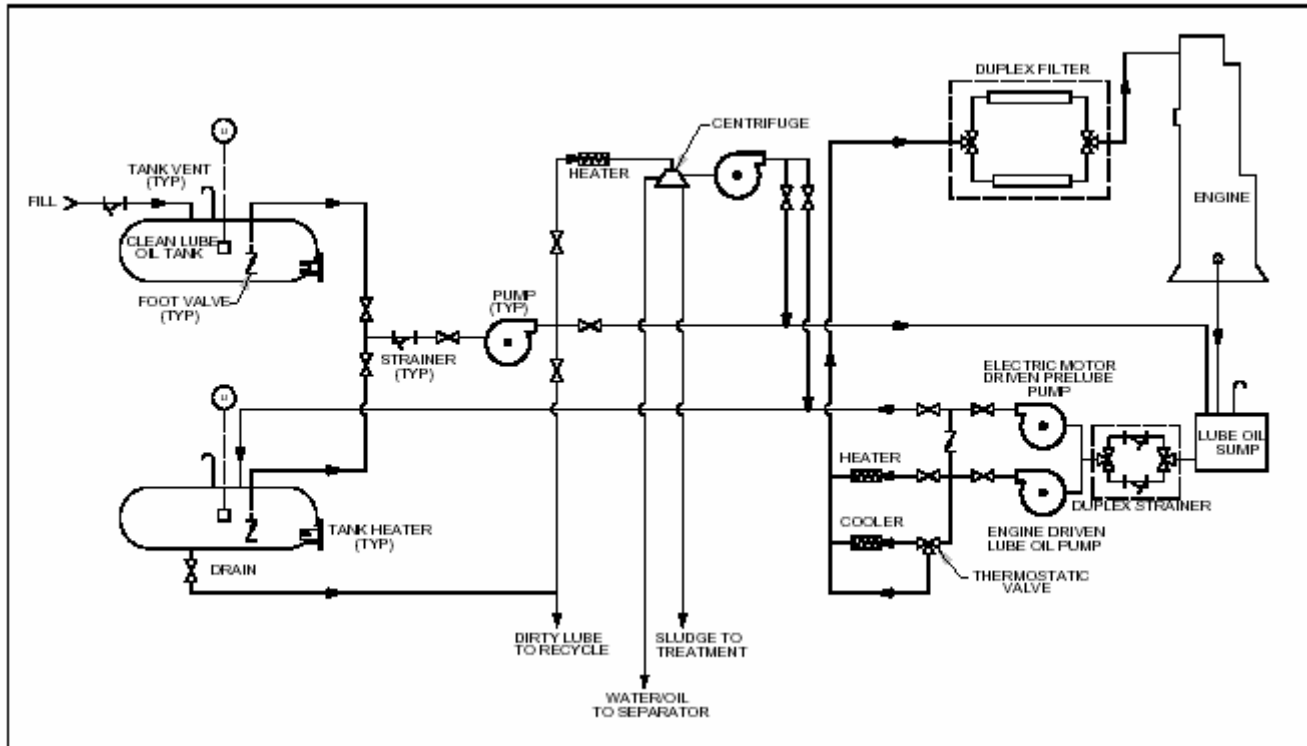

Figure 5-2 Schematic of a typical lube oil system

c. Diesel fuel and lube oil systems. More information on design, maintenance, and testing of diesel fuel and lube oil systems and generators is found in the American Society of Mechanical Engineers (ASME): B 31.3.

5-2. Operation of diesel fuel system and lube oil systems

Basic operations of a diesel fuel and lube oil systems is presented in the following paragraphs.

a. Diesel fuel system operation. The diesel fuel storage tank shown in figure 5-1, Schematic of a typical diesel fuel system, must be a double wall tank or, when located above ground, a single wall tank surrounded by a dike for containment of a leak, can be used. For underground installations, the tank must be double wall with a leak detection system monitoring the annulus between walls. The tank is provided with level indication, either local, remote, and/or is interlocked to shut off fill flow. The tank is provided with a fill line, man access port, return line and two suction lines. The tank may be provided with suction line heaters or a tank heater (not shown) depending on the engine's fuel requirement and type of diesel fuel selected. The fill line and the return lines are provided with traps to minimize the formation of vapors in the tank. One suction line is located higher than the other. Normally the pump will draw from the low suction line. As water separates from the fuel it will approach the lower suction line. If water is picked up in this line, the pump can be switched to the upper suction line until the water is removed through the man access port. A strainer provides a coarse means of particulate removal upstream of the pump. A coalescing filter provides for water and fine particulate removal downstream of the pump. An expansion tank may be installed to prevent expanding fuel oil from leaking from joints and shaft seals. An oil heater may be installed depending on the type of oil and climate, to reduce oil viscosity to atomizing range. The fuel oil then enters the day tank and is discharged through a trap. The day tank holds a four- to eight- hour supply of fuel and is mounted above, or in close proximity to, the generator's diesel engine. It is provided with a vent, overflow, return line, gravity feed line to the duplex engine filters, a pump and a level indication, either local, remote and/or interlocked to shut off supply flow. The engine's positive displacement pump raises the diesel fuel to the correct pressure for engine operation and distributes it

to the fuel injectors. An oil cooler is provided, when needed, in the return line to minimize flashing and formation of vapors. Oil lines may be electrically or steam heat traced for winter service depending on the type of fuel, climate and installed pipe location.

b. Lube oil system operation. As shown in the lube oil system in figure 5-2, Schematic of a typical lube oil system, new lube oil passes through a strainer before entering the clean lube tank. The tank is provided with level indication, either local, remote and/or is interlocked to shut off fill flow. The tank is also equipped with a vent and a heater if required. The dirty lube tank incorporates a drain, level indication, vent, return line and suction line.

- (1) A pump draws lube oil through a strainer and foot valve in either tank. The foot valve prevents the line from emptying when not in use. From this pump, lube oil can flow to the engine lube oil sump, to a tanker truck for hauling to an oil recycle center, or it can be heated and cleaned through a centrifuge. From the centrifuge, water/oil discharge is sent to a separator, sludge is sent to treatment for disposal and the treated lube is sampled. The treated lube if clean is pumped to the engine lube oil sum, or if dirty it is pumped to the dirty lube oil tank.
- (2) From the engine lube oil sump, lube oil is pumped through a duplex strainer by a motor driven pump or an engine driven pump. As with duplex filters, duplex strainers provide for continuous operation. Switching from one strainer to the other can take place without impeding oil flow by switching the inlet and outlet three-way valves simultaneously. This permits cleaning of one strainer while the other is in service. When the standby power engine requires warm engine lube and a warm engine block for startup, the electric motor driven pump continuously circulates engine lube through a heater. Once the engine is started the engine driven lube oil pump will take over and lube will flow through a thermostatic valve to a cooler and by-pass line to maintain correct engine lube temperature for operation. The lube oil flows through a duplex filter before entering the engine. The electric motor driven pump can also be used as a pre-lube pump to circulate lube prior to starting the engine and after the engine shuts down for controlled cooling. The pump also transfers dirty lube from the engine lube oil sump to the dirty lube oil tank.
- (3) The lube oil system may be integral with the engine or may be provided as a separate skid mounted unit. Lube oil tanks, pipes, and lines may be heated or heat traced. Controls, alarms and engine shutdown interlocks are provided as needed and include alarms for low oil flow, low oil level, low oil pressure, low oil temperature, high oil temperature or high filter differential pressure.

5-3. Pre-functional test plan and functional performance test plan for diesel fuel and lube oil systems

This course assumes that individual components and packaged equipment have been tested by the manufacturer. As part of the commissioning effort each component should be checked for damage, deterioration, and failures by a procedure using inspections and tests as defined by the specific equipment manufacturers. Equipment manuals from manufacturers identify the minimum required receipt inspections, handling and installation procedures, drawing and wiring verification, field inspection and installation checks, verification of removal of shipping braces, inspection of installation against drawings and nameplates, inspection of components for damage and cleanliness, inspection of insulators and grounding, inspection of anchorage and alignment, adjustment checks, mechanical operation and interlock checks, lubrication application and verification that local safety equipment is in place.

a. Safety, diesel fuel and lube oil systems. Many tests on equipment involve the use of high voltages, high currents, pressurized fuel and rotating or moving equipment. These can be dangerous to personnel and damaging to equipment. A procedure should be followed to insure adequate safety rules are instituted and

practiced to prevent injury to personnel performing the tests and other personnel who might be in the local area.

b. Test equipment, diesel fuel and lube oil systems. It is important that in any test program the proper equipment is used. The equipment should be calibrated, in good condition, and used by qualified operators as required by a procedure. Any test equipment used for calibration shall have twice the accuracy of the equipment to be tested. All equipment should be operated in accordance with its instruction manual. A procedure defining installation inspection and a system test needs to be provided.

c. Inspection checklists, diesel fuel and lube oil systems. Inspection checklist(s) for fuel oil systems are presented in figure(s) 5-3, and 5-4. They are filled out to serve as examples of typical equipment conditions. For convenience, these checklists are included unpopulated at the end of the course material.

5-4. Possible failures and corrective measures for diesel fuel and lube oil systems

Table 5-1 lists general problems that may arise during the testing of equipment and systems along with possible troubleshooting techniques. For all problems, consult equipment and component manuals for troubleshooting directions. Check fuses/lights/breakers/etc., for continuity, check equipment calibration and settings, check for clogged filters and strainers, check for closed manual shutoff valves and dampers, check for improperly adjusted valves and equipment, and look for faulty equipment and connections.

DIESEL FUEL SYSTEM INSPECTION CHECKLIST					
SECTION A - CUSTOMER DATA					
1. PLANT Redundant Power		2. LOCATION Building 10		3. JOB NUMBER RP-22	
4. EQUIPMENT Fuel Oil System - 1		5. SYSTEM DESIGNATION FOS - 1		6. DATE (YYYYMMDD) 20021125	
7. TEST EQUIPMENT Graduated Story pole, tank level chart, Fluke multimeter				8. TESTED BY Bob Hale	
SECTION B - EQUIPMENT DATA					
9. PUMP MANUFACTURER Oberdorfer		10. MODEL NO N993-03		11. SERIAL NO T10063	
12. FLOW RATING GPM 8 gpm		13. TYPE Gear Pump		14. HP @ RPM NA	
15. PRESSURE RATING PSIG NA		16. HEATER MANUFACTURER		17. MODEL NO NA	
18. SERIAL NO NA		19. FLOW RATE GPM NA		20. COOLER MANUFACTURER	
21. MODEL NO NA		22. SERIAL NO NA		23. FLOW RATE GPM	
SECTION C - VISUAL AND MECHANICAL INSPECTION					
24.	CHECKPOINT	COND*	NOTES	CHECKPOINT	COND*
	EXTERIOR OF EQUIPMENT	A		EQUIPMENT IDENTIFICATION	A
	COMPLETENESS OF ASSEMBLY	A		BRACING	A
	EQUIPMENT ROTATION	A		LABELING AND TAGGING	A
	ELECTRICAL/MECHANICAL INTERLOCKS	A		SAFETY INTERLOCKS	A
	INSTRUMENTS	A		WORKING SPACE	A
	PROPER GROUNDING	A		ANCHORAGE	A
	PROPER INSULATION	NA		LEAKS	A
	TIGHTNESS OF BOLTED CONNECTIONS	A		COMPARISON TO DRAWINGS	NA
	PROPER LUBRICATION	NA		CONTROL SYSTEM	A
SECTION D - CALIBRATION AND SET POINT					
25.		DESCRIPTION			NOTES
	SENSORS	Main tank levels are consistent with sensor reading.			1
	CONTROLLERS	Main tank controllers indicate all conditions normal			
	ACTUATORS	NA			
SECTION E - DIESEL FUEL SYSTEM TESTS					
26.		OPERATING MODES	TEMPERATURES	PRESSURES	FLOW
	PUMP	Auto	55 degrees F	3 psi	8 gpm
	HEATER	NA			
	COOLER	NA			
	ENGINE	NA			
	HYDROSTATIC TEST	NA			
	SYSTEM TEST	performed annually			
27. NOTES 1. Tank level was taken with Story pole and calculated using tank chart.					
*CONDITION: A=ACCEPTABLE R=NEEDS REPAIR/REPLACEMENT C=ADJUSTMENT; G=CORRECTED; NA=NOT APPLICABLE					

Figure 5-3 Diesel Fuel System Inspection Check List

LUBE OIL SYSTEM INSPECTION CHECKLIST						
SECTION A - CUSTOMER DATA						
1. PLANT East Building		2. LOCATION Washington, DC		3. JOB NUMBER EB--13		
4. EQUIPMENT		5. SYSTEM DESIGNATION		6. DATE (YYYYMMDD) 20021126		
7. TEST EQUIPMENT Fluke calibrated multimeter, pressure gauge				8. TESTED BY Roger Swanson		
SECTION B - EQUIPMENT DATA						
9. PUMP MANUFACTURER Oberdorfer		10. MODEL NO N993		11. SERIAL NO 7580		12. FLOW RATING GPM 2 gpm
13. TYPE Gear Pump		14. HP @ RPM .5 @ 1800		15. PRESSURE RATING PSIG 40 psig		
16. HEATER MANUFACTURER NA		17. MODEL NO		18. SERIAL NO		19. FLOW RATING GPM
20. COOLER MANUFACTURER NA		21. MODEL NO		22. SERIAL NO		23. FLOW RATING GPM
24. CENTRIFUGE MANUFACTURER RCI		25. MODEL NO R/C - 1500		26. SERIAL NO 0954KJ9		27. FLOW RATING GPM 150 gpm
SECTION C - VISUAL AND MECHANICAL INSPECTION						
28.	CHECKPOINT	COND*	NOTES	CHECKPOINT	COND*	NOTES
	EXTERIOR OF EQUIPMENT	A		EQUIPMENT IDENTIFICATION	A	
	COMPLETENESS OF ASSEMBLY	A		BRACING	A	
	EQUIPMENT ROTATION	A		LABELING AND TAGGING	A	
	ELECTRICAL MECHANICAL INTERLOCKS	A		SAFETY INTERLOCKS	A	
	INSTRUMENTS	A		WORKING SPACE	A	
	PROPER GROUNDING	A		ANCHORAGE	A	
	PROPER INSULATION	A		LEAKS	A	
	TIGHTNESS OF BOLTED CONNECTIONS	A		COMPARISON TO DRAWINGS	A	
	PROPER LUBRICATION	A		CONTROL SYSTEM	A	
SECTION D - CALIBRATION AND SET POINT						
29.		DESCRIPTION				NOTES
	SENSORS	Level and pressure sensors in both day and storage tanks OK				
	CONTROLLERS	Simplex control system OK				
	ACTUATORS	Fuel control valves activated fully for fuel transfer				
SECTION E - LUBE SYSTEM TESTS						
30.		OPERATING MODES	TEMPERATURES	PRESSURES	FLOWS	LEVELS
	PUMP	Auto	NA	40 psig	2 gpm	
	HEATER	NA				
	COOLER	NA				
	ENGINE	Auto	195 degrees F	NA	NA	
	HYDROSTATIC TEST	NA				
	SYSTEM TEST	performed monthly				
31. NOTES						
* CONDITION: A=ACCEPTABLE; R=NEEDS REPAIR; REPLACEMENT OR ADJUSTMENT; C=CORRECTED; NA=NOT AFFLUABLE						

Figure 5-4 Lube Oil System Inspection Checklist

Table 5-1 Possible Failures and Corrective Actions for Diesel Oil and Lube Oil Systems

	Areas to Check
General Controls	
Devices will not close/trip	<ul style="list-style-type: none"> Check mechanical alignment of limit switches Check interlocks and safeties Check relay and protective device settings and operation Check for mis-wired circuits Check control circuit Check controller set point
Devices trip inadvertently	<ul style="list-style-type: none"> Check relay and protective device settings and operation Check for mis-wired circuits Check the control circuit Check for system overload or short Check grounds
Diesel Fuel System	
Will not start or starts but shuts down	<ul style="list-style-type: none"> Check power supply Check controls, switches, starters, and disconnects Check controller set points, temperatures, pressures, levels Check sensors, actuators, and indicators Check heaters Check filters Check fuel level and fuel quality Check safeties and interlocks to fire protection systems
Incorrect fuel flow or no fuel flow	<ul style="list-style-type: none"> Check pumps Check controls and set point Check filters Check for closed shut off valves Check safeties and interlocks to fire protection systems
Lube Oil System	
Will not start or shuts down	<ul style="list-style-type: none"> Check power supply Check controls, switches, starters and disconnects Check controller set points, temperatures, pressures, levels Check sensors, actuators and indicators Check filters Check lube oil level Check safeties and interlocks
Incorrect lube oil flow or no lube oil flow	<ul style="list-style-type: none"> Check pumps Check centrifuge Check controls and set point Check heaters Check filters Check for closed shut off valves Check safeties and interlocks to fire protection systems

CHAPTER 6 AIR COMPRESSORS AND PNEUMATIC CONTROL SYSTEMS

6-1. Description of compressed air and pneumatic control systems

Compressed air is used in many operations and processes and as a source of energy for heating, ventilating and air conditioning (HVAC) and process actuators and motors. It is also use as low pressure systems and for pneumatic control. Air can be compressed in several different ways and supplied at varying pressures and degrees of filtration depending on its use. Paragraph 6-3, General compressed air equipment description and operation, explains the operation of various types of compressors and dryers.

a. Compressed air system. A typical compressed air system is shown in figure 6-1, Schematic of a typical compressed air system. The system is capable of producing instrument quality air for pneumatic HVAC controls, tools, conveying systems and general plant air. The system consists of a single motor driven single stage rotary screw compressor with inlet air filter, a safety relief valve, aftercooler, air/oil separator, air receiver with safety relief valve, prefilter, air dryer, afterfilter, oil/water traps and oil/water separator.

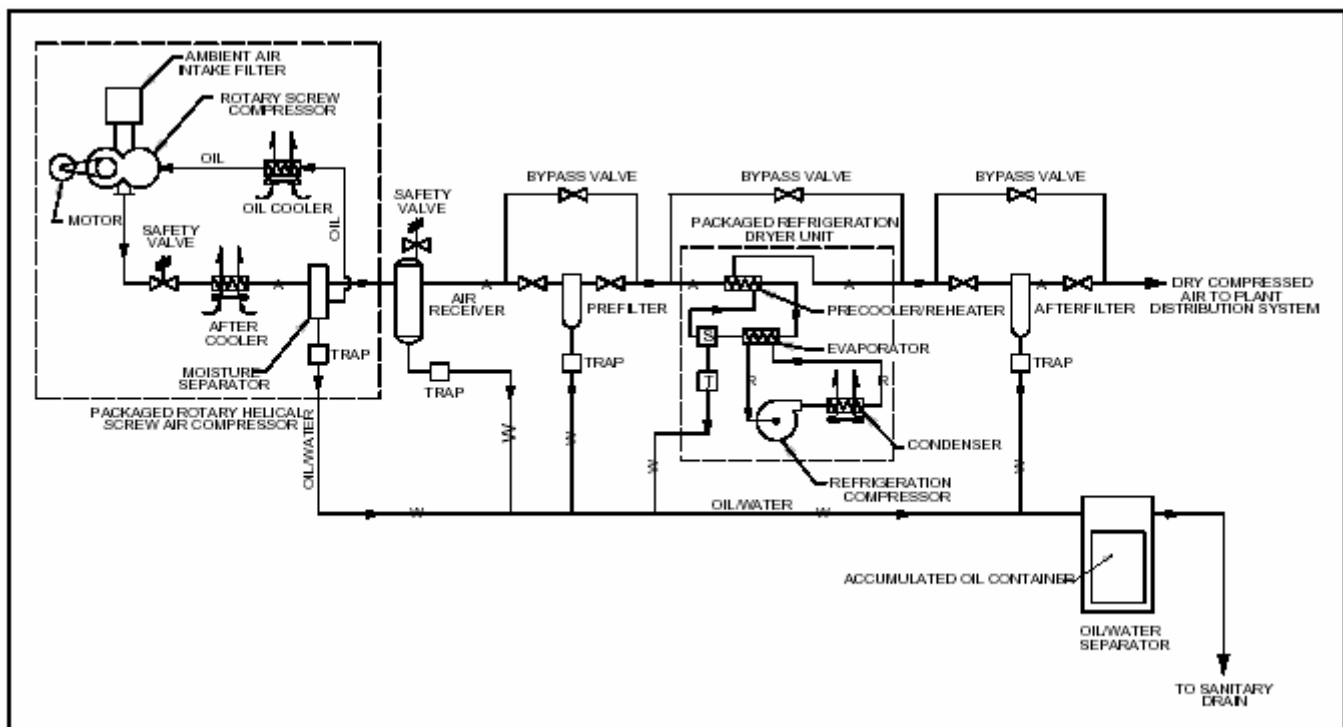

Figure 6-1 Schematic of a typical compressed air system

b. Pneumatic control system. For a description of a pneumatic control system refer to chapter 4, Heating, ventilating, and air-conditioning (HVAC) equipment and controls, paragraph 4-1, Description of HVAC systems.

c. Compressed air and pneumatic control systems. More information on design, maintenance, and testing of compressed air systems is found in the American Society of Mechanical Engineers (ASME): B19.1 Safety standard for air compressor systems, B31.1 Power piping, and Chapter 8. Boiler and pressure vessels.

6-2. Operation of compressed air systems

Refer to figure 6-1, Schematic of a typical compressed air system. Ambient air is pulled through a 5 to 10 micron filter and compressed by the helical rotors of the rotary screw compressor. A safety relief valve is installed in the discharge line and set at the design pressure of the system. The compressed air flows through an after cooler to remove the heat of compression. The compressed air temperature is reduced to within 15 to 20°F of ambient in the aftercooler.

a. The air next flows through a moisture/air separator. This separator removes most of the oil. The oil is cooled and returned to the compressor where it provides sealing, lubrication, and some cooling. From the moisture separator a mixture of condensation water and oil is discharged through a trap to an oil/water separator. This separator removes oil from the condensate down to 2 parts per million (ppm) so that it can be discharged to a sanitary sewer. The oil is accumulated in a filter or collection container, is usually considered hazardous waste and must be properly disposed of.

b. The air may now flow to a receiver with a safety relief valve. Not all compressed air systems incorporate a receiver. The needs of process equipment and the type and size of the compressors determine the need for a receiver. The receiver provides a cushion for compressed air pulses when a reciprocating compressor is used, a storage volume of air to handle peaks of high usage and a storage volume of air to allow operation of systems during periods of power loss. Receivers usually provide one gallon of capacity for each cubic foot of flow. A liquid trap discharges accumulated condensate and oil to the oil/water separator.

c. Downstream of the receiver a prefilter may be installed followed by a dryer and an afterfilter. All of these devices are provided with shutoff valves upstream and downstream and a bypass valve to allow servicing. These devices also are supplied with traps which allow accumulated condensate/oil mixtures to be processed in the oil/water separator. There are several different types of dryers. The most common is a refrigerant dryer, as presented in the typical system. In this dryer a refrigerant cycle cools the compressed air temperature down to about 33 to 40°F. The water content of the cool air is much less than that of hot air. The air is considered dry at this point. Other types of dryers can lower air temperature further for special process requirements. Refrigerant dryers are sufficient for HVAC control systems.

The afterfilter removes moisture from the air stream down to 0.5 ppm and filter particulate down to 1 micron. Finer filters can be installed if required by the operating process. Drip legs should be provided in the piping system header and branch lines to collect condensate and should include a trap. The header should be supplied from both ends thereby making a loop of compressed air around the building. Branch lines should be tapped from the top of header lines to prevent condensate and rust accumulation from entering the line. Lines should be sloped toward drip legs.

6-3. General compressed air equipment description and operation

Compressed air systems can use multi-stage compressors and/or provide multi-compressor installations with or without multiple coarse to fine filters depending on process needs. Following is some of the equipment used in various combinations in compressed air systems. A description of the equipment and its operation is provided below.

a. Air compressor types. Compressors are most often supplied skid mounted as a packaged unit. The assembled package includes all major components, controls and a sound attenuation enclosure. The unit only requires mounting to a foundation, hook up to system piping, connection to the oil/water separator and power connection. Following is a discussion of various types of compressors.

- (1) Rotary helical screw air compressors are positive displacement machines. A twin-screw compressor consists of accurately matched rotors [one lobe (male) and one helix (female)] that mesh closely when

rotating within a close tolerance common housing. One rotor is motor driven while the other is gear driven, turning it in a counter-rotating motion. The rotors uncover inlet posts at one end allowing air to flow in. As the rotors continue to rotate the air is compressed by the diminishing volume between the rotors. At the end of the rotors, ports allow the now compressed air to exit. One or more stages may be used. These compressors are used in systems up to 3000 cubic feet per minute (cfm). They are usually oil injected to increase sealing, lubricate rotors and provide cooling. They can also be oil free. One or two stages can be used. They have a low initial cost, no pulsation, are almost free of vibration and do not require special foundations.

- (2) Centrifugal compressors compress air as it enters the center of a fluted casting, housing a rotating impeller. The impeller imparts kinetic energy to the gas which turns into potential energy as the gas velocity slows, thus increasing pressure. Compression is a continuous process. One or more stages may be used. Centrifugal compressors are used in large systems up to 18,000 cfm. A blow-off silencer is needed to control noise. Centrifugal compressors require no lubrication in contact with the air stream and therefore provide oil free air.
- (3) Reciprocating or positive displacement compressors use a piston in a cylinder to compress air up to a capacity of 6,000 cfm. Air enters the cylinder through a valve when the piston is going down. The valve closes when the piston starts to go up. As the piston approaches the top of the cylinder, the air is compressed by the decreasing volume. An exhaust valve opens when the piston is near the top of the cylinder allowing the compressed air to exit. The cycle is then repeated. These compressors can be specially constructed to operate as oil free. One or more stages can be used. Multiple stages are used with inter-cooling between stages in large applications. Because of their reciprocating mass they pulsate, vibrate, create harmonics in piping systems and, for larger sizes, require special foundations and special noise attenuation.
- (4) Rotary sliding vane compressors use a rotor eccentrically mounted in a cylinder. The rotor has eight or more slots cut along its length. Vanes are placed in the slots. As the rotor rotates, the vanes move out from centrifugal force. As the rotor continues through a rotation, the rotor housing causes the vanes to move back in the slot of the rotor. The volume of air between the housing, eccentrically mounted rotor, and two vanes changes as the rotor rotates, compressing the air. An outlet port is located in the housing where the rotor is closest to it. An inlet port is located just past the outlet port. One or more stages may be used. These compressors are used in systems up to 3000 cfm. They can be oil injected or oil free. One or two stages can be used. They have a low operating cost, no pulsation, are free of vibration, and do not require special foundations.

b. Dryers. Compressed air dryers are most often supplied skid mounted as a packaged unit. The assembled package includes all major components and controls mounted and pre-wired, requiring only that they be anchored to a foundation, hooked up to the compressed air piping system and oil/water separator and connected to power. Following is a discussion of various compressed air dryers.

- (1) Refrigerant dryers use a refrigeration cycle to cool the compressed air down to 33°F as a minimum. Below this temperature the condensate will freeze and stop air flow. This type of dryer has a low initial cost, low operating cost and is inherently reliable. It is the most common type of dryer used for plant air, air operated tools, pneumatic instrumentation for HVAC systems and material conveying.
- (2) Regenerative dryers using desiccant to dry compressed air, can dry air to minus 150°F. Twin towers of moisture adsorbing desiccant are used. One is in operation while the other is being regenerated with a heat source or compressed air. Initial cost varies from low to high and operating costs vary from moderate to high. These dryers are used where very dry air is needed.

- (3) Deliquescent dryers use an absorbent material and can only dry air to a maximum of 20°F below inlet temperature. The moisture and absorbent react and form a liquid which is drained from the dryer. The effluent is corrosive, must be disposed of as a hazardous material and carryover into the system may be possible, causing maintenance problems downstream. These problems along with minimal moisture removed reduce the attractive low initial cost and low to moderate operating cost of the system.

6-4. Pre-functional test plan and functional performance test plan for compressed air systems

This course assumes that individual components and packaged equipment have been tested by the manufacturer. As part of the commissioning effort each component should be checked for damage, deterioration, and failures by a procedure using inspections and tests as defined by the specific equipment manufacturers. Equipment manuals from manufacturers identify the minimum required receipt inspections, handling and installation procedures, drawing and wiring verification, field inspection and installation checks, verification of removal of shipping braces, inspection of installation against drawings and nameplates, inspection of components for damage and cleanliness, inspection of insulators and grounding, inspection of anchorage and alignment, adjustment checks, mechanical operation and interlock checks, lubrication application and verification that local safety equipment is in place.

a. Safety, compressed air system. Many tests on equipment involve the use of high voltages, high currents, pressurized air, pressurized gas and rotating or moving equipment. These can be dangerous to personnel and damaging to equipment. In addition, compressed air systems employ safety valves which must be properly installed, vented and the relief pressure must be properly set. A procedure should be followed to insure adequate safety rules are instituted and practiced to prevent injury to personnel performing the tests and other personnel who might be in the local area.

b. Test equipment, compressed air system. It is important that in any test program the proper equipment is used. The equipment should be calibrated, in good condition and used by qualified operators as required by a procedure. Any test equipment used for calibration shall have twice the accuracy of the equipment to be tested. All equipment should be operated in accordance with its instruction manual. A procedure defining installation inspection and a system test needs to be provided.

c. Inspection checklist, compressed air system. An inspection checklist for the system is presented in figure 6-2, compressed air system inspection checklist. It is filled out to serve as an example of typical equipment conditions. For convenience, this checklist is included unpopulated at the end of this course material.

6-5. Possible failures and corrective measures for compressed air systems

Table 6-1 lists general problems that may arise during the testing of equipment and systems along with possible troubleshooting techniques. For all problems, consult equipment and component manuals for troubleshooting directions. Check fuses/lights/breakers/etc. for continuity, check equipment calibration and settings, check for clogged filters and strainers, check for closed manual shut off valves and dampers, check for improperly adjusted valves and equipment and look for faulty equipment and connections.

COMPRESSED AIR SYSTEM INSPECTION CHECKLIST						
SECTION A - CUSTOMER DATA						
1. PLANT West Building		2. LOCATION Arlington, VA		3. JOB NUMBER WB - 34		
4. EQUIPMENT Ingersol Rand		5. SYSTEM DESIGNATION		6. DATE (YYYYMMDD) 20021126		
7. TEST EQUIPMENT				8. TESTED BY Roger Swanson		
SECTION B - EQUIPMENT DATA						
9. COMPRESSOR MANUFACTURER Ingersol Rand		10. MODEL NO 7100E15V	11. SERIAL NO 67-95863		12. FLOW RATING CFM 50 cfm @ 175 psi	
13. TYPE Reciprocating		14. HP @ RPM 15 @ 1750		15. PRESSURE RATING PSIG 175 psig		
16. DRYER MANUFACTURER		17. MODEL NO		18. SERIAL NO		
19. EXIT FLOW RATE @ DP F		20. CIL WATER SEPARATOR MFG		21. MODEL NO		
22. SERIAL NO		23. FLOW RATE CFM 19 cfm				
SECTION C - VISUAL AND MECHANICAL INSPECTION						
24. CHECKPOINT	COND*	NOTES	CHECKPOINT	COND*	NOTES	
EXTERIOR OF EQUIPMENT	A		EQUIPMENT IDENTIFICATION	A		
COMPLETENESS OF ASSEMBLY	A		BRACING	A		
EQUIPMENT ROTATION	A		LABELING AND TAGGING	A		
ELECTRICAL MECHANICAL INTERLOCKS	A		SAFETY INTERLOCKS	A		
INSTRUMENTS	A		WORKING SPACE	A		
PROPER GROUNDING	A		ANCHORAGE	A		
PROPER INSULATION	A		CONDENSATE DRIP LINES	A		
TIGHTNESS OF BOLTED CONNECTIONS	A		COMPARISON TO DRAWINGS	A		
PROPER LABELING	R		CONTROL SYSTEM	A		
SECTION D - CALIBRATION AND SET POINT						
25.	DESCRIPTION				NOTES	
SENSORS	NA					
CONTROLLERS	Pressure control set on at 90psi, off at 115 psi.					
ACTUATORS	NA					
RELIEF VALVES CHECKED	Pressure relief set at 125 psi.				I.	
SECTION E - COMPRESSED AIR SYSTEM TESTS						
26.	OPERATING MODES	TEMPERATURES	PRESSURES	FLOWS	LEVELS	NOTES
AIR COMPRESSOR	Auto	130 degrees F	100 psi	NA		
AIR DRYER	Auto	60 degrees F	65 psi	10 scfm		
CIL WATER SEPARATOR	Clean	NA	65 psi	NA		
PRESSURE TEST	NA	NA	NA	NA		
FILTERS, TRAPS	Clean	NA	65 psi			
SYSTEM TEST	NA					
27. NOTES 1. Pressure relief actually lifted at 130 psi per tank gauge.						
* CONDITION: A=ACCEPTABLE; R=NEEDS REPAIR, REPLACEMENT OR ADJUSTMENT; C=CORRECTED; NA=NOT APPLICABLE						

Figure 6-2 Compressed Air System Inspection Checklist

Table 6-1 Possible Failures and Corrective Actions for Compressed Air System(s)

	Areas to Check
General Controls	
Devices will not close/trip	<ul style="list-style-type: none"> Check mechanical alignment of limit switches Check interlocks and safeties Check relay and protective device settings and operation Check for mis-wired circuits Check control circuit Check controller set point
Devices trip inadvertently	<ul style="list-style-type: none"> Check relay and protective device settings and operation Check for mis-wired circuits Check the control circuit Check for system overload or short Check grounds
Compressor	
Will not start or starts but shuts down	<ul style="list-style-type: none"> Check PLC Check power supply Check controls, switches, starters, and disconnects Check controller set points, temperatures, pressures, levels Check sensors, actuators, and indicators Check filters Check oil level Check safeties and interlocks to fire protection systems Check condensate/oil trap
Incorrect air pressure or no air flow	<ul style="list-style-type: none"> Check compressor Check controls and set point Check filters Check for closed shut off valves Check safeties and interlocks to fire protection systems
Dryer	
Will not start or shuts down	<ul style="list-style-type: none"> Check PLC Check power supply Check controls, switches, starters, and disconnects Check controller set point Check sensors, actuators, and indicators Check refrigerant Check refrigerant heaters Check condenser fan Check safeties and interlocks
Wet compressed air supply	<ul style="list-style-type: none"> Check dryer condensate trap Check compressor condensate trap Check receiver condensate trap Check dryer sensors, controllers, and set point Check for closed drain valves
Oil/Water Separator	
Will not operate or shuts down	<ul style="list-style-type: none"> Check air or electric power supply Check controls, float levels, switches, starters, and disconnects Check drains and traps Check oil container/filter Check safeties and interlocks

**CHAPTER 7
FIRE FIGHTING AND SUPPRESSION SYSTEMS**

7-1. Description of wet pipe sprinkler systems and fire detection systems

Fire protection in a facility includes architectural, mechanical, and electrical considerations. Provisions for egress by locating exit doors within limited walking distances, fire walls, fire doors, the location of fire extinguishers and mechanical fire suppression systems which may or may not be interlocked with electrical fire detection and alarm systems are some of the ways personnel, facilities and equipment can be protected from fire. An early warning fire detection system is designed to detect fire, warn personnel through alarms and release extinguishing agents. There are various types of fire fighting suppression systems and detection systems. Most of these are discussed in this chapter.

a. Wet pipe sprinkler system. The typical wet pipe sprinkler system includes city water supply, drain lines, fire riser consisting of shutoff valves, check valves, an alarm check valve, fire department connection, water motor driven alarm, branch lines, fusible link sprinkler heads, vent and low point drain, tamper switches and post indicator valves.

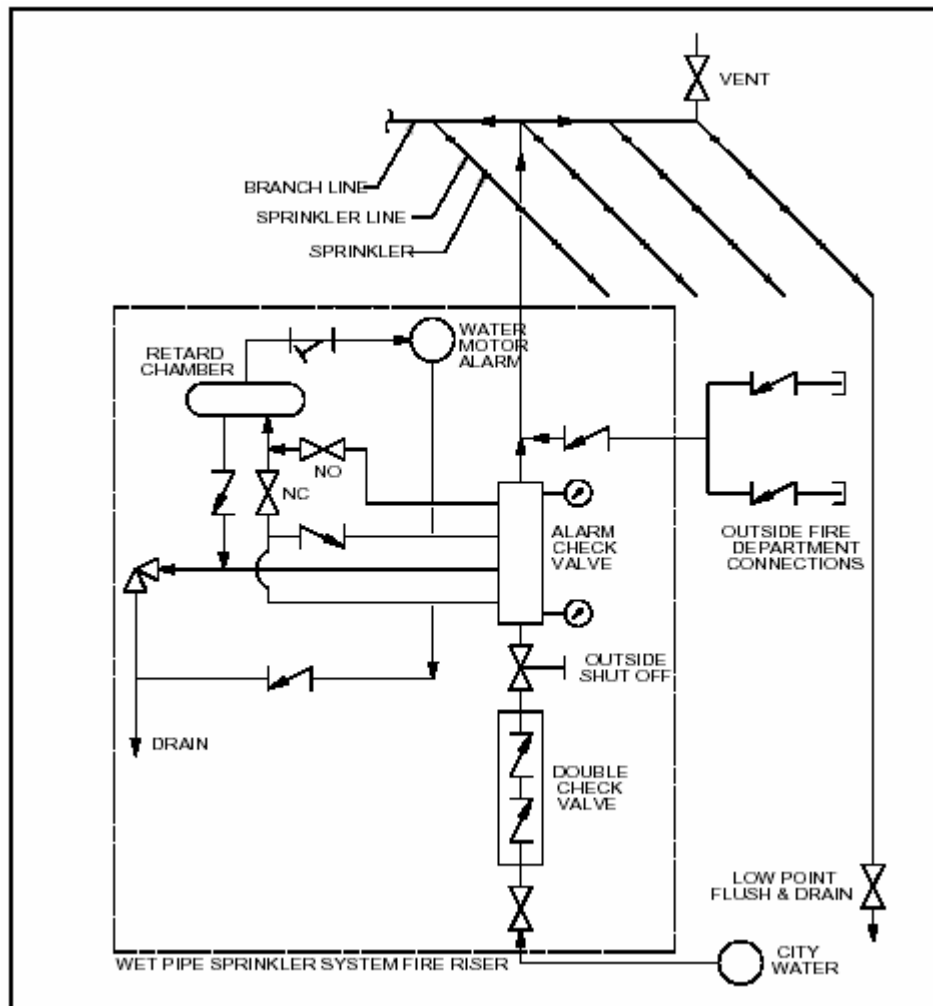

Figure 7-1 Typical Wet Pipe Sprinkler System

b. Fire detection system. Discussed in this manual is a typical fire detection system. The fire detection system consists of smoke detectors, heat detectors, pull stations, alarm/strobe lights, tamper switches, flow switch, control panel and backup power supply.

c. Wet pipe sprinkler system and fire detection system. More information on design, maintenance and testing of fire fighting and suppression systems is found in the National Fire Protection Association (NFPA) Standard 12, Carbon dioxide extinguishing systems, Standard 13, Installation of sprinkler systems, and Standard 72, National fire alarm code, NFPA 25 Standard for the Inspection, Testing and Maintenance of Water Based Fire Protection Systems.

7-2. Operation of wet pipe sprinkler systems and fire detection systems

Operation of the typical wet pipe sprinkler system and a fire detection system are discussed in the following paragraphs.

a. Wet pipe sprinkler system operation. From figure 7-1 it can be seen that city potable water serves as the source for fire water. A shutoff valve is provided in the fire riser just inside and above the building floor. Above the shutoff valve is a double check valve installed to prevent back flow into the city water system. This valve is followed by a shutoff valve with outside access having an indicator to indicate whether it is open or closed. The valve is normally open with a chain and padlock applied to prevent tampering. A tamper switch is also installed to sound an alarm if and when the valve is tampered with by unauthorized personnel. Above this valve is an alarm check valve which permits flow to the sprinkler system and has connections for a drain, pressure gages and the retard chamber which operates the water flow motor driven alarm placed outside of the building. Test connections, shutoff valves, check valves, vents and drains are located as required to flush and test various components of the system on a schedule established with NFPA 25: Standard for the Inspection, Testing and Maintenance of Water Based Fire Protection Systems. One leg of the tee allows fire water to be provided by a set of fire department connections located outside of the building. A check valve is incorporated to prevent backflow through the fire department connection. The fire department connections are redundant to the city water supply and provide another source of water for the wet pipe sprinkler system. The riser then connects to branch lines which serve sprinkler lines. In the sprinkler lines are fusible link sprinkler heads located as required by the NFPA, local codes and the insurance company. The fuse is usually chosen to melt at 135oF, however other temperatures are available. The number, type and location of sprinkler heads is determined by the fire occupancy rating. This rating considers the type of structure, the materials present in the area, the number of personnel and the liability resulting from a fire. In the wet pipe system, heat from a fire will melt the fuse in the sprinkler allowing water to flow from that head. The purpose of the water is to slow the fire until professional fire fighting assistance can arrive. Also provided in the sprinkler lines are a high point vent and a drain at the far end of the system. The vent allows the system to relieve air to assist with draining the sloped sprinkler and branch lines and to assist in filling the system with water. The drain at the far end of the system permits verification of water flow and flushing of the system.

b. Fire detection system operation. The fire detection system uses smoke detectors and heat detectors to detect fire in a facility. Heat detectors are either fixed temperature or rate-of-rise. Fixed temperature detectors are activated when the sensor inside the detector reaches a set temperature. This temperature is normally 135oF for common areas and 195oF for mechanical or boiler type rooms. Rate-of-rise detectors are activated when temperature rises to a set temperature within a set period of time. An electrical signal interruption from these detectors, pull stations, tamper switches on fire riser valves and/or flow switch on the fire riser is interpreted by the control panel and processed. The panel will activate local alarm/strobe lights mounted inside and outside of the facility, and an alarm at the fire department. The panel face displays the location and type of sensor which sent off the alarm. The backup power supply includes a solid-state automatic switch, battery and charger.

7-3. General fire fighting and suppression system equipment description and operation

A description and operation of different types of fire suppression components and systems and fire detection components is presented in the following paragraphs.

a. Dry pipe sprinkler system. Dry pipe sprinkler systems have heat operated fusible sprinkler heads similar to a wet pipe system, however, the piping system contains air under pressure. When a sprinkler head fusible link melts, the air pressure is reduced, a “dry pipe” valve in the riser is opened by water pressure and water flows to any opened sprinkler heads. A small air compressor is required for this system.

b. Deluge sprinkler system A deluge type of fire suppression system consists of open-type sprinkler heads attached to a network of dry (not water-filled) piping which is automatically controlled by a fully supervised fire detection system which also serves as a fire alarm system. When a fire is detected, an automatic deluge valve is tripped open, admitting water to the system for discharge through all sprinkler heads.

c. Pre-action sprinkler system. The pre-action type of sprinkler system is similar to the above water spray deluge system except that it contains fusible link sprinkler heads. When the supervisory system opens the valve, water will flow through those sprinklers whose fixed temperature elements and fuses have been opened by the heat from a fire.

d. Carbon dioxide (CO₂) fire suppression system. A CO₂ fire suppression system usually consists of a trailer mounted low pressure refrigerated liquid CO₂ storage tank with temperature sensing controls to permit the automatic injection of piped CO₂ into areas to be protected. The system usually includes warning alarms to alert personnel whenever CO₂ is being injected into an actuated area. CO₂ will displace all oxygen in the area and suffocation can occur.

e. Sprinkler system pipe. There are several different types of pipe, valves and couplings from schedule 40 to light gage schedule 10 galvanized that are permissible for use in sprinkler systems. All must be NFPA approved.

f. Post indicator valves (PIVs) . PIVs are located in the supply line between the city water supply and the sprinkler system riser. The post is located above ground, includes a handle to operate the valve, includes an indicator of the open or shut valve position and includes a padlock for controlled access to operation of the valve.

g. Hose stations. Hose stations in wet pipe sprinkler systems are provided inside of buildings. They include a valve, festooned hose and nozzle and are housed in a cabinet with a glass door.

h. Ionization smoke detectors. Ionization smoke detectors contain a small amount of radioactive material which ionizes air in the sensing chamber, rendering it conductive and permitting a current flow. When smoke particles enter the ionization area the detector circuit responds with an alarm.

i. Photoelectric smoke detectors. Photoelectric spot type detectors contain a chamber that has either overlapping or porous covers of light that allow the entry of smoke. The unit contains a light source and a special photosensitive cell in the darkened chamber. As light is blocked with the admission of smoke particles, light striking the particles is scattered and reflected into the photosensitive cell and a circuit response is initiated.

j. Spot heat detectors. Spot type heat detectors sense heat. Above a predetermined level the detector trips and signals an alarm.

k. Portable fire extinguishers. Portable hand-held fire extinguishers should be provided and located throughout the facility in accordance with the NFPA. Fires that involve typical burning materials such as paper or trash should be treated with a Class A fire extinguisher. Class B extinguishers are used in fires that involve fuels and combustible fluids. Class C should be used in electrical fires. Class D, although rare, should be used on

specialized combustible metal such as magnesium. These extinguishers include a variety of fire suppression agents including water fog, CO₂, foams and dry chemicals which are matched to the classes of extinguishers available.

7-4. Pre-functional test plan and functional performance test plan for wet pipe sprinkler systems and fire detection systems

It should be assumed that individual components and packaged equipment have been tested by the manufacturer. As part of the commissioning effort each component should be checked for damage, deterioration and failures by a procedure using inspections and tests as defined by the specific equipment manufacturers and applicable NFPA standards. Equipment manuals from manufacturers identify the minimum required receipt inspections, handling and installation procedures, drawing and wiring verification, field inspection and installation checks, verification of removal of shipping braces, inspection of installation against drawings and nameplates, inspection of components for damage and cleanliness, inspection of insulators and grounding, inspection of anchorage and alignment, adjustment checks, mechanical operation and interlock checks, lubrication application and verification that local safety equipment is in place.

a. Fire suppression, detection, inspection, maintenance and testing. Tests, as required by the NFPA, fire department, insuring agency and authority having jurisdiction are done by licensed and bonded fire sprinkler companies and fire detection companies. Test reports are provided to the facility manager and others as requested. These tests should form the basis of commissioning as required by the commissioning plan. Some pre-functional tests may be conducted to provide general knowledge of the system. These are outlined in figure 7-2, wet pipe sprinkler system and fire detection system inspection checklist.

b. Fire codes. It is imperative that the NFPA Fire Code standards and manufacturer's recommendations relative to each suppression, detection and alarm system be consulted before any operation is performed on any of these systems.

c. Safety, fire suppression systems. Many tests involve the use of high voltages, high currents and pressurized water. These can be dangerous to personnel and damaging to equipment. A procedure should be followed to insure adequate safety rules are instituted and practiced to prevent injury to personnel performing the tests and other personnel who might be in the local area.

d. Test equipment, fire suppression systems. It is important that in any test program the proper equipment is used. The equipment should be calibrated, in good condition and used by qualified operators as required by a procedure. Any test equipment used for calibration shall have twice the accuracy of the system to be tested. All equipment should be operated in accordance with its instruction manual. A procedure defining installation inspection and a system test needs to be provided.

WET PIPE SPRINKLER SYSTEM AND FIRE DETECTION SYSTEM INSPECTION CHECKLIST						
SECTION A - CUSTOMER DATA						
1. PLANT East Building		2. LOCATION Washington, DC		3. JOB NUMBER EB03-103		
4. EQUIPMENT Fire Protection		5. SYSTEM DESIGNATION FP 1022		6. DATE (YYYYMMDD) 20030119		
7. TEST EQUIPMENT Pressure gauge, Alarm system manual, Fire system schematic				8. TESTED BY Roger Swanson		
SECTION B - EQUIPMENT DATA						
9. FIRE DETECTION CONTROL PANEL AND SYSTEM MANUFACTURER ADT Focus		10. MODEL NO ADT 23		11. SERIAL NO BD 23E465		12. LOCATION Front entrance
13. FIRE RISER				14. LOCATION Northeast corner		
SECTION C - VISUAL AND MECHANICAL INSPECTION						
15.	CHECKPOINT	COND*	NOTES	CHECKPOINT	COND*	NOTES
	EXTERIOR OF EQUIPMENT	A		EQUIPMENT IDENTIFICATION	A	
	COMPLETENESS OF ASSEMBLY	A		FREEZE PROTECT, VENTS AND DRAINS	A	
	CONTROL SYSTEM DISPLAY	A		LABELING AND TAGGING	A	
	ELECTRICAL MECHANICAL INTERLOCKS	A		WALLS AND OBJECTS NEAR SPRINKLER HEADS	A	
	SAFETY INTERLOCKS	A		MATERIALS BEING STORED	A	
	INSTRUMENTS AND ALARMS	A		OCCUPANCY	A	
	PROPER GROUNDING	R	C	PADLOCKS	A	
	PROPER INSULATION	A		ACCESS NEAR RISER PANEL AND FDC	A	
	LOCATION OF SPRINKLER HEADS	R	1	ANCHORAGE AND PIPE HANGERS	A	
	CONDITION OF SPRINKLER HEADS	R	2	COMPARISON TO DRAWINGS	R	3
SECTION D - CALIBRATION AND SET POINT						
16.		DESCRIPTION				NOTES
	GAUGES	Check to assure they are within pressure specifications				
	BATTERY AND CHARGER	Check for charge condition, corrosion, and battery specific gravity				
SECTION E - SYSTEM TESTS						
17.		OPERATING MODES	TEMPERATURES	PRESSURES	FLOWS	LEVELS
	HYDROSTATIC TEST	Standby	NA	45 - 95	NA	NA
	ALARM STRIKES	Alert	NA	NA	NA	4
	FLOW AND TAMPER SWITCHES	System test	NA	45 - 95	Rated	NA
	PULL STATIONS	Alert	NA	NA	by	NA
	FLOW TEST	System test	Rated	45 - 95	size	NA
	SYSTEM TEST	Alert	Rated	45 - 95	"	NA
18.	NOTES					
	1. Need additional heads over new equipment along West wall. 2. Need taller ladder for closer inspection. 3. Update drawings to include new sprinklers along West wall. 4. Verify all points. Operate properly. 5. Verify all stations operate and are accessible. 6. Test system during cold and hot ambient conditions.					
*CONDITION: A= ACCEPTABLE; R= NEEDS REPAIR/REPLACEMENT; C= ADJUSTMENT; C= CORRECTED; NA= NOT APPLICABLE						

Figure 7-2 Wet Pipe Sprinkle System and Fire Detection System Inspection Checklist

7-5. Possible failures and corrective measures for wet pipe sprinkler systems and fire detection systems

Table 7-1 lists general problems that may arise during the testing of equipment and systems along with possible troubleshooting techniques. For all problems, consult equipment and component manuals for troubleshooting directions. Check fuses/lights/breakers/etc., for continuity, check equipment calibration and settings, check for clogged strainers, check for closed manual shutoff valves, check for improperly adjusted valves and equipment and look for faulty equipment and connections.

a. Repair of wet pipe sprinkler system and fire detection system. It is recommended that adjustments and corrections to wet pipe sprinkler and fire detection systems be done by licensed and bonded fire sprinkler companies and fire detection companies.

b. Fire code compliance. It is imperative that the NFPA Fire Code standards and manufacturer's recommendations relative to each suppression, detection and alarm system be consulted before any operation is performed on any of these systems.

Table 7-1 Possible Failures and Corrective Actions for a Wet Pipe Sprinkler and Fire Protection System

	Areas to Check
Fire detection system	
Devices will not close/trip	Check mechanical alignment of tamper switches Check flow switches Check interlocks and safeties Check for mis-wired circuits Check control panel program Check power supply Check battery back-up power supply Check grounds
Devices trip inadvertently	Check protective device settings and operation Check for mis-wired circuits Check control panel program Check for system overload or short Check grounds Check local environmental conditions
Wet pipe sprinkler system	
Does not flow, flows at a reduced rate	Check shut off valves Check strainers and check valves Check city water supply Check pressures Check safeties and interlocks to fire protection systems Check for open drain valves
Water motor driven alarm does not sound	Check retard chamber Check for closed shut off valves Check strainers and drain Check for clogged water motor

**CHAPTER 8
LIFTING AND MOVING DEVICES (CRANES AND ELEVATORS)**

8-1. Description of lifting and moving devices

There are many types, variations and capacities of lifting and moving devices to move objects and personnel. The devices addressed in this course are primarily for moving objects; however freight elevators as well as personnel elevators can be used for moving personnel and objects. Included in this manual is a description of lifting and moving devices commonly encountered.

a. Lifting devices. A description of typical cranes and other common lifting devices follows.

- (1) Bridge cranes are versatile and used in many applications. They consist of columns, rails, a bridge, trolley, one or more hoists, and for control, a pendant, cab and radio operator.
- (2) Jib cranes have a limited access area but are less expensive than other cranes. They consist of a column, swinging jib, trolley, hoist and pendant.
- (3) Gantry cranes are like mobile bridge cranes. They consist of a mobile gantry, trolley, hoist and pendant.
- (4) Frequently used non-powered lifting devices include hydraulic jacks, chain hoists, and rigging such as chains, wire ropes, slings, chokers, hooks and spreader bars.

b. Elevators. Elevators consist of hydraulic ram lifts or motor driven cable lifts, a framed elevator shaft, an elevator car/enclosure with doors, telephone or intercom and push button controls.

c. Lifting and moving devices. More information on requirements for design, maintenance, and testing of lifting and moving devices is to be found in the Occupational Health and Safety Administration, Standards (OSHA), Regulations Standards 29 CFR 1910 – Subpart N Material Handling and Storage, 1910.179 Overhead and gantry cranes, and 1910.184 Slings, plus 1926 – Subpart H Material Handling, Storage, Use, and Disposal, 1926.251 Rigging equipment for material handling, as well as 1926 – Subpart N Cranes and Derricks, 1926.550 Cranes, derricks, hoists, elevators, and conveyers, and 1926.552 Material hoists, personnel hoists, and elevators, and 1926.554 Overhead hoists. Additional information is supplied by the American Society of Mechanical Engineers (ASME) A 17.1 Safety Code for Elevators and Escalators.

8-2. Operation of lifting and moving devices

Operation of the devices addressed in this course for moving objects and personnel follow.

a. Lifting devices, operation. Following is a discussion of the operation of cranes and other common lifting devices typically encountered in facilities.

- (1) Bridge cranes travel on rails supported by columns. End stops are provided on the rails to limit crane travel. The crane columns may be separate or integral with the building steel. Foundations must be designed for the additional load of the crane. The crane consists of the bridge which spans the distance between the rails, a trolley which traverses the bridge and one or more hoists located on the trolley. End stops are provided on the bridge to limit travel of the trolley and limit switches are provided on the hoist to limit travel of a wire rope-mounted hook. Travel is normally controlled by a pendant with separate buttons for movement in the north, south, east, and west directions for the bridge and trolley and up and down for the hook on the hoist. Motor speeds can be in steps or variably adjustable. Automatic brakes are provided on all traversing and lifting motors. In some cases the pendant is replaced with a radio controller, thereby eliminating the wire to the pendant. On larger

cranes, controls can be provided in a bridge mounted operator cab. The lifting capacity of the crane must be clearly indicated and visible to the operator. Operators and personnel must not be under the lifted load at any time.

- (2) A jib crane includes a counter weight foundation mounted column with a swinging jib. Stops are provided on the column to limit the swing of the jib and also on the jib to limit trolley movement. The hoist is pendant controlled and with limit switches to safely limit hook travel. The trolley and jib can also be powered if desired. The lifting capacity of the crane must be clearly indicated and visible to the operator. Operators and personnel must not be under the lifted load at any time.
- (3) Gantry cranes consist of an inverted “U” shaped structure called a gantry. The structure is mobile and can straddle objects. A trolley traverses the upper cross member and supports a hoist. The gantry and trolley can be powered similar to a bridge crane. Stops and limit switches are provided as needed to limit movement of the gantry, trolley, and hoist hook. A pendant is used for control. The lifting capacity of the crane must be clearly indicated and visible to the operator. Operators and personnel must not be under the lifted load at any time.
- (4) Non-powered lifting devices and rigging include hydraulic jacks, chain hoists, chains, wire ropes, slings, chokers, hooks, shackles and spreader bars. The lifting capacity of lifting devices and rigging must be clearly labeled. Operators and personnel must not be under any lifted load at any time and must not ride on any hook or load.

b. Elevators, operation. Elevators are used to lift freight and personnel. Lifting is accomplished by a hydraulic ram or cable drive with interlocks to control the acceleration, speed, stop positions, elevator doors, access doors and safety of the car. The elevator car/enclosure travels vertically in an elevator shaft with guide rails, and is provided with doors or a gate, roof hatch and push button controls. The doors/gate must be closed for the car to move. A mechanical safety brake is provided as a redundant safety to limit the travel of the car should all other mechanical and electrical interlocks and safeties experience a problem simultaneously. The lifting capacity of the elevator must be clearly indicated and visible to an operator. The car should be well lit, and be provided with an alarm, emergency lights and an emergency phone or intercom. Elevator entrances should be clear of tripping and slipping hazards. Elevators are the only lifting and moving devices which may be used to lift personnel.

8-3. Pre-functional test plan and functional performance test plan for lifting and moving devices

This manual assumes that individual components and packaged equipment have been tested by the manufacturer. As part of the commissioning effort each component should be checked for damage, deterioration and failures by a procedure using inspections and tests as defined by the specific equipment manufacturers. Equipment manuals from manufacturers identify the minimum required receipt inspections, handling and installation procedures, drawing and wiring verification, field inspection and installation checks, verification of removal of shipping braces, inspection of installation against drawings and nameplates, inspection of components for damage and cleanliness, inspection of insulators and grounding, inspection of anchorage and alignment, adjustment checks, mechanical operation and interlock checks, lubrication application and verification that local safety equipment is in place.

a. Tests, lifting and moving devices. Tests and inspections as defined by the American Society of Mechanical Engineers (ASME) and as recommended by OSHA and the insuring agency should be done by licensed and bonded crane/elevator companies. Inspection checklists are provided to the facility manager and others as requested. These tests should form the basis of acceptance as required by the commissioning plan. Some pre-functional tests may be conducted to provide general knowledge of the system. These are outlined in figure 8-1, lifting and moving devices inspection checklist and figure 8-2, elevator inspection checklist. These are filled

out to serve as an example of typical equipment conditions. For convenience, these checklists are included unpopulated at the end of the course material.

b. Safety, lifting and moving devices. Many tests involve the use of high voltages, high currents, pressurized hydraulic systems and heavy loads. These can be dangerous to personnel and damaging to equipment. A procedure should be followed to insure adequate safety rules are instituted and practiced to prevent injury to personnel performing the tests and other personnel who might be in the local area. Personnel are permitted to ride in personnel elevators and freight elevators appropriately equipped and labeled. Personnel must not ride on any lifting hook

c. Test equipment, lifting and moving devices. It is important that in any test program the proper equipment is used. The equipment should be calibrated, in good condition and used by qualified operators as required by a procedure. Any test equipment used for calibration shall have twice the accuracy of the equipment to be tested. All equipment should be operated in accordance with its instruction manual. A procedure defining installation inspection and moving and lifting equipment tests needs to be provided.

LIFTING AND MOVING DEVICES INSPECTION CHECKLIST						
SECTION A - CUSTOMER DATA						
1. PLANT East Building		2. LOCATION Washington, DC		3. JOB NUMBER EB03-104		
4. EQUIPMENT Forklift		5. SYSTEM DESIGNATION FL 02		6. DATE (YYYYMMDD) 20030120		
7. TEST EQUIPMENT Weight standard, Cable inspection gear, lift history				8. TESTED BY Roger Swanson		
SECTION B - EQUIPMENT DATA						
9. CRANE MANUFACTURER Grove Telescopic Boom		10. MODEL NO Y 2933	11. SERIAL NO 81704	12. LOCATION Building 42	13. CAPACITY 22 Tons	
14. HOIST MANUFACTURER M Y -TE		15. MODEL NO 10-22	16. SERIAL NO 2375	17. LOCATION Building 42	18. CAPACITY 750 lbs	
SECTION C - VISUAL AND MECHANICAL INSPECTION						
19.	CHECKPOINT	COND*	NOTES	CHECKPOINT	COND*	NOTES
	EXTERIOR OF EQUIPMENT	A		EQUIPMENT IDENTIFICATION	A	
	COMPLETENESS OF ASSEMBLY	A		EQUIPMENT CONDITION	A	
	CONTROL SYSTEM DISPLAY	A		CAPACITY IDENTIFICATION	A	
	SAFETY INTERLOCKS	A		LABELING AND TAGGING	A	
	ELECTRICAL/MECHANICAL INTERLOCKS	A		END AND/OR SWING STOPS IN PLACE	A	
	INSTRUMENTS AND ALARMS	R	I	ACCESS	A	
	PROPER GROUNDING	A		ANCHORAGE	A	
	PROPER INSULATION	A		COMPARISON TO DRAWINGS	NA	
	CABLE CHAIN CONDITION	A		ALIGNMENT	NA	
SECTION D - CALIBRATION AND SET POINT						
20.	DESCRIPTION				NOTES	
	LIMIT SWITCHES	Check for proper adjustment and operation				
SECTION E - LIFTING AND MOVING DEVICES EQUIPMENT TESTS						
21.	PASS	FAIL	COMMENTS		NOTES	
	LOAD TEST	X				
	TEST ALL BRAKES	X				
	SAFETY TEST	X				
	ALARMS	X				
	CABLE HOOK INSPECTION	X				
	OPERATIONAL TEST	X				
22. NOTES						
1. Glass cracked on hydraulic pressure gauge.						
*CONDITION: A= ACCEPTABLE; R= NEEDS REPAIR, REPLACEMENT OR ADJUSTMENT; C= CORRECTED; NA= NOT APPLICABLE						

Figure 8-1 Lifting and Moving Devices Inspection Checklist

ELEVATOR INSPECTION CHECKLIST						
SECTION A - CUSTOMER DATA						
1. PLANT East Building		2. LOCATION Washington, DC		3. JOB NUMBER EB03-105		
4. EQUIPMENT		5. SYSTEM DESIGNATION Otis 23		6. DATE (YYYYMMDD) 20030121		
7. TEST EQUIPMENT Voltmeter, Pressure tester, Hand tools for visual as required by type elevator				8. TESTED BY David Ryan		
SECTION B - EQUIPMENT DATA						
9. ELEVATOR MANUFACTURER Otis		10. MODEL NO Hydraulic	11. SERIAL NO 1290	12. LOCATION Front entrance	13. CAPACITY 2000 lbs	
14. DRIVE MANUFACTURER Otis		15. MODEL NO Otis	16. SERIAL NO 3241656	17. LOCATION Rooftop	18. CAPACITY 4000 lbs	
SECTION C - VISUAL AND MECHANICAL INSPECTION						
19.	CHECKPOINT	COND*	NOTES	CHECKPOINT	COND*	NOTES
	EXTERIOR OF EQUIPMENT	A		EQUIPMENT IDENTIFICATION	A	
	COMPLETENESS OF ASSEMBLY	A		EQUIPMENT CONDITION	A	
	CONTROL SYSTEM DISPLAY	A		CAPACITY IDENTIFICATION	A	
	SAFETY INTERLOCKS	A		LABELLING AND TAGGING	A	
	ELECTRICAL/MECHANICAL INTERLOCKS	A		ALARM, TELEPHONE, INTERCOM	A	
	INSTRUMENTS AND ALARMS	A		ACCESS	A	
	PROPER GROUNDING	A		ANCHORAGE	A	
	PROPER INSULATION	A		COMPARISON TO DRAWINGS	A	
	ELEVATOR DOORS	A	I	ALIGNMENT	A	
	ENTRANCEWAY	A		HYDRAULIC LEAKS	A	
	CABLE CHAIN CONDITION	A				
SECTION D - CALIBRATION AND SET POINT						
20.	DESCRIPTION				NOTES	
	HYDRAULIC PRESSURE	Note pressure measurements and extreme positions of operation				
	DOOR POSITION	Note ease of operation and opened and closed positions of doors				
SECTION E - LIFTING AND MOVING DEVICES EQUIPMENT TESTS						
21.	PASS	FAIL	COMMENTS		NOTES	
	LOAD TEST	X		Load elevator to indicated rated load		
	TEST ALL BRAKES	X		Emergency stop		
	SAFETIES TEST	X				
	ALARMS	X				
	OPERATIONAL TEST	X				
22. NOTES 1. Doors worked smoothly						
*CONDITION: A= ACCEPTABLE; R= NEEDS REPAIR, REPLACEMENT OR ADJUSTMENT; C= CORRECTED; NA= NOT APPLICABLE						

Figure 8-2 Elevator Inspection Checklist

8-4. Possible failures and corrective measures for lifting and moving devices

Table 8-1 lists general problems that may arise during the testing of equipment and systems along with possible troubleshooting techniques. For all problems, consult equipment and component manuals for troubleshooting directions. Check fuses/lights/breakers/etc., for continuity, check equipment calibration and settings, check for improperly adjusted equipment and limit/proximity switches and look for faulty equipment and connections.

Table 8-1 Possible Failures and Corrective Actions For Lifting and Moving Devices

	Areas to Check
Bridge cranes, jib cranes, gantry cranes	
Hoist, trolley, bridge, gantry will not actuate/move	Check key lockout switch Check control buttons/levers/joy-stick actuation and contacts Check radio signal if applicable Check mechanical alignment of limit/proximity switches Check interlocks and safeties Check for mis-wired circuits Check control panel program Check power supply Check grounds
	Check protective device settings and operation Check for mis-wired circuits Check control panel program Check for system overload or short Check grounds
Elevator	
Does not move	Check door/gate interlocks Check control buttons actuation and contacts Check mechanical alignment of limit/proximity switches Check interlocks and safeties Check for miss-wired circuits Check control panel program Check power supply Check grounds
Doors do not open	Check car stop position and limit/proximity switches Check car door / access door interlock Check safeties and interlocks
Car stops above or below floor level	Check car stop position and limit/proximity switches

CHAPTER 9 WATER AND SEWAGE TREATMENT SYSTEMS

9-1. Description of water and sewage treatment systems

A description of a typical potable water supply, process water supply and small and large scale sewage treatment systems follows. Additional information on water and sewage treatment equipment and systems is presented in paragraph 9-3, General water and sewage treatment equipment description and operation.

a. Facility potable water and process water supply. The water supply to a facility normally meets potable (drinking) water standards. The water supply is separated from facility potable water with a back flow preventer and from the facility process water with a second back flow preventer.

- (1) A typical water system is shown in figure 9-1, Schematic of a typical potable and process water system. The system consists of the water supply, isolation valves, strainer, back flow preventers, drain, pressure regulators and gages.

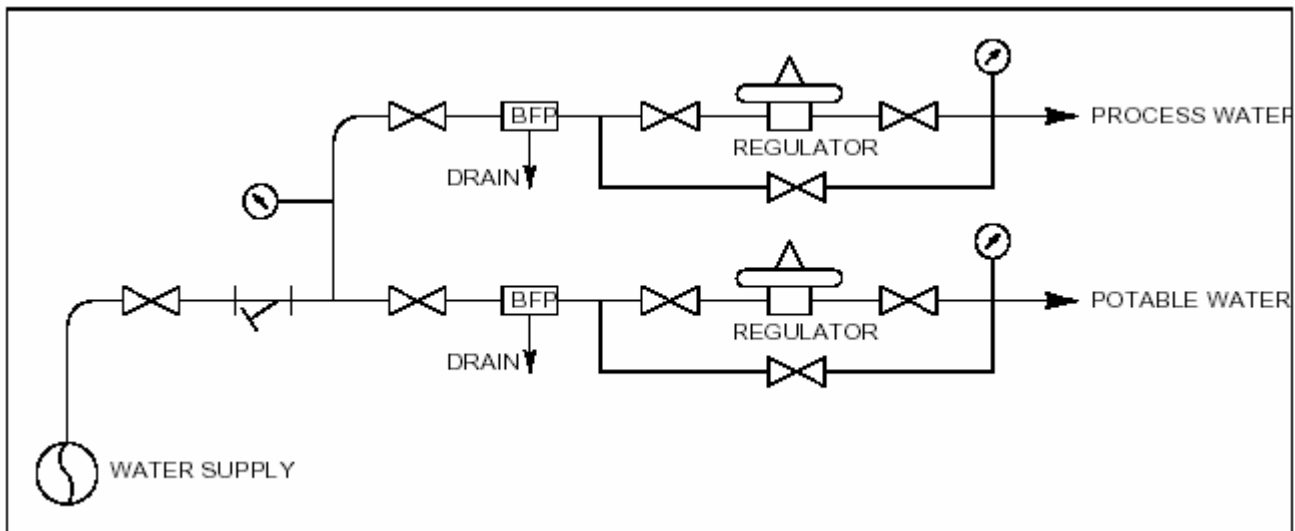

Figure 9-1 Schematic of a Typical Potable and Process Water System

- (2) Water treatment is needed for process water used in chilled water, heating water and steam and cooling tower systems. The type of treatment depends on the quality of the water supply and the types of equipment in service. The typical systems presented elsewhere in the course material include a chilled water system and a heating water system. Process water is used for fill and makeup water on both of these systems.

(3) Process water for closed loop chilled and heating water systems needs to be treated to control corrosion, scale formation, growth of biological agents and pH. In the closed cooling water system, treatment of the water for dissolved oxygen (O₂) to prevent corrosion is needed during filling or when opened for maintenance. Scale is usually not a problem in chilled water systems. In the closed heating water system, monitoring is needed for corrosion from dissolved O₂ and scale formation from precipitation of minerals in the water. A typical process water treatment system is presented in figure 9-2, Process water treatment schematic. Process water treatment consists of a pot feeder, feeder fill point, isolation valves and chemicals.

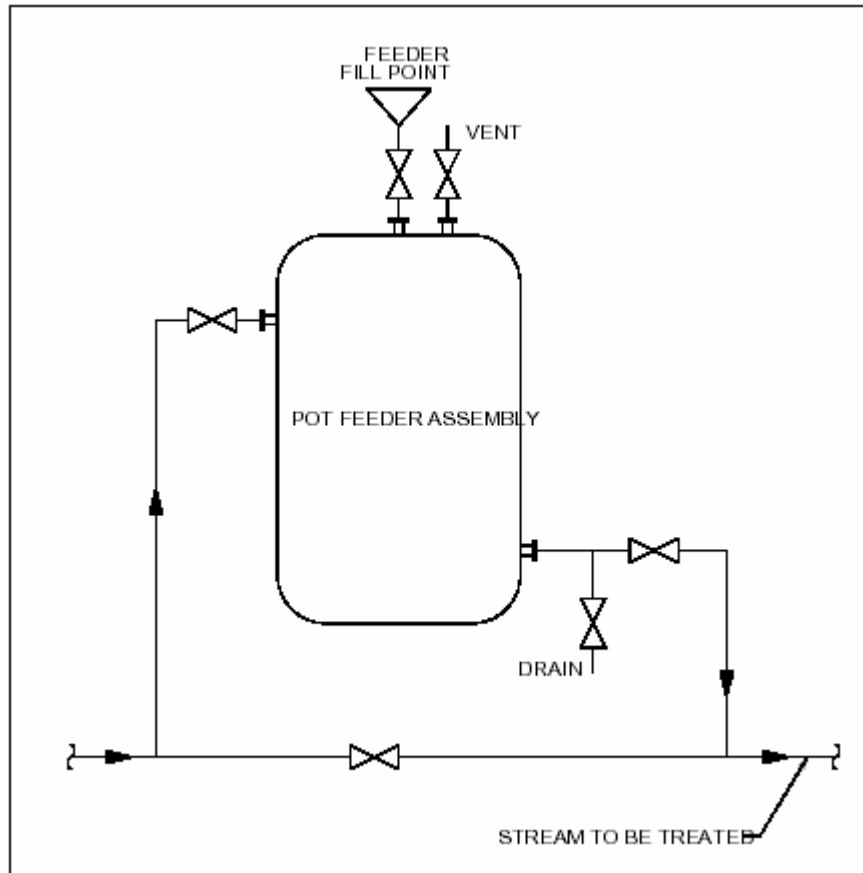

Figure 9-2 Schematic of a Process Water Treatment System

b. Sewage treatment systems. Sanitary sewage is any liquid waste containing animal matter, vegetable matter and/or certain chemicals in suspension or solution. It excludes storm, surface and ground water. Sewage treatment removes impurities so that the remaining water can be safely returned to the natural water cycle.

- (1) Sewage treatment for small facilities in remote or rural areas involves a septic tank and drain field. Refer to figure 9-3 for a cross section of a septic tank.
- (2) Sewage treatment for larger facilities and facility complexes can consist of source, preliminary, primary, secondary and advanced treatment operations.
- (3) Treatment at the source of wastewater to render it safe for sanitary sewage treatment can vary greatly depending on the chemical, manufacturing, or operational processes which produce the waste water. In the sewage treatment facility, preliminary treatment is provided to protect downstream equipment and minimize operational problems. Preliminary treatment includes neutralization, screening, grit removal and temperature adjustment. Primary treatment at times requires chemical addition but mainly involves physical treatment of the waste to remove settleable and floatable materials. In primary treatment, settling tanks are used for solids removal.
- (4) Secondary wastewater treatment relies on naturally occurring microorganisms acting to break down organic material and purify the liquid. Secondary treatment brings air and therefore O₂ in contact with sewage to encourage micro-organisms to grow, thereby removing substantial quantities of dissolved organics and colloidal materials. This results in purified water. The process or combination

of processes used in advanced sewage treatment systems are dictated by effluent quality standards which exceed established secondary treatment standards.

- (5) The typical sanitary sewage waste treatment system selected for discussion in this manual is the trickling filter process shown in figure 10-4, Sewage trickling filter process. The system consists of a preliminary treatment system, primary sedimentation tank, high rate trickling filter, secondary sedimentation tank, disinfection unit, sludge thickener, sludge dewatering tank and sludge digestion unit.

c. Water and sewage treatment systems. More information on design, maintenance and testing of water and sewage treatment systems is found in the Management of Industrial Pollutants by Anaerobic Processes by Alan W. Obayashi and Joseph M. Gorgan, Rensselaer Polytechnic Institute, May 1984.

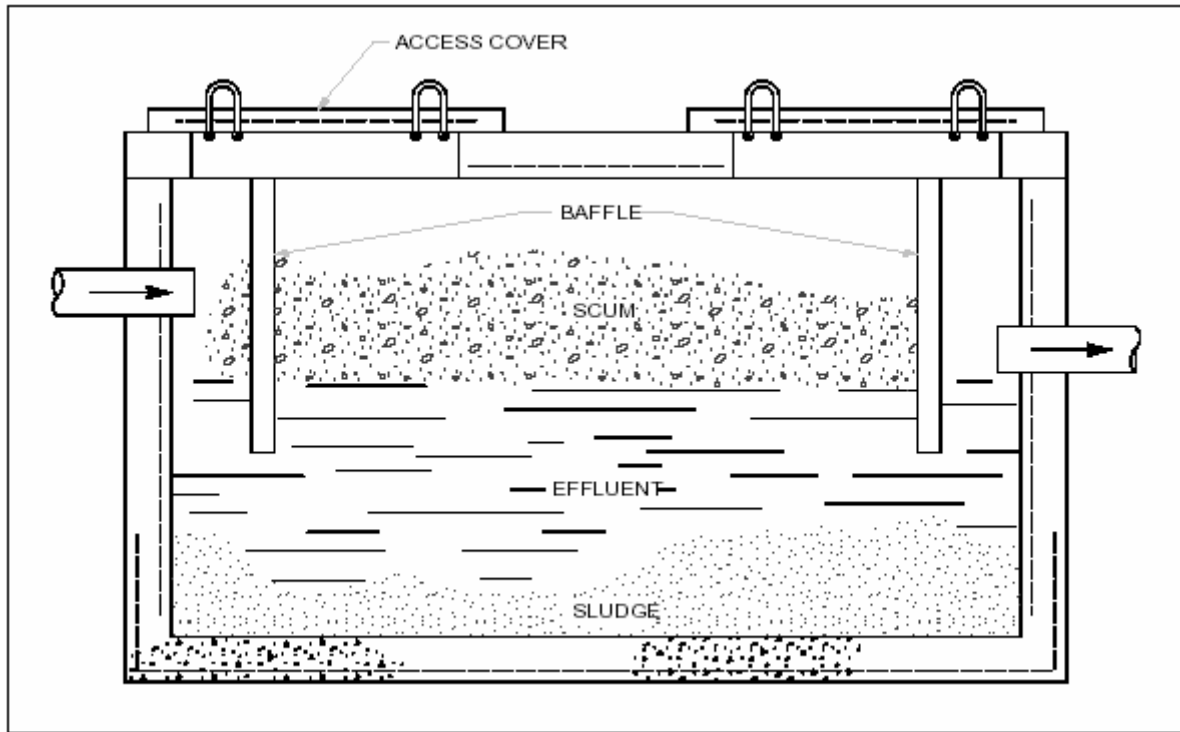

Figure 9-3 Cross Section of a Septic Tank

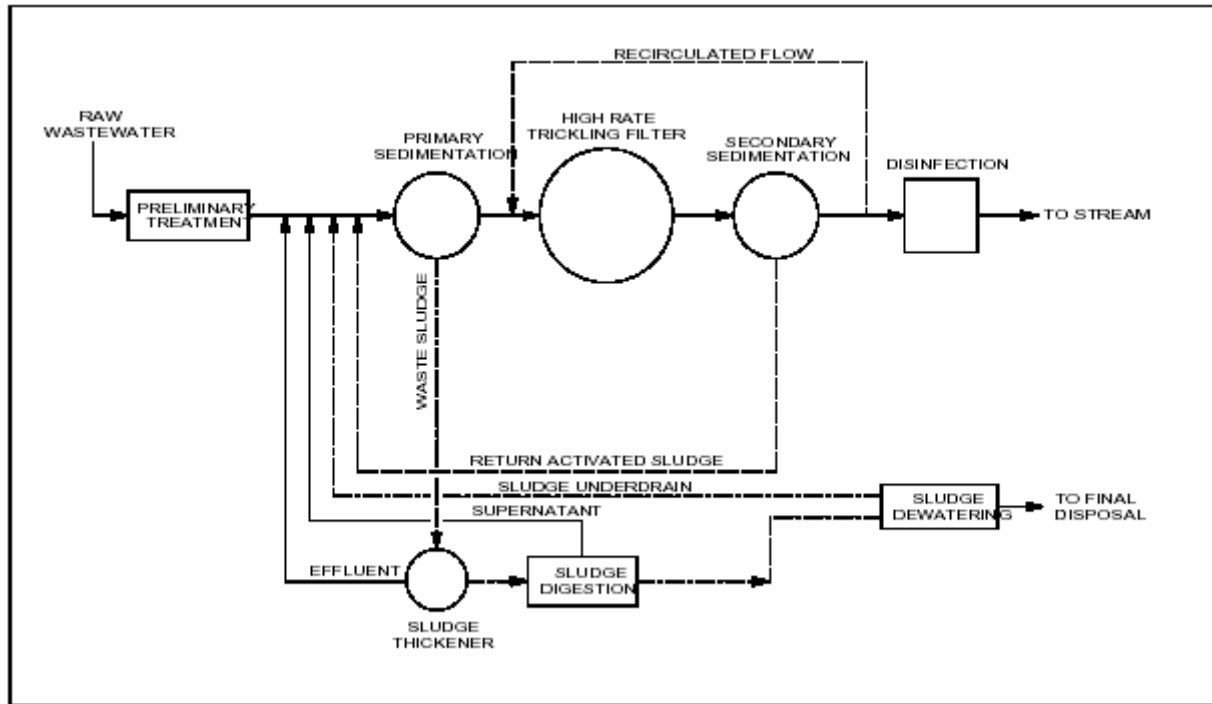

Figure 9-4 Sewage trickling Filter Process

9-2. Operation of water and sewage treatment systems

A discussion on the operation of the typical potable water supply, process water supply and small and large scale sewage treatment systems follows.

a. Potable water system, operation. For both the facility potable water and process water, the water supply to the facility flows through a shutoff valve, strainer, isolation valves, back flow preventer and pressure regulator. The strainer removes particles from the water and can be back flushed for cleaning. Valves are located up and down stream of the pressure regulator and a bypass installed as needed for change out of the regulator. The back flow preventer incorporates a drain to bleed off water which back flows as a result of back pressure and a malfunction with one of the check valves contained within the unit. This protects the water supply from contamination by preventing facility potable and process water from flowing backward into the water supply.

b. Process water treatment system, operation. An analysis of the water supply and process water in the chilled and heating water systems determines the type of treatment and chemicals needed.

- (1) To treat process water, chemicals are fed into a pot feeder and introduced into the process water system by manipulation of isolation valves which allow process water to flow through the pot, mix with the chemicals and flow back into the system.
- (2) Manufactured chemical products contain combinations of proprietary chemicals and different forms of generic chemicals to enhance water treatment performance. Water treatment chemical suppliers tailor chemical treatment needs to local water conditions and establish procedures for safe chemical storage and handling. Some basic chemicals include: sodium hydroxide (NaOH) which increases alkalinity, chelants (EDTA, NTA) which control scaling and sodium sulfate (Na_2SO_3) and Hydrazine (N_2H_2) which prevent O_2 corrosion.

c. Small scale sewage treatment system, operation. In a septic system, sewage from a small facility flows into an underground septic tank. Solids settle out as sludge on the bottom of the tank and are anaerobically digested. Gases produced by digestion are vented back through the plumbing of the facilities through vent stacks in the roof. A scum forms on the top and an almost clear effluent develops in the middle as solids settle and separate. An inlet baffle aids the separation of suspended solids and provides minimal agitation of the sludge for anaerobic digestion. An outlet baffle prevents scum from entering the outlet pipe and clogging the drain field tile. The outlet pipe is connected to a drain field which consists of a perforated, usually plastic pipe or tile, which may run several hundred feet underground depending on the ability of the ground to percolate water. The sloped drain tile is embedded in layers of sand and rock to facilitate percolation and is located below the frost line. Construction of septic systems is monitored by local authorities to insure proper construction and therefore proper operation of these passive sewage treatment systems.

d. Large scale sewage treatment system, operation. In the larger capacity typical sanitary sewage trickling filter process, the preliminary treatment system utilizes bar screens to remove wood, plastic, rags, paper and other large solid objects from sewage influent. Sand and grit which can damage pumps are also removed. A primary sedimentation tank is next in the process. It allows sufficient settling time to permit approximately 50 to 70 percent of the remaining solids to settle out and removes 30 to 40 percent of the biochemical O₂ demand (BOD).

- (1) Next a high rate trickling or percolating filter provides an environment encouraging aerobic microorganisms to feed on bacteria in the sewage. Sewage is pumped through spray bars and is trickled over stones in an open air tank. The trickling and the drops falling from one stone to the next provide exposure of the liquid to air, and the rocks provide a surface for microorganisms to live on. These conditions promote aerobic microorganism growth and consumption of sewage bacteria thus removing the remaining BOD and suspended solids.
- (2) A secondary sedimentation tank provides residence time to separate biological sludge from the purified water exiting the trickling filter. To destroy pathogenic organisms, the water is disinfected with hypochlorate, ozone (O₃), or ultraviolet (UV) light and discharged to a stream or natural body of water. Periodic unannounced sampling by local authorities insures that the discharge remains within safe and legal limits.
- (3) Sludge from the secondary sedimentation tank consists of 90 percent organic matter and 2 to 4 percent solids and is pumped back to the primary sedimentation tank.
- (4) Sludge from the primary sedimentation tank is mostly water containing organic matter. It is pumped to a sludge thickener. In the thickener, sludge volume is reduced to half and effluent is recycled to the primary sedimentation tank. The sludge is then pumped to the digestion unit. In the digester, organic matter in the sludge is decomposed by anaerobic bacteria which further breaks down the sludge rendering it inert and eliminating health concerns. Anaerobic bacteria does not require free O₂ to decompose organic matter. It does allow separation of solids and water, reduces sludge volume, increases sludge density and produces combustible methane gas in combination with other gases.
- (5) Sludge produced in the digester consisting of relatively stable inert organic and inorganic compounds continues on to a sludge dewatering system and then disposal. It can also be sold as soil conditioner. The supernatant liquids (usually a clear liquid overlying material deposited by settling or precipitation) produced are returned to the primary sedimentation tank and the gases are cleaned and stored. The combustible gases can be used to generate heat for local processes or sold as combustible fuel.

- (6) Monitoring of sewage flow and effluent discharge is required by the Environmental Protection Agency (EPA) when National Pollution Discharge Elimination System (NPDES) compliance is required as part of the discharge permit.

9-3. General water and sewage treatment equipment description and operation

There are many ways to treat water to be used in industrial processes and for human consumption. In addition there are also many ways to treat sanitary sewage so that it can be safely returned to the natural water cycle. Following is a discussion of some of the equipment and systems available to treat water and sewage.

a. Water disinfection. Chlorination is the traditional disinfectant used in municipal water treatment. It is a strong oxidizing agent, inexpensive, reliable, easy to use and monitor and safe when handled properly. Chlorination with chlorine gas is the oldest method of continuous disinfection method used in public water supplies. It was initially introduced in 1904. Disinfection by chlorination has been studied extensively, and is the standard by which other disinfection procedures are judged. Disinfecting forms of chlorine are hypochlorites, chlorine dioxide and products of chlorine-ammonia reactions.

- (1) Simple diffuser systems are adequate for distributing chlorine into water, with warming of the supply tank required for high feeding rates. Hazards of working with chlorine include explosions of pressure vessels (especially if corrosion weakens them) and violent reactions when chlorine comes in contact with oxidizable substances.
- (2) Chlorination is the final step for most wastewater treatment plants. In addition to disinfection of the effluent, BOD is reduced because reaction with chlorine substitutes for reaction with O₂. The residual chlorine discourages iron bacteria that form slimes in effluent conduits and insects are also killed. Most smelly compounds in treatment plant effluents are easily reacted with chlorine, usually to odorless products. Unfortunately, the products of chlorination may be hazardous and some are known carcinogens. Concentrations in the environment may be much higher than in the effluents because microorganisms or other life forms ingest and store chlorinated organic compounds.
- (3) O₃ (ozone) is also used for disinfection. O₃ is a colorless gas at room temperature, and has a peculiar, pungent odor. O₃ is unstable and cannot be produced and transported. It is generated at its point of use by an electrical corona discharge or UV irradiation of dry air or O₂. O₃ can be injected or diffused into the water supply stream.
- (4) Advantages of O₃ over chlorine include the following.
 - (a) Safety problems of chlorine storage, handling, and transportation are eliminated. O₃ is produced on-site.
 - (b) O₃ destroys both bacteria and viruses, while chlorine is not very effective against viruses.
 - (c) O₃ has shorter treatment times (one to ten minutes for O₃ versus 30 to 45 minutes for chlorine).
 - (d) There are lesser pH and temperature effects with O₃.
 - (e) High dissolved O₂ concentration from ozonation improves receiving stream quality.
 - (f) No toxicity to aquatic life has been found in studies of O₃ disinfection.
 - (g) No buildup of bioaccumulatable residuals has been observed in O₃-treated effluents.
 - (h) There is no increase in total dissolved solids in O₃-treated water.
 - (i) Wastewater quality improvements such as turbidity reduction and effluent decolorization accompany O₃ treatment.
- (5) The disadvantages in using O₃ to treat water include the following.
 - (a) It is costly to produce O₃, for both capital equipment and operating power requirements.

(b) O₃ is toxic. The Public Health Department has set the maximum safe working concentration at 0.1 ppm.

(c) There is great difficulty in accurately determining the concentration of O₃ in water. The best method thus far has an error of ± 1 percent.

- (6) UV light is another method of disinfection. UV light used for disinfection occupies the spectral range from just below visible light to soft X-rays. UV radiation at about the center of the range has been found to kill or deactivate many pathogens. UV treatment does not necessarily kill the target organism, instead the radiation alters cell DNA so that the organism is sterilized. This serves to inactivate the pathogen so that it cannot proliferate and cause disease.
- (7) Bacteria are the easiest group to treat and differ the least in amount of radiation required. Viruses are most resistant and variable. Cysts and worms are unaffected by UV light so if present they must be treated by another procedure.
- (8) UV treatment adds nothing to the water and does not require the addition of treatment materials as long as the system used is maintained in good operating condition. Extensive contact time is not required in this process making it a time efficient treatment option.
- (9) The major disadvantage is that there is no residual for treatment beyond the device. If contaminants enter after treatment, another disinfection method such as chlorination must be used to sanitize the system and treat the water. Some pathogens deactivated by UV light may be reactivated when exposed to O₂. UV light is easily absorbed by solids, including particulate matter in the water or deposits on the lamp surface. As a consequence, UV light treatment should only be attempted on clear water. Water systems which store potable water for long periods may require disinfection to control the growth of biological contaminants and algae. Water samples taken are tested to determine the amount and strength of hypochlorite solution treatment needed. Disinfection can be accomplished by directly injecting hypochlorite into the water, adding hypochlorite into a recirculating side stream or a combination of both.

b. Process water treatment. Open process water systems in cooling towers are constantly exposed to air and with constant evaporation, raw water is continually being introduced. As a result the cooling water can contain large amounts of dissolved O₂ and the concentration of impurities/dissolved solids increases significantly over time. Frequent water quality monitoring is needed to control corrosion, scale formation, growth of biological agents and pH. The dissolved solids are usually removed with controlled periodic blowdown of the system. Treatment methods can be as simple as an operator adding slugs of chemicals to a pot/tank or can be as sophisticated as using a continuous analyzer to automatically control operation of chemical metering pumps. The pumps inject chemicals into the water stream to maintain uniform water quality. The analyzer reads output signals from instruments/probes in the process water stream to measure pH, conductivity, dissolved solids concentration, raw water flow and corrosion. The analyzer signals metering pumps to inject appropriate quantities of chemicals in the water to adjust quality. In less sophisticated systems where periodic sampling has indicated changes to water quality are slow and fairly constant, fixed doses of chemicals can be injected by metering pumps run on timers.

- (1) Steam boilers above 600 psig may have problems with water foaming and caustic embrittlement of metal components. For these boilers water quality is typically accomplished by a combination of chemical treatment, deaeration and blowdown.
- (2) Deaeration is the removal of dissolved gaseous carbon dioxide (CO₂) and O₂ from supply water. These gases greatly increase corrosivity and when heated in boiler systems combine with water to form carbonic acid. Removal of O₂, CO₂, and other non-condensable gases from boiler feedwater is vital to

boiler equipment longevity as well as safety of operation. Carbonic acid corrodes metal, reducing the life of equipment and piping. It also dissolves iron which when returned to the boiler precipitates and causes scaling on the boiler tubes contributing to reduced life and also increased energy consumption to achieve heat transfer.

- (3) Mechanical deaeration is typically utilized prior to the addition of chemical O₂ scavengers. In mechanical deaeration boiler feedwater is heated with steam. This scrubbing action releases O₂ and CO₂ gases which are then vented. Trace O₂ is removed with a chemical O₂ scavenger such as Na₂SO₃ or N₂O₂. Free CO₂ can be removed by deaeration, but this process only removes small amounts of combined CO₂. The majority of the combined CO₂ is removed in the steam, subsequently dissolving in the condensate and causing corrosion problems. These problems can be controlled through the use of volatile neutralizing amines or filming amines.
- (4) Water softeners are used to remove dissolved solids for reduced foaming and scale formation. Water softeners contain a plastic bead or zeolite in a column. The zeolite is saturated with sodium chloride, salt. When water is passed through the column, the calcium and magnesium in the water is replaced with sodium. The water is said to be soft at this point. The sodium compounds do not settle out and cause scale or other problems of the hard water. The column is regenerated with a strong salt/brine solution and backflushed.
- (5) Ion exchange units have a cation exchange column to remove metals and hardness and an anion exchange column to control alkalinity and reduce corrosion, embrittlement, hard scale and foaming. Each exchange column uses a treated resin bed to collect contaminants through a chemical exchange process. When the beds become saturated they are back washed, treated with an electrolyte, rinsed and placed back in service. Duplex columns are used to achieve continuous operation.

c. Water treatment piping. For water treatment systems common pipe, valve, and pump materials include cast and forged carbon and stainless steel. Low pressure systems can use plastic materials such as polyvinyl chloride (PVC).

d. Sewage treatment processes. Other methods for treating sanitary sewage are discussed in the following paragraphs.

- (1) The plug flow activated sludge process is another process used to treat sanitary sewage. This process meets secondary treatment effluent limits. The process includes a bar screen as preliminary treatment and a comminutor (a device which reduces material to minute particles, pulverizer), a grit chamber and oil and grease removal units. The primary aerated wastewater and acclimated microorganisms are aerated in a tank. Flocculent activated sludge solids are separated from the wastewater in a secondary clarifier. The clarified wastewater flows forward for further treatment or discharge. A portion of the clarifier sludge is returned to the aeration tank for mixing with the primary-treated influent to the basin and the remaining sludge is pumped to the sludge handling portion of the treatment plant.
- (2) Another sanitary treatment process is the stabilization or oxidation pond process. This process uses a relatively shallow body of wastewater in an earthen basin to treat a variety of wastewater and functions under a range of weather conditions. The ponds can be aerobic or layered with aerobic and anaerobic layers. They can be used in combination with other treatment processes. Their operational and maintenance requirements are minimal.
- (3) Advanced wastewater treatment achieves pollutant reductions by methods other than sedimentation, activated sludge and trickling filters used in conventional treatment. Advanced treatment employs a number of different unit operations, including ponds, post-aeration, micro-straining, various types of

filtration, carbon adsorption, membrane solids separation, land application, biomass growth, soil biota growth, nitrification/de-nitrification and other treatment processes. Phosphorus and nitrogen removal processes can consist of additional treatment ponds; post-aeration through advanced methods; and the addition of minerals, lime, metal salts and polymers for removal through flocculation (mass formed by the aggregation of a number of fine suspended particles) or precipitation.

e. Sewage treatment ancillary equipment. Following is a description of some of the types of ancillary equipment needed for the treatment of sewage.

- (1) Sewage flow measurement is needed to assure compliance with permits and to evaluate and adjust treatment processes. Flow can be measured with weirs, Parshall flumes and magnetic and ultrasonic flow meters.
- (2) Sewage sampling is needed to assure compliance with permits and to evaluate and adjust treatment processes. Proportional flow, composite and grab-sample collection sampling is done at several locations in the process for this purpose.
- (3) Monitoring equipment is used to indicate and/or record flow quantities and pressure, temperature, liquid levels, velocities, dissolved O₂, biochemical O₂ demand, total suspended solids, ammonia, nitrate and pH.
- (4) Sewage lift stations and sump pumps are needed where there is not enough elevation drop available for the sewage to flow by gravity all the way to the septic tank or treatment plant. Lift stations provide pits or sumps with submerged centrifugal motor driven pumps or compressed air driven ejector pumps.

9-4. Pre-functional test plan and functional performance test plan for water and sewage treatment systems

It is to be assumed that individual components and packaged equipment have been tested by the manufacturer. As part of the commissioning effort each component should be checked for damage, deterioration and failures by a procedure using inspections and tests as defined by the specific equipment manufacturers. Equipment manuals from manufacturers identify the minimum required receipt inspections, handling and installation procedures, drawing and wiring verification, field inspection and installation checks, verification of removal of shipping braces, inspection of installation against drawings and nameplates, inspection of components for damage and cleanliness, inspection of insulators and grounding, inspection of anchorage and alignment, adjustment checks, mechanical operation and interlock checks, lubrication application and verification that local safety equipment is in place.

a. Chemical selection verification. As part of the commissioning effort proper selection and dose quantity of chemicals for treatment of water and sewage need to be verified. A procedure must be followed to insure proper chemical treatment and water quality.

b. Safety, water and sewage treatment systems. Many tests on equipment involve the use of chemicals, combustible gases, high voltages, high currents, pressurized water and rotating or moving equipment. These conditions can be dangerous to personnel and damaging to equipment. A procedure must be followed to insure adequate safety rules are instituted and practiced to prevent explosion and/or injury to personnel performing the tests and other personnel who might be in the local area. Sanitary manholes contain harmful gases and are considered confined space. Confined space entry safety procedures must be followed and adequate ventilation provided before entering a manhole.

c. Test equipment, water and sewage treatment systems. It is important that in any test program the proper equipment is used. The equipment should be calibrated, in good condition and used by qualified operators as required by a procedure. Any test equipment used for calibration shall have twice the accuracy of the equipment to be tested. All equipment should be operated in accordance with its instruction manual. A procedure defining installation inspection and a system test needs to be provided.

d. Inspection checklists for water and sewage treatment systems. Inspection checklists for the typical water and sewage treatment systems are presented in figure 9-5, Water supply and treatment system inspection checklist and figure 9-6, Sewage treatment systems inspection checklist. These are filled out to serve examples of typical equipment conditions. For convenience, this checklist is included unpopulated at the end of the course material.

9-5. Possible failures and corrective measures for water and sewage treatment systems

Table 9-1 lists general problems that may arise during the testing of equipment and systems along with possible troubleshooting techniques. For all problems, consult equipment and component manuals for troubleshooting directions. Check fuses/lights/breakers/etc., for continuity, check equipment calibration and settings, check for clogged filters, strainers and lines, check for closed manual shut off valves, check for improperly adjusted valves and equipment and look for faulty equipment and connections.

WATER SUPPLY AND TREATMENT SYSTEM INSPECTION CHECKLIST					
SECTION A - CUSTOMER DATA					
1. PLANT Building 42	2. LOCATION Washington, DC	3. JOB NUMBER B42-105			
4. EQUIPMENT	5. SYSTEM DESIGNATION WPT 22	6. DATE (YYYYMMDD) 20030117			
7. TEST EQUIPMENT Water test kit 22, Pro-Master equipment				8. TESTED BY Charles Gray	
SECTION B - EQUIPMENT DATA					
9. BACKFLOW PREVENTER MANUFACTURER PVC	10. MODEL NO PV-4300	11. SERIAL NO 543622	12. FLOW RATING 4 inch pipe		
13. PRESSURE REGULATOR PVC	14. MODEL NO PV-8900	15. SERIAL NO 653466	16. FLOW RATING As required sizing		
17. CHEMICAL FEED POT MANUFACTURER PVC	18. MODEL NO PV-9200	19. SERIAL NO 987676	20. CAPACITY As req'd for system ops		
SECTION C - VISUAL AND MECHANICAL INSPECTION					
21.	CHECKPOINT	COND*	NOTES	CHECKPOINT	COND* NOTES
	EXTERIOR OF EQUIPMENT	A		IDENTIFICATION	A
	COMPLETENESS OF ASSEMBLY	A		BRACING/SUPPORTS	A
	INTERLOCKS	A		LABELING AND TAGGING	A
	INSTRUMENTS	A		WORKING SPACE	A
	PROPER GROUNDING	A		ANCHORAGE	A
	PROPER INSULATION	A		COMPARISON TO DRAWINGS	A
	TIGHTNESS OF BOLTED CONNECTIONS	A		WELD INSPECTION	A
	LEAKS	A			
SECTION D - CALIBRATION AND SETTING					
22.	DESCRIPTION				NOTES
	BACKFLOW PREVENTER	Perform required test procedure to confirm operation			
	PRESSURE REGULATOR	Perform required test procedure to confirm operation			
	GAGES	Check against standard			
	LIMIT SWITCHES AND LINKAGES	Check for operation, corrosion, etc.			
SECTION E - SYSTEM TESTS					
23.	PASS	FAIL	COMMENTS		NOTES
	X				
	X				
	X				
	X				
24. NOTES					
* CONDITION: A= ACCEPTABLE; R= NEEDS REPAIR, REPLACEMENT OR ADJUSTMENT; C= CORRECTED; NA= NOT APPLICABLE					

Figure 9-5 Water Supply and Treatment System Inspection Checklist

SEWAGE TREATMENT SYSTEM INSPECTION CHECKLIST					
SECTION A - CUSTOMER DATA					
1. PLANT Building 43	2. LOCATION Washington, DC	3. JOB NUMBER B43-106			
4. EQUIPMENT	5. SYSTEM DESIGNATION	6. DATE (YYYYMMDD) 20030112			
7. TEST EQUIPMENT		8. TESTED BY Charles Gray			
SECTION B - EQUIPMENT DATA					
9. SEPTIC TANK MANUFACTURER Various	10. MODEL NO 2200	11. SERIAL NO U K 534	12. FLOW RATING GPD 2000		
13. PUMP MANUFACTURER Gould	14. MODEL NO G270	15. SERIAL NO L M 987	16. FLOW RATING GPM 250		
17. SLUDGE DIGESTER A.T.C	18. MODEL NO 25	19. SERIAL NO H N 976	20. FLOW RATING GPD 2000		
SECTION C - VISUAL AND MECHANICAL INSPECTION					
21. CHECKPOINT	COND*	NOTES	CHECKPOINT	COND*	NOTES
EXTERIOR OF EQUIPMENT	A		BRACING	A	
COMPLETENESS OF ASSEMBLY	A		LABELING AND TAGGING	A	
EQUIPMENT ROTATION	A		TIGHTNESS OF BOLTED CONNECTIONS	A	
ELECTRICAL/MECHANICAL INTERLOCKS	A		LEAKS, LINE LOOKAGES	A	
SAFETY INTERLOCKS	A		WORKING SPACE	A	
INSTRUMENTS	A		ANCHORAGE	A	
PROPER GROUNDING	A		INSTALLATION AND LINE SLOPE	A	
PROPER INSULATION	A		COMPARISON TO DRAWINGS	A	
PROPER LUBRICATION	A		CONTROL SYSTEM	A	
EQUIPMENT IDENTIFICATION	A				
SECTION D - CALIBRATION AND SET POINT					
22	DESCRIPTION				NOTES
SENSORS	Check against standard and proper operation				
CONTROLLERS	Check for full operation				
ACTUATORS	Check full operation range				
FLOW METERS	Check against standard and proper operation				
MONITORING EQUIPMENT	Compare reading with manual readings				
SAMPLING EQUIPMENT	Check for cross contamination and completeness of package				
METERING PUMPS	Check for accuracy and compare to standard				
SECTION E - SYSTEM TESTS					
23	PASS	FAIL	COMMENTS		NOTES
FLOW	X				
DIGESTER OFF GAS	X				
EFFLUENT SAMPLE TESTS	X				
SYSTEM TEST	X				
24. NOTES					
*CONDITION: A= ACCEPTABLE; R= NEEDS REPAIR, REPLACEMENT OR ADJUSTMENT; C= CORRECTED; NA= NOT APPLICABLE					

Figure 9-6 Sewage Treatment System Inspection Checklist

Table 9-1 Possible Failures and Corrective Actions for Water Supply, Water Treatment and Sewage Treatment System(s)

	Areas to Check
General Controls	
Devices will not close/trip	Check mechanical alignment of limit switches Check interlocks and safeties Check relay and protective device settings and operation Check for mis-wired circuits Check the control circuit Check controller set point
Devices trip inadvertently	Check relay and protective device settings and operation Check for mis-wired circuits Check the control circuit Check for system overload or short Check grounds

Water supply and treatment systems	
Water will not flow	Check city water supply pressure Check filters and strainer Check interlocks, safeties Check for closed shut off valves Check pressure regulator setting
Poor water quality	Check for correct chemicals Check for correct quantity of chemicals added

Sewage treatment systems	
Will not start or shuts down	Check PLC and program Check power supply Check power supply to pumps and equipment Check controls, switches, starters, and disconnects Check controller set point Check sensors, actuators, and indicators Check safeties and interlocks
Sewage, sludge or water will not flow or backs up	Check power supply to pumps and equipment Check check-valve installation direction Check motor rotation and ampere load Check controls, switches, starters, and disconnects Check controller Check safeties and interlocks Check for clogged or stopped-up waste, drain, or vent piping Check septic tank for clogged inlet or discharge lines
Odor coming from the system or improper effluent quality	Check PLC Check controls, sensors and actuators Check chemical metering pumps Check trickling spray bars for proper spray pattern Check sludge levels Check vents Check gas collection system Check influent for toxic material, grease, bleach, gasoline, etc. Check aeration rates

Terms

Acceptance

When a system's readiness for operation has been demonstrated, verified, documented, and authorized.

Acceptance test

Functional performance test has replaced this terminology.

Authority having jurisdiction

An individual designated by government, the insuring institution and/or the company, who has knowledge of company operations, fire protection systems, and liability to life and property and who has the authority to stop operation of the facility when certain fire protection requirements are not met.

Commissioning

The systematic process of verifying, documenting, and ensuring that the systems in a new facility are designed, installed, functionally tested, and capable of being operated and maintained to perform according to the original design intent and owners' requirements. The process begins in the facilities program phase and progresses through design, construction/start-up, functional performance testing, and post functional performance phases, and lasts at least one year after project-closeout. Commissioning activities include training of operations and maintenance staff. During commissioning, functional performance tests and deferred functional performance tests are conducted on each system. These tests require written authorization for the systems to be accepted as ready for operation in the commissioning process. The commissioning process can be applied throughout the life of the facility (see recommissioning). Commissioning requires the participation of all parties involved in the facility delivery cycle from the program phase to the post acceptance phase.

Deferred functional performance tests

Functional performance tests which cannot be accomplished immediately and need to be deferred to a later time because of seasonal reasons, lack of occupancy, deficiencies in other systems, or structures impacting the system under consideration or other reasons. A comprehensive acceptance test schedule including deferred acceptance tests should be developed as part of the acceptance test plan.

Design basis document

All information necessary to accomplish the design intent, including weather data, interior environmental criteria, other pertinent design assumptions, cost goals, and references to applicable codes, standards, regulations, and guidelines.

Design intent

A detailed explanation of the ideas, concepts, and criteria that are defined by the owner to be important. This typically is an expansion of the information provided in the owner's program.

Final acceptance

When all requirements of the commissioning process/plan have been completely satisfied, documented, and authorized as accepted. At this point all of the systems in a facility are deemed ready for operation. Final acceptance occurs at the completion of the post acceptance period and may take one year in duration.

Functional performance test

The full range of checks and tests carried out to determine whether all components, subsystems, systems, and interfaces between systems function in accordance with the contract documents. In this context, "function" includes all modes and sequences of control operation, all interlocks, and conditional control responses and all specified responses during design day and emergency conditions

Post acceptance

The period of time occurring after project-closeout and before final acceptance. The post acceptance period may last for one year. It includes time for remaining or all deferred acceptance tests and the guarantee/warranty period.

Pre-Functional Performance Test

A series of tests for specified equipment or systems, which determine that the systems are installed correctly, start up, and are prepared for the functional performance tests. Often these tests are in a checklist format. The pre-functional test checklists may be completed as part of the normal contractor start-up test

Project-closeout

The point in time when the systems are considered acceptable for the owner and/or his operating and maintaining contractor (O & M) take over operation of the facility and its systems. At this time some or all deferred acceptance tests and guarantee/warranty work will remain to be completed. The post acceptance period begins at project-closeout.

Re-commissioning

A detailed condition assessment/retesting of an existing facilities' systems. During re-commissioning, functional performance tests are conducted on systems to establish acceptability. Re-commissioning requires subsequent "tune-ups" and fixes to bring systems back to design or current operating requirements. It includes all aspects of commissioning. Re-commissioning can occur only if a building or system had been previously commissioned. Re-commissioning involves the continued adjustment, optimization, and modification of systems to meet specified requirements. It includes updating documentation resulting from minor set point adjustments, system maintenance and calibration, major system modifications, and provides for ongoing training of operations and maintenance personnel. As in commissioning, re-commissioning requires authorization of satisfactorily completed tests for the systems to be considered acceptable and ready for operation.

Retro-commissioning

A detailed condition assessment/testing of an existing facilities systems, after the facility has been in operation and for which no commissioning activities have been conducted. Retro-commissioning requires all commissioning activities be performed and may require field work for preparation of drawings and documentation of equipment specifications.

Systems Manual

A document developed for a system that includes as-built drawings, equipment specifications, and equipment manuals which include installation instructions, operating instructions, maintenance instructions, and approvals from fire department inspectors, city, state, regulatory, and insurance officials. The system manual also includes pertinent information gathered during the commissioning process such as a copy of the signed commissioning sign-off sheet, a table of contents, and a list of all items in the manual.

HEATING WATER SYSTEM INSPECTION CHECKLIST						
SECTION A - CUSTOMER DATA						
1. PLANT		2. LOCATION		3. JOB NUMBER		
4. EQUIPMENT		5. HEATING WATER LOOP DESIGNATION		6. DATE (YYYYMMDD)		
7. TEST EQUIPMENT				8. TESTED BY		
SECTION B - EQUIPMENT DATA						
9. BOILER MANUFACTURER		10. MODEL NO	11. SERIAL NO		12. BTU RATING	
13. PUMP MANUFACTURER		14. MODEL NO	15. SERIAL NO		16. RATED FLOW	
17. HP @ RPM		18. RATED NPSH		19. RATED PRESSURE		
SECTION C - VISUAL AND MECHANICAL INSPECTION						
20	CHECK POINT	COND*	NOTES	CHECK POINT	COND*	NOTES
	EXTERIOR OF EQUIPMENT			EQUIPMENT IDENTIFICATION		
	COMPLETENESS OF ASSEMBLY			BRACING		
	EQUIPMENT ROTATION			LABELING AND TAGGING		
	ELECTRICAL/MECHANICAL			SAFETY INTERLOCKS		
	INSTRUMENTS			WORKING SPACE		
	PROPER GROUNDING			ANCHORAGE		
	PROPER INSULATION			SYSTEM FLUSHED AND CLEANED		
	TIGHTNESS OF BOLTED			COMPARISON TO DRAWINGS		
	PROPER LUBRICATION			CONTROL SYSTEM		
	WATER TREATMENT			FUEL SYSTEM		
SECTION D - CALIBRATION AND SET POINT						
2	DESCRIPTION					NOTES
	SENSORS					
	CONTROLLERS					
	ACTUATORS					
	RELIEF VALVES CHECKED					
	FUEL SAFETY VALVES					
SECTION E - HYDRONIC SYSTEM TESTS						
2	OPERATING MODES	TEMPERATURES	PRESSURES	FLOWS	LEVELS	NOTES
	BOILER					
	PUMP					
	HYDROSTATIC TEST					
	BALANCE TEST					
	HEATING COIL NUMBER					
	CONTROL VALVES					
	SYSTEM TEST					
23. NOTES						
*CONDITION: A = ACCEPTABLE; R= NEEDS REPAIR, REPLACEMENT OR ADJUSTMENT; C = CORRECTED; NA =NOT APPLICABLE						

CHILLED WATER SYSTEM INSPECTION CHECKLIST

SECTION A - CUSTOMER DATA

1. PLANT	2. LOCATION	3. JOB NUMBER
4. EQUIPMENT	5. COOLING WATER LOOP DESIGNATION	6. DATE (YYYYMMDD)
7. TEST EQUIPMENT		8. TESTED BY

SECTION B - EQUIPMENT DATA

9. CHILLER MANUFACTURER	10. MODEL NO	11. SERIAL NO	12. BTU RATING
13. PUMP MANUFACTURER	14. MODEL NO	15. SERIAL NO	16. RATED FLOW
17. HP @ RPM	18. RATED NPSH	19. RATED PRESSURE	

SECTION C - VISUAL AND MECHANICAL INSPECTION

2 0	CHECK POINT	COND*	NOTES	CHECK POINT	COND*	NOTES
	EXTERIOR OF EQUIPMENT			EQUIPMENT IDENTIFICATION		
	COMPLETENESS OF ASSEMBLY			BRACING		
	EQUIPMENT ROTATION			LABELING AND TAGGING		
	ELECTRICAL/MECHANICAL INTERLOCKS			SAFETY INTERLOCKS		
	INSTRUMENTS			WORKING SPACE		
	PROPER GROUNDING			ANCHORAGE		
	PROPER INSULATION			SYSTEM FLUSHED AND CLEANED		
	TIGHTNESS OF BOLTED CONNECTIONS			COMPARISON TO DRAWINGS		
	PROPER LUBRICATION			CONTROL SYSTEM		
	REFRIGERANT INSTALLED			WATER TREATMENT INSTALLED		

SECTION D - CALIBRATION AND SET POINT

2	DESCRIPTION	NOTES
	SENSORS	
	CONTROLLERS	
	ACTUATORS	
	RELIEF VALVES CHECKED	

SECTION E - HYDRONIC SYSTEM TESTS

2	OPERATING MODES	TEMPERATURES	PRESSURES	FLOWS	LEVELS	NOTES
	CHILLER					
	PUMP					
	HYDROSTATIC TEST					
	BALANCE TEST					
	COOLING COIL NUMBER					
	EXPANSION TANK/AIR SEPARATOR					
	CONTROL VALVES					
	SYSTEM TEST					

23. NOTES

*CONDITION: A = ACCEPTABLE; R= NEEDS REPAIR, REPLACEMENT OR ADJUSTMENT; C = CORRECTED; NA =NOT APPLICABLE

VENTILATION SYSTEM INSPECTION CHECKLIST

SECTION A - CUSTOMER DATA

1. PLANT	2. LOCATION	3. JOB NUMBER
4. EQUIPMENT	5. AIR LOOP DESIGNATION	6. DATE (YYYYMMDD)
7. TEST EQUIPMENT		8. TESTED BY

SECTION B - EQUIPMENT DATA

9. FAN MANUFACTURER	10. MODEL NO	11. SERIAL NO	12. RATED FLOW
13. FAN TYPE	14. HP @ RPM	15. RATED PRESSURE	

SECTION C - VISUAL AND MECHANICAL INSPECTION

1 6 .	CHECK POINT	COND*	NOTES	CHECK POINT	COND*	NOTES
	EXTERIOR OF EQUIPMENT			EQUIPMENT IDENTIFICATION		
	COMPLETENESS OF ASSEMBLY			BRACING		
	EQUIPMENT ROTATION			LABELING AND TAGGING		
	ELECTRICAL/MECHANICAL INTERLOCKS			SAFETY INTERLOCKS		
	INSTRUMENTS			WORKING SPACE		
	PROPER GROUNDING			ANCHORAGE		
	PROPER INSULATION			SYSTEM CLEANED		
	TIGHTNESS OF BOLTED CONNECTIONS			COMPARISON TO DRAWINGS		
	PROPER LUBRICATION			CONTROL SYSTEM		
	CONDENSATE DRIP PANS			FILTERS		

SECTION D - CALIBRATION AND SET POINT

1	DESCRIPTION	NOTES
	SENSORS	
	CONTROLLERS	
	ACTUATORS	
	FIRE DAMPERS CHECKED	
	SMOKE DAMPERS CHECKED	

SECTION E - SYSTEM TESTS

1	OPERATING MODES	TEMPERATURES	PRESSURES	FLOWS	LEVELS	NOTES
	FAN					
	DUCT LEAK TEST					
	AIR BALANCE TEST					
	COIL NUMBER					
	COIL NUMBER					
	CONTROL DAMPERS					
	SYSTEM TEST					

19. NOTES

*CONDITION: A = ACCEPTABLE; R= NEEDS REPAIR, REPLACEMENT OR ADJUSTMENT; C = CORRECTED; NA =NOT APPLICABLE

DIESEL FUEL SYSTEM INSPECTION CHECKLIST

SECTION A - CUSTOMER DATA						
1. PLANT	2. LOCATION	3. JOB NUMBER				
4. EQUIPMENT	5. SYSTEM DESIGNATION	6. DATE (YYYYMMDD)				
7. TEST EQUIPMENT				8. TESTED BY		
SECTION B - EQUIPMENT DATA						
9. PUMP MANUFACTURER	10. MODEL NO	11. SERIAL NO		12. FLOW RATING GPM		
13. TYPE		14. HP @ RPM		15. PRESSURE RATING PSIG		
16. HEATER MANUFACTURER	17. MODEL NO	18. SERIAL NO		19. FLOW RATE GPM		
20. COOLER MANUFACTURER	21. MODEL NO	22. SERIAL NO		23. FLOW RATE GPM		
SECTION C - VISUAL AND MECHANICAL INSPECTION						
2 4 . CHECK POINT	COND*	NOTES	CHECK POINT	COND*	NOTES	
EXTERIOR OF EQUIPMENT			EQUIPMENT IDENTIFICATION			
COMPLETENESS OF ASSEMBLY			BRACING			
EQUIPMENT ROTATION			LABELING AND TAGGING			
ELECTRICAL/MECHANICAL INTERLOCKS			SAFETY INTERLOCKS			
INSTRUMENTS			WORKING SPACE			
PROPER GROUNDING			ANCHORAGE			
PROPER INSULATION			LEAKS			
TIGHTNESS OF BOLTED CONNECTIONS			COMPARISON TO DRAWINGS			
PROPER LUBRICATION			CONTROL SYSTEM			
SECTION D - CALIBRATION AND SET POINT						
2	DESCRIPTION				NOTES	
SENSORS						
CONTROLLERS						
ACTUATORS						
SECTION E - DIESEL FUEL SYSTEM TESTS						
2	OPERATING MODES	TEMPERATURES	PRESSURES	FLOWS	LEVELS	NOTES
PUMP						
HEATER						
COOLER						
ENGINE						
HYDROSTATIC TEST						
SYSTEM TEST						
27. NOTES						
*CONDITION: A = ACCEPTABLE; R= NEEDS REPAIR, REPLACEMENT OR ADJUSTMENT; C = CORRECTED; NA =NOT APPLICABLE						

LUBE OIL SYSTEM INSPECTION CHECKLIST

SECTION A - CUSTOMER DATA						
1. PLANT	2. LOCATION			3. JOB NUMBER		
4. EQUIPMENT	5. SYSTEM DESIGNATION			6. DATE (YYYYMMDD)		
7. TEST EQUIPMENT				8. TESTED BY		
SECTION B - EQUIPMENT DATA						
9. PUMP MANUFACTURER	10. MODEL NO	11. SERIAL NO		12. FLOW RATING GPM		
13. TYPE		14. HP @ RPM		5. PRESSURE RATING PSIG		
16. HEATER MANUFACTURER	17. MODEL NO	18. SERIAL NO		19. FLOW RATING GPM		
20. COOLER MANUFACTURER	21. MODEL NO	22. SERIAL NO		23. FLOW RATING GPM		
24. CENTRIFUGE MANUFACTURER	25. MODEL NO	26. SERIAL NO		27. FLOW RATING GPM		
SECTION C - VISUAL AND MECHANICAL INSPECTION						
2	8	CHECK POINT	COND*	NOTES	CHECK POINT	COND* NOTES
		EXTERIOR OF EQUIPMENT			EQUIPMENT IDENTIFICATION	
		COMPLETENESS OF ASSEMBLY			BRACING	
		EQUIPMENT ROTATION			LABELING AND TAGGING	
		ELECTRICAL/MECHANICAL INTERLOCKS			SAFETY INTERLOCKS	
		INSTRUMENTS			WORKING SPACE	
		PROPER GROUNDING			ANCHORAGE	
		PROPER INSULATION			LEAKS	
		TIGHTNESS OF BOLTED CONNECTIONS			COMPARISON TO DRAWINGS	
		PROPER LUBRICATION			CONTROL SYSTEM	
SECTION D - CALIBRATION AND SET POINT						
2	DESCRIPTION					NOTES
	SENSORS					
	CONTROLLERS					
	ACTUATORS					
SECTION E - LUBE SYSTEM TESTS						
3	OPERATING MODES	TEMPERATURES	PRESSURES	FLOWS	LEVELS	NOTES
	PUMP					
	HEATER					
	COOLER					
	ENGINE					
	HYDROSTATIC TEST					
	SYSTEM TEST					
31. NOTES						
*CONDITION: A = ACCEPTABLE; R= NEEDS REPAIR, REPLACEMENT OR ADJUSTMENT; C = CORRECTED; NA =NOT APPLICABLE						

COMPRESSED AIR SYSTEM INSPECTION CHECKLIST

SECTION A - CUSTOMER DATA

1. PLANT	2. LOCATION	3. JOB NUMBER
4. EQUIPMENT	5. SYSTEM DESIGNATION	6. DATE (YYYYMMDD)
7. TEST EQUIPMENT		8. TESTED BY

SECTION B - EQUIPMENT DATA

9. COMPRESSOR MANUFACTURER	10. MODEL NO	11. SERIAL NO	12. FLOW RATING CFM
13. TYPE	14. HP @ RPM		15. PRESSURE RATING PSIG
16. DRYER MANUFACTURER	17. MODEL NO	18. SERIAL NO	19. EXIT FLOW RATE @ DP°F
20. OIL/WATER SEPARATOR MFG	21. MODEL NO	22. SERIAL NO	23. FLOW RATE CFM

SECTION C - VISUAL AND MECHANICAL INSPECTION

2 4 . CHECK POINT	COND*	NOTES	CHECK POINT	COND*	NOTES
EXTERIOR OF EQUIPMENT			EQUIPMENT IDENTIFICATION		
COMPLETENESS OF ASSEMBLY			BRACING		
EQUIPMENT ROTATION			LABELING AND TAGGING		
ELECTRICAL/MECHANICAL INTERLOCKS			SAFETY INTERLOCKS		
INSTRUMENTS			WORKING SPACE		
PROPER GROUNDING			ANCHORAGE		
PROPER INSULATION			CONDENSATE DRIP LEGS		
TIGHTNESS OF BOLTED CONNECTIONS			COMPARISON TO DRAWINGS		
PROPER LUBRICATION			CONTROL SYSTEM		

SECTION D - CALIBRATION AND SET POINT

2	DESCRIPTION	NOTES
SENSORS		
CONTROLLERS		
ACTUATORS		
RELIEF VALVES CHECKED		

SECTION E - COMPRESSED AIR SYSTEM TESTS

2	OPERATING MODES	TEMPERATURES	PRESSURES	FLOWS	LEVELS	NOTES
AIR COMPRESSOR						
AIR DRYER						
OIL/WATER SEPARATOR						
PRESSURE TEST						
FILTERS, TRAPS						
SYSTEM TEST						

27. NOTES

*CONDITION: A = ACCEPTABLE; R= NEEDS REPAIR, REPLACEMENT OR ADJUSTMENT; C = CORRECTED; NA =NOT APPLICABLE

WET PIPE SPRINKLER SYSTEM AND FIRE DETECTION SYSTEM INSPECTION CHECKLIST

SECTION A - CUSTOMER DATA

1. PLANT	2. LOCATION	3. JOB NUMBER
4. EQUIPMENT	5. SYSTEM DESIGNATION	6. DATE (YYYYMMDD)
7. TEST EQUIPMENT	8. TESTED BY	

SECTION B - EQUIPMENT DATA

9. FIRE DETECTION CONTROL PANEL AND SYSTEM MANUFACTURER	10. MODEL NO	11. SERIAL NO	12. LOCATION
13. FIRE RISER	14. LOCATION		

SECTION C - VISUAL AND MECHANICAL INSPECTION

1 5 .	CHECK POINT	COND*	NOTES	CHECK POINT	COND*	NOTES
	EXTERIOR OF EQUIPMENT			EQUIPMENT IDENTIFICATION		
	COMPLETENESS OF ASSEMBLY			FREEZE PROTECT, VENTS AND DRAINS		
	CONTROL SYSTEM DISPLAY			LABELING AND TAGGING		
	ELECTRICAL/MECHANICAL INTERLOCKS			WALLS AND OBJECTS NEAR SPRINKLER HEADS		
	SAFETY INTERLOCKS			MATERIALS BEING STORED		
	INSTRUMENTS AND ALARMS			OCCUPANCY		
	PROPER GROUNDING			PAD LOCKS		
	PROPER INSULATION			ACCESS NEAR RISER, PANEL AND FDC		
	LOCATION OF SPRINKLER HEADS			ANCHORAGE AND PIPE HANGERS		
	CONDITION OF SPRINKLER HEADS			COMPARISON TO DRAWINGS		

SECTION D - CALIBRATION AND SET POINT

1	DESCRIPTION	NOTES
GAUGES		
BATTERY AND CHARGER		

SECTION E - SYSTEM TESTS

1	OPERATING MODES	TEMPERATURES	PRESSURES	FLOWS	LEVELS	NOTES
HYDROSTATIC TEST						
ALARM/STROBES						
FLOW AND TAMPER SWITCHES						
PULL STATIONS						
FLOW TEST						
SYSTEM TEST						

18. NOTES

*CONDITION: A = ACCEPTABLE; R = NEEDS REPAIR, REPLACEMENT OR ADJUSTMENT; C = CORRECTED; NA =NOT APPLICABLE

LIFTING AND MOVING DEVICES INSPECTION CHECKLIST

SECTION A - CUSTOMER DATA

1. PLANT	2. LOCATION	3. JOB NUMBER
4. EQUIPMENT	5. SYSTEM DESIGNATION	6. DATE (YYYYMMDD)
7. TEST EQUIPMENT		8. TESTED BY

SECTION B - EQUIPMENT DATA

9. CRANE MANUFACTURER	10. MODEL NO	11. SERIAL NO	12. LOCATION	13. CAPACITY
14. HOIST MANUFACTURER	15. MODEL NO	16. SERIAL NO	17. LOCATION	18. CAPACITY

SECTION C - VISUAL AND MECHANICAL INSPECTION

1 9 . CHECK POINT	COND*	NOTES	CHECK POINT	COND*	NOTES
EXTERIOR OF EQUIPMENT			EQUIPMENT IDENTIFICATION		
COMPLETENESS OF ASSEMBLY			EQUIPMENT CONDITION		
CONTROL SYSTEM DISPLAY			CAPACITY IDENTIFICATION		
SAFETY INTERLOCKS			LABELING AND TAGGING		
ELECTRICAL/MECHANICAL INTERLOCKS			END AND/OR SWING STOPS IN PLACE		
INSTRUMENTS AND ALARMS			ACCESS		
PROPER GROUNDING			ANCHORAGE		
PROPER INSULATION			COMPARISON TO DRAWINGS		
CABLE CHAIN CONDITION			ALIGNMENT		

SECTION D - CALIBRATION AND SET POINT

2	DESCRIPTION	NOTES
LIMIT SWITCHES		

SECTION E - LIFTING AND MOVING DEVICES EQUIPMENT TESTS

2	PASS	FAIL	COMMENTS	NOTES
LOAD TEST				
TEST ALL BRAKES				
SAFETIES TEST				
ALARMS				
CABLE/HOOK INSPECTION				
OPERATIONAL TEST				

22. NOTES

*CONDITION: A = ACCEPTABLE; R= NEEDS REPAIR, REPLACEMENT OR ADJUSTMENT; C = CORRECTED; NA =NOT APPLICABLE

ELEVATOR INSPECTION CHECKLIST					
SECTION A - CUSTOMER DATA					
1. PLANT	2. LOCATION		3. JOB NUMBER		
4. EQUIPMENT	5. SYSTEM DESIGNATION		6. DATE (YYYYMMDD)		
7. TEST EQUIPMENT			8. TESTED BY		
SECTION B - EQUIPMENT DATA					
9. ELEVATOR MANUFACTURER	10. MODEL NO	11. SERIAL NO	12. LOCATION	13. CAPACITY	
14. DRIVE MANUFACTURER	15. MODEL NO	16. SERIAL NO	17. LOCATION	18. CAPACITY	
SECTION C - VISUAL AND MECHANICAL INSPECTION					
1 9 . CHECK POINT	COND*	NOTES	CHECK POINT	COND*	NOTES
EXTERIOR OF EQUIPMENT			EQUIPMENT IDENTIFICATION		
COMPLETENESS OF ASSEMBLY			EQUIPMENT CONDITION		
CONTROL SYSTEM DISPLAY			CAPACITY IDENTIFICATION		
SAFETY INTERLOCKS			LABELING AND TAGGING		
ELECTRICAL/MECHANICAL INTERLOCKS			ALARM, TELEPHONE, INTERCOM		
INSTRUMENTS AND ALARMS			ACCESS		
PROPER GROUNDING			ANCHORAGE		
PROPER INSULATION			COMPARISON TO DRAWINGS		
ELEVATOR DOORS			ALIGNMENT		
ENTRANCE WAY			HYDRAULIC LEAKS		
CABLE CHAIN CONDITION					
SECTION D - CALIBRATION AND SET POINT					
2	DESCRIPTION			NOTES	
HYDRAULIC PRESSURE					
DOOR POSITION					
SECTION E - LIFTING AND MOVING DEVICES EQUIPMENT TESTS					
2	PASS	FAIL	COMMENTS	NOTES	
LOAD TEST					
TEST ALL BRAKES					
SAFETIES TEST					
ALARMS					
OPERATIONAL TEST					
22. NOTES					
*CONDITION: A = ACCEPTABLE; R= NEEDS REPAIR, REPLACEMENT OR ADJUSTMENT; C = CORRECTED; NA =NOT APPLICABLE					

WATER SUPPLY AND TREATMENT SYSTEM INSPECTION CHECKLIST

SECTION A - CUSTOMER DATA		
1. PLANT	2. LOCATION	3. JOB NUMBER
4. EQUIPMENT	5. SYSTEM DESIGNATION	6. DATE (YYYYMMDD)
7. TEST EQUIPMENT		8. TESTED BY

SECTION B - EQUIPMENT DATA			
9. BACK FLOW PREVENTER MANUFACTURER	10. MODEL NO	11. SERIAL NO	12. FLOW RATING
13. PRESSURE REGULATOR	14. MODEL NO	15. SERIAL NO	16. FLOW RATING
17. CHEMICAL FEED POT MANUFACTURER	18. MODEL NO	19. SERIAL NO	20. CAPACITY

SECTION C - VISUAL AND MECHANICAL INSPECTION					
2 1 . CHECK POINT	COND*	NOTES	CHECK POINT	COND*	NOTES
EXTERIOR OF EQUIPMENT			IDENTIFICATION		
COMPLETENESS OF ASSEMBLY			BRACING/SUPPORTS		
INTERLOCKS			LABELING AND TAGGING		
INSTRUMENTS			WORKING SPACE		
PROPER GROUNDING			ANCHORAGE		
PROPER INSULATION			COMPARISON TO DRAWINGS		
TIGHTNESS OF BOLTED CONNECTIONS			WELD INSPECTION		
LEAKS					

SECTION D - CALIBRATION AND SETTING		
2 2 .	DESCRIPTION	NOTES
BACK FLOW PREVENTER		
PRESSURE REGULATOR		
GAGES		
LIMIT SWITCHES AND LINKAGES		

SECTION E - SYSTEM TESTS				
2 3 .	PASS	FAIL	COMMENTS	NOTES
WATER QUALITY				
HYDROSTATIC TEST				
STRAINERS/FILTERS				
SYSTEM TEST				

24. NOTES

*CONDITION: A = ACCEPTABLE; R= NEEDS REPAIR, REPLACEMENT OR ADJUSTMENT; C = CORRECTED; NA =NOT APPLICABLE

SEWAGE TREATMENT SYSTEM INSPECTION CHECKLIST

SECTION A - CUSTOMER DATA

1. PLANT	2. LOCATION	3. JOB NUMBER
4. EQUIPMENT	5. SYSTEM DESIGNATION	6. DATE (YYYYMMDD)
7. TEST EQUIPMENT		8. TESTED BY

SECTION B - EQUIPMENT DATA

9. SEPTIC TANK MANUFACTURER	10. MODEL NO	11. SERIAL NO	12. FLOW RATING GPD
13. PUMP MANUFACTURER	14. MODEL NO	15. SERIAL NO	16. FLOW RATING GPM
17. SLUDGE DIGESTER	18. MODEL NO	19. SERIAL NO	20. FLOW RATING GPD

SECTION C - VISUAL AND MECHANICAL INSPECTION

21.	CHECK POINT	COND*	NOTES	CHECK POINT	COND*	NOTES
	EXTERIOR OF EQUIPMENT			BRACING		
	COMPLETENESS OF ASSEMBLY			LABELING AND TAGGING		
	EQUIPMENT ROTATION			TIGHTNESS OF BOLTED CONNECTIONS		
	ELECTRICAL/MECHANICAL INTERLOCKS			LEAKS, LINE BLOCKAGES		
	SAFETY INTERLOCKS			WORKING SPACE		
	INSTRUMENTS			ANCHORAGE		
	PROPER GROUNDING			INSTALLATION AND LINE SLOPE		
	PROPER INSULATION			COMPARISON TO DRAWINGS		
	PROPER LUBRICATION			CONTROL SYSTEM		
	EQUIPMENT IDENTIFICATION					

SECTION D - CALIBRATION AND SET POINT

22	DESCRIPTION	NOTES
SENSORS		
CONTROLLERS		
ACTUATORS		
FLOW METERS		
MONITORING EQUIPMENT		
SAMPLING EQUIPMENT		
METERING PUMPS		

SECTION E - SYSTEM TESTS

23	PASS	FAIL	COMMENTS	NOTES
FLOW				
DIGESTER OFF GAS				
EFFLUENT SAMPLE TESTS				
SYSTEM TEST				

24. NOTES

*CONDITION: A = ACCEPTABLE; R= NEEDS REPAIR, REPLACEMENT OR ADJUSTMENT; C = CORRECTED; NA =NOT APPLICABLE