



**PDHonline Course M486 (2 PDH)**

---

# **Selection and Sizing of Air Release Valves**

*Instructor: A. Bhatia, B.E.*

**2020**

**PDH Online | PDH Center**

5272 Meadow Estates Drive  
Fairfax, VA 22030-6658  
Phone: 703-988-0088  
[www.PDHonline.com](http://www.PDHonline.com)

An Approved Continuing Education Provider

## Selection and Sizing of Air Release Valves

*A. Bhatia, B.E.*

### Introduction

Free air can be found in most piping systems and fittings. Pipes considered empty before use are really full of air and the filling a pipeline requires that the air be pushed out by the water. Air entrapped in pipelines is an invisible culprit to many problems such as poor flow, water hammer problems, poor pressure control, damaged pumps and broken pipes. Control of air in the pipelines is thus very important.

Some of the hindrances, problems, and dangers attributed to the presence of air in pressurized pipeline systems are:

1. Inadequate supply of water. Air trapped in a pipeline can reduce or even completely stop the flow of water in the line. This is particularly a critical problem in pipelines that operate under very low heads or in long lengths.
2. Entrained air diminishes pump efficiency and cause energy losses;
3. Water Hammer, pulsations, dead heading... even can damage pipes and pump;
4. Corrosion and cavitation;
5. Inaccurate readings in meters and automatic metering valves. Serious damage to spinning internal parts of meters, metering valves may occur;
6. Physical danger to operators from air-blown flying parts and from very strong streams of high velocity, escaping air.

There are situations where air has to be taken in, primarily for efficient drainage, for vacuum protection, and/or for surge protection. Some of the problems and damages due to the absence of air, when and where it is needed, are:

1. Vacuum enhanced problems and damages;
2. Pipe or accessory collapse, due to sub-atmospheric (negative) pressures;

3. In some cases, the absence of air cushion can increase the damages of surge and slam phenomena.

Engineers have relied on various options such as concoctions of standpipes and various manual or automatic shutoff valves to deal with air - few worked well; some even created additional problems. The most efficient way to control air is by proper use of air valves that function by admitting large quantities of air when needed, and releasing air continuously in pressurized liquid conveyance systems.

### **How does air get into the system?**

Air or gas gets into a pipeline in three primary sources:

1. First during filling. As the pipeline is filled, much of the air will be pushed downstream and released through hydrants, faucets, and other mechanical apparatus. If a means for air escape is not provided, air will be trapped at high points in the pipeline.
2. Second the air is forced into the system by pumps or drawn into the pipe under vacuum conditions;
3. Thirdly the water itself contains about 2% air by volume. The dissolved air will come out of solution with a rise in temperature or a drop in pressure which will occur at high points due to the increase in elevation;
4. Four, when a pipeline is drained, air enters the line.

### **Effects of Trapped Air**

Air in pipes is in the form of bubbles. These air bubbles will generally migrate to the high points of a system. Velocity of water flow will move the bubbles up slope. Figure below illustrates what happens when air bubbles are trapped at a high point in a pipeline.

If provisions are not made to remove this air from high points, pockets of air will collect and grow in size. Air pocket growth will then gradually reduce the effective liquid flow area, creating a throttling effect as would a partially closed valve. In severe cases the air can create an air block that stops water flow. The rapid movement of the air pockets can be the main problem causing sudden violent changes in velocity. The velocity of flow changes rapidly because of

the fact that water is 800 times more dense than air. When larger air pockets are suddenly vented the result can be dangerous explosive burst; followed by abrupt change of the water.

In addition to the flow restriction, a dislodged pocket of air can cause surges or water hammer. Water hammer can damage equipment or loosen fittings and cause leakage. Finally, corrosion in the pipe material is accelerated when exposed to the air pocket, which can result in premature failure of the pipeline.

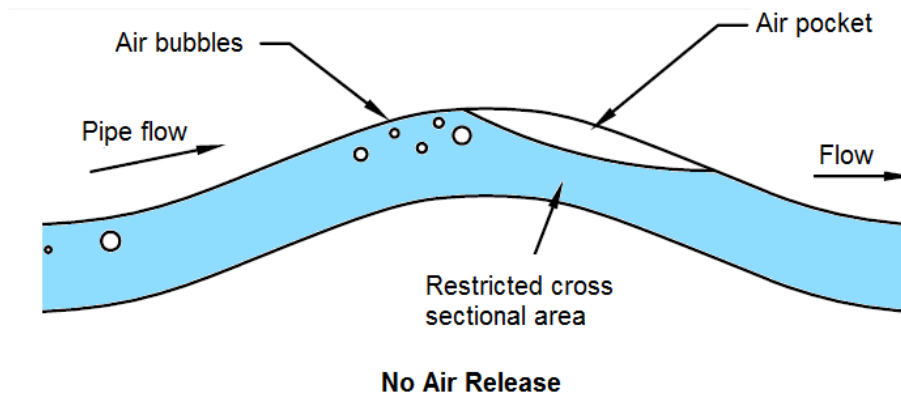

### Problem Areas

Air pockets are a frequent problem in very low flow, low pressure pipelines. When the velocity of water is very low, air bubbles do not get pushed out, even if the summit in the line is only one pipe diameter above the rest of the line. The air pockets also occur in the long pipelines operating under pressure (high head).

### What is the solution?

The solution to air control can be either of the following:

1. Install an open air vent at summits to control the entry and exhausting of air.
2. Install hydrants at all summits in the line so the air can be vented manually.
3. For pressurized line, minimize the number of summits in the line by meandering the pipeline along the contour to avoid high points.
4. Often the velocity of the liquid will remove air bubbles if the pipeline slopes upward to lodge at a high point. But, if the pipeline is fairly flat or the pipeline slopes downward,

the velocity may not be sufficient to keep the air pockets (bubbles) moving. Increasing the water velocity to the point the water "sweeps" out the air bubbles is critical.

5. Use the water pumping level well above the pump intake. This will avoid siphoning air along with the water into the pipeline.
6. Keep the bulk of the pipelines full if possible. Minimize refilling of the lines in order to avoid repeated trapping of air.
7. Lay pipe to grade in order to have fewer high points. Lay out the pipe so it is on either a constantly increasing or decreasing gradients. Experience indicates that minimum pipe diameter should be:
  - 1¼ inch nominal diameter for gradients over 1.0 percent.
  - 1½ inch nominal diameter for gradients from 0.5 to 1.0 percent.
  - 2 inch nominal diameter for gradients from 0.2 to 0.5 percent.

For gradients less than 0.2 percent, gravity flow systems are not recommended and where pipe of minimum size will not deliver the required flow, the size should be increased.

Today, most pipeline installations use a variety of automatic air valves at all points where air can collect along the pipeline.

### **What is an air valve?**

Air valves are hydro-mechanical devices which automatically vent small pockets of air as they accumulate at high points in a system while the system is operating and pressurized.

An air release valve has a small venting orifice that releases air entrained in water under pressure. The air release valve is normally-open and closes as soon as liquid rises in the system and lifts a float within the valve. The valve allows the rising liquid to force out air that occurs naturally in a piping system. Once the liquid rises and reaches pressure, the air release valve remains sealed until the system is depressurized. Depending on the application, it should be mounted at high points in the piping system, as well as the tank.

Air valves can open against internal pressure, because the internal lever mechanism multiplies the float force to be greater than the internal pressure. This greater force opens the orifice whenever air pockets collect in the valve. The orifice size generally varies between 1/16" and 3/8" depending on valve design and working pressure.

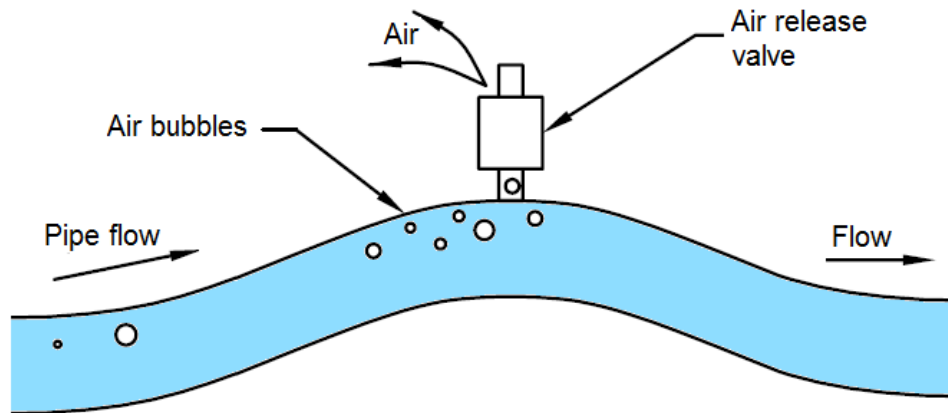

**With Air Release Valve**

Air release valves should be installed with an isolation valve to facilitate removal from the pipeline (should the valve fail or require maintenance) without having to shut the pipeline down.

### **Types of Air Valves**

Air valves in general are often misnamed as "Air release valves" or, less frequently, as "vacuum breakers". Actually, there are three basic types of air valves which are standardized in American Water Works Association (AWWA) Standard C512: Air Valves for Waterworks Service. They are:

1. Automatic Air Release valves with small orifice
2. Air & Vacuum Release valves with large orifice
3. Combination Air Release valves

Each of these types functions differently and serves different objectives.

### **AUTOMATIC AIR RELEASE VALVES WITH SMALL ORIFICE**

Air release valves, also called small orifice valves, are designed to automatically release small pockets of accumulated air from a pipeline while the system operates under pressure exceeding atmospheric pressure. These valves have much smaller orifices compared to the Air & vacuum valves and are designed to release small pockets of accumulated air while the pipeline operates under pressure. The orifice size generally varies between 1/16" and 3/8" depending on valve design and working pressure, although 1" or larger sizes are available.

### **How do they work?**

Air release valve has a small precision orifice in the range of 0.0625-in (1.6-mm) to 0.5-in (13-mm) and has a float and linkage mechanism, which triggers the opening the orifice upon sensing the air. In operation, as small quantities of air bubbles enter the valve, they will displace the liquid within the valve and lower its level in relation to the float. When the level of the liquid is lowered to where the float is no longer buoyant, the float will drop. This motion opens the valve seat and permits the air which has accumulated in the upper portions of the valve body to be exhausted to atmosphere. While the system is flowing and under pressure, air release valves continually and automatically exhaust the small quantities of air that would otherwise collect at system high points. Air Release valve should be installed at high points or at grade changes within the pipeline.

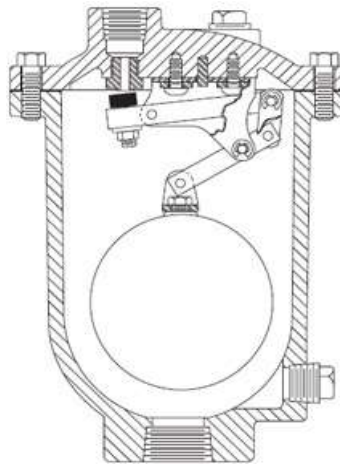

**Air Release Valve**

The Air Release Valve has the ability to open against internal pressure because it has a small orifice and a leverage mechanism which multiplies the force of the float. This force must be greater than the internal pressure across the orifice in order to open the orifice when a pocket

of air needs to be vented. This explains why, as the internal pressure **increases**, the orifice **decreases** in size to facilitate the valve opening.

### **Applications**

Air Release Valves are installed on water transmission lines and sewage force mains, at or slightly downstream of peaks and high points, often as part of a “Combination Air Valve”

An air release valve can be used between a vertical turbine pump and a power actuated pump check valve to prevent surges in the piping between the pump and the check valve. In this application, the opening of the check valve is delayed with a timer until the air release valve can discharge the air in the pump column to achieve a controlled 1-ft/sec to 2-ft/sec (0.3-m/sec to 0.6-m/sec) flow velocity in the pump column. For a 20-ft (6-m) lift, the delay time will be about 10 to 20 seconds. Because the valve has limited vacuum flow capacity, a timer is also needed to delay the pump restart so that the water level in the pump column has time to return to its original level.

**IMPORTANT NOTE:** Air release valves are intended to release air as it accumulates at high points during system operation. They are NOT recommended for vacuum protection or to vent large volumes of air when filling large diameter pipelines, because inherently ARVs have small orifices, usually less than 1/2” diameter - Air & vacuum Valves have much larger orifices for this purpose. When vacuum protection is necessary - use in conjunction with air & vacuum valves.

### **AIR & VACUUM VALVES WITH LARGE ORIFICE**

Air and vacuum valves also called large orifice valves, are designed to exhaust large quantities of air automatically during pipeline filling, and to admit large quantities of air when the internal pressure in the pipeline drops below atmospheric pressure. It functions only when the line is not under pressure. Once the pipeline is purged of air, the valve closes tight and does not open until the system is drained or a negative pressure occurs. It then opens, admitting large volumes of air into the pipeline to eliminate a vacuum condition.

**Note:** The large orifice air valves are usually called “kinetic air valves” in Europe and other parts of the world, and an “air & vacuum valves” in the United States and North America.

### **How do they work?**



In operation when the system is filled, a float in the valve rises with the water level to shut off the valve. The orifice will remain closed until the system is emptied. Upon the loss of pressure due to draining, line break or column separation, the float will drop and allow air to reenter the pipe. It is important to note that under normal operation, the float is held closed by the line pressure and will not relieve accumulated air. An air release valve is needed to relieve air during system operation.

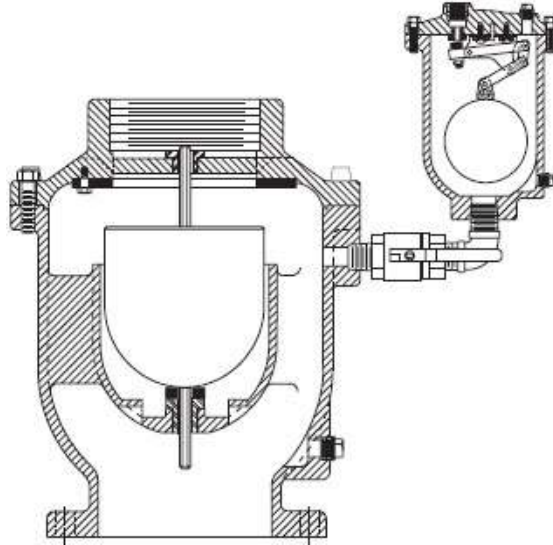

**An air & vacuum valve**

### **Design and Principle of Operation**

The design of the air & vacuum valve incorporates a specific ball diameter for a given valve size such that the aerodynamic force will hold the ball in the open position as air is moving across it but will be buoyed by the hydraulic action of rising water. This coupled with a proper angle of the cone at the valve's inlet provides an air & vacuum valve that is designed not to be blown shut regardless of pressure, at exit velocities approaching sonic velocity.

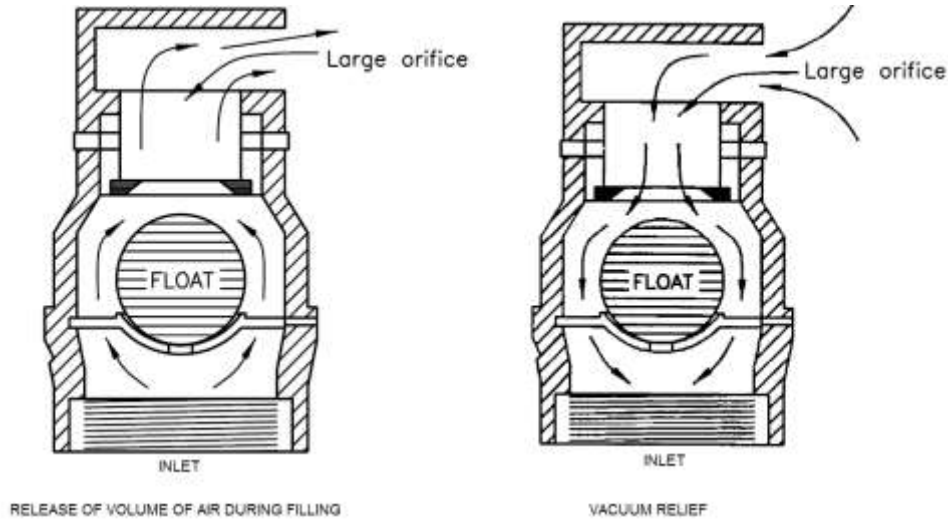

The valve is normally open and exposes a full size orifice. Since the rate of air discharge is a function of the pressure across the valve orifice, incoming liquid compresses the air until sufficient pressure develops to give the escaping air an exhaust rate equal to that of the liquid. Once all the air has been purged, liquid lifts the float ball, closing the orifice. Residual air pockets may enter the valve while the system is in operation, but the float will be held closed against the seat by the internal pressure. As soon as the internal pressure drops to near atmosphere (impending vacuum) the float drops and opens the valve, permitting an inflow of air to the system. Thus, a critical vacuum cannot form and the system is protected from damage.

Air & vacuum valves can be equipped with an anti-slam device, which controls the flow of water into the valve to reduce surges in the valve. The anti-slam device is useful at highpoints where column separation or rapid changes in velocity occur. Column separation can be predicted by computer transient analysis, but the following general guidelines can be used to help locate anti-slam devices:

1. When the flow velocity is greater than 8-ft/s (2.4-m/s), the surge potential can be as high as 400-psi (2760-kPa). Also, when the fill velocity exceeds 2-ft/s (0.6-m/s), high surges can result.
2. High points where a vacuum forms on shutoff will exhibit rapid flow reversal.
3. Systems where the time for the water column to reverse exceeds the critical time will see high surges even from small changes in velocity.

4. Fast closing pump discharge check valves may prevent slam but still cause line surges.
5. Systems with booster stations can see great fluctuations in line velocities on power failure.
6. If the pipeline discharge creates a siphon on shutdown, rapid flow reversal can be expected.

**Caution** - When the valve is equipped with an anti-slam device, the differential pressure may be as high as 5-psi (35-kPa). Higher differentials are not used because the possibility of water reaching the air & vacuum valve with excessive fluid velocities and to eliminate the noise associated with sonic velocities.

### **Applications**

The primary application for air & vacuum valves is on water transmission lines and sewage force mains. These are frequently installed on the discharge side of deep well turbine pumps between the pump and discharge check valve to exhaust large volumes of air from the system each time the pump starts and to break the vacuum when the pump stops.

The air & vacuum valve for well service and vertical turbine pump application should be equipped with a throttling device (3-in and smaller valves) or an anti-slam device (4-in and larger valves). These pumps start against an empty pump column and a closed pump check valve and therefore start rapidly and accelerate the fluid. The throttling device controls the air discharge rate so that the pressure surge caused by the pump water column reaching the closed pump check valve is minimized. The throttling device has a second independent vacuum port to allow air flow back into the line after pump shutdown so that the static suction water level can be restored without allowing a vacuum to form in the pump column.

### **COMBINATION AIR VALVES**

Combination air valves are designed to perform the same function as air & vacuum valves but, in addition, they will automatically release small pockets of air from the pipeline while under pressure, like an air release valve. It incorporates the features of both the Air & vacuum and air release valves into one unit. The large (air & vacuum) and the small (air release) orifices are both open during filling with the majority of the air is passes through the large orifice.

## **Why Use Combination Air Valves?**

While air release valves can exhaust the small pockets of air that collect in the pipeline while the system is pressurized, their orifice is usually not big enough to admit a sufficient quantity of air to prevent critical vacuum formation. On the other hand, air & vacuum valves have big orifices to purge large volumes of air at start-up and to admit large amounts of air during draining to prevent vacuum formation, but they cannot release the small, residual air pockets that form while in operation. Most applications for automatic air valves require air to be exhausted both at start-up and while operating and to incorporate vacuum protection during draining. Neither the air release nor the Air & vacuum valve can perform all three functions when used alone.

## **How do they work?**

A combination valve contains both a small air release orifice and a large air & vacuum port in one assembly. On smaller valves, usually less than 8-in (200-mm), the float and lever mechanism are contained in a single body design. On larger sizes, a dual body design consisting of an air release valve piped to an air & vacuum valve is furnished as a factory assembled unit.

The air & vacuum (large) and air release (small) orifices are normally open and both exhaust air during filling, with the great majority of the air passing through the large orifice. The rate of air discharge is a function of the pressure across the orifice. The rate at which air is discharged is a function of the differential pressure across the air & vacuum valve. During filling, incoming water compresses the air in the “empty” pipe until the pressure differential across the air valve is sufficient that air is discharged at the same volumetric rate as water is entering the pipe. After all the air has been purged, liquid enters the valve and lifts the floats and closes both orifices. While the large orifice remains closed, the small orifice reopens as necessary to release any air that collects in the valve after it has closed. As soon as the system pressure drops to atmospheric (impending vacuum) , both orifices open to allow air to flow through the valve into the system at the same volumetric rate at which the liquid is draining thus avoiding critical vacuum and damage to the pipe.

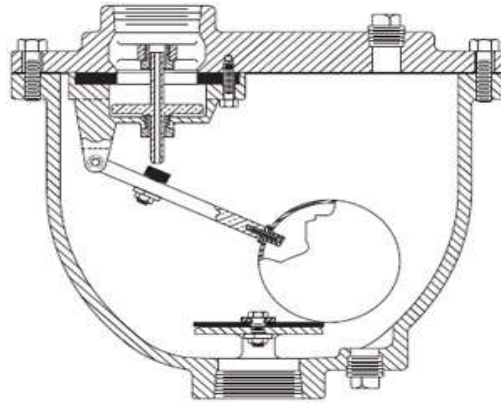

**A combination air valve**

Single body units have the advantage of being more compact and typically less costly. Dual body units are advantageous for air release valve sizing and maintenance because the air & vacuum valve is still in operation while the air release valve is isolated and under repair.

### **Applications**

Combination air valves are primarily used on water mains, transmission lines and sewage force mains. They are also used at the discharge of pumps, especially Deep Well Turbine Pumps, to control the ascent rate of the rising water column, and to vent the dissolved air that escapes from the liquid while the pump is running and to break the vacuum when the pump stops.

Some designers use only combination air valves on a pipeline because all air valve functions are included and a mistake in field installation will not leave the pipeline unprotected.

### **Where should these valves be located?**

Air valves are located at the high points of a fully pressurized pipeline and at the transition points in the hydraulic gradient; especially before and after steep slopes in the distribution system.

This is a very simplified description of the air valve location methodology, while efficient and effective air valve location planning is often quite complicated, yet important. Proper location of air valves in a pressurized liquid conveyance system can improve flow performance greatly, providing efficient, energy saving, dependable, and safe supply. Poor air valve location can cause problems, damage and hazards.

The AWWA – American Water Works Association recommends air valves at the following points along a pipeline:

1. High points: combination air valve.
2. Long horizontal runs: air release or combination valve at 1250-ft to 2500-ft (380-m to 760-m) intervals.
3. Long descents: combination air valve at 1250-ft to 2500-ft (380-m to 760-m) intervals.
4. Long ascents: air & vacuum valve at 1250-ft to 2500-ft (380-m to 760-m) intervals.
5. Decrease in an up slope: air & vacuum valve.
6. Increase in a down slope: combination air valve.

In addition:

1. Place in between a pump and check valve or normally closed control valve.
2. Adjacent to any quick closing valve and downstream of automatic control valves.

The AWWA, in their Manual of Water Supply Practices, M51 – “Air-Release, Air & vacuum, & Combination Air Valves”, adopted a sample pipeline profile similar to those of the American manufacturers.

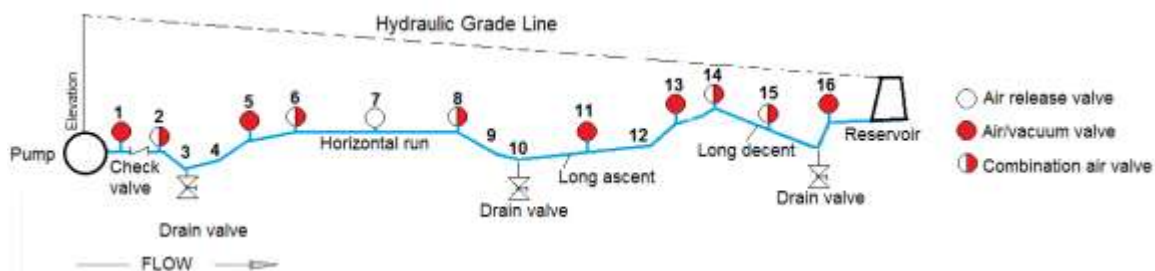

No.	Description	Recommended Types	No.	Description	Recommended Types
1	Pump Discharge	Air/Vac	9	Decr. Downslope	No Valve Required
2	Incr. Downslope	Combination	10	Low Point	No Valve Required
3	Low Point	No Valve Required	11	Long Ascent	Air/Vac or Combination
4	Incr. Upslope	No Valve Required	12	Incr. Upslope	No Valve Required
5	Decr. Upslope	Air/Vac or Combination	13	Decr. Upslope	Air/Vac or Combination
6	Beg. Horiz.	Combination	14	High Point	Combination
7	Horizontal	Air-Rel or Combination	15	Long Descent	Air-Rel or Combination
8	End Horiz.	Combination	16	Decr. Upslope	Air/Vac or Combination

### AWWA sample profile for air valve location

These sample profiles are simplified rules-of-thumb meant for simple systems. The AWWA manual, in addition to the locations pointed out in the sample profile above, does mention location of valves at in-line isolating valves, before Venturi water meters, and for siphons. But not enough emphasis is given in these sample profiles to location for surge protection.

It is important to establish a smooth pipeline grade and not follow the terrain or an excessive number of air valves will be needed. The designer must balance the cost of air valve locations with the cost of additional excavation. The high points and grade changes that are less than 1 pipe diameter are typically ignored because the flow will flush accumulated air downstream.

**Note** - Combination valves can be used at any location instead of air release or air & vacuum valves to provide added air release capacity on the pipeline.

### AIR VALVE SIZING

Proper sizing of air valves is essential for effective, efficient, and safe air control. There is no standard accepted method to determine automatic air release flow requirements under pressure, since it is difficult to determine the amount of accumulated air in the system. Sometimes, a value of 2% of the operational water flow-rate is used, based on 2% solubility of air in water.

Kinetic, large orifice air discharge requirements are usually based on the pipeline fill-rate, and are equal to the designed pipe filling flow-rate. Smaller large orifice air valves are sometimes

used in sections along the pipeline, to throttle fill-rate, thus decreasing the danger of pressure surges at pipe filling.

Air intake requirements are usually considered the determining factor in air valve sizing. Most air valve manufacturers suggest the use of a pipe burst analysis using one of the common flow formulas, such as the Hazen-Williams Equation, the Darcy-Weisbach Equation, the Manning Equation, the Chezy Equation, or an equation derived from one of these. The analysis usually assumes a full diameter pipe burst resulting in a full diameter free water flow. In order to protect the pipe from collapse due to vacuum conditions, a large orifice air valve with an air intake capacity equal or greater than the above free water flow, is required.

### **Air / vacuum Valve Sizing**

For determining air intake requirement in valve sizing, the AWWA, in its M51 manual, suggests the use of an equation derived from the Chezy Equation:

$$Q = 0.0472 C \sqrt{SD^5}$$

Where:

- Q = flow-rate in scfm
- C = Chezy coefficient (110 for iron, 120 for concrete, 130 for steel, 190 for PVC)
- S = pipeline slope in feet per foot of length
- D = pipeline inside diameter in inches



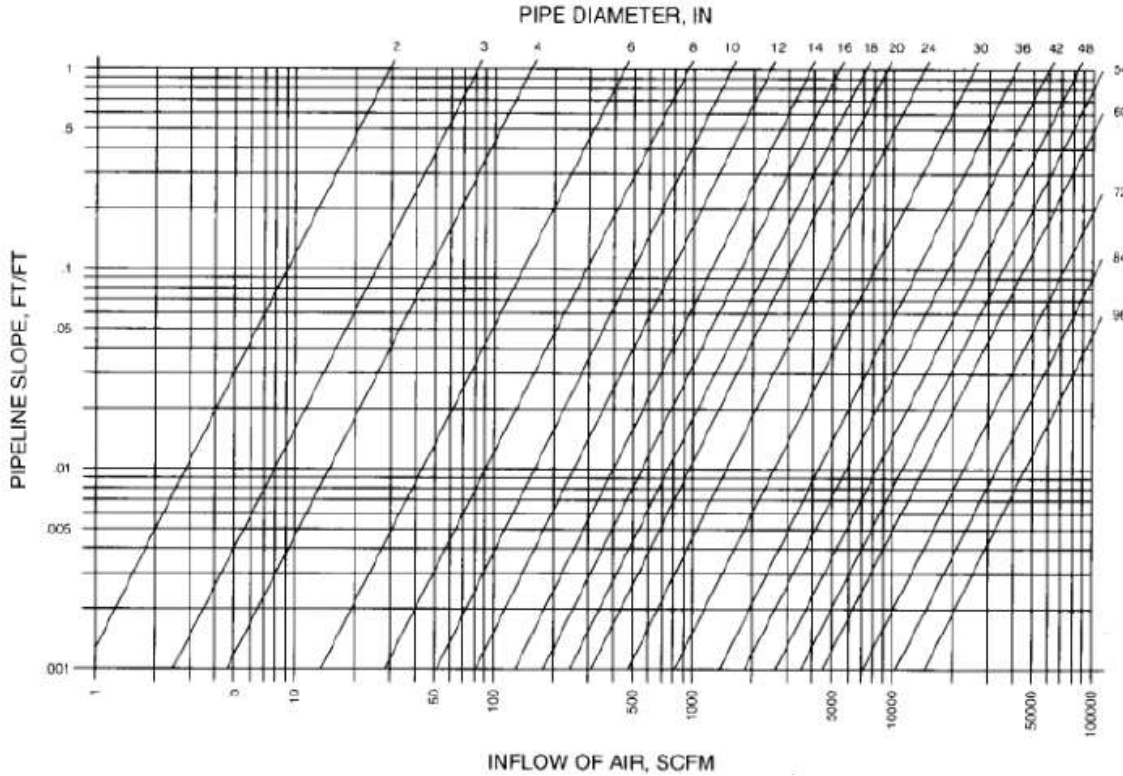

As can be seen from the equation, air flow-rate requirements, in this analysis, are determined from the pipe inside diameter and slope. The other factors are constant for the particular pipe material. At very steep runs, no matter what the elevation differences (Kh), air intake requirements can be very high, and sometimes unrealistic. For small elevation changes, for instance, there may not be enough time for the air valve to open, or substantial sub-atmospheric pressures may not be reached.

Air valve to be installed at this high point must release or re-enter an amount of air given by equation above. To economize in the size of valves selected, determine the maximum pressure differential which can be tolerated across the valve orifice consistent with the required flow of air already determined. To determine this maximum tolerable differential pressure, it is necessary to calculate if there is a risk of line collapse from vacuum. This condition is usually only present in thin-walled steel lines above 24”.

To calculate collapsing pressure for thin-walled-cylindrical pipe, use equation:

$$P = 12500000 \left( \frac{T}{D} \right)^3$$

Where

- P = Collapsing pressure (PSI)
- T = Thickness of pipe (inches)
- D = Diameter of pipe (inches)

Includes Safety Factor of 4

Some publications list a rule of thumb that suggests air & vacuum valves be 1 inch per 1-ft (0.3-m) of pipe diameter. This means a 4-ft (1.2-m) diameter line would have a 4-in (100-mm) diameter valve.

### **Air Release Valve Sizing**

The capacity of releasing air under line pressure through an air release valve can be estimated by using the air & vacuum valve formula, except P1 will equal the operating pressure in the line. The differential pressure (DP) is limited by sonic velocity to about  $0.47 * P1$ . The corresponding expansion factor (Y) is 0.71.

$$Q = 14.5 d^2 C (P+14.7)$$

Where:

- q = Air flow, SCFM
- d = Orifice diameter, inches
- P = Pipeline pressure, psig
- C = Discharge coefficient = .65 for air release orifice

It is difficult to determine in advance the amount of entrapped air which must be released from a given system. Based on water containing two percent air, the maximum flow rate can be used to compute a nominal venting capacity.

$$Q = q (0.13 \text{ cu-ft. /gal}) .02$$

Where:

- Q = Air flow, SCFM
- q = System flow rate, GPM

In most cases, the size of the air release valve is a judgment decision based on experience. The 2% air content can be varied depending on the potential for entrained air in the water source. The air release valve inlet connection should be as large as possible to maximize the exchange of air and water in the valve. A helpful chart based on industry experience with average installations is shown below.

MAX. PIPE SIZE	MAXIMUM PUMP CAPACITY GPM	SYSTEM PRESSURE – P.S.I.					
		1 to 50 *		1 to 150 *		1 to 300 *	
		ORIFICE SIZE	CAPACITY IN CFM	ORIFICE SIZE	CAPACITY IN CFM	ORIFICE SIZE	CAPACITY IN CFM
6	800	N/A	N/A	1/16	6	N/A	N/A
10	2,200	N/A	N/A	3/32	14	1/16	12
16	5,200	N/A	N/A	1/8	24	5/64	18
48	50,000	5/16	58	3/16	54	3/32	26
96	150,000	1/2	149	3/8	220	7/32	143

### Air Venting Options

The other options to vent air out of a liquid piping system include:

1. Degassing valve
2. Vacuum breaker
3. Pressure relief valve
4. Air separator

Each has its advantages and limitations.

**Degassing Valve** -- Designed for periodically venting trace amounts of gas as it occurs. Like an air release valve, this normally- open valve closes once liquid rises in the system. But unlike an air release valve, a degassing valve will automatically re-open whenever additional pockets of gas rise in the valve, even when the system is pressurized. Once the gas is expelled, the presence of liquid closes the valve. The venting orifice on this type of valve is substantially smaller than a typical air release valve, so it is not suitable for rapidly venting a

large volume of air. With that in mind, systems prone to continuous out-gassing will benefit from both an air release valve and a degassing valve.

It is important to note that a degassing valve will not "trap" or collect gas as it passes by the valve, so it must be installed on a lead at high points in a pipeline where gas would otherwise collect naturally. Even miniature degassing valves built into dosing pumps are only capable of expelling accumulated gas, not gas entrained in liquid. In many cases an additional degassing valve is required elsewhere in the system.

You may have noticed above that air release and degassing valves are generally "normally-open" designs, in other words, unless liquid is present, both allow air to flow into a piping system. With that in mind, it might seem that these valves could provide the function of a vacuum breaker. But air release and degassing valves are designed specifically to expel air, and are not as effective for drawing air into a system. For that purpose, a normally-closed valve is much better suited.

**Vacuum Breaker** -- There are many types of vacuum breakers. The most versatile and effective are normally-closed valves that allow air to flow in one direction only -- into a tank or pipeline. A vacuum breaker is most commonly used to prevent a tank from collapsing when liquid is pumped out or drained from the tank. But the key to this valve is the fact that it is normally-closed, and shuts automatically as soon as the tank returns to atmospheric pressure, preventing vapors or harmful liquids from flowing out of a tank.

Another popular application for the vacuum breaker is to prevent siphoning. When pumping to a pipeline below tank level, the flow of liquid often creates a vacuum in the pipeline when the pump is turned off, which results in suction and can siphon the tank. By installing a vacuum breaker in a section of pipeline above the tank level, the vacuum condition will cause the valve to open and create an air pocket. The air pocket will stop the flow of liquid, and because this section of pipe is now above the level of the supply tank, it will no longer siphon.

### **How an air release valve is different from pressure relief valve?**

When considering the function of an air release valve, some might assume that a pressure relief valve can fit the bill. Yes, a pressure relief valve will vent air at a pre-set pressure point, but it will also vent precious liquid -- a pressure relief valve cannot tell the difference. Furthermore, a relief valve won't vent accumulated air at pressures below the set point. Unlike

a pressure relief valve, an air release valve is open at atmospheric pressure, then closes automatically when liquid is present.

### **What is an air separator?**

An air separator removes the air from the circulating fluid in a closed loop piping system. It is essentially an expansion tank with a baffle arrangement. It works on two basic principles:

1. As fluid velocity decreases, air tends to separate from the water.
2. Air is lighter than water.

As the fluid flows through the vessel, the internal baffle “peels” off this air and directs it toward the top of the scoop. Also, as the fluid enters the vessel, it encounters an abrupt increase in cross-sectional area compared to the piping. This, of course, decreases the velocity. The decrease in velocity allows the air to further separate. The added height gives the air a place to migrate, as it seeks “higher ground.” The air separator is generally on the supply side of the boiler, the point of highest temperature, where the air solubility is lowest. The air separator is also on the suction side of the pump, where the system pressure is lowest.

### **Summary**

When air is allowed to accumulate in pressurized pipelines, efficiency is sacrificed and serious damage can occur. Removal of entrapped air is thus important to improve pipeline efficiency and help protect the pipe from adverse pressure conditions. Today the most common method of air control is use of air release valves that function by admitting large quantities of air when needed, and releasing air continuously in pressurized liquid conveyance systems.

There are other special purpose valves – each having its advantages and limitations. To summarize:

- Air Release Valves automatically vent a large volume of air out of a tank or piping system at start-up.
- Degassing Valves continuously vent trace amounts of air out of a tank or piping system.
- Vacuum Breakers automatically vent a large volume of air into a tank or piping system.

- Pressure relief valve vent air only at a pre-set pressure point and is primarily used as safety device for pipe and equipment protection.

It is not unusual for applications to require all these to help the system operate at peak efficiency. Depending on the complexity of the system and how prone it is to building up air/gas, some applications could require multiple usage for some or all of these valves.

**References:**

Information based on:

1. AWWA Manual of Water Supply Practices M51 Air-Release, Air & vacuum & Combination Air Valves
2. Manufacturers' published information