



**PDHonline Course M504 (4 PDH)**

---

# **An Introduction to Exterior Mechanical Utility Distribution**

*Instructor: J. Paul Guyer, P.E., R.A., Fellow ASCE, Fellow AEI*

**2020**

**PDH Online | PDH Center**

5272 Meadow Estates Drive  
Fairfax, VA 22030-6658  
Phone: 703-988-0088  
[www.PDHonline.com](http://www.PDHonline.com)

An Approved Continuing Education Provider

# **An Introduction to Exterior Mechanical Utility Distribution**

*J. Paul Guyer, P.E., R.A.*

## **CONTENTS**

- 1. DESIGN RESPONSIBILITIES FOR UNDERGROUND  
PRE-ENGINEERED HEAT DISTRIBUTION SYSTEMS**
- 2. DISTRIBUTION SITE LOCATION FACTORS**
- 3. SERVICE AND LOADS**
- 4: SPECIFIC PIPING DESIGN FACTORS**

(This publication is adapted from the *Unified Facilities Criteria* of the United States government which are in the public domain, are authorized for unlimited distribution, and are not copyrighted.)

(Some of the figures, tables and equations in this publication may at times be a little difficult to read, but they are the best available. **DO NOT PURCHASE THIS PUBLICATION IF THIS LIMITATION IS UNACCEPTABLE TO YOU.**)

**1. DESIGN RESPONSIBILITIES FOR UNDERGROUND PRE-ENGINEERED HEAT DISTRIBUTION SYSTEMS.** The project designer is responsible for accomplishing the following prior to project bidding:

- a) Define site conditions for underground water classification (A, B, C, or D), soil corrosiveness, soil pH if less than 5.0, and potential soil load bearing problems.
- b) Determine the general layout and essential characteristics of the system such as system media, maximum operating temperature and pressure, location and design of manholes, and branch runouts. The interface detail of the system at manhole walls shall be provided by the system supplier.
- c) Design special elements of the system as required.
- d) Calculate the maximum heat loss per lineal foot of the conduit.

**1.1 DESIGN BY PROJECT DESIGNER.** The project designer shall design on project drawings the exterior steam and condensate piping systems aboveground, the manholes, piping within manholes, and piping not in approved conduit systems. The project designer shall establish the system design parameters of the entire underground piping system, such as site classification, general layout, essential characteristics of the system, and specially designed elements of the system. The project designer is responsible for sizing the pipe, establishing the piping elevations, identifying the piping right-of-way, obstructions and utilities (plan and profile) within 25 feet (7.62 m) of the center line of the right-of-way, and every area within 25 feet of the center line that must be avoided; for example, paved areas and buildings. The project designer is also responsible for the location and sizing of manholes, the design of concrete manholes and the piping and equipment layout of manholes including valves, fittings, traps, expansion joints (when required), and manhole drains.

**1.2 DESIGN BY SYSTEM SUPPLIER.** The construction Contractor shall design and provide buried factory-prefabricated preinsulated piping in a conduit or pre-engineered insulated piping

system which owner has approved. It is intended that the supplier of an approved system provide the details of design for his system in accordance with the owner's requirements. The preapproved design will address expansion loops, bends, offsets, concrete pipe anchors outside of manholes, interface with each manhole, and the watershed to aboveground piping. When prefabricated steel manholes are indicated, the system supplier is responsible for the structural design of the manhole and the manufacture of the complete manhole, including installation of valves, fittings, and other equipment as specified herein and indicated on the project drawings. The Contractor is responsible for the design, fabrication, and installation of the underground piping system within the system design parameters established by the project designer.

**2. DISTRIBUTION SITE LOCATION FACTORS.** Fluid distribution site locations should be according to the following:

**2.1 LOCATION FACTORS.** For location factors for each system, refer to Table 1.

**2.2 SUBSURFACE EXPLORATIONS.** When a concrete trench or a buried steam or hot water system is specified, make a thorough investigation of ground and water conditions shall be made. Employ a soils engineer familiar with ground water conditions at the site to establish the classification. In the absence of existing definitive information on soil types and ground water conditions, make a detailed site classification survey. Upon completion of the survey, classify each exploration point as A, B, C, or D on the basis of the criteria presented in Tables 2 and 3. The worst ground water condition encountered between adjacent manholes determines the class of the system to be installed between adjacent manholes. Conduct this survey within the guidelines specified.

**2.2.1 TIMING OF SURVEY.** Conduct the survey after the general layout of the system has been determined.

**2.2.2 TIME OF YEAR.** Make the survey at a time of year when the highest water table is expected to exist, if possible. If this is not possible, correct water table measurements on the basis of professional judgment, to indicate conditions likely to exist at the time of year when the water table is at its highest point.

**2.2.3 EXPLORATION CONSIDERATIONS.** As a minimum, collect information on ground water conditions, soil types, terrain, and precipitation rates and irrigation practices in the area of the system. Information on terrain and precipitation rates and irrigation practices may be obtained from available records at the installation.

**2.2.4 TEST EXPLORATIONS.** Make test explorations (borings or test pits) at least every 100 feet (30.5 m) along the line of a proposed system. If changes in stratification are noted, decrease the boring spacings so an accurate horizontal soil profile may be obtained.

ITEM	DETERMINE THE FOLLOWING
Load Centers	Maximum demand load of system. (See criteria in Table 1 and ascertain requirements of all facilities.) Distance from generating plant. Basements or crawl spaces under buildings available for piping. Location of entry of system to load center structure. Location or need of meters for billing purposes. Future expansion.
Route	Existing piers, tunnels or trenches available for system. Aboveground obstructions, such as rivers, lakes, roads, railroads, structures, etc. Belowground obstructions, such as tunnels, trenches, piping, rock, storage tanks, etc. Location of expansion loops, joints and manholes. Master Plan.
Site	For above and underground systems: Ground contours along route. For underground systems: Borings every 100 feet along route - longer for larger projects. Absorption test Resistivity test Stability of soil Water table survey made at time of highest levels if possible, or modify by judgement based on local data. Maximum, normal, and minimum groundwater levels. Frost level.
Coordination	Location of distribution line drainage and venting. Installation of other related distribution systems and manholes. Interference with electric distribution lines and manholes. Interference with water supply and fire extinguishing systems. Interference with sanitary and storm sewers and manholes. Interface with communications systems. Interference with ground drainage lines, catch basins, and manholes. Interference with fuel distribution piping systems. Interface with other gas supplies such as argon, nitrogen and carbon dioxide used in industrial process work. Excavation and backfill. Landscaping.
Cooperation	Local rules and regulations (permits, tests approvals, etc.).
Hazards	Excavation of soil and rock and of landfill. Piping material. Piping insulation or covering. Pipe conduit. Construction of manholes. Construction of expansion loops and field joints.
Local labor	Availability and costs.
Local material	Availability and costs.

Table 1

Location factors for each distribution system

FIELD IDENTIFICATION PROCEDURES (Excluding particles larger than 3 inches and bearing frictions on estimated weights)		GROUP SYMBOLS	TYPICAL NAMES	PERMEABILITY WHEN COMPACTED
COURSE GRAINED SOILS More than half of material is smaller than No. 200 sieve size (The No. 200 sieve size is about the smallest particle visible to the naked eye)	FINE GRAINED SOILS Highly organic soils Readily identified by color, odor, spongy feel and frequently by fibrous texture.			
GRAVELS More than half of coarse fraction is larger than No. 4 sieve size. (For visual classifications, the 1/4" size may be used as equivalent to the No. 4 sieve size.)	CLEAN GRAVELS (Larger or no fines)	GW	Well graded gravels, gravel-sand mixtures, little or no fines.	PerVIOUS
	GRAVELS WITH FINES (Appreciable amount of fines)	GP	Poorly graded gravels, gravel-sand mixtures, little or no fines.	Vary PerVIOUS
	CLEAN SANDS (Little or no fines)	GM	Silty gravels, poorly graded gravel-sand mixtures.	SemiPerVIOUS to ImpervIOUS
	SANDS WITH FINES (Appreciable amount of fines)	GC	Clayey gravels, poorly graded gravel-sand mixtures.	ImpervIOUS
	GRAVELS More than half of coarse fraction is smaller than No. 4 sieve size (For visual classifications, the 1/4" size may be used as equivalent to the No. 4 sieve size.)	SW	Well graded sands, gravelly sands; little or no fines.	PerVIOUS
	SANDS WITH FINES (Appreciable amount of fines)	SP	Poorly graded sands, gravelly sands, little or no fines.	PerVIOUS
	CLEAN SANDS (Little or no fines)	SM	Silty sands, poorly graded sand-silt mixtures	SemiPerVIOUS to ImpervIOUS
	SANDS WITH FINES (Appreciable amount of fines)	SC	Clayey sands, poorly graded sand-clay mixtures	ImpervIOUS
IDENTIFICATION PROCEDURES ON FRACTION SMALLER THAN No. 40 SIEVE SIZE				
SILTS AND CLAYS Liquid limit less than 50	DRY STRENGTH CHARACTERISTICS) None to slight	DILATANCY REACTION TO SHAKING) Quick to slow	TOUGHNESS (CONSISTENCY NEAR PLASTIC LIMIT) None	ML
				CL
SILTS AND CLAYS Liquid limit greater than 50	DRY STRENGTH CHARACTERISTICS) Medium to high	DILATANCY REACTION TO SHAKING) None to very slow	TOUGHNESS (CONSISTENCY NEAR PLASTIC LIMIT) Medium	OL
				MH
SILTS AND CLAYS Liquid limit greater than 50	DRY STRENGTH CHARACTERISTICS) High to very high	DILATANCY REACTION TO SHAKING) None	TOUGHNESS (CONSISTENCY NEAR PLASTIC LIMIT) High	OH
				OHI
HIGHLY ORGANIC SOILS Readily identified by color, odor, spongy feel and frequently by fibrous texture.				PT

Table 2  
Soil classification

Site Class	General Conditions Required for such Classification	Conditions Found During Site Classification Survey that are Indicative of the Class			
		Relative to Water Table Level	Soil Types	Terrain	Precipitation Rates or Irrigation Practices in Area
A-Severe	Water table frequently above bottom of the system	Groundwater within 1 ft of bottom of system	Any	Any	Any
	Water table occasionally above bottom of the system and surface water accumulates and remains for long periods of soil surrounding the system	Groundwater within 1 ft of bottom of system	GC, SC, CL, CH, OH	Any	Any
B-Bad	Water table occasionally above bottom of the system and surface water accumulates and remains either for short periods in soil surrounding the system	Groundwater within 5 ft of bottom of system	GW, GP, SW, SP	Any	Any
	Water table never above the bottom of the system, but surface water accumulates and remains for long periods in soil surrounding the system	No groundwater encountered	GM, SM, ML, OL, MH	Any	Equivalent to 3 in. or more in any one month or 20 in. or more in one year
C-Moderate	Water table never above the bottom of the system, but surface water accumulates and remains for short periods in soil surrounding the system	No ground water encountered	GC, SC, CL, CH, OH	Any	Equivalent to 3 in. or more in any one month or 20 in. or more in one year
	Water table never above the bottom of the system and surface water does not accumulate and remain in soil surrounding the system	No groundwater encountered	GM, SM, ML, OL, MH	Any	Equivalent to less than 3 in. in any one month and to less than 20 in. in one year
D-Mild	Water table never above the bottom of the system and surface water does not accumulate and remain in soil surrounding the system	No groundwater encountered	GW, GP, SW, SP	Any	Any
			GM, SM, ML, OL, MH	Any except low areas	Equivalent to less than 3 in. in any one month and to less than 20 in. in one year

Table 3  
Soil classification criteria



**2.2.5 DEPTH OF EXPLORATION.** Extend all explorations 5 ft (1.53 m) below the expected elevation of the concrete trench invert or the depth of the preengineered system to determine ground water conditions.

**2.2.6 SPECIAL GROUND CONSIDERATIONS.** Give particular attention to the following conditions:

- a) The possibility that the ground below a backfilled piping system may not be able to absorb runoff that has seeped into it.
- b) Areas where ponding may occur, either along a sloping surface or in low flat areas.
- c) The permeability of the ground below the system.

**2.2.7 PERMEABILITY TESTS.** Perform field permeability tests as follows:

- a) Space field permeability tests (percolation) along the line of a trench at intervals of approximately 100 feet (30.5 m). When available information indicates uniform subsurface conditions, longer intervals may be allowed for larger projects.
- b) Dig holes approximately 1 foot<sup>2</sup> (0.093 m<sup>2</sup>) to a depth of 2 feet (620 mm) below the approximate bottom of a trench.
- c) Fill each hole with water to the bottom elevation of the planned trench.
- d) After the water has completely seeped away, immediately refill each hole with water to the same depth.
- e) If it requires 20 minutes or less for the water to drop 2 inches (51 mm), consider the soil dry; otherwise, consider it as saturated at times.

**2.2.8 TEST RESULTS.** Use test results as follows:

- a) If the soil is saturated, no further tests are required. Class A underground conduit systems for wet soils must be used.
  
- b) If the soil is dry, as defined above, deepen permeability test holes an additional 3 feet (920 mm) to determine if the water table is within 5 feet (1.53 m) of the trench bottom.

**2.2.9 SOIL RESISTIVITY.** Considerations for soil resistivity are as follows:

- a) Take soil resistivity readings along the conduit line (in accordance with Table 1).
  
- b) A cathodic protection system is required to protect metallic piping systems and manholes. This applies to all sites where soil resistivity is less than 30,000 ohms per centimeter (ohm-cm), where stray direct currents can be detected underground or where underground corrosion, due to local soil conditions, has been found to be severe.

**2.2.10 SOIL CORROSIVENESS CLASSIFICATION.** Have an experienced corrosion engineer make the classification based on a field survey of the site carried out in accordance with recognized guidelines for conducting such surveys. Classify the soil at the site as corrosive or noncorrosive on the basis of the following criteria:

- a) Corrosive: The soil resistivity is less than 30,000 ohms-centimeter (ohm-cm) or stray direct currents can be detected underground.
  
- b) Noncorrosive: The soil resistivity is 30,000 ohm-cm or greater and no stray direct currents can be detected underground.

**2.2.11 SOIL STABILITY.** During the above survey, observe and note the soil stability.. Note areas of unstable soil on the site plans depicting the distribution route.

**2.2.12 SOIL LOAD-BEARING CAPACITY.** As a part of the project designer's survey, have an experienced soils engineer investigate the load-bearing qualities of the soil in which the system will be installed. Identify the location and nature of potential soils problems. Depending on the nature of the problem, the designer may choose to reroute the line, use a combination of concrete shallow trench, direct buried, or aboveground low-profile systems, or elect to over-excavate and replace with nonexpensive fill.

**2.3 SITE CLASSIFICATION.** Base selection of the conduit system type on the underground water conditions at the project site as defined in Tables 1, 2, and 3 for Class A, B, C, or D application corresponding to underground water conditions ranging from severe to mild, respectively.

**2.3.1 CLASS A, SEVERE.** The water table is expected to be frequently above the bottom of the system or the water table is expected to be occasionally above the bottom of the system and surface water is expected to accumulate and remain for long periods in the soil surrounding the system.

**2.3.2 CLASS B, BAD.** The water table is expected to be occasionally above the bottom of the system and surface water is expected to accumulate and remain for short periods (or not at all) in the soil surrounding the system or the water table is expected never to be above the bottom of the system but surface water is expected to accumulate and remain for long periods in the soil surrounding the system.

**2.3.3 CLASS C, MODERATE.** The water table is expected to never be above the bottom of the system, but surface water is expected to accumulate and remain for short periods in the soil surrounding the system.

**2.3.4 CLASS D, MILD.** The water table is expected never to be above the bottom of the system and surface water is not expected to accumulate or remain in the soil surrounding the system.

**2.4 ANALYZING SITE CLASSIFICATION FOR APPLICATION OF PRE-ENGINEERED UNDERGROUND SYSTEM.** No system may be installed without prior approval of the owner. A system approved for higher classification is acceptable for use in lower classifications. For example, Class A is acceptable for Classes B, C, and D, etc.

## **2.5 ANALYZING SITE CLASSIFICATION FOR APPLICATION OF SHALLOW CONCRETE TRENCH SYSTEM**

### **2.5.1 SOILS**

**2.5.1.1 FINE GRAINED SOILS (IMPERVIOUS).** The highest ground water level evident during the wettest period of the year should be a minimum of 1 foot (305 mm) below the lowest point of water entry into the concrete shallow trench system. The lowest point of entry is defined as the joint between the concrete trench wall and concrete trench bottom. The concrete trench bottom will be continuous with no openings. The above condition will ensure that constructability of the concrete shallow trench is practical and that potential infiltration of water into the shallow trench will be negligible. Open drainage ways, swales, or swampy/boggy areas will preclude use of a concrete shallow trench system because of ground water level guidance in Table 2. The concrete shallow trench system must be rerouted or regraded to bring the concrete trench out of the unsuitable conditions. Have the geotechnical engineer who performed the detailed site classification survey provide regrading instructions. The designer will ensure that the fill will remain stable and will not be subject to future wash-outs. If the specific site conditions are such that these alternatives are not viable, consider aboveground low profile or a direct buried system of the prefabricated or preengineered type in accordance with the owner's requirements for these areas.

**2.5.1.2 COARSE GRAINED SOILS (SEMIPERVIOUS/PERVIOUS).** The ground water level during the wettest period of the year should be at least 1 foot (305 mm) below the lowest point of water entry into the concrete shallow trench system.

#### **2.5.1.2.1 WATER TABLE LOCATED 1 TO 2 FEET (305 TO 610 MM) BELOW**

**LOWEST POINT OF WATER ENTRY.** The criteria specified applies.

**2.5.1.2.2 WATER TABLE LOCATED 2 OR MORE FEET BELOW LOWEST POINT OF WATER ENTRY:**

Concrete shallow trench systems with noncontinuous bottom (tunnel constructed of noncontinuous concrete bottom with openings provided in bottom at intervals of 4 feet (1220 mm) or more to permit drainage into the semipervious/pervious soils) may be used. Special considerations are required when the concrete shallow trench would traverse open drainage ways or swales where the water table would be less than 2 feet (610 mm) below the concrete trench bottom. The designer may elect to reroute the system, place fill to bring the system out of the unsuitable conditions, or provide a continuous bottom trench floor for this area of the site.

**2.5.1.3 SWELLING SOILS** (material with high swell potential): If the specific site conditions are such that these alternatives are not viable, consider aboveground low profile or a direct buried system of the prefabricated or preengineered type in accordance with the owner's criteria for those areas. Design the concrete shallow trench system in materials having high swell potential. Soils having a liquid limit (LL) greater than 50 and a plasticity index (PI) greater than 25 require testing (consolidation swell) to determine the swell characteristics. When the results of the swell test indicate high swell potential, special considerations such as over excavation (width and depth) and replacement with nonexpansive fill, under-trench drainage system or other methods of minimizing differential heave will be provided. The design of special features such as described above will be in accordance with instructions provided by the geotechnical engineer who performed the detailed site classification survey. Design of joint spacing and joint details to accommodate movements will also be provided when required.

**2.5.2 SETTLEMENT OF TRENCHES.** Generally, settlement of concrete trenches will not be a problem since the unit load of the shallow trench system will be similar to the existing unit overburden load. Backfill adjacent to the concrete trench must be thoroughly compacted to prevent settlement which would create ponding. Positive slopes away from the concrete trench are desirable. Special care of backfill and compaction is required where the system crosses

existing streets to preclude settlement and cracking of the roadway adjacent to the trench from repeated traffic loads.

**2.5.3 UNDER-TRENCH DRAINAGE SYSTEMS.** Use concrete trench subdrain systems as required. When subsurface conditions are of differing soil types, (fine grained and coarse grained) and those differing soil conditions will cause blocked drainage either horizontally or vertically adjacent to the concrete trench, provide subdrains to ensure drainage to prevent ponding or entrapment of water adjacent to the shallow trench system. Base the design of the subdrain system on the instructions provided by the geotechnical engineer who performed the detailed site classification survey and classified each exploration point. Soils of low permeability and high moisture content (lean and fat clays (CL-CH)) shall not require under-drains when the shallow trench system is designed to accommodate all anticipated inflow with systems or equipment such as direct connections to storm sewers or the use of dual sump pumps. Connect drainage system sump pump discharge pipes to storm sewer system where feasible. If not feasible, provide discharge to splash blocks on grade. When discharging to grade install the pump discharge line without a check valve to allow complete drainage of the discharge pipe to prevent freezing. Do not use under-trench drainage to alter ground water level to meet requirements of Table 2.

**2.6 REINFORCED THERMOSETTING RESIN PLASTIC (RTRP) PIPE.** RTRP pipe is normally supplied, when used for condensate systems. This pipe is suitable for service pressures up to 150 psig (1034 kPa) and temperatures up to 200 degrees F (93 degrees C). Above 200 degrees F (93 degrees C) the pressure rating drops off rapidly. At 250 degrees F (121 degrees C) the pressure rating is 125 psig (861.3 kPa) and drops to 45 psig (310.1 kPa) at 270 degrees F (132 degrees C). These ratings are for hot water. Live steam cannot be tolerated, although RTRP pipe may be used for vented gravity condensate piping as well as for pumped condensate piping. RTRP pipe is acceptable at Class B sites. It is recommended for Class A sites, as permitted by the owner, due to its low cost and long service life. Procure and install RTRP condensate piping in accordance with the owner's requirements. Take special care in the design of steam drip connections to protect the RTRP piping from live steam from failed traps.

Insulate condensate piping only when a life-cycle cost analysis indicates a payback in energy savings, or where needed for personnel protection (manholes, for example).

**3. SERVICE AND LOADS.** Determine from the services, such as steam, high temperature water, hot water, chilled water, compressed air, fuel gas and others, required for each load center or building, the load demands for each service, and the capacity of a source or central plant for each service.

**3.1 ALTERNATE ROUTES.** Refer to the appropriate master plan and consider system routing and size to accommodate future construction.

**3.2 PRESSURE DROP.** From the total allowable pressure drop and ultimate length of a line, determine the pressure drop per 100 feet (30.5 m). Note the maximum flow between each load center and size the different pipeline sections accordingly.

**3.3 OBSTACLES.** From a field survey, note all obstacles for each route.

**3.4 FUTURE LOADS.** Refer to master plan and consider system routing to accommodate future construction.

**3.5 DISTRIBUTION CIRCUITS.** Select a circuit which is economical, easy to operate, balance and control, and is suitable for a particular project terrain. Note that types easiest to balance and control are those where pressure and temperature differences are fairly constant between equipment supply and return branches.

**3.6 ROUTE TYPES.** Run distribution piping through buildings, aboveground, or underground and below piers.

**3.6.1 THROUGH BUILDINGS.** Select the route considered technically and economically best justified; make full use of building piers, underpiling spaces, basements, crawl spaces, and attics, including connecting corridors between buildings, existing tunnels and concrete trenches. However, high-pressure fuel gas, steam, and HTW piping inside buildings should be routed to comply with federal and local fire and life safety codes. Gas piping shall comply with ANSI B31.8, Gas Transmission and Distribution Piping Systems, and NFPA 54, National Fuel



Gas Code. Steam, condensate and compressed air lines shall comply with ANSI B31.1, Power Piping.

**3.6.2 EXTERIOR STEAM DISTRIBUTION.** Use owner's requirements for all steam distribution piping exposed to the weather, on building exteriors, aboveground piping supports, piers (pedestals), poles, and for all steam piping on piers and under piers, in tunnels and in manholes. Use owner's requirements for piping in trenches. Use owner's requirements for buried steam piping.

**3.6.3 ABOVEGROUND OVERHEAD PIPING.** Locate piping as low as 1 foot (305 mm) or as high as 22 feet (6.7 m) above the ground surface. A 16-foot (4.9 m) clearance is required for automobile and truck traffic, and a 22-foot (6.7 m) clearance for railroad cars.

**3.6.4 BURIED PIPING.** For buried piping routes, the following criteria apply:

**3.6.4.1 COMPRESSED AIR AND GAS PIPING.** Compressed air and gas piping generally require no insulation, but they should be shop coated, wrapped, tested, and handled in accordance with owner's requirements. Provide for testing of coverings by electrical flow detectors (spark test).

**3.6.4.2 MINIMUM COVER.** Protect all buried piping and conduits by laying them under a minimum cover of 24 inches (610 mm). However, protect buried piping under railroads, roads, streets, or highways or due to changes in ground contours against possible external damage due to the superimposed car or truck traffic. Lay pipes below the frost line. Casings may be needed where there is no frost.

**3.6.4.3 OTHER HAZARDS.** When piping must be laid where it will be subjected to hazards such as earthquakes, washouts, floods, unstable soils, landslides, dredging of water bottoms and other categorically similar conditions, protect it by increasing pipe wall thickness, constructing intermediate supports or anchors, erosion prevention, covering pipes with concrete, adding seismic restraints for above-grade piping or other reasonable protection.

**3.6.4.4 MANHOLES.** Select manhole locations in accordance with the following. Details of piping and design of manholes are the responsibility of the project designer. Design manholes to provide adequate space for maintenance, proper venting and quick egress. Manholes are required where vertical offsets in steam piping are required to conform to grading requirements. Manholes accommodate the required steam main drip traps and any block valves needed. Manholes are usually provided at all major branch line connections and at drip traps on compressed air lines.

**3.6.4.5 TUNNELS.** Construct tunnels for underground routes with a walkway minimum height of 76 inches (1.93 m) and clear width of 36 inches (920 mm), with piping stacked vertically on one side and enlarged zones for crossovers and takeoffs. Label all pipes and conduit. Provide enough room to reach all flange bolts, to operate tools, and to operate or to replace any component. Run a drainage trench along one wall to a point of disposal such as a storm sewer or a sump pit, with an automatic drainage pump driven by an electric motor or steam jet. Install all electrical systems in rigid metal conduit. Identify and separate by voltage class. Tunnels shall be well lighted and ventilated. Use moisture resistant electrical fixtures. Tunnels may be built of reinforced concrete, brick, or other suitable structural materials, and shall be membrane waterproofed.

**3.6.5 CONDENSATE RETURN COST.** Refer to owner's requirements.

**3.6.6 CHOICE OF ROUTE.** Except in congested and vulnerable areas, choose aboveground routes for heat distribution systems. Otherwise, adapt site conditions to comparative advantages of going above or underground as stated below:

Aboveground	Underground
Lower first cost	Less heat loss on hot lines Less vulnerable target
Less maintenance	Less obstruction to aboveground traffic
Easy detection of failure	Less unsightly
Higher continuous operating efficiency	Freeze protected when buried
Longer life	Less heat gain in chilled and condenser water piping

**3.6.7 PIPING LAYOUTS.** The project designer is responsible for determining location of expansion bends, loops and joints, anchors, takeoffs, isolation valves, and drip points. The project designer is also responsible for locating all manholes, takeoffs, isolation valves, and drip points. The system designer determines the initial location of anchors, expansion bends, loops and joints; the system supplier determines final location and design of these features to fit actual field conditions. Plan and position piping layouts as follows:

- a) Determine what lines between the same points should be parallel to each other (such as supply and return) or be separated (such as steam from chilled water). The minimum clearance between pipe conduits in the same trench shall be 6 inches (150 mm).
  
- b) Determine locations of expansion bends or loops, anchors, takeoffs, and drip points. In non-pre-engineered/prefabricated heat distribution systems, the project designer is responsible for determining location of expansion bends, loops and joints; anchors; takeoffs; isolation valves; and drip points. In pre-engineered/prefabricated heat distribution systems, the project designer is responsible for locating all manholes, takeoffs, isolation valves and drip points. Initial location of anchors, expansion bends, loops and joints shall be by the system designer. The system designer determines the initial location of anchors, expansion bends, loops and joints;

the system supplier determines final location and design of these features to fit actual field conditions.

c) Lay out piping on a scaled contour map of the site and on a profile drawing along the route, locating all obstructions and interferences, such as streams, roads, railroads, buried tunnels, concrete trenches, drainage piping, sewers, water piping, electrical conduits, and other service piping, within 25 (7.6 m) feet of the center line of the right-of-way and identify areas within 25 feet of the center line that must be avoided. If sufficient right-of-way to accommodate pipe expansion cannot be identified and expansion joints are required, they must be specified and located with installation details noted on the drawings.

d) Provide a log of soil conditions along the piping right-of-way which gives, as a minimum, soil type, soil resistivity and pH, bearing strength and unstable conditions, and indicate corrective work required.

e) Provide details at building entries on the project drawings to show pipe elevation, floor elevation, building wall construction, and existing equipment.

**3.6.8 UNDERGROUND.** Use only approved and certified conduit systems for steam, condensate and HTW, and procure and install in accordance with the requirements of the owner. Concrete shallow trench systems may be used only if the soil characteristics set forth by the owner are met.

**3.7 INSULATION.** Evaluate insulation for all piping systems with the potential for significant thermal losses. These include steam, condensate, HTW, MTW, LTW, and CHW piping.

**3.8 MISCELLANEOUS CRITERIA.** Anchor or guy exterior distribution systems to withstand the wind velocity specified for design of structures.

## **4. SPECIFIC PIPING DESIGN FACTORS**

### **4.1 FLUID CHARACTERISTICS**

**4.1.1 STEAM.** Refer to Keenan and Keyes, Thermodynamic Properties of Steam.

**4.1.2 CONDENSATE.** For the economics of returning condensate, use the American Society of Heating, Refrigerating, and Air Conditioning Engineers (ASHRAE) 1985 Handbook - Fundamentals and ASHRAE 1987 Handbook - HVAC Systems and Applications.

**4.1.3 HIGH TEMPERATURE WATER (HTW), MEDIUM TEMPERATURE WATER (MTW), AND LOW TEMPERATURE HOT WATER (LTW).** Use ASHRAE Handbook - Fundamentals and ASHRAE Handbook - HVAC Systems and Applications.

**4.1.4 COMPRESSED AIR.** For data on compressed air, refer to owner requirements.

**4.1.5 NATURAL GAS.** Refer to NFPA 54.

## **4.2 DISTRIBUTION SYSTEM PIPING**

**4.2.1 EQUIVALENT LENGTHS OF PIPING.** To the straight lengths of pipe along a pipeline route, add equivalent lengths for valves and fittings as indicated in Table 4.

**4.2.2 SIZING OF DISTRIBUTION PIPING.** Size distribution piping as follows:

**4.2.2.1 MINIMUM PIPE SIZE.** Use minimum of 2-inch (51 mm) pipe which requires extra strong piping for direct buried piping with threaded end connections sized for piping in shallow trench system with all joints welded. Smaller pipe sizes and threaded joints are allowable in valve manholes.

**4.2.2.2 STEAM PIPING.** The project designer shall specify the design temperatures and pressures. The approved systems are suitable for temperatures to 450 degrees F (232 degrees C). If higher temperature systems are required, review manufacturers' approved brochures to

determine the exceptions to the brochures to be made in the project specification relative to pipe material, pipe expansion, and valve classification. Design considerations are as follows:

ITEM	DESCRIPTION OF PRODUCT	EQUIVALENT LENGTH IN PIPE LENGTH/DIAMETER
<b>Valves:</b>		
Conventional globe	With no obstruction in flat, bevel or plug type seat.	Fully open 340
	With wing or pin guided disc.	Fully open 450
Y-pattern globe	With stem 60 degrees from run of pipe line.	Fully open 175
	With stem 45 degrees from run of pipe line.	Fully open 145
Conventional angle	With no obstruction in flat, bevel or plug type seat.	Fully open 145
	With wing or pin guided disc.	Fully open 200
Conventional wedge, disc, plug or gate.		Fully open 13
		Three-quarters open 35
		One-half open 160
Pulp stock gate		One-quarter open 900
		Fully open 17
		Three-quarters open 260
		One-half open 1,200
		One-quarter open 3 2/3
Conduit pipe line gate		Fully open 20
Butterfly 6-inch and larger		Fully open 135
Conventional swing check		0.5 3/4 - Fully open 50
Clearway swing check		0.5 3/4 - Fully open 50
Globe lift check or stop-check		2.0 3/4 - Fully open
Angle lift check or stop-check		2.0 3/4 - Fully open
Foot valves		0.3 3/4 - Fully open 420
	With strainer and poppet lift-type disc.	0.4 3/4 - Fully open 75
in-line ball check	2.5 vertical and leather-hinged disc.	3 - fully open 150
Straight through cocks	Rectangular plug port area equal to 100% of pipe area.	Fully open 18
Three-way cocks	Rectangular plug port area equal to 80% of pipe area (fully open).	Flow straight through 44
		Flow through branch 140
<b>Fittings:</b>		
90 degrees standard elbow		30
45 degrees standard elbow		16
90 degrees long radius elbow		20
90 degrees street elbow		50
45 degrees street elbow		26
Square corner elbow		57
Standard tee	With flow through run.	20
	With flow through branch.	60
Close pattern return bend		50

1/ Legitimate for all flow conditions except in laminar flow range where Reynolds number is less than 1000.  
 2/ Exact equivalent length is equal to the length between flange faces of welding ends.  
 3/ Minimum calculated pressure drop in psi across valve to provide sufficient flow to lift disc fully.  
 Note: For additional data refer to DM-3.05.

Table 4  
 Representative equivalent length in pipe diameter/ratio (L/D)  
 for various valves and fittings

**a) STEAM FLOW CHARTS.** For pressures of 30 psig (206.7 kPa), 50 psig (344.5 kPa), 100 psig (689.4 kPa), and 150 psig (1033.5 kPa), see Figures 1 through 4. These charts show weight-rate pressure drop and velocities of saturated steam in Schedule 40 steel pipe. By selecting all pipe sizes on an optimum pressure drop, the total pressure drop of a pipeline may be estimated from an equivalent length, irrespective of pipe size. The charts are based on the rational flow formula (Darcy) shown below. For higher pressures, refer to Piping Handbook, by Crocker and King.

**b) RATIONAL FLOW CHARTS.** The simplified rational flow formula (Darcy) is used for compressible fluids for all pressures:

$$P_{100} = W^2 (0.000336 f) (v/d^5) = C_1 \times C_2 \times v \quad (\text{eq 1})$$

Where:

$P_{100}$  = pressure drop per 100 feet of equivalent length of pipe (psi)

$C_1 = W^2 10^9$  (for values, see figure 5)

$C_2 = 336000 f/d^5$  (for values, refer to table 5)

$W$  = rate of flow, pounds per hour (pph) (0.454 Kg/h)

$f$  = friction factor

$d$  = inside diameter of pipe (in)

$v$  = specific volume of fluid (ft<sup>3</sup> per lb) at average pressure

**c) VELOCITIES.** (refer to table 6)

$$v = 3.06 W/d^2 \quad (\text{eq 2})$$

Where:

$v$  = velocity of flow (fpm)

$W$  = density (pcf)



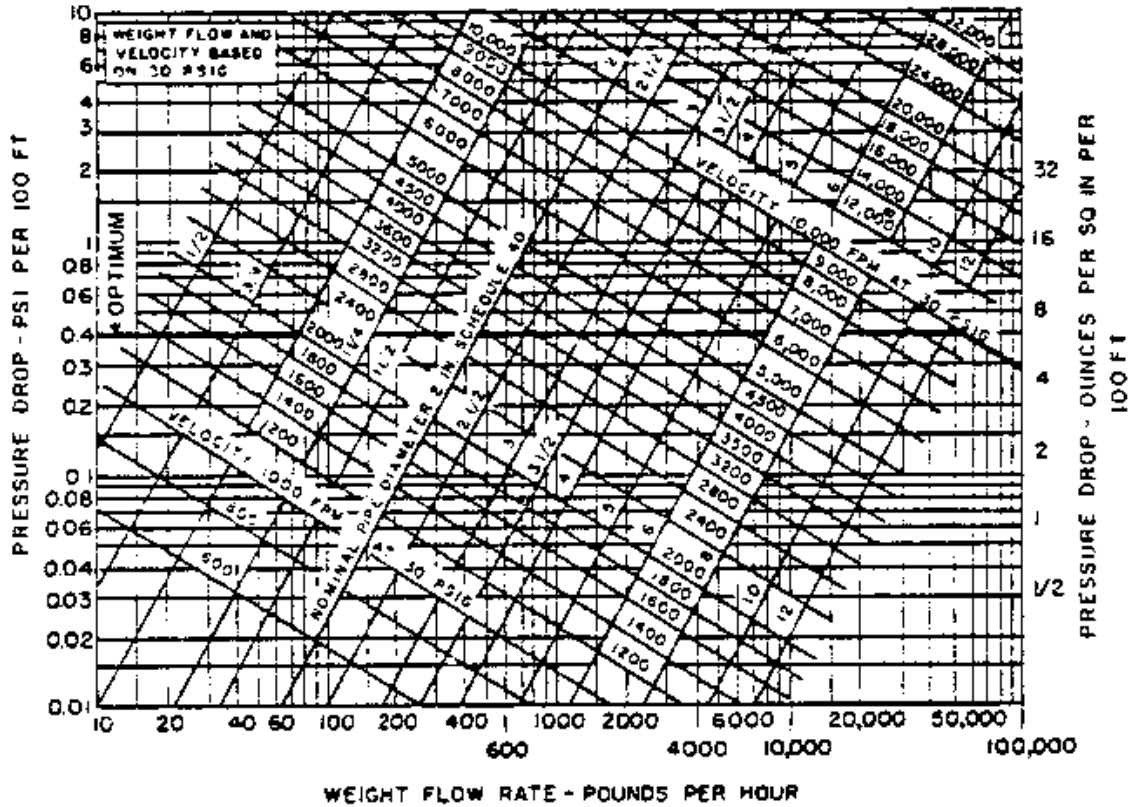

(MAY BE USED FOR STEAM PRESSURES FROM 23 TO 37 PSIG WITH AN ERROR NOT EXCEEDING 8 PERCENT) BASED ON MOODY FRICTION FACTOR WHERE FLOW OF CONDENSATE DOES NOT INHIBIT THE FLOW OF STEAM.

Table 1  
Chart for weight-flow rate and velocity of steam (30 psig) (206.7 kPa)

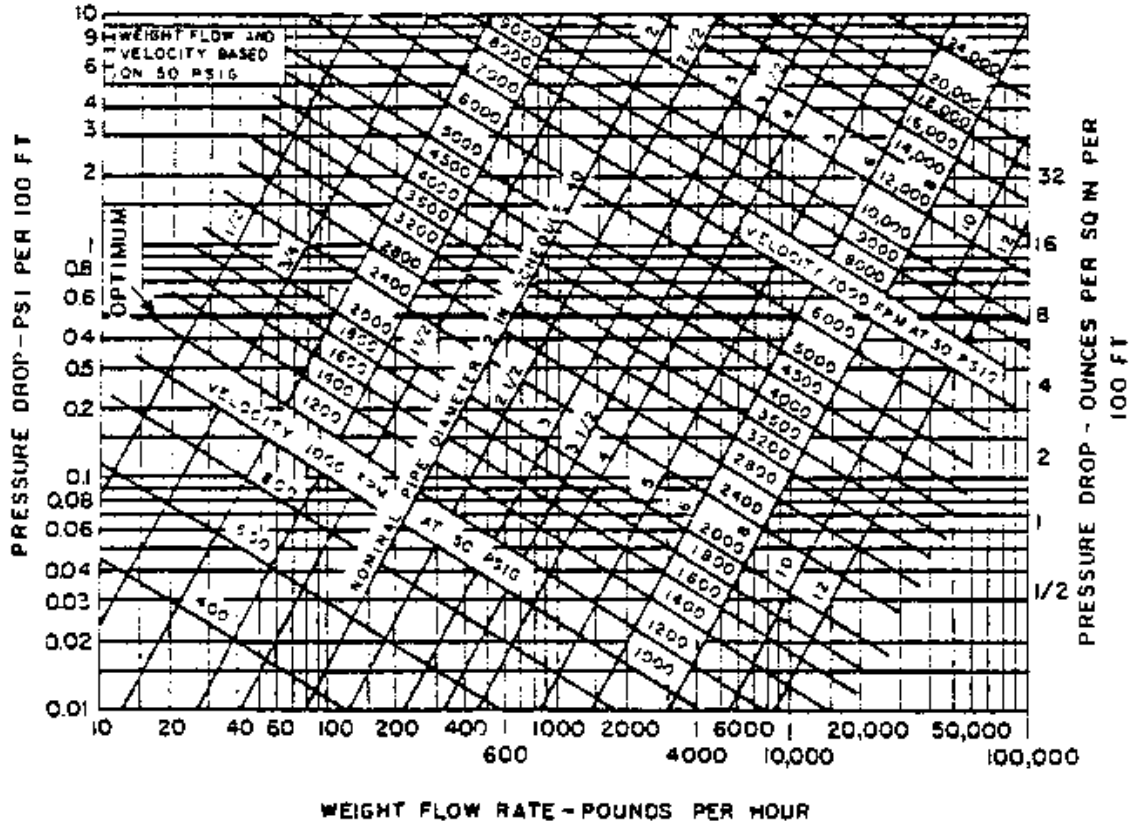

(MAY BE USED FOR STEAM PRESSURES FROM 40 TO 80 PSIG WITH AN ERROR NOT EXCEEDING 8 PERCENT) BASED ON MOODY FRICTION FACTOR WHERE FLOW OF CONDENSATE DOES NOT INHIBIT THE FLOW OF STEAM.

Table 2

Chart for weight-flow rate and velocity of steam (50 psig) (344.5 kPa)

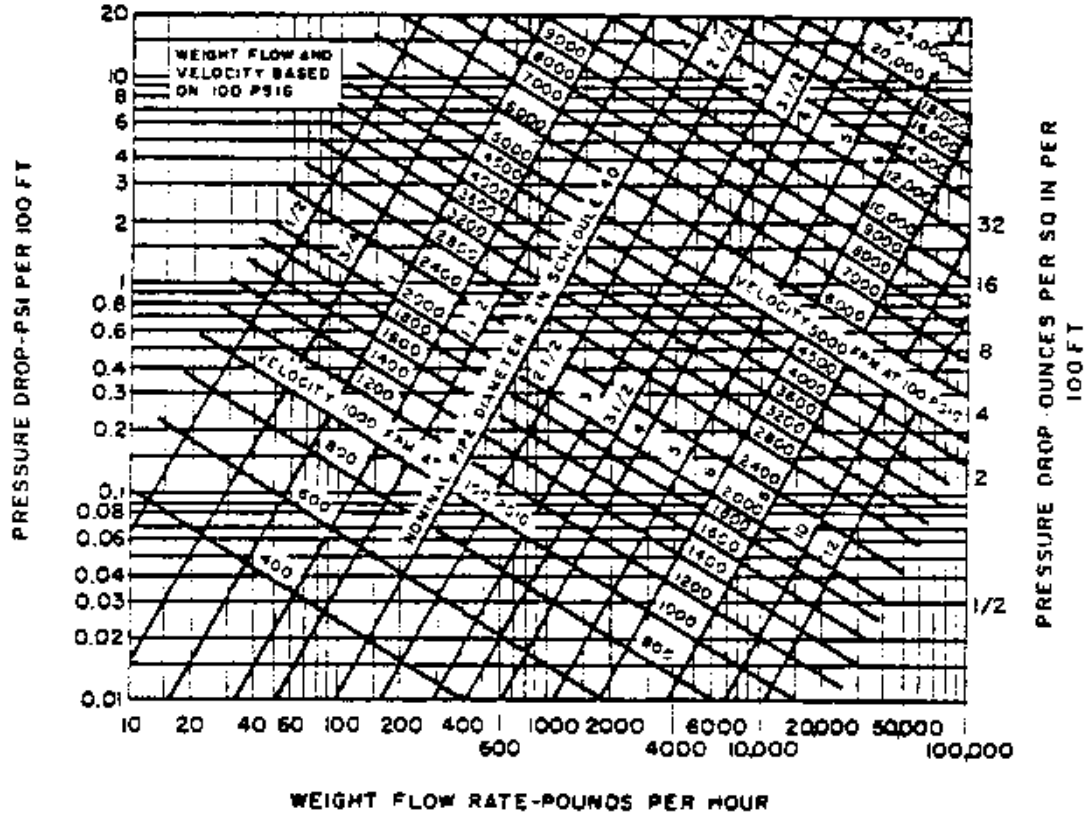

(MAY BE USED FOR STEAM PRESSURE FROM 85 TO 125 PSIG WITH AN ERROR NOT EXCEEDING 8 PERCENT) BASED ON MOODY FRICTION FACTOR WHERE FLOW OF CONDENSATE DOES NOT INHIBIT THE FLOW OF STEAM

Table 3

Chart for weight-flow rate and velocity of steam (100 psig) (689.4 kPa)

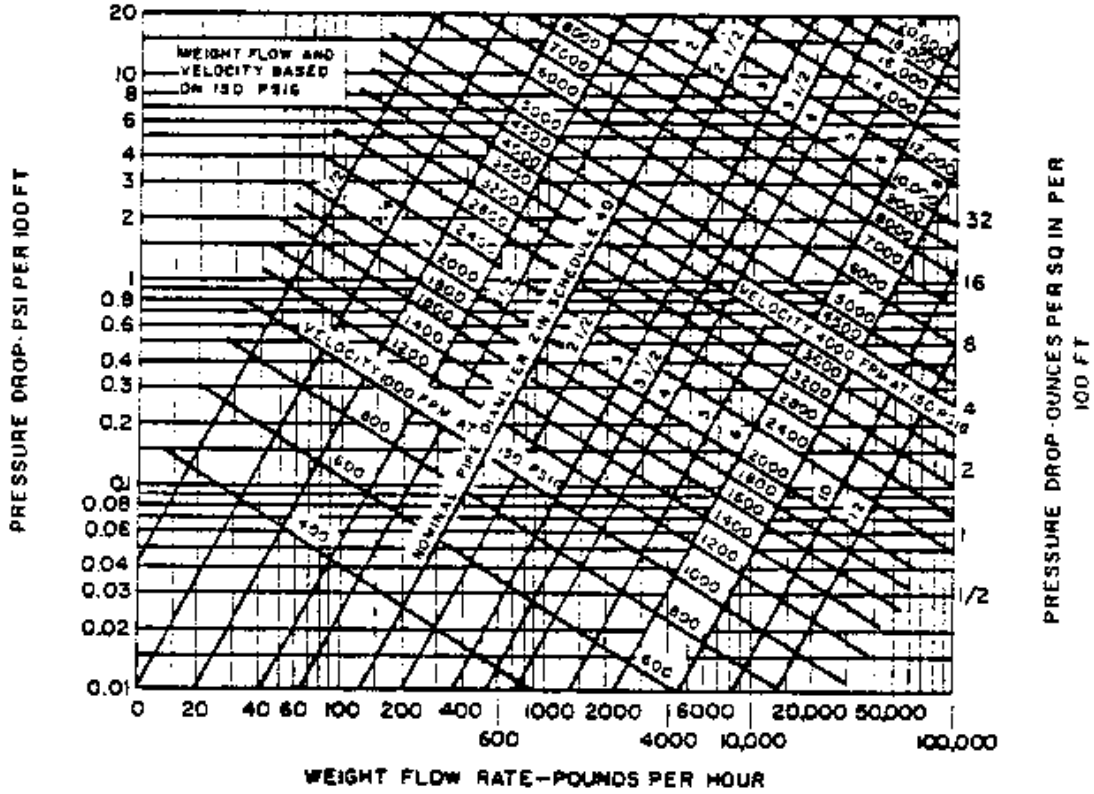

(MAY BE USED FOR STEAM PRESSURES FROM 127 TO 180 PSIG WITH AN ERROR NOT EXCEEDING 8 PERCENT) BASED ON MOODY FRICTION FACTOR WHERE FLOW OF CONDENSATE DOES NOT INHIBIT THE FLOW OF STEAM

Table 4

Chart for weight-flow rate and velocity of steam (150 psig) (1033.5 kPa)

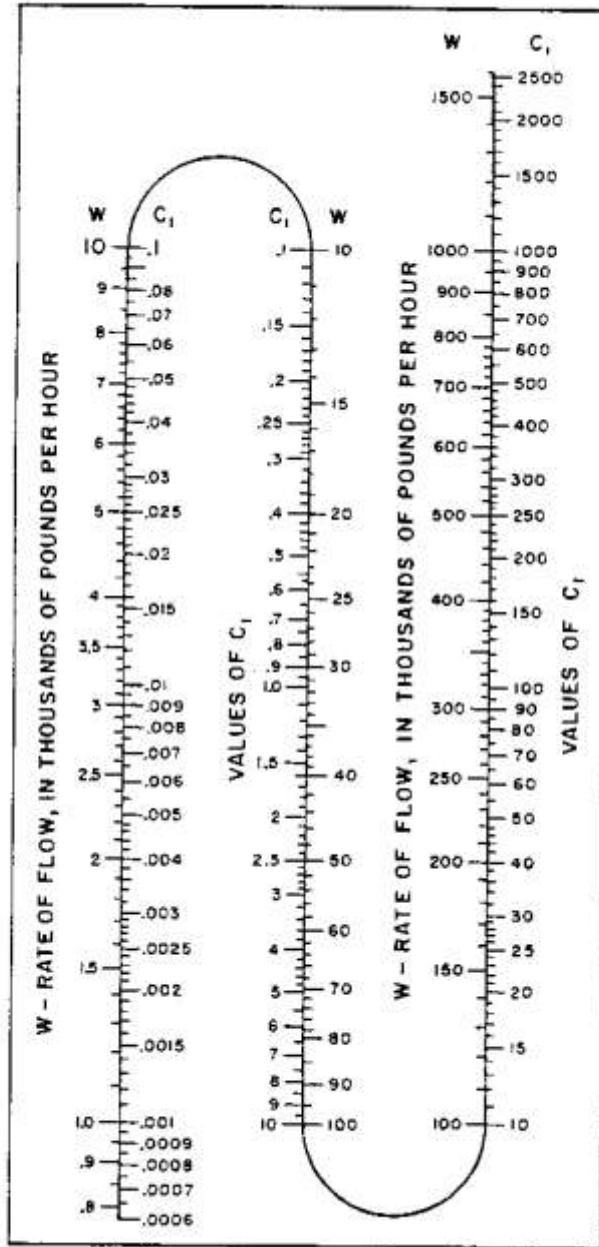

Figure 5  
Values of C<sub>1</sub> flow factor in equation 1

NOMINAL PIPE SIZE	SCHEDULE	VALUE OF C <sub>2</sub>	NOMINAL PIPE SIZE	SCHEDULE	VALUE OF C <sub>2</sub>
12	20	0.015	20	10	0.001
	30	0.016		20 S	0.001
	40 S	0.017		30 X	0.001
	40	0.018		40	0.001
	60 X	0.019		60	0.001
	60	0.020		80	0.023
	100	0.026		120	0.031
140	0.035	160	0.042		
14	10	0.009	24	10	0.000
	20	0.009		20 S	0.000
	30 S	0.010		30 X	0.000
	40	0.010		40	0.000
	40 X	0.011		60	0.000
	60	0.012		80	0.000
	80	0.014		100	0.000
	100	0.016		120	0.001
	120	0.018		140	0.001
	160	0.021		160	0.001
16	10	0.004	24	10	0.000
	20	0.004		20 S	0.000
	30 S	0.005		30 X	0.000
	40 X	0.005		40	0.000
	60	0.006		60	0.000
	80	0.007		80	0.000
	100	0.008		100	0.000
	120	0.009		120	0.001
	140	0.010		140	0.001
	160	0.012		160	0.001
18	10	0.002	24	10	0.000
	20	0.002		20 S	0.000
	30 S	0.002		30 X	0.000
	40 X	0.002		40	0.000
	60	0.003		60	0.000
	80	0.003		80	0.000
	100	0.004		100	0.000
	120	0.005		120	0.001
	140	0.005		140	0.001
	160	0.006		160	0.001

NOTE: The letters s, x, and xx in the columns of Schedule No. indicate Standard, Extra Strong, and Double Extra Strong pipe respectively.

Table 5  
Values of C<sub>2</sub> flow factor in equation 1

CONDITION OF STEAM	PRESSURE (psig)	SERVICE	REASONABLE VELOCITY [1] (fpm)
Saturated	Vacuum	Turbine exhaust	Up to 18,000
	0 to 25	Heating	4,000 to 6,000
	25 and up	Steam distribution	6,000 to 10,000
	125 and up	Underground steam distribution	Up to 20,000
Superheated	200 and up	Boiler and turbine leads	7,000 to 20,000

[1] Velocities should be below those which would produce excessive noise or erosion.

Table 6

Reasonable Velocities for Flow of Steam in Pipes

**d) STEAM DISTRIBUTION PRESSURES.** Steam pressure is governed by the highest pressure needed by the equipment served at the most remote location as well as by an economic analysis of the feasible systems, including pressure considerations. The advantages of a low-pressure system (under 15 psig) (103.4 kPa) are low distribution loss, lower losses and less trouble from leakage, traps, and venting, simplified pressure reduction at buildings, standard steel fittings, and low maintenance. The advantages of high-pressure distribution, over 50 psig (344.5 kPa), are smaller pipe sizes, availability of steam for purposes other than for heating, and more flexibility in velocities and pressure drops.

**e) SELECTION OF VALVE TYPES.** Install double-ported, pilot-operated valves for large capacities, especially for inlet pressures above 125 psig (861.3 kPa). Double-ported valves will not shut off completely on no-load demand; therefore, single-seated valves must be used for such services. Do not install reducing valves on the basis of pipe sizes, because oversized valves do not give satisfactory service. Select valves to operate generally fully open, with ratings and reduction ratios as recommended by the manufacturer. Install a strainer and condensate drain ahead of the pressure reducing valve. Because the volume of steam increases rapidly as the pressure is reduced, a reducing valve with increased outlet or expanding nozzle is required when the reduction ratio is more than 15 to 1. Provide cutout valves to isolate the pressure reducing valve to permit maintenance. Where the resulting superheated steam

temperature is objectionable to the process on the low pressure side or the temperature-use limit of the equipment has been exceeded, a desuperheater must be used to lower the steam temperature to that for saturation. Provide a manual bypass for emergency operation when the pressure reducing valve is out of service. Provide a pressure gauge on the low pressure side. Where steam requirements are relatively large, above approximately 3,000 pounds/hour (1364 kg/hr), and subject to seasonal variation, install two reducing valves in parallel, sized to pass 70 percent and 30 percent of maximum flow. During mild spring and fall weather, set the large valve at a slightly reduced pressure so that it will remain closed as long as the smaller valve can supply the demand. During the remainder of the heating season reverse the valve settings to keep the smaller one closed except when the larger one is unable to supply the demand.

**f) SAFETY VALVES.** Provide one or more relief or safety valves on the low pressure side of each reducing valve in case the piping and/or equipment on the low pressure side do not meet the requirements of the full initial pressure. The combined discharge capacity of the relief valves shall be such that the pressure rating of the lower pressure piping and equipment will not be exceeded. For special conditions refer to ASME B31.1 and ASHRAE Handbook - Systems and Applications.

**g) TAKEOFFS FROM MAINS.** Takeoffs from mains to buildings must be at the top of mains and located at fixed points of the mains, at or near anchor points. When a branch is short, valves at each takeoff are unnecessary. Takeoffs shall have valves when the branch is of considerable length or where several buildings are served. A 45 takeoff is preferred; 90 takeoffs are acceptable. Branch line slope of 1/2 inch (12.6 mm) should be used for lines less than 10 feet (3.05 m) in length and should be 1/2 inch per 10 feet (3.05 m) on branch lines longer than 10 feet.

**4.2.2.3 CONDENSATE RETURNS.** Condensate returns are preferred if owning and operating costs of such a system are less than that of using and treating raw water for makeup. Factors favoring condensate return are: high area concentration of steam usage; restriction on condensate disposal; high raw water treatment costs; water treatment space unavailable; high



cost of raw water; and high cost of fuel for feedwater heating. Design considerations are as follows:

**a) RETURN PIPING.** Size condensate trap piping to conform with 30 to 150 psig (206.7 to 1033.5 kPa) steam piping in accordance with Tables 7 and 8 and interpolate these for other pressures.

**b) DISCHARGE PIPING.** Size discharge piping from condensate and heating pumps in accordance with pump capacities, which may be between one to three times the capacity of the steam system branch which they serve, depending on whether continuously or intermittently operated.

DROP IN PRESSURE (psi PER 100 ft IN LENGTH)					
PIPE SIZE (in.)	1/8	1/4	1/2	3/4	1
3/4	115	170	245	308	365
1	230	340	490	615	730
1-1/4	485	710	1,025	1,290	1,530
1-1/2	790	1,160	1,670	2,100	2,500
2	1,580	2,360	3,400	4,300	5,050
2-1/2	2,650	3,900	5,600	7,100	8,400
3	4,850	7,100	10,300	12,900	15,300
3-1/2	7,200	10,600	15,300	19,200	22,800
4	10,200	15,000	21,600	27,000	32,300
5	19,000	27,800	40,300	55,500	60,000
6	31,000	45,500	65,500	83,000	98,000

(a) Based on 0-4 psig maximum return pressure.

Table 7  
Return Pipe Capacities for 30 psig (206.7 kPa) Steam Systems (a)  
(Capacity Expressed in lbs/hr)

DROP IN PRESSURE (psi PER 100 ft IN LENGTH)						
PIPE SIZE (in.)	1/8	1/4	1/2	3/4	1	2
3/4	156	232	360	465	560	890
1	313	462	690	910	1,120	1,780
1-1/4	650	960	1,500	1,950	2,330	3,700
1-1/2	1,070	1,580	2,460	3,160	3,800	6,100
2	2,160	3,300	4,950	6,400	7,700	12,300
2-1/2	3,600	5,350	8,200	10,700	12,800	20,400
3	6,500	9,600	15,000	19,500	23,300	37,200
3-1/2	9,600	14,400	22,300	28,700	34,500	55,000
4	13,700	20,500	31,600	40,500	49,200	78,500
5	25,600	38,100	58,500	76,000	91,500	146,000
6	42,000	62,500	96,000	125,000	150,000	238,000

(a) Based on 1-20 psig maximum return pressure.

Table 8  
Return Pipe Capacities for 150 psig (1033.5 kPa) Steam Systems (a)  
(Capacity Expressed in lbs/hr)

**c) COMMON PUMP DISCHARGE MAINS.** Size common pump discharge mains to serve the sum of their capacities. Use the Hydraulic Institute (HI) Pipe Friction Manual for steel pump discharge pipe sizing of new clean steel pipe, 6 feet per second (fps) (1.83 m/s) maximum velocity, and a correction factor of 1.85 to provide for increased pressure drops when the pipe becomes dirty and rough with age. Friction plus static heads shall not exceed the pump characteristics of standard pump and receiver units.

**4.2.2.4 HIGH TEMPERATURE WATER (HTW) PIPING.** High temperature water piping is as follows:

**a) SIZING PIPING.** Use pipe friction charts in ASHRAE 1985 Handbook Fundamentals. These charts are based on the rational flow formula using clean pipe. A reasonable average velocity is approximately 5 fps (1.53 m/s). The minimum allowable velocity is 2 fps (0.61 m/s).

**b) VENTING AND DRAINING.** For methods of venting high points of distribution lines, refer to owner's criteria. Piping must have drainage means at low points.

**4.2.2.5 CHILLED WATER PIPING.** Use the standards of the Hydraulic Institute Pipe Friction Manual for sizing new clean pipe, unless water is renewed annually, in which case a correction factor of 1.41 for pressure drop is also to be used. For recommended velocities, refer to owner's criteria.

**4.2.2.6 CONDENSER WATER PIPING.** Use the standards of the Hydraulic Institute Pipe Friction Manual for pipe sizing, multiplying the pressure drop by a factor of 1.85 to correct for the increase of pipe roughness with age. For recommended velocities, refer to owner's criteria. No correction factor is required for RTRP pipe.

**4.2.2.7 NATURAL GAS PIPING.** Apply owner's criteria for sizing pipe inside buildings. Use Figure 6 for low volume flow rates and Figure 7 for high volume flow rates in sizing distribution piping. Using these figures will simplify design of piping by indicating required diameter, maximum rate of flow, permissible pressure drop, initial pressure, or final pressure

when the rest of these values are known. These charts are based on the Weymouth formula for rate of flow in cubic feet of gas per hour. (The chart is based upon the following conditions: gas at 60 degrees F (15.5 degrees C) and specific gravity of 0.60, with air = 1.0.). Exterior distribution piping usually stops 5 feet (1.53 m) outside of buildings.

**4.2.2.8 COMPRESSED AIR.** For criteria on distribution piping, refer owner's criteria.

**4.2.3 PIPING SPECIFICATIONS AND CODES.** Piping specifications and codes are as follows:

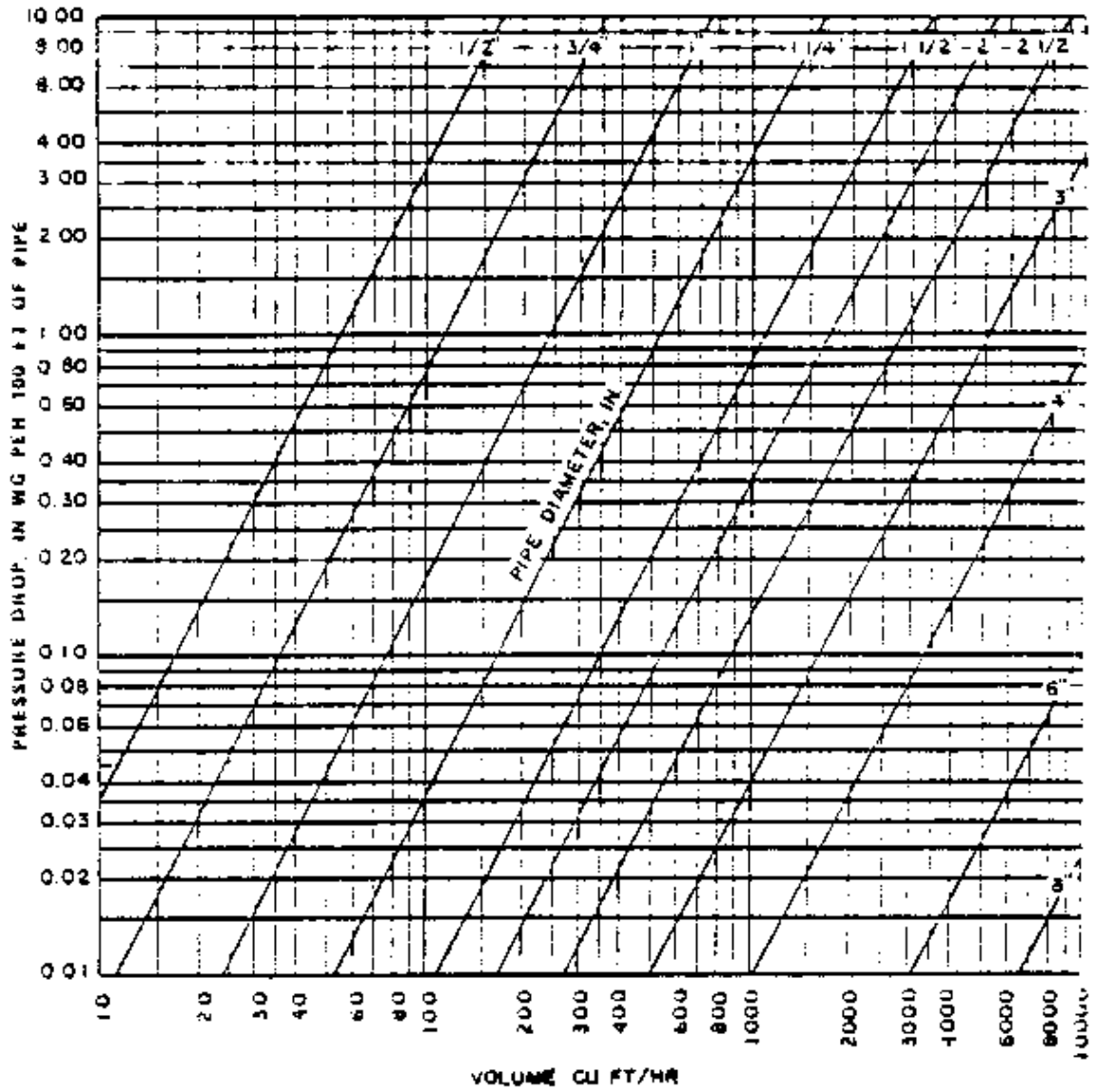

Figure 6

Low volume flow rate natural gas chart (10 to 10,000 cf/hr)

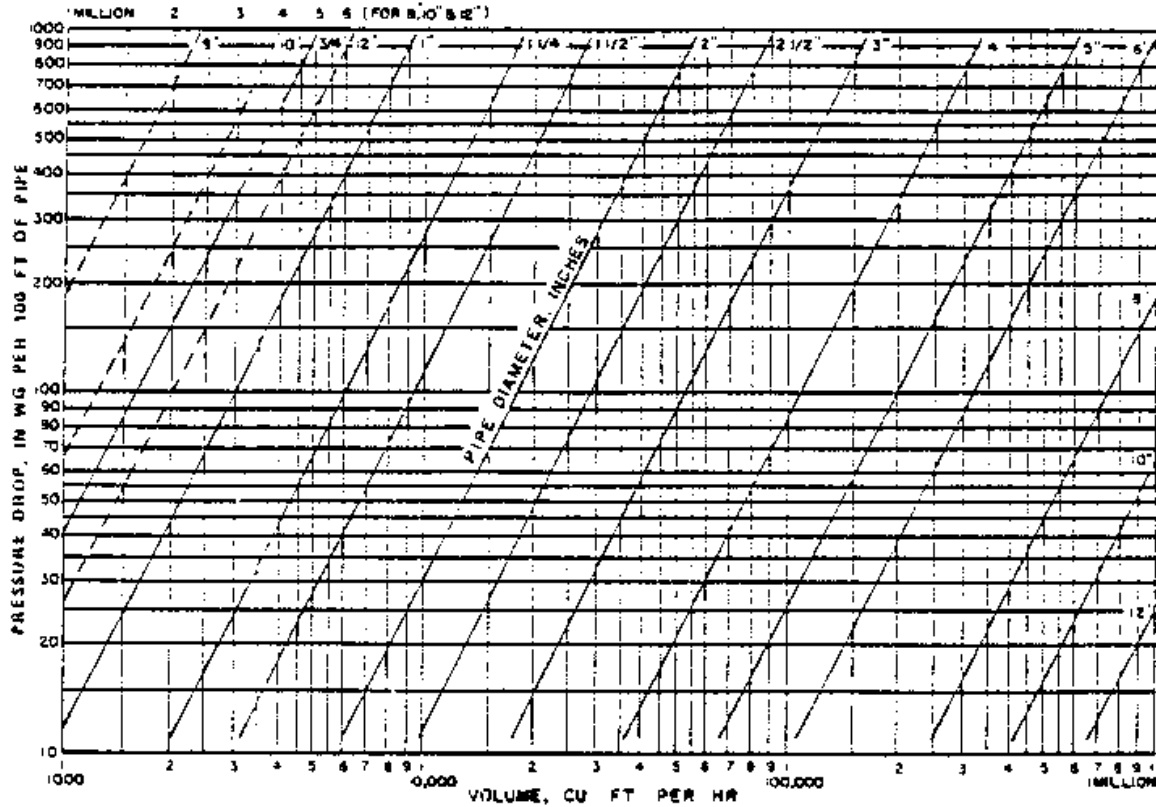

Figure 7

High volume flow rate natural gas chart (1,000 to 1 million cf/hr)

**4.2.3.1 STEAM SUPPLY AND CONDENSATE RETURN.** Piping shall conform to ASME B31.1, except for underground prefabricated or pre-engineered type systems, in which case the entire system shall conform to the owner’s requirements.

- a) If a separate pump condensate return system is used, it shall conform to the owner’s requirements.
- b) For condensate provided as a part of an underground prefabricated, pre-engineered system, include owner-approved plastic condensate piping in the specification as a Contractor's option for sites classified B, C, or D. Plastic piping is optional but encouraged for sites classified A. The Contracting Officer shall give specific approval for plastic condensate piping in Class A systems. Take particular care that the failure of high pressure steam drip traps shall not discharge high temperatures and pressures into the plastic condensate piping.

**4.2.3.2 HIGH TEMPERATURE WATER, MEDIUM TEMPERATURE WATER, AND LOW TEMPERATURE HOT WATER.** Piping specifications and codes are as follows, except for underground prefabricated or pre-engineered types, in which case the entire system shall conform to the owner's requirements.

**a) PIPING.** HTW metallic piping (450 degrees F maximum) (232 degrees C) and medium temperature water metallic piping shall conform to ASME B31.1.

**b) JOINTS.** Welded joints are preferred. Threaded joints are not permitted. Hold flanged joints to a minimum and use ferrous alloy gaskets in such joints. Avoid the use of copper and brass pipe.

**c) VALVES.** All valves shall have cast steel bodies with stainless steel trim (no bronze trim). All valves shall be capable of being repacked under operational pressures. Use gate valves only as shutoff or isolation valves.

**4.2.3.3 NATURAL GAS AND COMPRESSED AIR.** Piping shall conform to ASME B31.1 and B31.8 including guidance for abandoning existing gas lines. Note that ASME B31.8 requires that abandoned gas lines be physically disconnected from gas sources and purged prior to sealing. Shutoff valves are not an acceptable means of disconnect. Cathodic protection systems on lines to be abandoned should be evaluated for modifications required to ensure continuity of the systems after abandoned lines are disconnected or removed. Provide excess flow (earthquake) shutoff valves in gas supply piping outside of each building served in earthquake zones 3 and 4. In addition, provide flexible connections. Gas piping and appurtenances from point of connection with existing system to a point approximately 5 feet (1.53 m) from the building shall conform to the owner's requirements.

**4.2.3.4 CHILLED AND CONDENSER WATER.** Use Schedule 40 steel pipe in 10-inch (254 mm) size and smaller, and use 1/2-inch (12.5 mm) wall thickness steel pipe for 12-inch (305

mm) size and larger. RTRP pipe and PVC pipe are also acceptable. RTRP pipe and PVC pipe are available in 2 through 12-inch (51 through 305-mm) pipe sizes.

**4.2.4 THERMAL EXPANSION OF STEEL AND COPPER PIPE.** Pipe expands with temperature increases (such as between installation and operating temperatures) as indicated in Table 9. Make provisions for the control of expansion in any piping system where thermal expansion is a factor. Wherever possible, provide for expansion of pipes by changes in direction of pipe runs.

**4.2.4.1 BRANCH LINES.** Where practicable, design branch line piping to provide for expansion inside buildings. Expansion control of branch lines should be designed so as to have no effect on mains.

**4.2.4.2 EXPANSION BENDS.** Bends are to be factory fabricated except for RTRP pipe.

**a) LOOP SECTIONS.** Loops may be furnished in sections to facilitate delivery and handling.

**b) ANCHORS.** A reasonable distance between anchors for expansion loops is 200 feet (61 mm) for 125 psig (861.3 kPa) steam system. Expansion is usually kept at about 6 inches (150 mm) between anchors.

**c) COLD SPRINGING.** Cold springing may be used in installations but no design stress relief is allowed for it. For credit permitted in thrust and moments, refer to ANSI B31.1.

**4.2.4.3 EXPANSION JOINTS.** Install expansion joints only where space restrictions prevent the use of other means. When necessary to use, expansion joints shall be in an accessible location and shall be one of the following types:

**a) MECHANICAL SLIP JOINT.** An externally guided joint designed for repacking under operating pressures. Hold maximum traverse of piping in expansion joints under 8 inches (203 mm).



**b) BELLOWS TYPE JOINT.** Use these joints on steel pipe for thermal expansion with stainless steel bellows, guided and installed according to manufacturer's instructions. Make bellows or corrugations for absorbing vibrations or mechanical movements at ambient temperatures of copper or other materials suitable for the job conditions. A maximum travel of 4 inches (102 mm) is allowed for this type. RTRP expansion joints may be polytetrafluoroethylene bellows type.

**c) FLEXIBLE BALL JOINTS.** Install these joints according to manufacturer's instructions.

**4.2.4.4 FLEXIBILITY ANALYSIS.** Refer to ASME B31.1 for expansion and flexibility criteria and allowable stresses and reactions.

CHANGE IN TEMPERATURE (Degrees F)	MATERIAL		CHANGE IN TEMPERATURE (Degrees F)	MATERIAL	
	STEEL	COPPER		STEEL	COPPER
0	0	0	390	3.156	4.532
10	0.075	0.111	400	3.245	4.653
20	0.149	0.222	410	3.334	4.777
30	0.224	0.333	420	3.423	4.899
40	0.299	0.444	430	3.513	5.023
50	0.374	0.556	440	3.603	5.145
60	0.449	0.668	450	3.695	5.269
70	0.525	0.780	460	3.785	5.394
80	0.601	0.893	470	3.874	5.519
90	0.678	1.006	480	3.962	5.643
100	0.755	1.119	490	4.055	5.767
110	0.831	1.233	500	4.151	5.892
120	0.909	1.346	520	4.342	6.144
130	0.987	1.460	540	4.525	6.396
140	1.066	1.575	560	4.715	6.650
150	1.145	1.690	580	4.903	6.905
160	1.224	1.805	600	5.096	7.160
170	1.304	1.919	620	5.291	7.417
180	1.384	2.035	640	5.486	7.677
190	1.464	2.152	660	5.583	7.938
200	1.545	2.268	680	5.882	8.197
210	1.626	2.384	700	6.083	8.460
220	1.708	2.501	720	6.284	8.722
230	1.791	2.618	740	6.488	8.988
240	1.872	2.736	760	6.692	9.252
250	1.955	2.854	780	6.899	9.519
260	2.038	2.971	800	7.102	9.783
270	2.132	3.089	820	7.318	10.056
280	2.207	3.208	840	7.529	10.327
290	2.291	3.327	860	7.741	10.598
300	2.376	3.446	880	7.956	10.872
310	2.460	3.565	900	8.172	11.144
320	2.547	3.685	920	8.389	11.420
330	2.632	3.805	940	8.608	11.696
340	2.718	3.926	960	8.830	11.973
350	2.805	4.050	980	9.052	12.253
360	2.892	4.167	1,000	9.275	12.532
370	2.980	4.289	1,000	10.042	13.950
380	3.069	4.411	1,200	11.598	15.397

Table 9  
 Pipe Expansion in Inches Per 100 Feet (30.5 m) of Length  
 for Temperature Shown

**4.2.4.5 STRESS ANALYSIS.** For methods of analyzing stresses in piping systems, use piping handbooks and publications of pipe and pipe fitting manufacturers. These manufacturers also supply calculation forms and charts. Keep calculated pipe stresses under those allowed by ANSI B31.1.

**4.2.5 INSULATION OF PIPING SYSTEMS.** Insulate as required by owner.

**4.2.5.1 INSULATION THICKNESS.** Insulation thicknesses shall conform to owner requirements. However, in locations where extreme annual temperatures occur, the project designer should evaluate different thicknesses of insulation. Make final selection based on an economic analysis.

**4.2.5.2 JACKETS.** Design insulation jackets in waterfront or other locations subject to flooding to drain; they shall not be watertight.

**4.2.6 DRAINAGE PROVISIONS.** Drainage provisions must conform to requirements listed below.

**4.2.6.1 PITCH.** The surrounding terrain and piping application both affect the pitch of piping as indicated below.

**4.2.6.1.1 HORIZONTAL PIPING.** Pitch horizontal steam piping down at a minimum of 2-1/2 inches (64 mm) per 100 feet (30.5 m) of length in the direction of steam flow.

**4.2.6.1.2 UNDERGROUND PIPING.** Pitch horizontal piping down towards drain points (unless otherwise noted) a minimum of 2-1/2 inches (64 mm) in 100 feet (30.5 m). Where the ground surface slopes in the opposite direction to steam piping, step up underground piping in vertical risers at drip points in manholes, and pitch them down to the next drip point. Use this method also for all very long horizontal runs, above- or belowground, to keep piping within a reasonable range of elevations with reference to the ground surface.

**4.2.6.1.3 COUNTER-FLOW CONDITIONS.** Where counter-flow of condensate within the steam pipe may occur in a portion of a pipeline because the stepped construction cannot be built, or because of steam flow reversal in a loop system, pitch that portion up in the direction of steam flow a minimum of 6 inches (152 mm) per 100 feet (30.5 m) and increase pipe diameter by one standard pipe size.

**4.2.6.1.4 COMPRESSED AIR AND NATURAL GAS LINES.** Pitch compressed air and gas piping as for steam piping.

**4.2.6.1.5 PUMPED WATER PIPE.** Pitch pumped water pipes (condensate, HTW, MTW, LTW, CHW, or condenser water) up or down in direction of flow at a minimum slope of 2-1/2 inches (64 mm) per 100-foot (30.5 m) length. Place drain valves at all low points and vents at high points.

**4.2.6.2 DRIPS AND VENTS.** Provide drips and vents as follows:

**4.2.6.2.1 DRIP LEGS.** Provide drip legs to collect condensate from steam piping and compressed air piping for removal by automatic moisture traps, or by manual drain valves for compressed air piping when practicable. Locate drip legs at low points, at the bottom of all risers, and at intervals of approximately 200 to 300 feet (61 to 91.5 m) for horizontally pitched pipe where a trap is accessible, and not over 500 feet (152.5 m) for buried underground pipe systems. On gas piping, drip legs are not usually required where dry gas is provided. Where there is moisture in the gas, provide drip legs and sediment traps in accordance with NFPA 54. Automatic traps are not utilized.

**4.2.6.2.2 WATER PIPING.** Vent piping, especially high-temperature water piping, at distribution piping high points.

**4.2.6.2.3 FUEL GAS PIPING.** Provide capped dirt traps in vertical risers upstream of gas-burning devices.

**4.2.6.3 CONDENSATE SYSTEMS.** Condensate systems are as follows:

- a) Furnish a complete system of drip traps and piping to drain all steam piping of condensate from drip legs. Ensure drip piping to traps is the same weight and material as the drained piping.
  
- b) Preferably, run a condensate line from a trap separately to a gravity condensate return main or to a nearby flash tank. (Refer to ASHRAE Handbooks - Systems and Applications for flash tank details and specific trap applications. However, a trap may be discharged through a check valve into the pumped condensate line if pressure in the trap discharge line exceeds the back pressure in the pumped condensate line during standby time of an intermittently operated pump. If the pumped condensate line is RTRP pipe, install a condensate cooling device, similar to that shown in Figure 8, to limit temperature of the condensate entering the line to less than 250 degrees F (121 degrees C).
  
- c) Select traps using a safety load factor no greater than 2. The condensate load should be indicated on design drawings and may be determined for aboveground lines by using Table 10. The condensate load for underground distribution lines is determined from maximum heat loss as indicated by the design. With the tight safety load factor for sizing traps, an alternate method of expelling gasses during warmup is required. To this end, all strainers should have blowdown valves which will also be used for controlled warmup.

STEAM PRESSURE (psig)	STEAM PIPE SIZE (INCHES, DIAMETER)					
	2	4	6	8	10	12
10	6	12	16	20	24	30
30	10	18	25	32	40	46
60	13	22	32	41	51	58
125	17	30	44	55	68	80
300	25	46	64	83	203	122
600	37	68	95	124	154	182

Table 10  
 Condensate Loads from Aboveground Heat Distribution Piping  
 (Pounds Per Hour Per 100 Linear Feet)

d) Pitch discharge piping down a minimum of 3 inches (76 mm) per 100 feet (30.5 m) to the collection tank. This applies where a condensate pump set or reliance upon a gravity return is used. An exception to this "rule-of-thumb" exists when there is sufficient pressure in a steam line to overcome its friction and static head, whether the line is level, or pitched up. Trap discharge line shall not be RTRP pipe nor shall the trap discharge connect to an RTRP pipe by direction connection. Install pipe through a condensate cooling device as depicted in Figure 8. This system provides a cooling tank and diffuser, plus a temperature relief valve to limit the temperature of condensate returned to a pumped RTRP condensate line to less than 250 degrees F (121 degrees C).

e) If it is not justifiable to return drips to a condensate system, they may be drained as waste to a sewer. If the temperature exceeds sewer limitations, condensate must be cooled in a sump or by other means. Disposal of condensate from steam systems along the waterfront or under piers warrants special consideration to be determined on a case-by-case basis.

**4.2.7 PIPE ANCHORS.** Ensure anchors comply with the following criteria:

**4.2.7.1 LOCATION.** Locate anchors for non-pre-engineered/prefabricated systems at takeoffs from mains and other necessary points to contain pipeline expansion. If possible, locate anchors in buildings, piers, tunnels, and manholes with suitable access.

**4.2.7.2 SPECIFICATION.** Design and locate anchors in accordance with ASME B31.1.

**4.2.7.3 STRENGTH.** Design anchors to withstand expansion reactions. With expansion joints, consider the additional end reactions due to internal fluid pressure, and add end reactions due to spring rate of the joint.

**4.2.7.4 GUYING.** Anchors for elevated aboveground systems shall consist of wire rope guys running from embedded concrete deadmen to pipe saddles welded to the pipe and secured to the vertical support(s). Guy in both directions. Guys may be located on the diagonal to serve also as sway bracing.

**4.2.7.5 EMBEDDING.** In underground concrete tunnels, the ends of structural steel shapes anchoring a pipe may be embedded in the tunnel walls or floors.

**4.2.8 SUPPORTS.** Insure pipe supports conform to ASME B31.1.

**4.2.8.1 LOW ELEVATIONS.** For aboveground systems at low elevations (defined as lower than 5 feet (1.53 m) above grade or the working surface), use and space concrete pedestals, steel frames, or treated wood frames as required depending on pipe sizes.

**4.2.8.2 HIGH ELEVATIONS.** At higher elevations above ground, support pipelines on wood, steel pipe, H-section steel, reinforced concrete, prestressed concrete poles with crossarms, or steel frameworks fitted with rollers and insulation saddles. (See Figure 9.) Details of design will vary depending on site conditions.

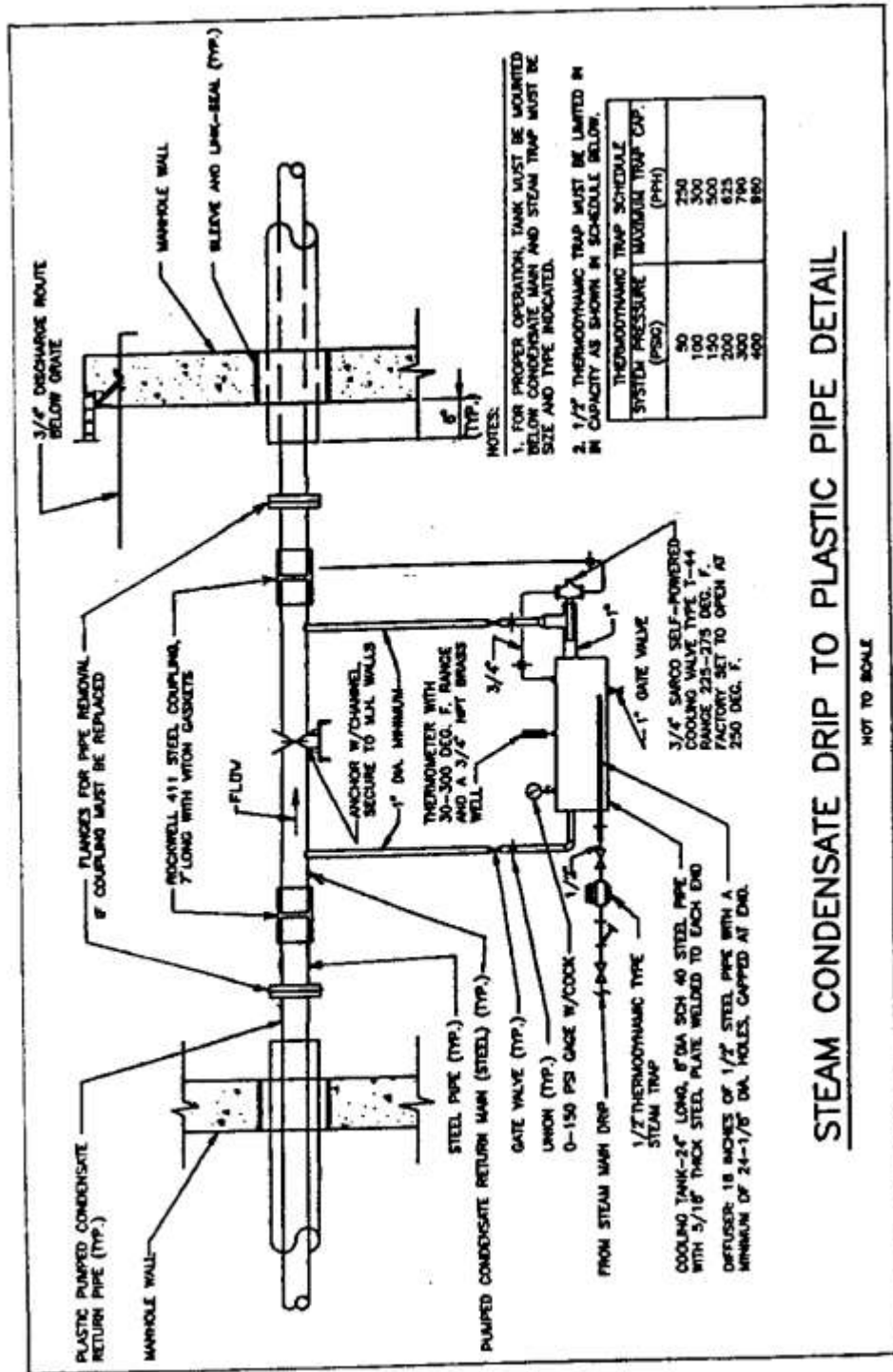

Figure 8

Protective arrangement for RTRP pipe



**4.2.8.3 LONG SPANS.** When long spans are necessary, cable-suspension or catenary systems may be used.

**4.2.8.4 UNDERGROUND CONDUITS.** Use approved types of manufacturers' standard designs supports for underground conduits.

**4.2.8.5 IN TRENCH.** Suspend pipes either from the walls or the tops of the walls. Do not support piping from either the floor of the trench or from the removable top. The pipe hanger design must provide for adequate system expansion and contraction.

**4.2.9 FINISH AND PROTECTION.** All noninsulated ferrous parts of the piping, piping support system, or equipment will be hot-dipped galvanized or primed with red oxide primer and painted with epoxy paint.

**4.3 CONCRETE TRENCH DESIGN.** The concrete shallow trench will consist of poured concrete sides and floor, with removable tops. Portions of the floor may be omitted at locations outlined previously under coarse grained soils with water table 2 feet (610 mm) or more below lowest point of water entry.

**4.3.1 DEPTH OF TRENCH.** Ensure the depth of the concrete trench is sufficient to provide adequate protection to the piping system and, slope the floor of the trench to provide adequate internal drainage, but in all cases not less than 6 inches (150 mm) from the bottom surface of the suspended pipe insulation to the floor of the trench. Ensure there is a minimum of 3 inches (75 mm) between the surface of the pipe insulation and the adjoining trench walls and a minimum of 4 inches (100 mm) between surfaces of adjacent pipe insulation.

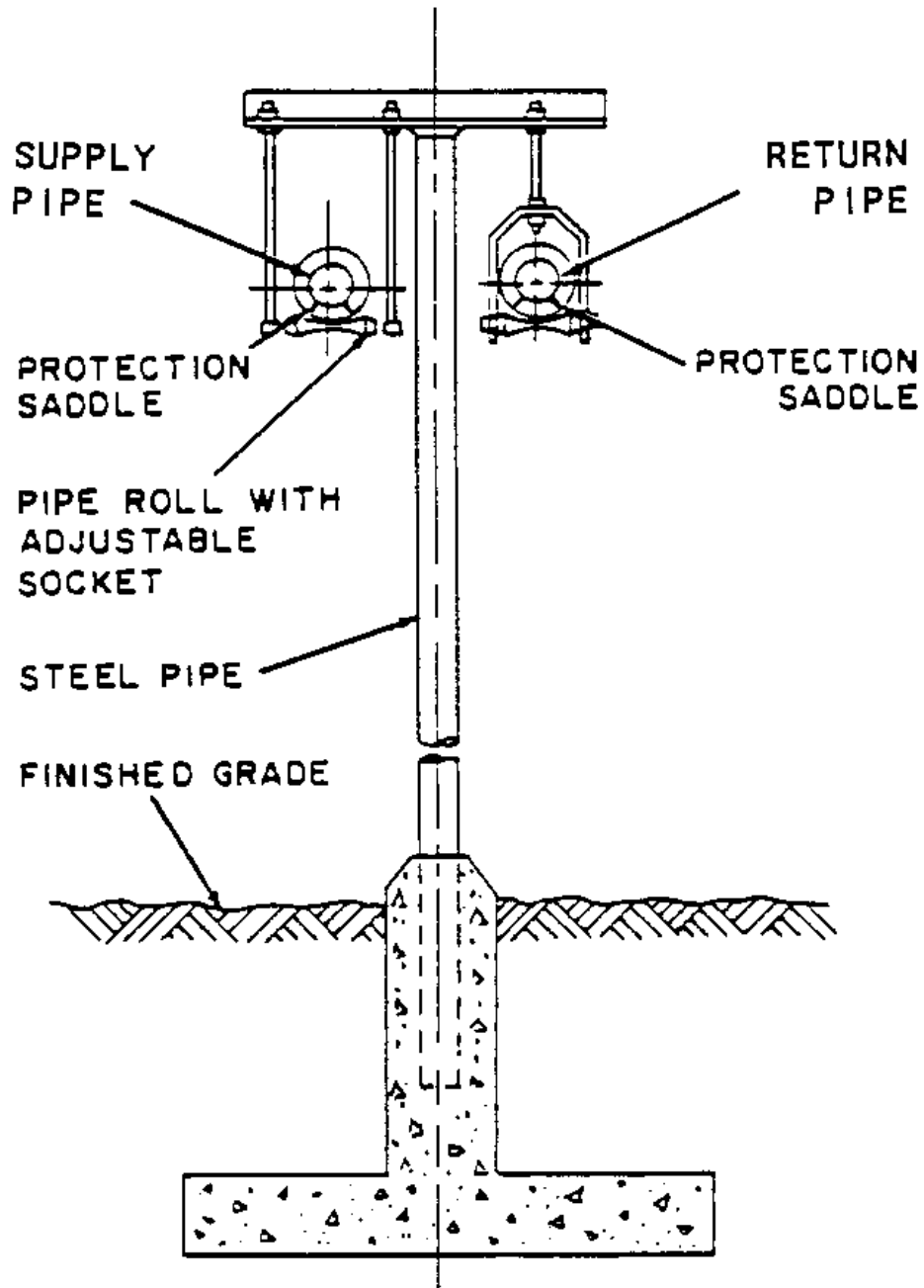

Figure 9

Typical aboveground pipe supports

**4.3.2 DRAINAGE OF TRENCH.** Base the design on sound engineering practices which provide for drainage under all anticipated conditions. Consider the annual rainfall, water table, and other topographic conditions in the basis for the design. For those instances where natural drainage cannot be provided (storm water drainage system at least 2 feet (610 mm) below trench bottom at all times), provide a dual sump pump capability with failure annunciator.

**4.3.3 TOPS.** The tops of the concrete trenches will be removable by use of a portable lifting device such as a forklift or backhoe, and can also be used for sidewalks, if practical. Earth must not cover the tops. Covers will be close tolerance fit with a maximum gap tolerance buildup of 0.12 inch from all causes.

**4.3.4 DETAILS.** Design the Concrete Shallow Trench Heat Distribution System and show on the contract drawings. Use Figures 10 through 21 as appropriate. Provide the following information on the contract drawings for the concrete Shallow Trench System, as applicable: dimension on all runs of pipe; elevations of the pipe along the systems path; sizes of the pipe; location of all valves; location and details of all expansion loops, Z- and L-bends; location of pipe anchors; how changes in pipe direction are made; thickness of the insulation on the pipe; concrete trench details; final elevations of concrete trench; profile of trench showing all existing utilities; manhole dimensions; manhole cover details; how manhole is drained and vented where required; sump pump piping details; sump pump capacity; condensate pump capacity and details; include specific requirements for modification to existing; steam drip trap locations and capacity; steam pressure reducing valve capacity and details; and other pertinent information and details required to clearly show the intent of the Shallow Trench Heat Distribution System. Also indicate any obstructions in the path of the distribution system that the Contractor may have to work around.

**4.3.5 VALVE MANHOLES.** Extend valve manholes at least 9 to 12 inches (175 to 305 mm) above finished grade to prevent seasonal runoff from entering except where trench will be a pedestrian walk, in which case the vault cover will be flush with the trench covers.

**4.3.6 INSPECTION PORTS.** Where required, provide inspection ports at appropriate locations to enable the user to observe drains or expansion at loops or locations requiring frequent (monthly) observation.

**4.3.7 CROSSINGS.** At all road and railroad type crossings, provide required slab thickness for railroad crossings and H-20 loading for street crossings. Review railroad track removal/replacement with respective authority and coordinate all activities. Road and rail crossing where maintenance of traffic is critical may be accomplished by jacking using an acceptable conduit/tunnel.

**4.3.8 PRECAST CONCRETE SHALLOW TRENCH OPTIONS.** In addition to or in combination with a poured-in-place concrete shallow trench system, a precast or prefabricated shallow trench system consisting of precast concrete covers, concrete trench, or supports may be specified. If the designer selects this option, he must include special details and specification requirements of the precast system and the transition between the poured-in-place and precast system.

#### **4.4 MANHOLES**

**4.4.1 DRAINAGE.** Provide sump pumps in manholes. Units should discharge by buried piping to nearest storm sewer if possible. Where not economical to discharge to storm sewer, pumps are to discharge above grade to splashblocks. Plan discharge locations carefully so water will not be placed over tunnel tops, sidewalks, etc. Use sump pumps capable of passing 3/8-inch (12 mm) solid (sphere) minimum. Adjust float switches so the pumps start sequentially, reducing electrical line surge. Coordinate power requirements with electrical designer and provide tell-tale light above ground to indicate that power is available to sump pumps.

**4.4.2 WATERPROOFING.** If portions of manholes are installed below the water table, waterproof that portion below the water table.

**4.4.3 PIPE ENTRY.** Pipe entry, for buried pre-engineered systems piping, shall be in accordance with Figure 22.

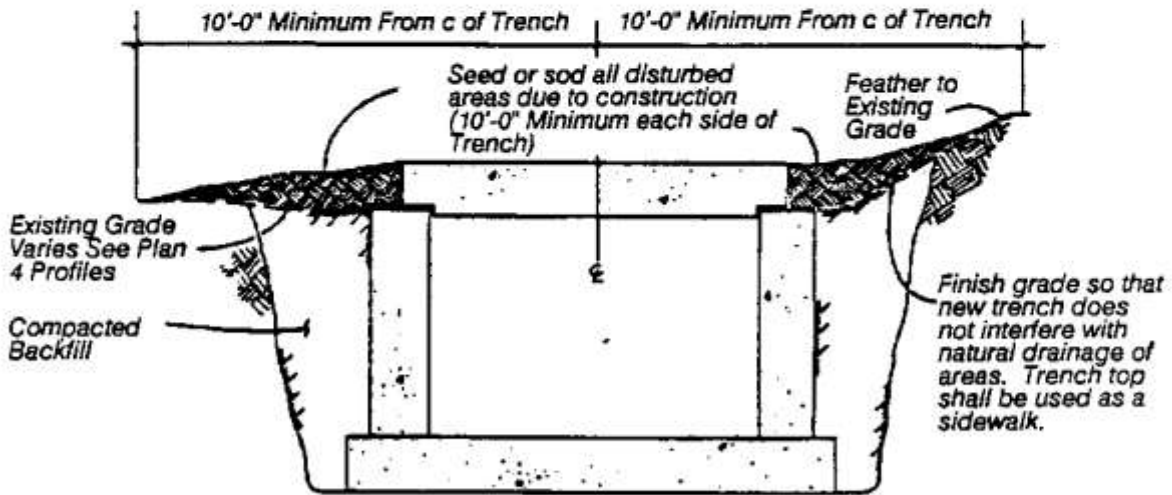
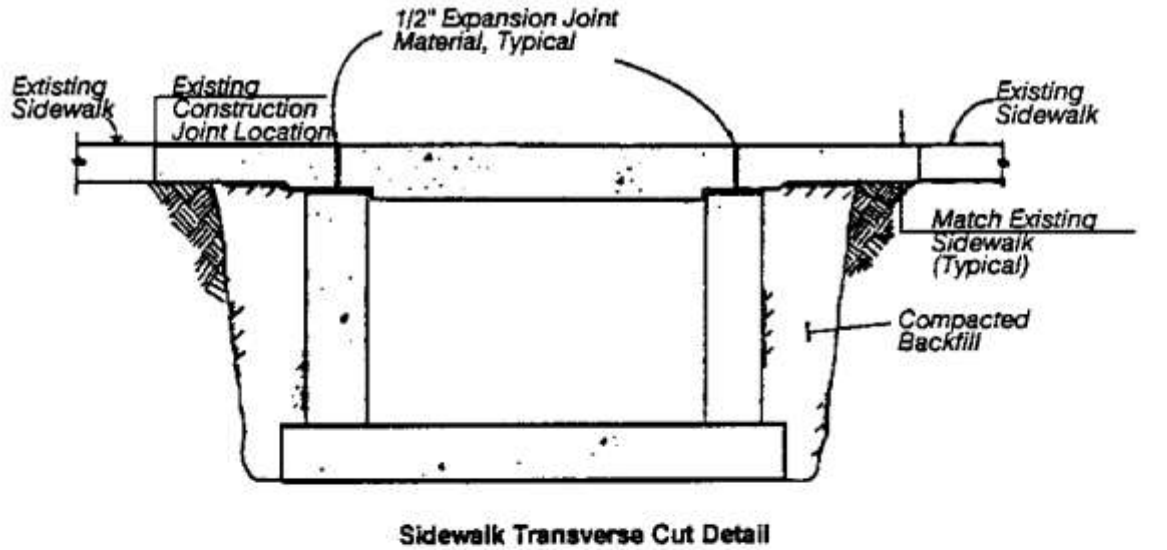

**Note:**  
Trench floors must be sloped to provide continuous drainage to sump pumps in manholes. All pockets found in trench floor shall be provided with a floor drain to the nearest manhole sump or the floor shall be sloped to provide gravity drainage.

Figure 10  
Concrete shallow trench heat distribution system, Detail 1

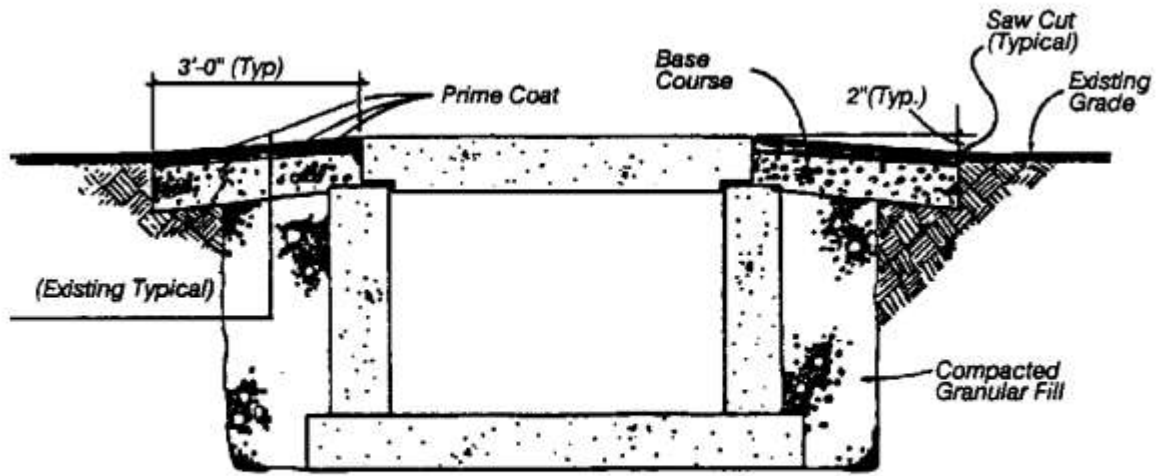

**Parking Lot Pavement Cut Detail**

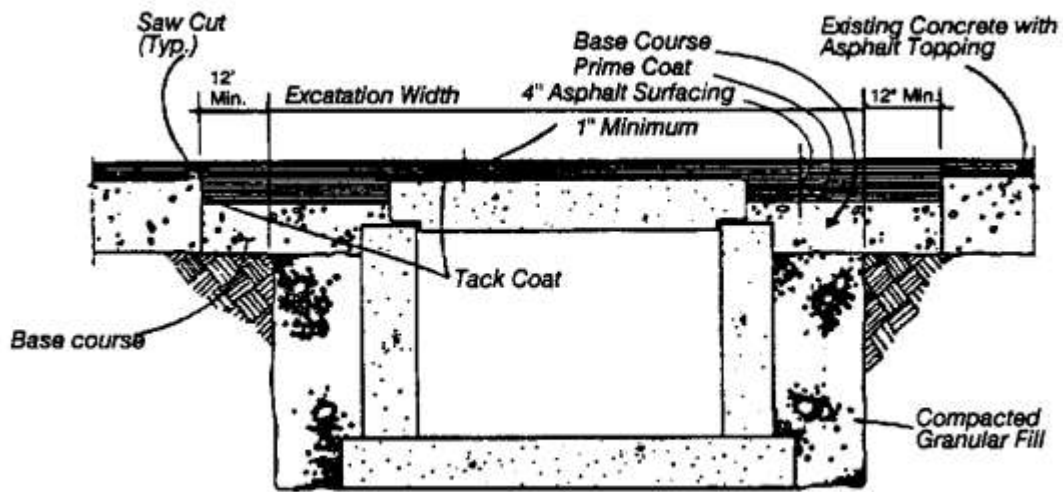

**Street Pavement Cut Detail**

Figure 11

Concrete shallow trench heat distribution system, Detail 2

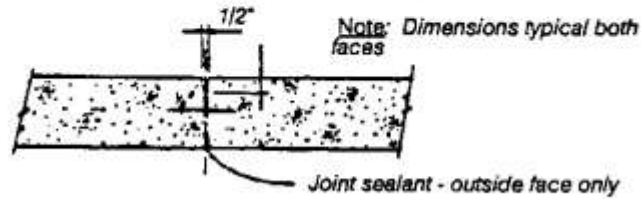
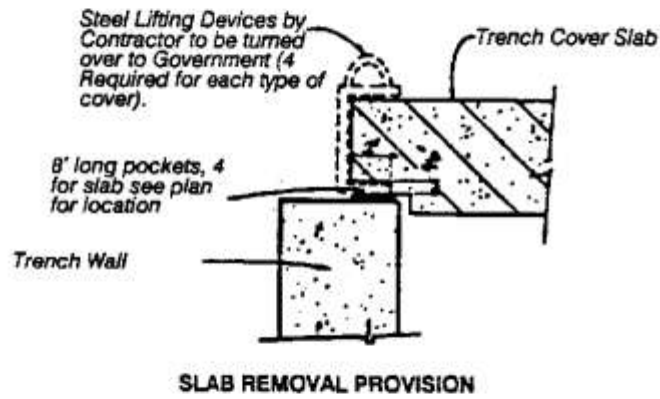
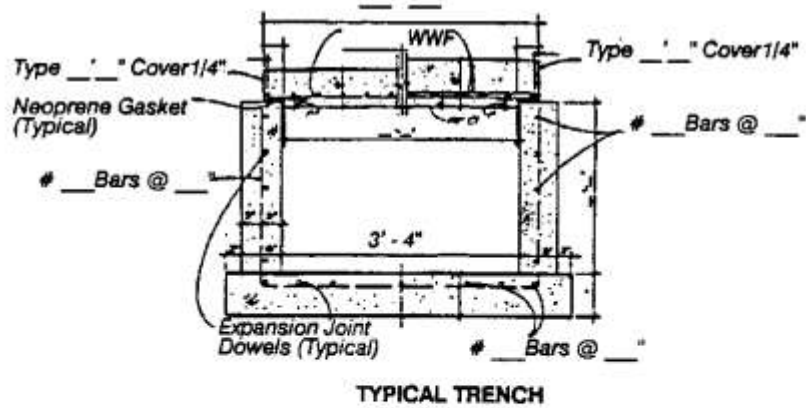

**TYPICAL TRENCH WALL CONTROL JOINT  
MAXIMUM SPACING 20'0"**

Figure 12  
Concrete shallow trench heat distribution system, Detail 3



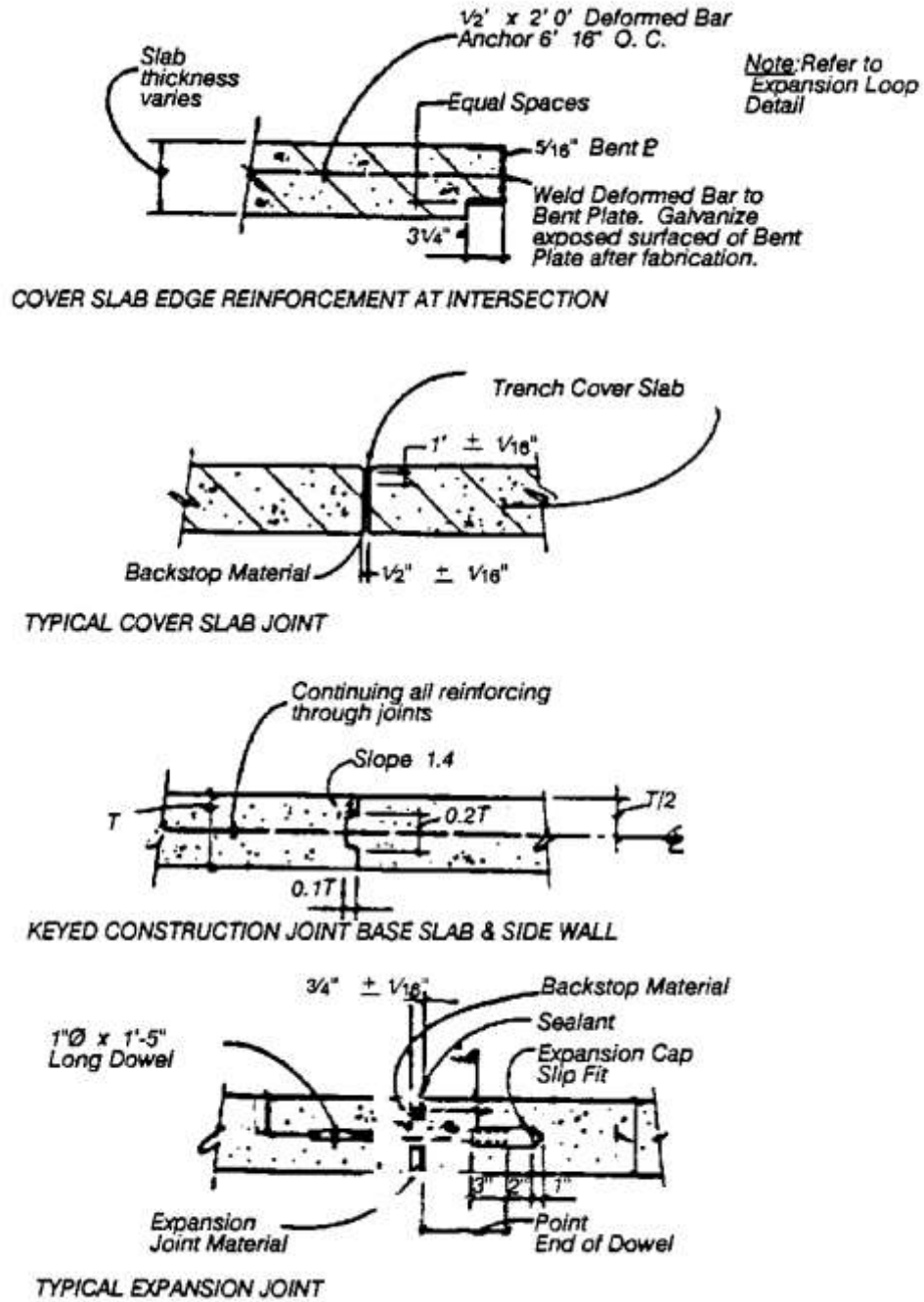

Figure 13

Concrete shallow trench heat distribution system, Detail 4

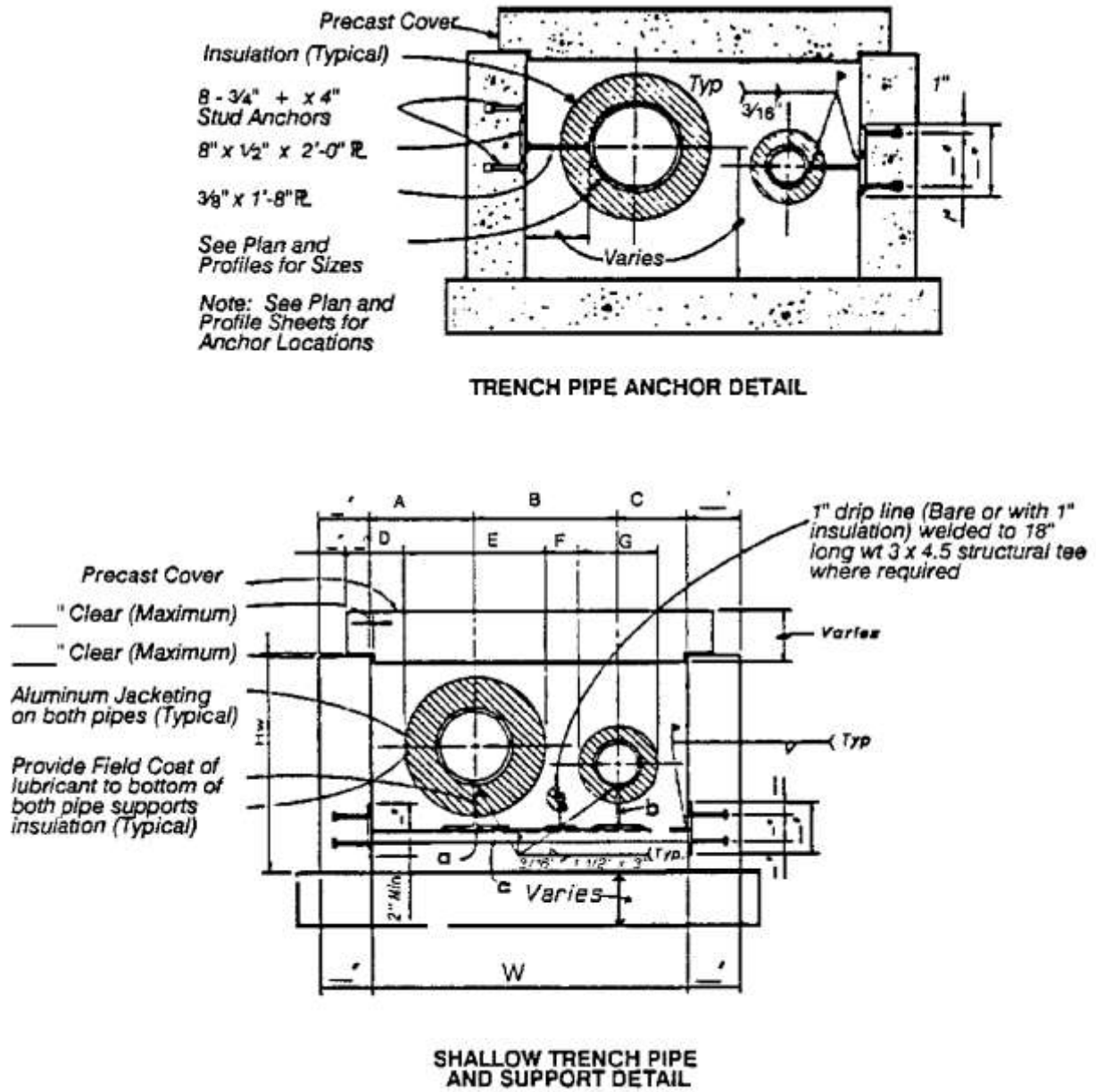

Figure 14

Concrete shallow trench heat distribution system, Detail 5

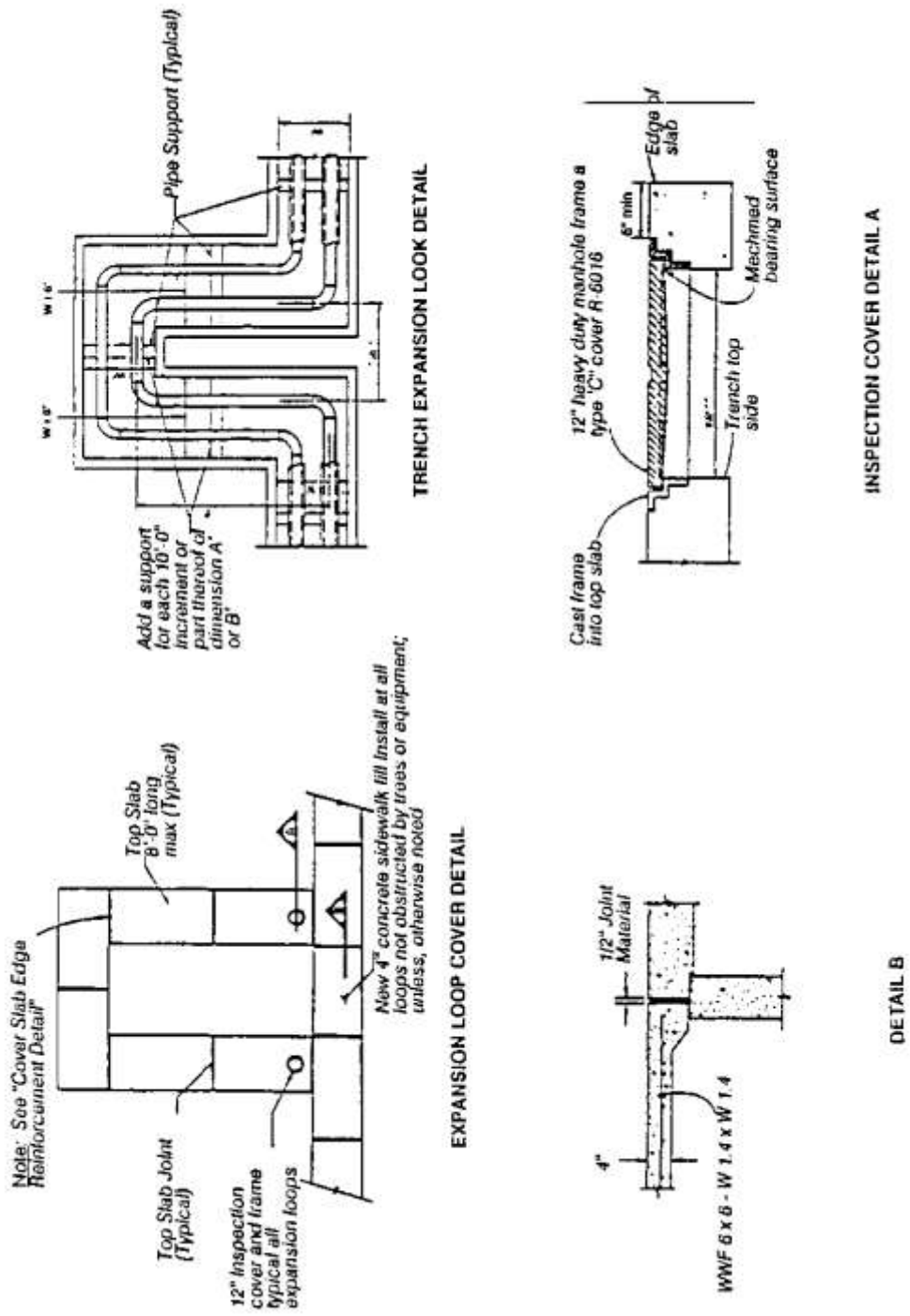

Figure 15

Concrete shallow trench heat distribution system, Detail 6



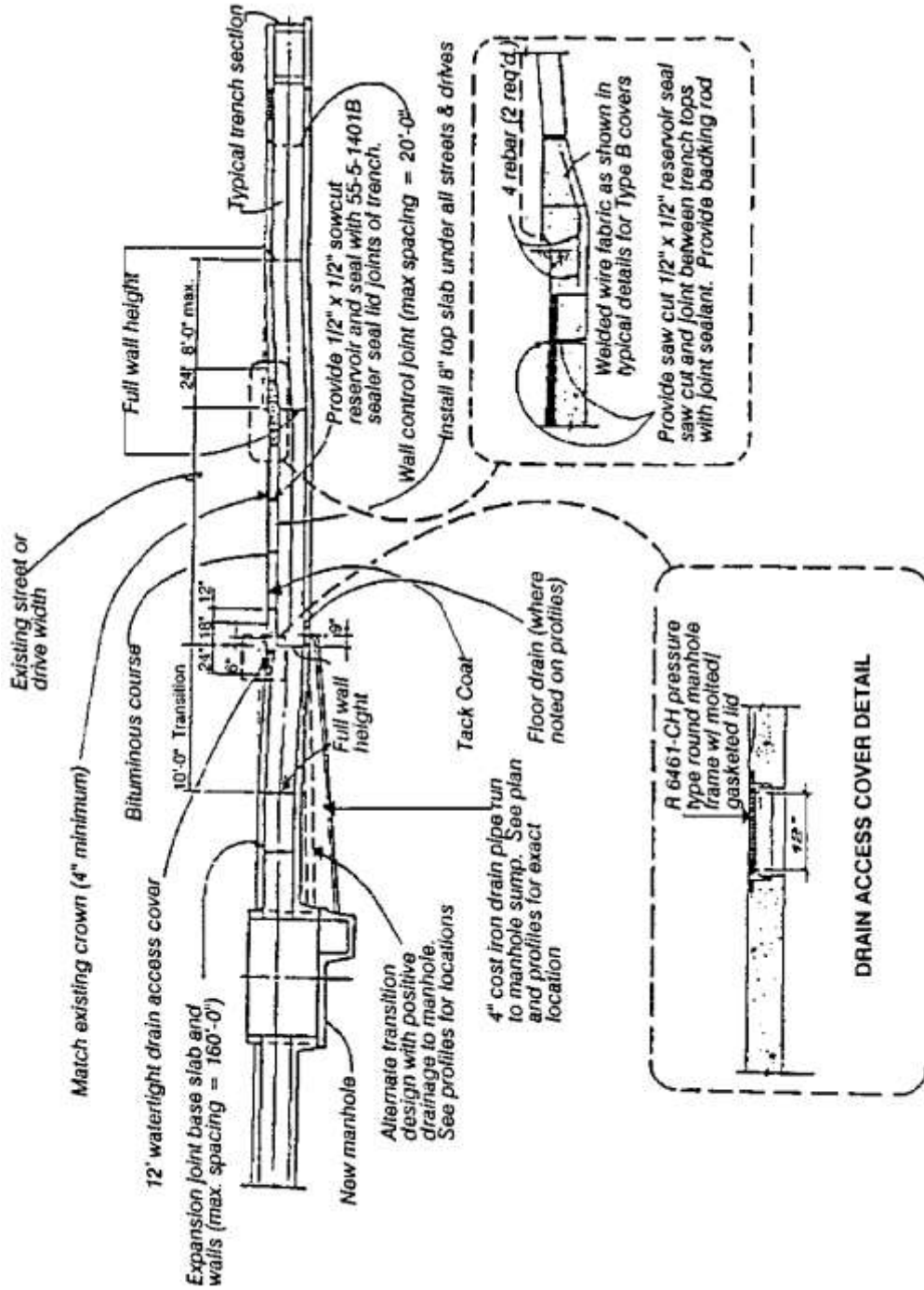
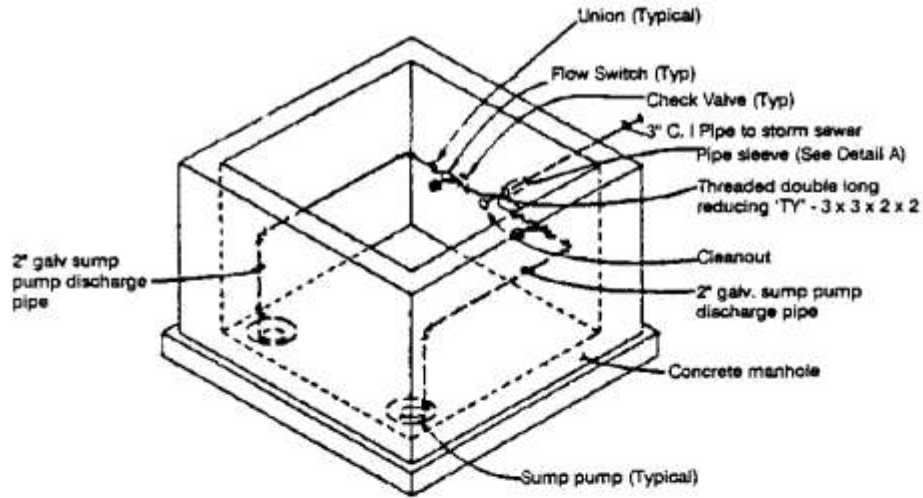

Figure 17

Concrete shallow trench heat distribution system, Detail 8



TYPICAL SUMP PUMP PIPING TO STORM SEWER

Note: Provide 1 (one) high water level alarm float switch per every two sump pumps in each manhole

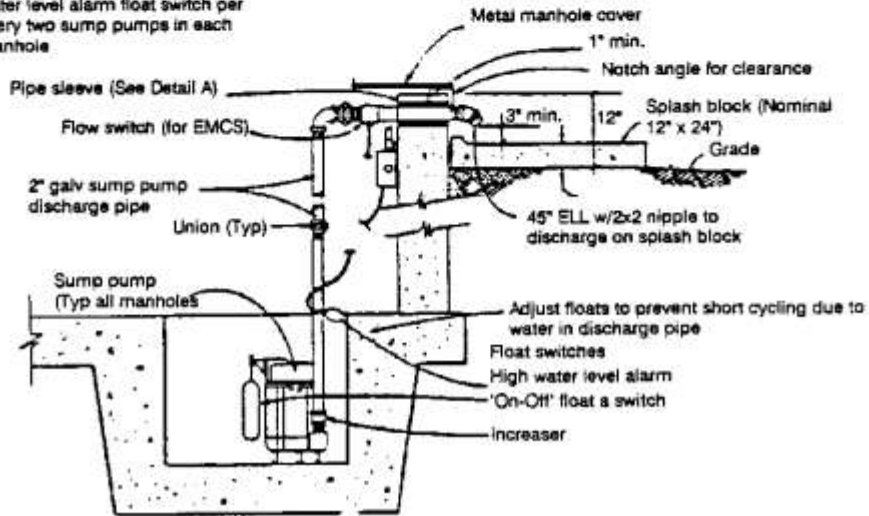

TYPICAL SUMP PUMP PIPING TO SPLASH BLOCK

Figure 18

Concrete shallow trench heat distribution system, Detail 9



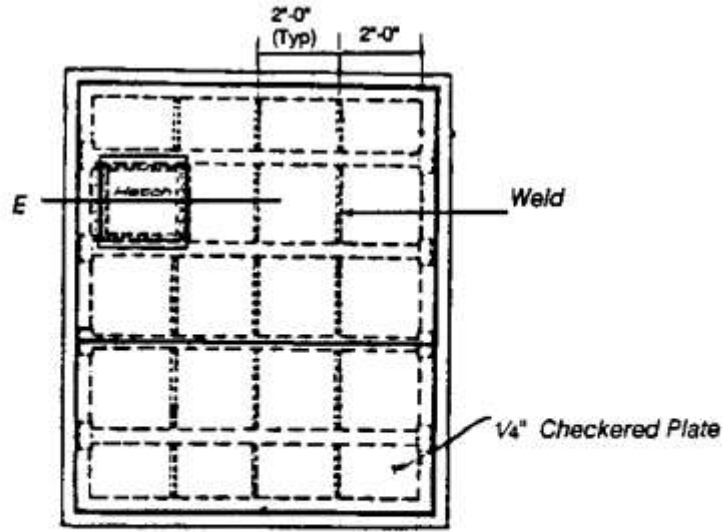

Plan

TYPICAL VALVE MANHOLE COVER IN WALKS

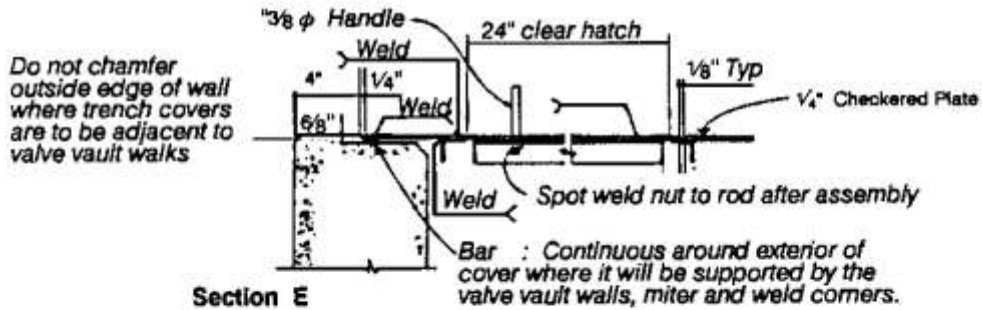

Section E

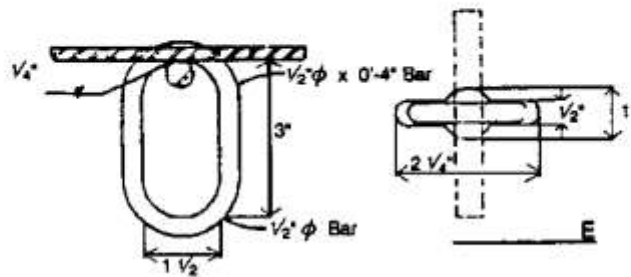

Section E

TYPICAL LIFTING DEVICE FOR VALVE MANHOLE COVER IN WALKS

Figure 20

Concrete shallow trench heat distribution system, Detail 11



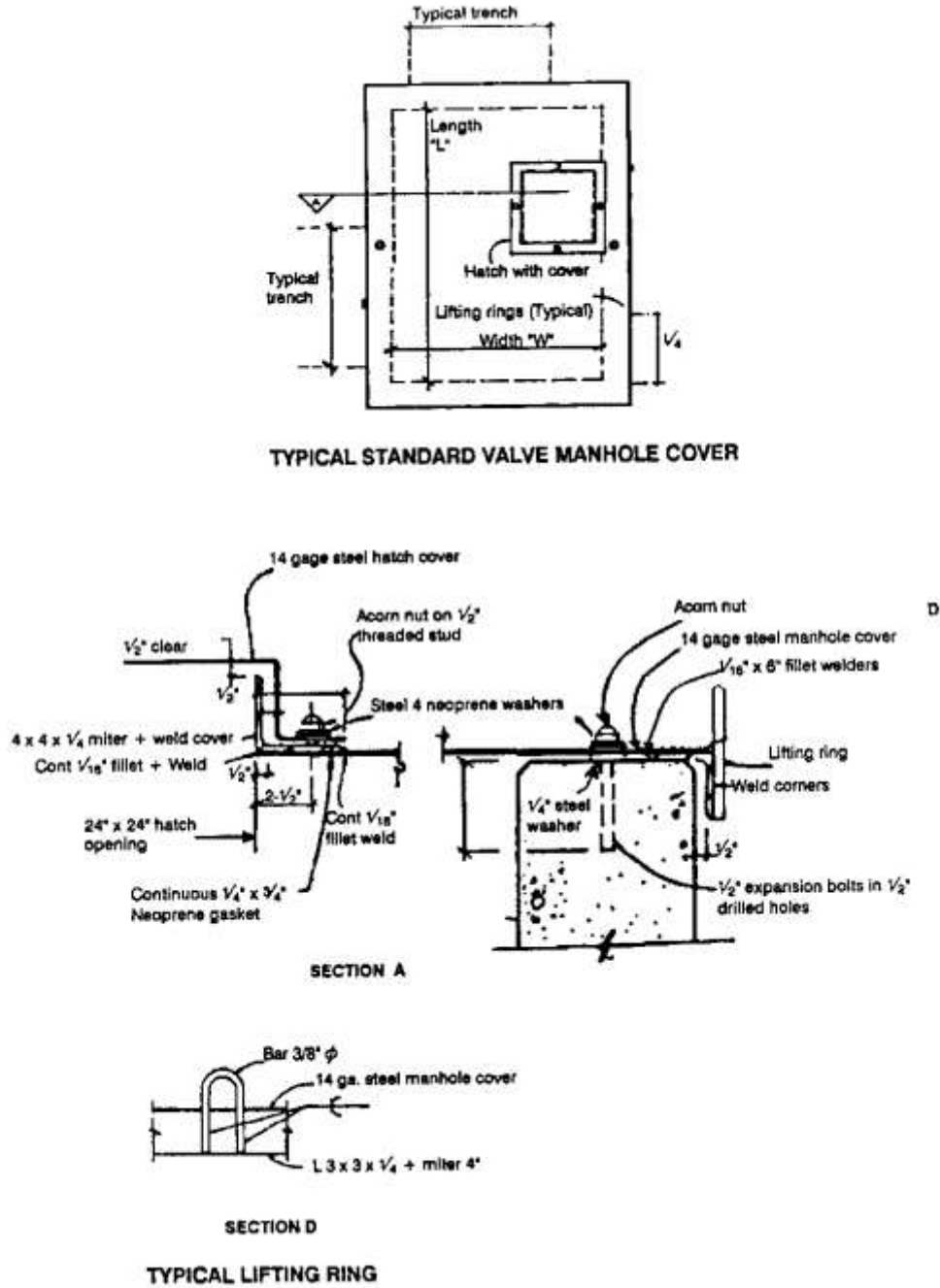

Figure 21

Concrete shallow trench heat distribution system, Detail 12

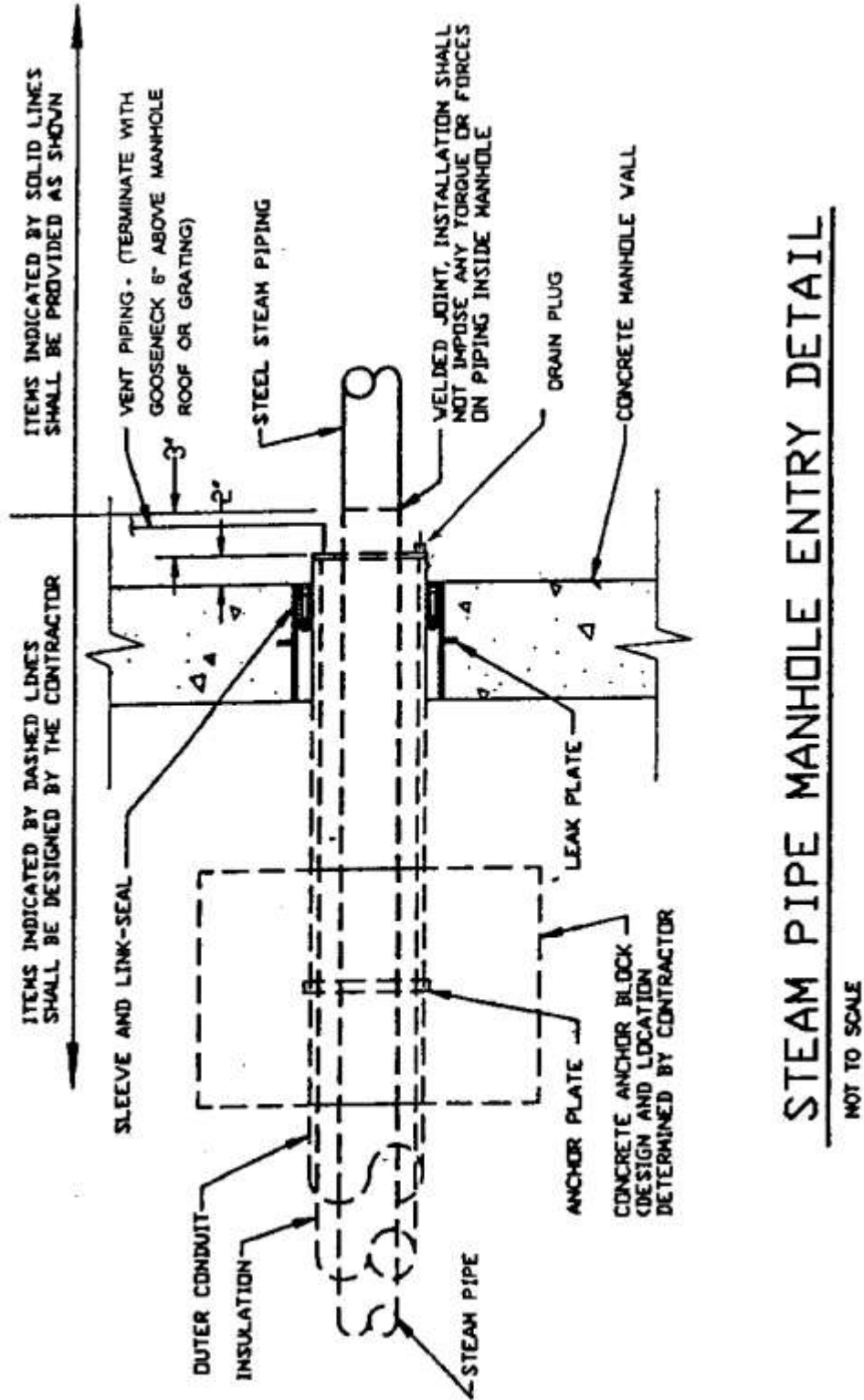

Figure 22

Concrete shallow trench heat distribution system, Detail 13