



**PDHonline Course R133 (2 PDH)**

---

# **Ethical Issues from the Kansas City Hyatt Hotel Collapse**

*Instructor: J. Paul Guyer, P.E., R.A., Fellow ASCE, Fellow AEI*

**2020**

**PDH Online | PDH Center**

5272 Meadow Estates Drive  
Fairfax, VA 22030-6658  
Phone: 703-988-0088  
[www.PDHonline.com](http://www.PDHonline.com)

An Approved Continuing Education Provider

## 1. INTRODUCTION

In July 1981 the most disastrous structural engineering failure in U.S. history took place in Kansas City. Two interior walkways in the lobby atrium collapsed at the recently constructed Hyatt Regency Hotel in Kansas City, with a resulting loss of 114 lives and injuries to 200 others. This is the story of that tragic event.

Here is what we will talk about ....

- **History of the project**
- **The structural failure**
- **The post-mortem**

And here are issues we will address....

- **Was the disaster preventable?**
- **Were the post-mortem conclusions appropriate?**
- **Were the actions of the profession appropriate?**
- **Would conclusions be different if the failure occurred today?**
- **How do we prevent similar events in the future?**



Figure 1  
Kansas City, Missouri



Figure 2  
The Hyatt Regency Hotel in Kansas City



Figure 3  
The Atrium Lobby



Figure 4  
The Atrium Lobby



Figure 5  
Suspended Walkways at the Atrium Lobby

## 2. HISTORY OF THE PROJECT

**2.1 THE OWNER.** In 1976 the Crown Center Corporation (Crown), a wholly owned subsidiary of Hallmark cards, undertook to develop a major hotel in Kansas City.

**2.2 THE OPERATOR.** Crown entered into an agreement with the Hyatt Hotels (Hyatt) organization to operate the hotel. Hyatt may or may not have had a management/ advisory role in the design and construction of the hotel, and may or may not have had influence on the project budget.

**2.3 THE ARCHITECT.** Crown hired an architect, PBDML Architects, Planners, Inc. (PBDML) as the prime contractor responsible for all aspects of the building design. PBDML's fee was \$1,650,000 (approximately \$6,100,000 in 2009 dollars).

**2.4 THE STRUCTURAL ENGINEER.** PBNMML hired Gillum-Colaco, Inc. (GCI) as consulting structural engineer. GCI's fee was \$247,000 (approximately \$921,000 in 2009 dollars).

**2.4.1 THE STRUCTURAL ENGINEER'S SUB-CONTRACTOR.** GCI sub-contracted the structural engineering work to an affiliated firm, Jack D. Gillum & Associates (Gillum) for an unknown fee. Gillum prepared approximately 60 drawings for the structural design of the project.

**2.5 THE CONTRACTOR.** Design of the project began in 1976. Design was substantively complete by 1978 and Eldridge Construction Company (Eldridge) was awarded the construction contract for the project 1978 on the basis of competitive bidding.

**2.6 THE STEEL FABRICATION/ERECTION SUB-CONTRACTOR.** Havens Steel Company (Havens) was awarded a sub-contract to fabricate and erect the structural steel for the project. Havens' contract was for \$390,000 (approximately \$1,450,000 in 2009 dollars). Havens obtained this sub-contract based on competitive bidding. Havens held itself out to its customers as providing engineering services, as well as fabrication and erection services.

**2.7 THE STEEL DETAILER.** Havens sub-contracted the structural steel detailing work to WRW, a company having an experienced registered professional engineer as a principal. WRW prepared over 40 structural drawings for design of the project.

**2.8 THE INSPECTION FIRM.** Crown hired an inspection firm H&R Inspection General Testing (General Testing) to assure the quality of the construction work and its conformance with the working drawings and specifications. General Testing had a registered professional engineer in its employ.

## **2.9 SOME KEY EVENTS**

**2.9.1 STRUCTURAL ENGINEER'S RECOMMENDATION FOR FULL-TIME JOB-SITE REPRESENTATIVE DENIED.** On three occasions Gillum requested funding to have a full-time project quality control representative on the job-site, but these funding requests were not approved by Crown.

**2.9.2 SPECIFICATIONS WERE PREPARED BY ARCHITECT.** The specifications for the project were prepared by PBNMML, not Gillum. Structural aspects of those specifications were "reviewed and commented upon" by Gillum.

**2.9.3 EARLIER ATRIUM ROOF COLLAPSE.** This tragic incident was preceded by an earlier structural failure on the same project. On Sunday, October 14, 1979, while the hotel was still under construction, a portion of the atrium ceiling structure collapsed. Because the collapse occurred on a weekend, there were no workers present and there were no injuries or fatalities.

Crown retained an independent structural engineering firm, Seiden Page, to investigate the cause of the roof collapse. Seiden Page identified the cause of the collapse, and design changes were made by Gillum. Seiden Page was not retained to investigate the adequacy of any other structural features of the building design such as the atrium walkways.

### **3. THE STRUCTURAL FAILURE**

Construction was completed and the hotel opened for business in July 1980.

In July 1981 about 1500 people were attending a major social event at the hotel....a weekly dance contest held in and around the atrium lobby. Large numbers of people were dancing and socializing on the three suspended walkways that traversed the atrium lobby space.

The structural failure occurred at two of the three suspended walkways that traversed from one side to the other of the atrium lobby. Walkways that failed were directly in line with each other and crossed from one side to the other at the second and fourth floors.

The third walkway, at the third floor, was offset from the other two and was not involved in the failure.

The fourth floor walkway failed, collapsed onto the second floor walkway, both crashed to the lobby floor, and 114 people were killed and 200 injured.

The rescue effort provided by first-responders in the Kansas City area appears to have been prompt and effective. A convention of radiologists happened to have been meeting in the hotel at the time of the collapse, and they provided important medical assistance to the injured at the scene.

Here is what the incident scene looked like....



Figure 6





Figure 7



Figure 8

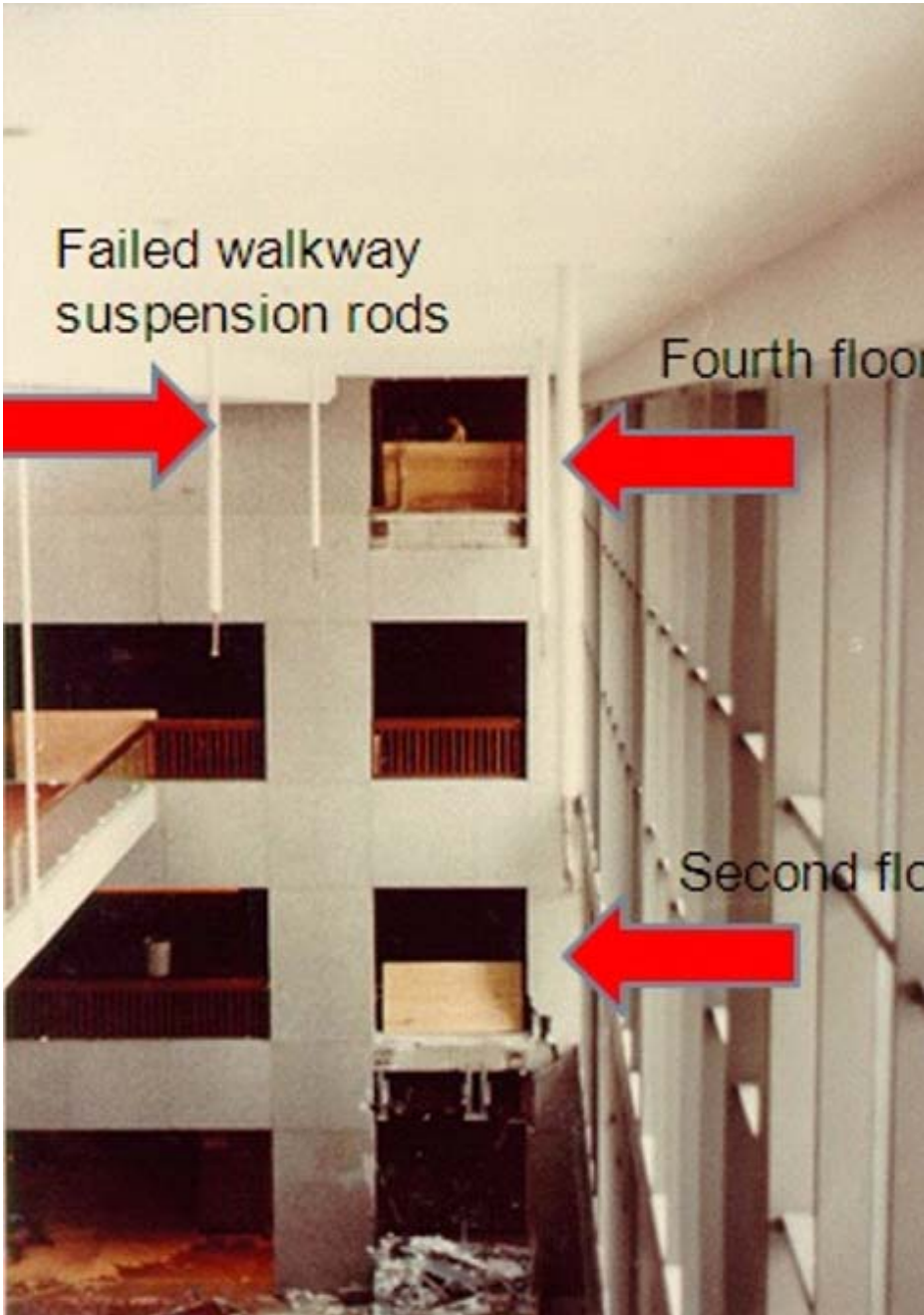

Figure 9  
Collapsed Walkways at 2<sup>nd</sup> and 4<sup>th</sup> Floors

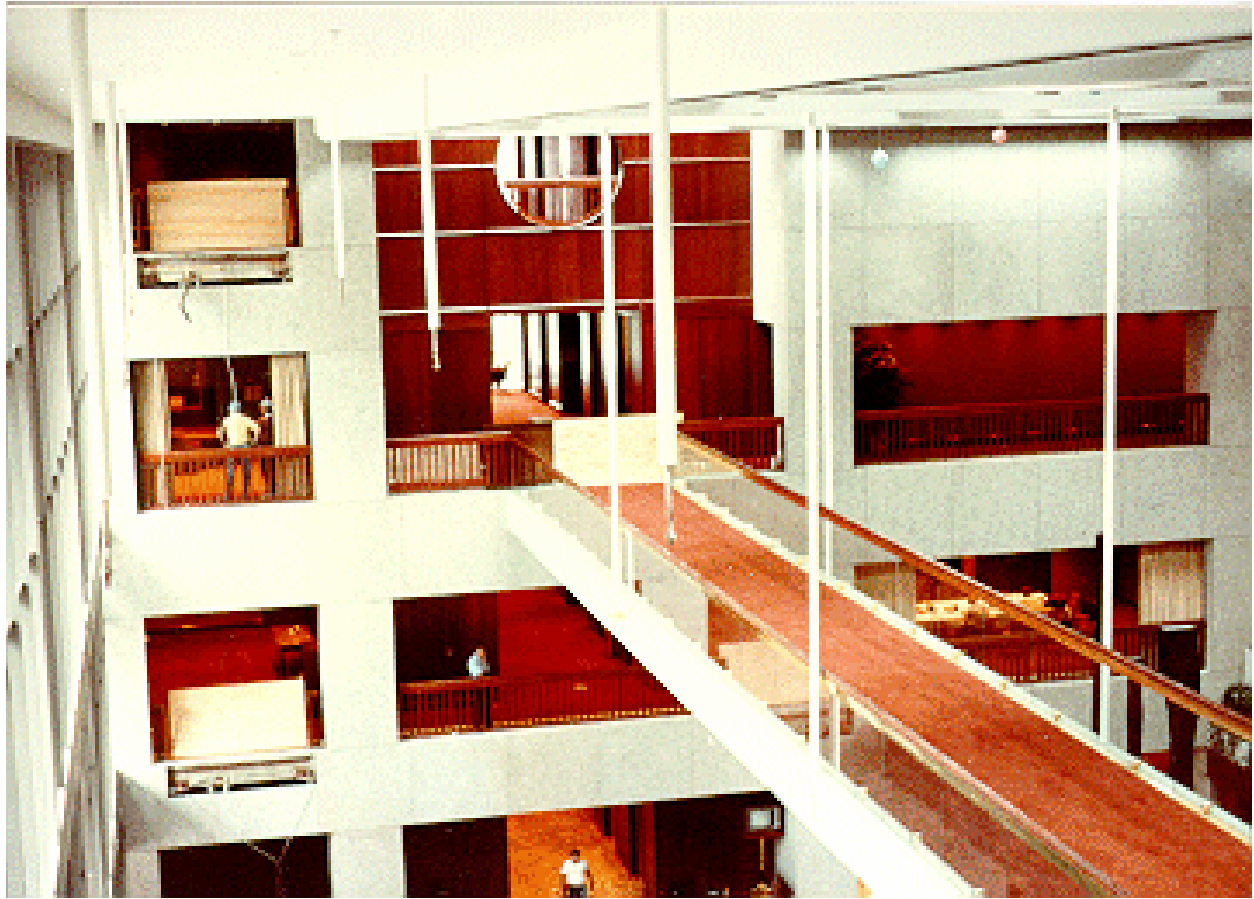

Figure 10  
Surviving 3<sup>rd</sup> Floor Walkway

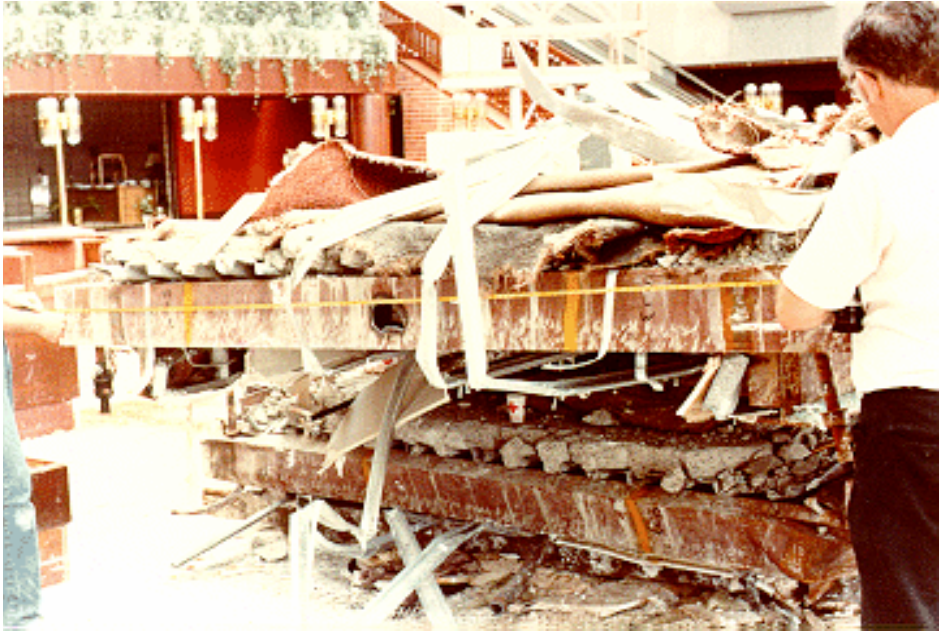

Figure 11



Figure 12

#### **4. WHAT WENT WRONG?**

**4.1 CAUSE OF THE FAILURE.** One theory suggested at an early stage was that the people dancing on the fourth floor walkway induced harmonic vibrations that reached critical amplitude that resulted in failure. This theory was disregarded when evidence of a different cause became apparent.

The cause of the failure was a change made by the steel detailer (WRW, a sub-contractor to Havens, which in turn was a sub-contractor to Eldridge) to the suspension rods design shown on the structural engineer Gillum's drawings.

**4.2 THE IMPETUS FOR THE DESIGN CHANGE.** Why did WRW, at Haven's instigation, make this change? Because of two *constructability* issues....

**First**, the Gillum design required continuous suspension rods approximately 40-feet long. Havens determined these would be unacceptably expensive to procure and install.

**Second**, the suspension rods would have to be threaded for approximately 30-feet of their length in order to install the nut on the rod that supported the fourth floor walkway. This was determined by Havens to be unacceptably expensive to fabricate and install.

**4.3 THE CHANGE.** This is the change WRW/Havens made to Gillum's design....

1-1/4" continuous suspension rod from 4<sup>th</sup> floor atrium ceiling, through 4<sup>th</sup> floor walkway, to 2<sup>nd</sup> floor walkway

4<sup>th</sup> floor walkway deck structure (connection similar at 2<sup>nd</sup> floor walkway)

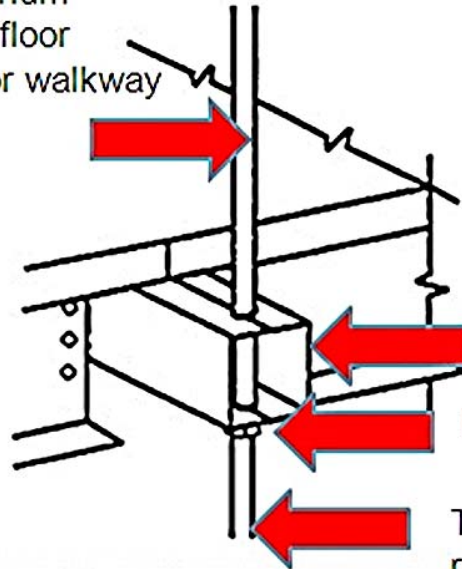

Box beam fabricated of two 8x8.5 MC channels welded toe-to-toe

Box beam rests on nut

Threading of rod required from 2<sup>nd</sup> to 4<sup>th</sup> floor walkways

Gillum's design

Figure 13  
The Structural Engineer's Original Design

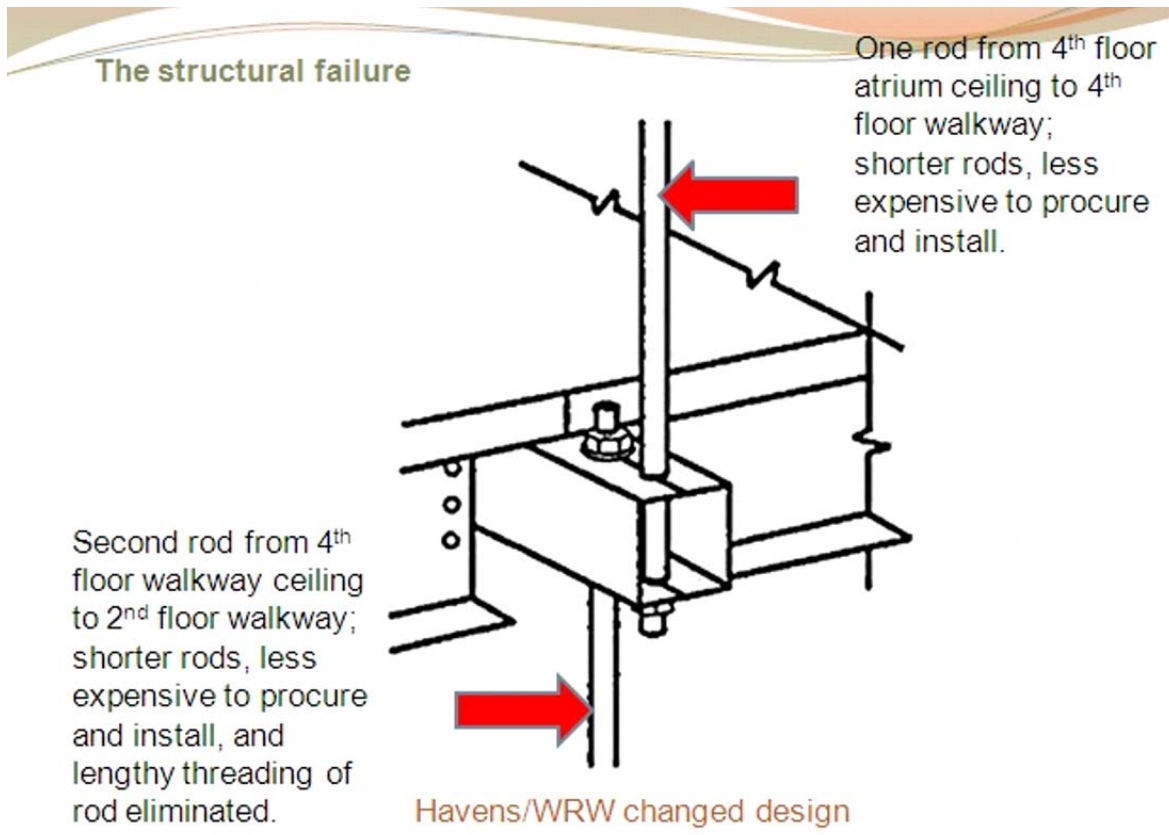
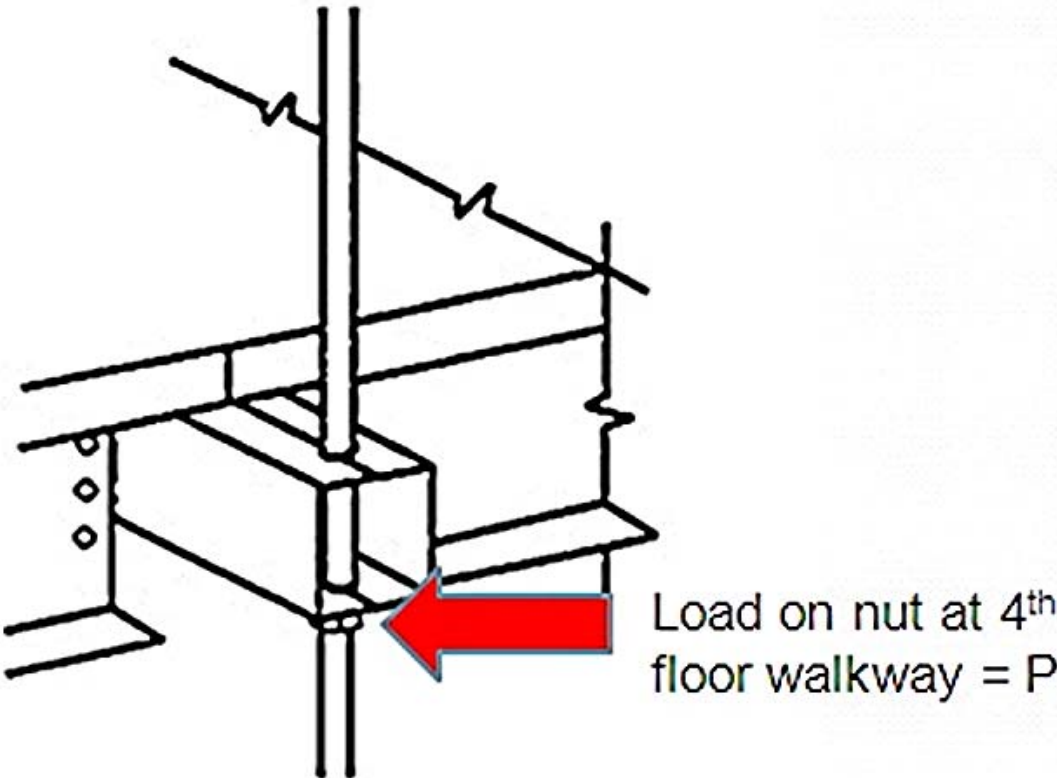

Figure 14  
The change made by the Steel Fabricator-Erector/Detailer



Gillum's design

Figure 15  
The Structural Engineer's Original Design



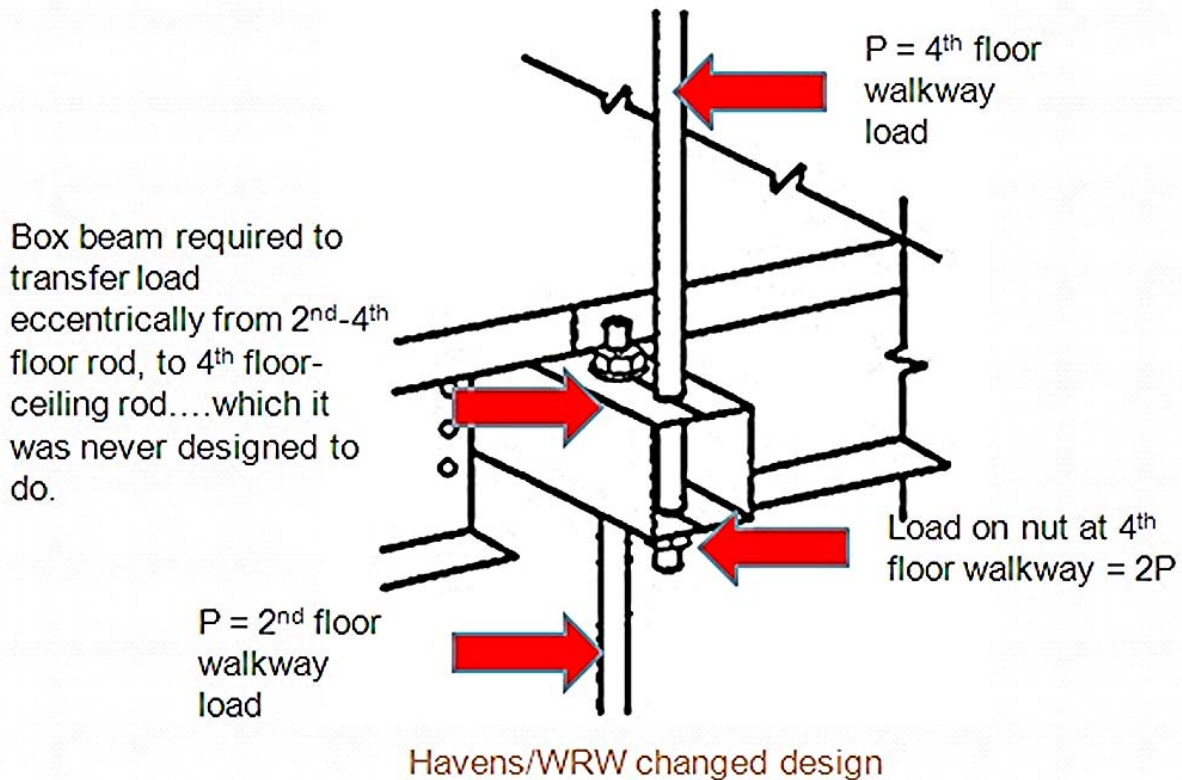

Figure 16  
The change made by the Steel Fabricator-Erector/Detailer

#### 4.4 ADDITIONAL CONSIDERATIONS

And there were two additional considerations noted in the subsequent investigations:

**4.4.1 SUSPENSION RODS UNDERSIZED.** Gillum's original design sized the suspension rods such that they were strong enough to support only 60% of the imposed load...based on code-allowable stresses. But given the difference between code-allowable and yield stresses of the materials...was this a fatal error? The investigations clearly indicated the failure occurred at the nuts and box beams, not at the rods.

**4.4.2 ABSENCE OF REDUNDANT SUSPENSION RODS.** Clearly the use of redundant suspension rods may have prevented the tragedy. But by definition

redundant elements are not needed in the basic design of a connection, but are typically called for only when there is uncertainty about loads, materials, etc.

#### 4.5 AND HERE IS WHAT HAPPENED....



Figure 17



Figure 18

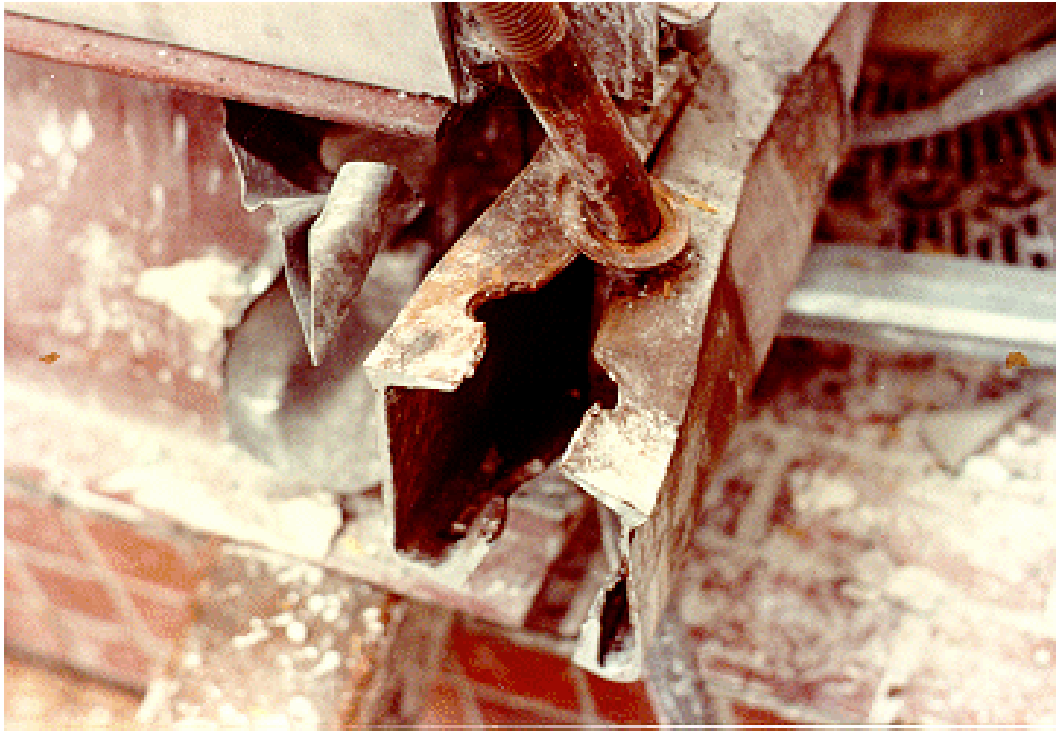

Figure 19



Figure 20

## 5. THE POST-MORTEM

### 5.1 AND NOW BEGINS THE FINGER-POINTING....

- Havens said it notified Gillum of the change by telephone.
- Gillum denies having received any such telephone call.
- Havens submitted over 40 steel fabrication drawings to Gillum for review. Included on one of these drawings was the fatal change.
- Gillum reviewed and returned the drawings stamped “Reviewed only for conformance with the design concept and for compliance with the information given in the contract documents.”
- Havens proceeded to fabricate and erect the structural steel for the project in accordance with the fabrication drawings.
- Several participants in the design-construction process purported to have told Gillum of concerns that they had about the safety of the proposed change, including: the construction detailer (WRW), the steel fabricator (Havens), the architect (PBDML), and a technician. Is there anything interesting about these allegations?

**5.2 THE NBS INVESTIGATION.** The National Bureau Standards (today, the National Institute of Standards and Technology) was the lead agency in the technical

investigation following the collapse. NBS determined essentially that the failure was due to:

- **the design change which led to the failure at the box beam-nut-suspension rod connection**

and was contributed to by:

- failure to design the suspension rods to code-approved stresses
- failure to provide redundant suspension rods

THE NBS specifically concluded that “Under the original hanger rod arrangement (continuous rod) the box beam-hanger rod connections as shown on the contract drawings *would have had the capacity to resist the loads estimated to have been acting at the time of collapse.*”

**5.2.1 INDUSTRY PRACTICE.** As part of its investigation the NBS looked at the historical development of professional and trade practices in steel structure design and construction industry. This is what it found....

**5.2.1.1 Prior to the Second World War** most steel structures were designed using rivets and the structural engineer designed and detailed all connections (sized members and rivets, detailed rivet patterns and all other aspects of the connections), and provided all of these details on the structural drawings. Construction contractors then constructed the structure in strict accordance with the working drawings.

**5.2.1.2 After the Second World War other connection types were developed** such as bolted and welded.

**5.2.1.3 In response to this changed environment,** steel fabricators and erectors developed their own preferences for connection details and began to make a case that they should be allowed to design connection details to suit their preferences.

**5.2.1.4 Out of this environment, the American Institute of Steel Construction (AISC) developed a handbook of steel connection details** that could be used by steel fabrication and erection companies to select straight-forward connection details, based on loads specified by the structural engineer. Given the economic pressures under which structural engineers operated, they were largely comfortable in surrendering this connection detailing responsibility to fabricators/erectors on “standard” connections.

**5.2.1.5 Thus, the contemporary practice developed** whereby the steel fabricator/erector prepared connection details for standard connections utilizing the AISC manual, and the structural engineer detailed only non-standard details on his drawings.

**5.2.1.6 In this case,** the suspension rod/walkway deck connection was not a standard connection, and it was detailed by the structural engineer Gillum on his working drawings.

**5.3 THE MISSOURI REGISTRATION BOARD.** The Missouri registration board (Missouri Board) “convicted” (a questionable term, given that this was an administrative, not criminal, sanction) Gillum and a professional engineer in his employ of:

- Gross negligence
- Misconduct
- Unprofessional conduct in the practice of engineering

and cancelled their Missouri professional engineering registrations.

**5.4 CIVIL DAMAGES.** Major civil damage claims were paid to victims and their estates through judgments and settlements, primarily by the owner, Crown and its insurers....as the clear deep-pockets in the event.

## **6. WAS THE DISASTER PREVENTABLE?**

## **6.1 CLEARLY, YES, IF....**

**6.1.1** Havens/WRW had properly designed the changed detail

**6.1.2** The improperly changed detail had been noted and corrected by Gillum

## **6.2 OTHER ACTIONS** that may have prevented the collapse were....

**6.2.1** if Gillum had provided redundant suspension rods in its design

**6.2.2** if Gillum had sized the suspension rods in accordance with code-approved stresses (although the failure was the nut, not the rod)

## **7. WERE THE POST-MORTEM CONCLUSIONS APPROPRIATE?**

**7.1 The post-mortem effectively placed all of the blame on the structural engineer of record, Gillum.** But this raises questions....

**7.2 What is the responsibility of Havens,** which held itself out to its customers as providing engineering services, in addition to fabrication and erection services, and instigated the change for economic reasons?

**7.3 What is the responsibility of WRW,** which designed the change under the direction of its registered professional engineer?

**7.4 What is the responsibility of the architect PBDML** which held itself out to its customers as being the master designer responsible for all aspects of the design?

**7.5 What is the responsibility of Eldridge,** which held itself out as responsible for all construction, including that of its sub-contractors Havens and WRW?

**7.6 What is the responsibility of the owner, Crown,** which did not fund additional structural engineering review by Seiden Page after the earlier atrium roof collapse, and after Gillum recommended and requested funding for a full-time representative at the job site?



## **8. WERE THE ACTIONS OF THE PROFESSION APPROPRIATE?**

Although certainly morally defensible, is ASCE's position that "the structural engineer" is responsible for all aspects of the structural design *practicable* in light of the fact that....

**8.1 there are other members of the design-construct team who affect the structural design and construction**, and they are often outside the control of "the structural engineer,"

**8.2 and there are very significant economic pressures** under which "the structural engineer" and other members of the design-construct team must operate on typical projects.

Similarly, although NSPE's Canon No. 1 expresses a laudable ideal....is it practicable, and does it provide any useful guidance in the "real world?"

## **9. WOULD CONCLUSIONS BE DIFFERENT IF THE FAILURE OCCURRED TODAY?**

This incident occurred over 25 years ago.

**9.1 Have there been changes in the building design and construction industry** that would lead to different conclusions if the incident occurred today?

**9.2 Specifically, what should be the responsibilities under a "design-build" construction delivery process** where a construction contractor holds itself out to its customers as qualified to design as well as construct buildings?

## **10. HOW DO WE PREVENT SIMILAR EVENTS IN THE FUTURE?**

Here are some realities....

**10.1 The building design and construction process is highly complex.** It is not only technically complex, it is organizationally complex. It involves many people with different capabilities, motivation levels and economic objectives.

**10.2 People always make mistakes.** It is human nature to make mistakes. Any process where people are involved needs to recognize this.

**10.3 Economic pressures are very powerful forces in the building design and construction process.** All of the members of the building design and construction team are under enormous economic pressures. Most if not all obtained their work through price competition.... competitive bidding.

**10.4 It is axiomatic that someone cannot be held responsible for achieving an objective, without commensurate authority**.... and in building design and construction an essential part of that authority is *budget authority*. It is also axiomatic, however, that owners will *never* give up budget authority to anyone.

**10.5 Although all members of the design and construction team do not have the same level of expertise, all *do* have some level of expertise.** Therefore, take advantage of this. *Force as many sets of eyes as possible to look at the drawings!*

In light of these realities, avoidance of tragic incidents such as this on future projects requires a *strategy* that forces as many knowledgeable members of the design and construction team to participate in and take some degree of responsibility for design and construction decisions as possible.

**10.6 The cause of this tragedy was an ineffective change management system.**

To prevent this type of tragedy in the future, three things are needed:

- A CLEARLY DEFINED ORGANIZATIONAL STRUCTURE**
- CLEARLY DEFINED AND ENFORCED PROCESS PROCEDURES**
- INDEPENDENT CONSTRUCTABILITY REVIEW**

**11. ORGANIZATIONAL STRUCTURE AND PROCEDURES:** Here is what the design and construction organizational structure and decision-making process should look like....

Example: Organizational Structure and Design/Change Management Process

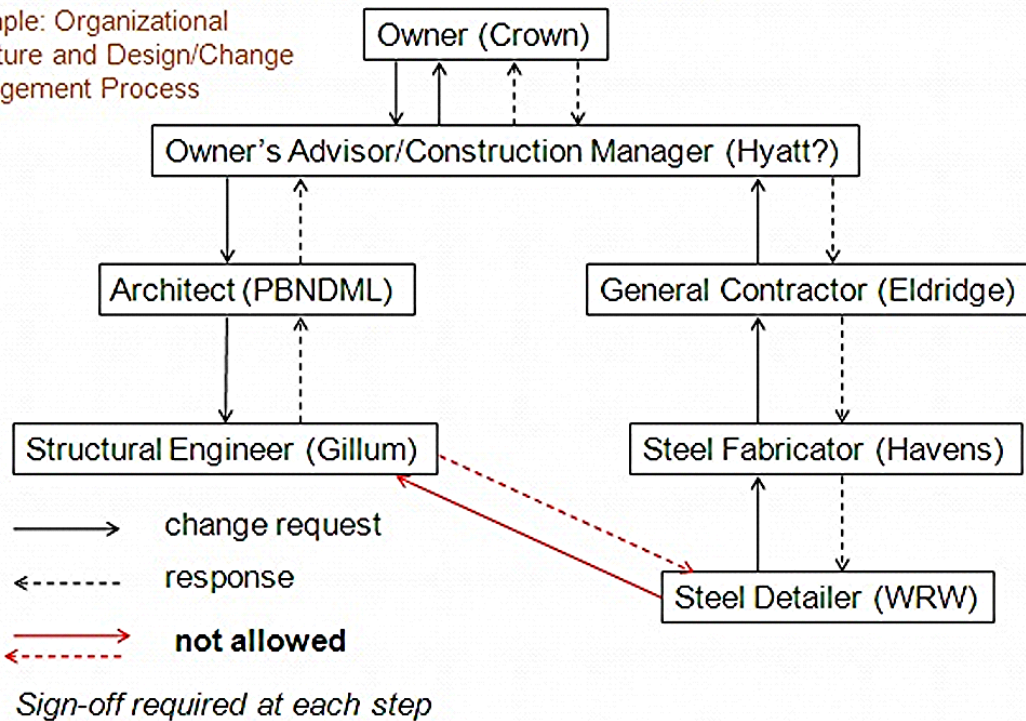

**11.1 IS THIS STRUCTURE/PROCEDURE INEFFICIENT?** No. Here is why....

**11.1.1 It forces as many “sets of eyes” as possible to look at contract documents** (drawings, specifications, changes).

**11.1.2 Although team members have different levels of expertise, all have *some* level of expertise**, and therefore can potentially spot errors and questionable actions.

**11.1.3 The requirement for “sign-off” at each level forces team members to *take things seriously*** and accept some level of responsibility.

**11.1.4 The owner's participation in this process is essential** *because only the owner has budget authority.*

**11.1.5 There are well accepted methodologies where time is critical** to issue directives with post-facto sign offs.

**12. CONSTRUCTABILITY REVIEW.** And here is a very important component of the design and construction process on any substantive project...a *constructability review*, ideally coupled with a *value engineering review*.

**12.1 A *constructability review* is** an advisory review of the 100% working drawings and specifications by an independent team of experienced design and construction professionals intended to identify features indicated by the working drawings and specifications that are impractical, unsafe or that can be accomplished in a more cost effective manner. The abnormally long, threaded suspension rods indicated by the original design for this project are the type of feature a *constructability review* could be expected to identify, which would have allowed the structural engineer to develop a more practicable solution that would have prevented the design change made by the steel detailer/fabricator WRW/Havens.

**12.2 A *value engineering review* is** an advisory review of the 100% working drawings and specifications by an independent team of experienced design and construction professionals intended to develop cost savings by proposing more cost effective design features and details.

A *constructability review* and a *value engineering review* both add moderate cost to a design budget, but if they are proposed as a teamed undertaking, an owner can often be convinced to provide the additional funding required because of the real probability that more than enough construction savings can be realized that will offset the additional cost of the reviews.

To repeat...to prevent this type of tragedy on future projects:

- FORCE AS MANY SETS OF EYES AS POSSIBLE TO LOOK AT THE DRAWINGS AND SPECIFICATIONS**
  
- FORCE TEAM MEMBERS TO TAKE THINGS SERIOUSLY BY REQUIRING SIGN-OFF ON EVERY SUBSTANTIVE DECISION AND ACTION.**
  
- CONVINCE THE OWNER TO FUND AN INDEPENDENT *CONSTRUCTABILITY REVIEW*.**

### **13. ONE GOOD THING CAME OUT OF THIS....**

An issue was raised to the effect that the Kansas City building department was said to be overworked and did not adequately check the structural drawings and calculations, and might thereby have discovered the fatal defect.

The one positive outcome of this event was a heightened awareness nationwide of the importance of the building department plan checking activity. This generally resulted in better funding and more rigorous plan checking in building departments throughout the country.