



PDHonline Course R133V (1 PDH)

Ethical Issues from the Kansas City Hyatt Hotel Collapse (Video Course)

Instructor: J. Paul Guyer, P.E., R.A., Fellow ASCE, Fellow AEI

2020

PDH Online | PDH Center

5272 Meadow Estates Drive
Fairfax, VA 22030-6658
Phone: 703-988-0088
www.PDHonline.com

An Approved Continuing Education Provider

ETHICAL ISSUES FROM THE KANSAS CITY HYATT HOTEL COLLAPSE

Paul Guyer, P.E., R.A.

© Paul Guyer 2010 1

In July 1981 the most disastrous structural engineering failure in U.S. history took place in Kansas City. Two interior walkways in the lobby atrium collapsed at the recently constructed Hyatt Regency Hotel in Kansas City, with a resulting loss of 114 lives and injuries to 200 others. This is the story of that tragic event.

© Paul Guyer 2010 2

Paul Guyer, P.E., R.A.

Paul Guyer is a registered Civil Engineer, Mechanical Engineer, Fire Protection Engineer and Architect with 35 years experience designing buildings and related infrastructure. For an additional 9 years he was a principal staff advisor to the California Legislature on infrastructure and capital outlay issues. He is a graduate of Stanford University and a Fellow of the American Society of Civil Engineers and the Architectural Engineering Institute.

© Paul Guyer 2010 3

Here is what we will talk about today....

- History of the project
- The structural failure
- The post-mortem

And here are issues we will address....

- Was the disaster preventable?
- Were the post-mortem conclusions appropriate?
- Were the actions of the profession appropriate?
- Would conclusions be different if the failure occurred today?
- How do we prevent similar events in the future?

© Paul Guyer 2010 4

Kansas City, Missouri



© Paul Guyer 2010 5

The Hyatt Regency Hotel in Kansas City



© Paul Guyer 2010 6

The Hyatt Regency Hotel in Kansas City – the Atrium Lobby today



© Paul Guyer 2010

7

The Hyatt Regency Hotel in Kansas City – the Atrium Lobby today



© Paul Guyer 2010

8

The Hyatt Regency Hotel in Kansas City – the Atrium Lobby before 1981

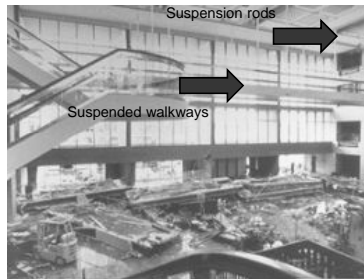

© Paul Guyer 2010

9

History of the project

- In 1976 the Crown Center Corporation (Crown), a wholly owned subsidiary of Hallmark cards, undertook to develop a major hotel in Kansas City. Crown entered into an agreement with the Hyatt Hotels (Hyatt) organization to operate the hotel.
- Hyatt may or may not have had a management/advisory role in the design and construction of the hotel, and may or may not have had influence on the project budget.
- Crown hired an architect, PBNMML Architects, Planners, Inc. (PBNMML) as the prime contractor responsible for all aspects of the building design. PBNMML's fee was \$1,650,000 (approximately \$6,100,000 in 2009 dollars).
- PBNMML hired Gillum-Colaco, Inc. (GCI) as consulting structural engineer. GCI's fee was \$247,000 (approximately \$921,000 in 2009 dollars).

© Paul Guyer 2010

10

History of the project

- GCI sub-contracted the structural engineering work to an affiliated firm, Jack D. Gillum & Associates (Gillum) for an unknown fee. Gillum prepared approximately 60 drawings for the structural design of the project.
- Design of the project began in 1976.
- Design was substantively complete by 1978 and Eldridge Construction Company (Eldridge) was awarded the construction contract for the project 1978 on the basis of competitive bidding.
- Havens Steel Company (Havens) was awarded a sub-contract to fabricate and erect the structural steel for the project. Havens' contract was for \$390,000 (approximately \$1,450,000 in 2009 dollars). Havens obtained this sub-contract based on competitive bidding. Havens held itself out to its customers as providing engineering services, as well as fabrication and erection services.

© Paul Guyer 2010

11

History of the project

- Havens sub-contracted the structural steel detailing work to WRW, a company having an experienced registered professional engineer as a principal. WRW prepared over 40 structural drawings for design of the project.
- Crown hired an inspection firm H&R Inspection General Testing (General Testing) to assure the quality of the construction work and its conformance with the working drawings and specifications. General Testing had a registered professional engineer in its employ.
- On three occasions Gillum requested funding to have a full-time project quality control representative on the job-site, but these funding requests were not approved by Crown.
- The specifications for the project were prepared by PBNMML, not Gillum. Structural aspects of those specifications were "reviewed and commented upon" by Gillum.

© Paul Guyer 2010

12

History of the project

□ This tragic incident was preceded by an earlier structural failure on the same project. On Sunday, October 14, 1979, while the hotel was still under construction, a portion of the atrium ceiling structure collapsed. Because the collapse occurred on a weekend, there were no workers present and there were no injuries or fatalities.

□ Crown retained an independent structural engineering firm, Seiden Page, to investigate the cause of the roof collapse. Seiden Page identified the cause of the collapse, and design changes were made by Gillum. Seiden Page was not retained to investigate the adequacy of any other structural features of the building design such as the atrium walkways.

© Paul Guyer 2010

13

The structural failure

□ Construction was completed and the hotel opened for business in July 1980.

□ In July 1981 about 1500 people were attending a major social event at the hotel...a weekly dance contest held in and around the atrium lobby. Large numbers of people were dancing and socializing on the three suspended walkways that traversed the atrium lobby space.

□ The structural failure occurred at two of the three suspended walkways that traversed from one side to the other of the atrium lobby. Walkways that failed were directly in line with each other and crossed from one side to the other at the second and fourth floors. The third walkway, at the third floor, was offset from the other two and was not involved in the failure.

© Paul Guyer 2010

14

The structural failure

□ The fourth floor walkway failed, collapsed onto the second floor walkway, both crashed to the lobby floor, and 114 people were killed and 200 injured.

□ The rescue effort provided by first-responders in the Kansas City area appears to have been prompt and effective. A convention of radiologists happened to have been meeting in the hotel at the time of the collapse, and they provided important medical assistance to the injured at the scene.

□ Here is what the incident scene looked like....

© Paul Guyer 2010

15

The structural failure



© Paul Guyer 2010

16

The structural failure



© Paul Guyer 2010

17

The structural failure

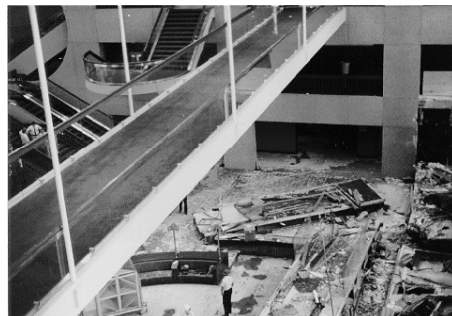

© Paul Guyer 2010

18

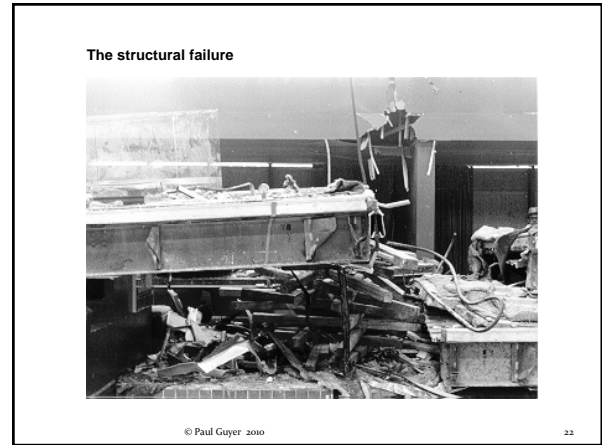
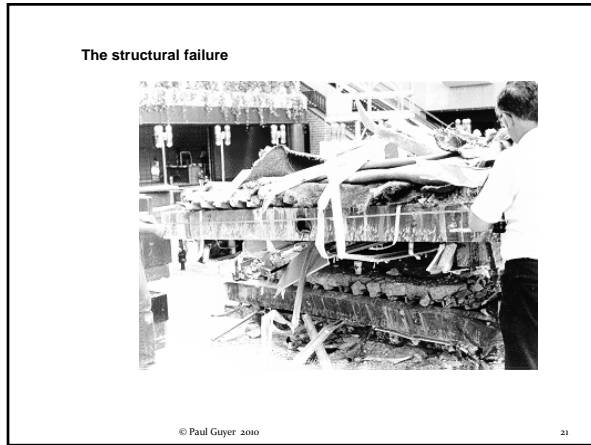
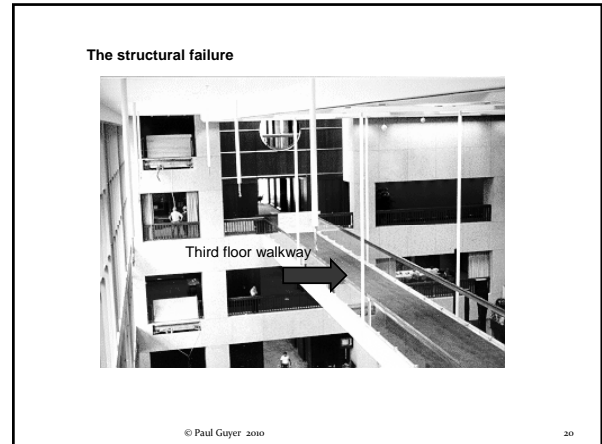
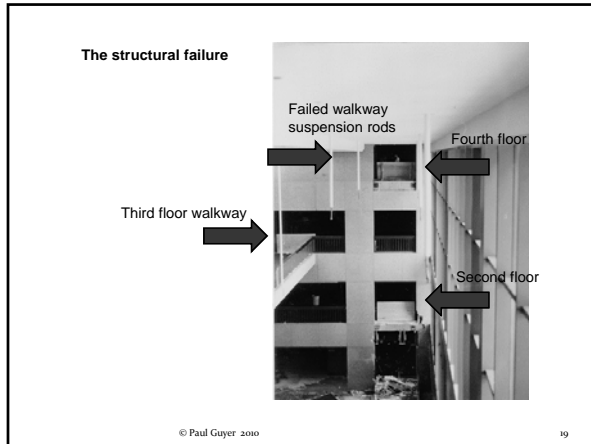

The structural failure

- ❑ What went wrong?
- ❑ One theory suggested at an early stage was that the people dancing on the fourth floor walkway induced harmonic vibrations that reached critical amplitude that resulted in failure. This theory was disregarded when evidence of a different cause became apparent.
- ❑ The cause of the failure was a change made by the steel detailer (WRW, a sub-contractor to Havens, which in turn was a sub-contractor to Eldridge) to the suspension rods design shown on the structural engineer Gillum's drawings.
- ❑ Why did WRW, at Haven's instigation, make this change? Because of two *constructability* issues....

© Paul Guyer 2010 23

The structural failure

- ❑ First, the Gillum design required continuous suspension rods approximately 40-feet long. Havens determined these would be unacceptably expensive to procure and install.
- ❑ Second, the suspension rods would have to be threaded for approximately 30-feet of their length in order to install the nut on the rod that supported the fourth floor walkway. This was determined by Havens to be unacceptably expensive to fabricate and install.
- ❑ This is the change WRW/Havens made to Gillum's design....

© Paul Guyer 2010 24

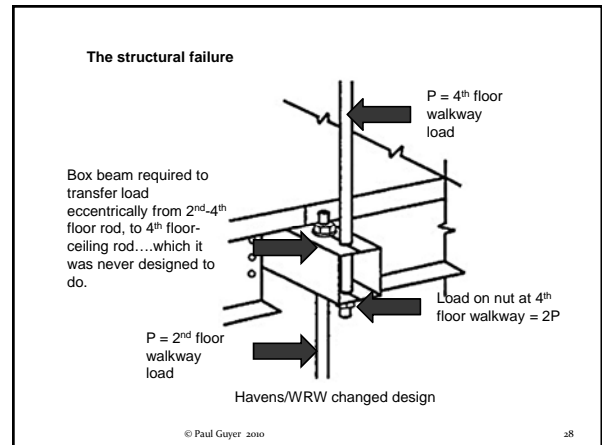
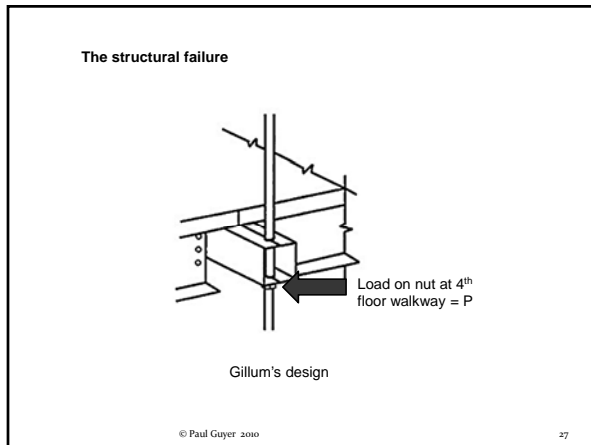
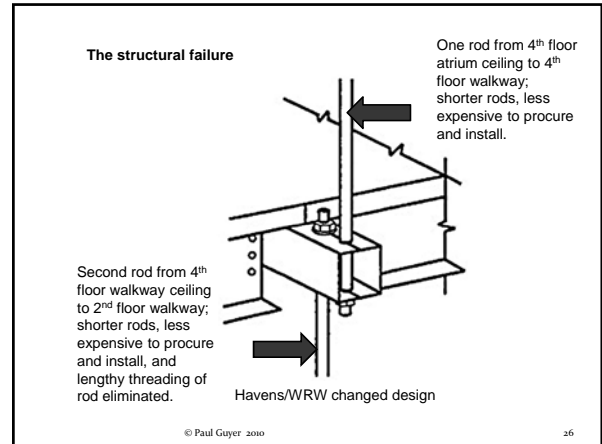
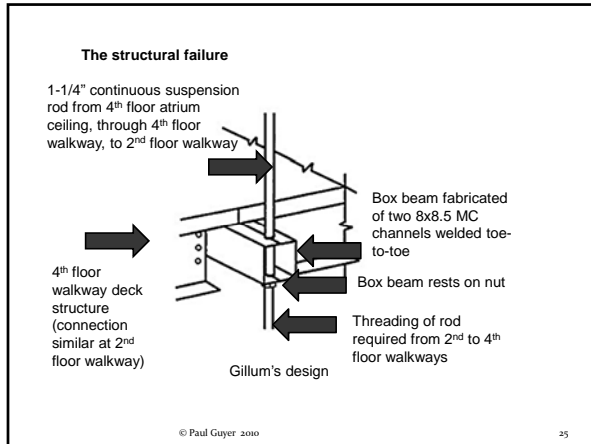

The structural failure

- And there was an additional consideration: Gillum's original design sized the suspension rods such that they were strong enough to support only 60% of the imposed load....based on code-allowable stresses.
- But given the difference between code-allowable and yield stresses of the materials....was this a fatal error?
- And here is what happened....

© Paul Guyer 2010 29

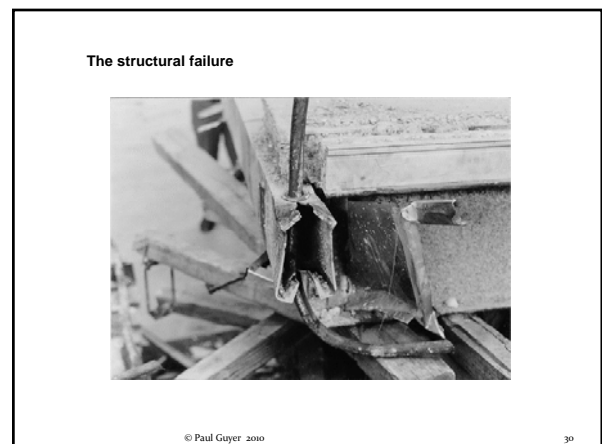

The structural failure



© Paul Guyer 2010 31

The structural failure

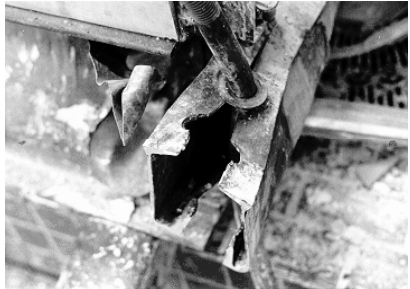

© Paul Guyer 2010 32

The structural failure



© Paul Guyer 2010 33

The post-mortem

- ❑ And now begins the finger-pointing....
- ❑ Havens said they notified Gillum of the change by telephone.
- ❑ Gillum denies having received any such telephone call.
- ❑ Havens submitted over 40 steel fabrication drawings to Gillum for review. Included on one of these drawings was the fatal change.
- ❑ Gillum reviewed and returned the drawings stamped "Reviewed only for conformance with the design concept and for compliance with the information given in the contract documents."
- ❑ Havens proceeded to fabricate and erect the structural steel for the project in accordance with the fabrication drawings.

© Paul Guyer 2010 34

The post-mortem

- ❑ Several participants in the design-construction process purported to have told Gillum of concerns that they had about the safety of the proposed change, including: the construction detailer (WRW), the steel fabricator (Havens), the architect (PBNDML), and a technician. Is there anything interesting about these allegations?

© Paul Guyer 2010 35

The post-mortem

- ❑ The National Bureau Standards (today, the National Institute of Standards and Technology) was the lead agency in the technical investigation following the collapse. NBS determined essentially that the failure was due to:
 - the design change which led to the failure at the box beam-nut-suspension rod connection
 and was contributed to by:
 - failure to design the suspension rods to code-approved stresses
 - failure to provide redundant suspension rods

THE NBS specifically concluded that "Under the original hanger rod arrangement (continuous rod) the box beam-hanger rod connections as shown on the contract drawings would have had the capacity to resist the loads estimated to have been acting at the time of collapse."

© Paul Guyer 2010 36

The post-mortem

- As part of its investigation the NBS looked at the historical development of professional and trade practices in steel structure design and construction industry. This is what it found....
 - Prior to the Second World War most steel structures were designed using rivets and the structural engineer designed and detailed all connections (sized members and rivets, detailed rivet patterns and all other aspects of the connections), and provided all of these details on the structural drawings. Construction contractors then constructed the structure in strict accordance with the working drawings.
 - After the Second World War other connection types were developed such as bolted and welded.

The post-mortem

- In response to this changed environment, steel fabricators and erectors developed their own preferences for connection details and began to make a case that they should be allowed to design connection details to suit their preferences.
- Out of this environment, the American Institute of Steel Construction (AISC) developed a handbook of steel connection details that could be used by steel fabrication and erection companies to select straight-forward connection details, based on loads specified by the structural engineer.
- Given the economic pressures under which structural engineers operated, they were largely comfortable in surrendering this connection detailing responsibility to fabricators/erectors on "standard" connections.

The post-mortem

- Thus, the contemporary practice developed whereby the steel fabricator/erector prepared connection details for standard connections utilizing the AISC manual, and the structural engineer detailed only non-standard details on his drawings.
- In this case, the suspension rod/walkway deck connection was not a standard connection, and it was detailed by the structural engineer Gillum on his working drawings.

The post-mortem

- The Missouri registration board (Missouri Board) "convicted" (a questionable term, given that this was an administrative, not criminal, sanction) Gillum and a professional engineer in his employ of:
 - Gross negligence
 - Misconduct
 - Unprofessional conduct in the practice of engineering
 and cancelled their Missouri professional engineering registrations.
 - Major civil damage claims were paid to victims and their estates through judgments and settlements, primarily by the owner, Crown and its insurers....as the clear deep-pockets in the event.

The post-mortem

- Now let's take a brief look at the 377 page report prepared by the National Bureau of Standards.

The post-mortem

- Now let's take a brief look at the 954 page transcript of the administrative hearing conducted by the Missouri engineering registration board.

The post-mortem....a recent e-mail

Paul,
I read your paper "Ethical Issues from the Kansas City Hyatt Hotel Collapse". I thought that I would offer a couple of other elements that were not contained in your paper. I was called to the Hyatt, by an acquaintance with the Kansas City Fire Department the evening of the collapse. I also worked with Dr. George Hauck to help study and test the connection that failed.

The original drawings showed welds connecting the 2 channel flanges together that were not appropriate. The call out was for a complete joint penetration (CJP) weld. But even 1981 there were limits per the American Welding Society. The weld indicated was a butt weld, but the flange material was greater than that allowed for a single sided butt weld CJP. Because of the toes of the MC shapes, it was difficult to impossible to weld a prequalified CJP. The Havens detailer should have shown an appropriate CJP, or should have developed something else such as a built up box section to achieve structural and architectural intent.

© Paul Guyer 2010 43

The post-mortem....a recent e-mail

If a built up section was used, the engineer may have noticed that the web of the built up section was grossly overstressed by simple observation. The web is less than 1/4" thick.

If the section was constructed as initially envisioned by the structural engineer with a single hanger rod, the connection would have been still grossly overstressed. It is likely that the stresses would have been to the point of failure sometime in the life of the building. In tests, we observed the web to bow when we snugged the connection and registered zero load. The connection was deforming in the plastic range at 13.5 kips. We had rupture at 20.5 kips. Dead load on a single connection was 8.8 kips. Thus failure live load on a single walk was between 4.7 kips and 11.7 kips. This would translate to a failure load range of 39 psf and 98 psf. Seiden and Page tested the stair in the lobby to an applied load of about 160 psf. Both the stair and walkway were supposed to be designed for the same live load.

© Paul Guyer 2010 44

The post-mortem....a recent e-mail

Following the Hyatt collapse, Jack Gillum's license to practice engineering was revoked in Missouri. Every other state in which he held a license also revoked his license. Jack Gillum continued to practice engineering in the only state that did not revoke his license. That state was California. The State of California brought an action against Jack Gillum about 10 years after the Hyatt collapse. They reinstated his CE license after 30 days. This can be accessed on the BORPELS web site. http://www.pels.ca.gov/consumers/disc_a_lshtml#gillum_514

After the localized roof collapse during construction, Crown Center Redevelopment Corp. solicited and funded a complete check of all of the structure. Gillum and Colaco performed this service using Dr. Greg Luth in charge of this effort. Dr. Luth is currently a professor at Stanford University.

Any time Crown Center Redevelopment Corp. learned of any doubt of the structural safety, they funded a test or an additional check. Seiden and Page supervised the load testing of the cantilevered stairway pictured in many of the photographs in your report. The test was performed by General Testing. The stair performed very well.

I thought that you might find this interesting.

© Paul Guyer 2010 45

Was the disaster preventable?

- Clearly, yes, if....
 - Havens/WRW had properly designed the changed detail
 - The improperly changed detail had been noted and corrected by Gillum
- Other actions that may have prevented the collapse were....
 - if Gillum had provided redundant suspension rods in its design
 - if Gillum had sized the suspension rods in accordance with code-approved stresses

© Paul Guyer 2010 46

Were the post-mortem conclusions appropriate?

- The post-mortem effectively placed all of the blame on the structural engineer of record, Gillum. But this raises questions....
- What is the responsibility of Havens, which held itself out to its customers as providing engineering services, in addition to fabrication and erection services, and instigated the change for economic reasons?
- What is the responsibility of WRW, which designed the change under the direction of its registered professional engineer?
- What is the responsibility of the architect PBNMML which held itself out to its customers as being the master designer responsible for all aspects of the design?

© Paul Guyer 2010 47

Were the post-mortem conclusions appropriate?

- What is the responsibility of Eldridge, which held itself out as responsible for all construction, including that of its sub-contractors Havens and WRW?
- What is the responsibility of the owner, Crown, which did not fund additional structural engineering review by Seiden Page after the earlier atrium roof collapse, and after Gillum recommended and requested funding for a full-time representative at the job site?

© Paul Guyer 2010 48

Were the actions of the profession appropriate?

- ❑ Although certainly morally defensible, is ASCE's position that "the structural engineer" is responsible for all aspects of the structural design *practicable* in light of the fact that....
 - there are other members of the design-construct team who affect the structural design and construction, and they are often outside the control of "the structural engineer."
 - there are very significant economic pressures under which "the structural engineer" and other members of the design-construct team must operate on typical projects.
- ❑ Similarly, although NSPE's Canon No. 1 expresses a laudable ideal....is it practicable, and does it provide any useful guidance in the "real world?"

© Paul Guyer 2010 49

Would conclusions be different if the failure occurred today?

- ❑ This incident occurred over 25 years ago. Have there been changes in the building design and construction industry that would lead to different conclusions if the incident occurred today? Specifically, what should be the responsibilities under a "design-build" construction delivery process where a construction contractor holds itself out to its customers as qualified to design as well as construct buildings?

© Paul Guyer 2010 50

How do we prevent similar events in the future?

- ❑ Here are some realities....
 - **The building design and construction process is highly complex.** It is not only technically complex, it is organizationally complex. It involves many people with different capabilities, motivation levels and economic objectives.
 - **People always make mistakes.** It is human nature to make mistakes. Any process where people are involved needs to recognize this.
 - **Economic pressures are very powerful forces in the building design and construction industry.** All of the members of the building design and construction team are under enormous economic pressures. Most if not all obtained their work through price competition.... competitive bidding.

© Paul Guyer 2010 51

How do we prevent similar events in the future?

- **It is axiomatic that someone cannot be held responsible for achieving an objective, without commensurate authority....** and in building design and construction an essential part of that authority is *budget authority*. It is also axiomatic, however, that owners will *never* give up budget authority to anyone.
- **Although all members of the design and construction team do not have the same level of expertise, all do have some level of expertise.** Therefore, take advantage of this. *Force as many sets of eyes as possible to look at the drawings!*

© Paul Guyer 2010 52

How do we prevent similar events in the future?

- ❑ In light of these realities, avoidance of tragic incidents such as this on future projects requires a *strategy* that forces as many knowledgeable members of the design and construction team to participate in and take some degree of responsibility for design and construction decisions as possible.

© Paul Guyer 2010 53

How do we prevent similar events in the future?

- ❑ The cause of this tragedy was an ineffective change management system. To prevent this type of tragedy in the future, three things are needed:
 - **A clearly defined organizational structure**
 - **Clearly defined and enforced process procedures**
 - **Independent constructability review**
- ❑ **Organizational Structure and Procedures:** Here is what the design and construction organizational structure and decision-making process should look like....

© Paul Guyer 2010 54

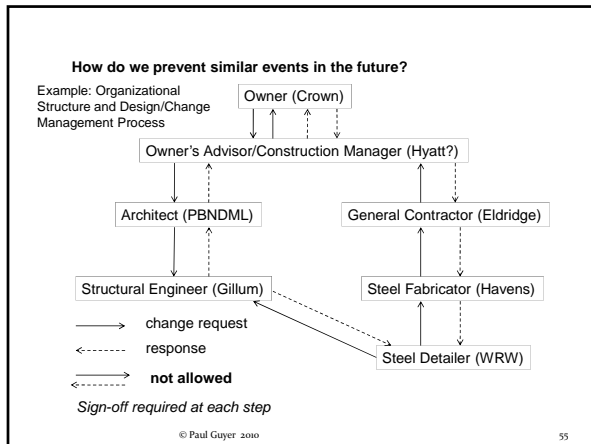

How do we prevent similar events in the future?

- Is this structure/procedure inefficient? No. Here is why...
 - It forces as many "sets of eyes" as possible to look at contract documents (drawings, specifications, changes)
 - Although team members have different levels of expertise, all have *some level* of expertise, and therefore can potentially spot errors and questionable actions
 - The requirement for "sign-off" at each level forces team members to *take things seriously* and accept some level of responsibility
 - The owner's participation in this process is essential *because only the owner has budget authority*
 - There are well accepted methodologies where time is critical to issue directives with post-facto sign offs

© Paul Guyer 2010 56

How do we prevent similar events in the future?

- **Constructability Review.** And here is a very important component of the design and construction process on any substantive project...a *constructability review*, ideally coupled with a *value engineering review*.
- A *constructability review* is an advisory review of the 100% working drawings and specifications by an independent team of experienced design and construction professionals intended to identify features indicated by the working drawings and specifications that are impractical, unsafe or that can be accomplished in a more cost effective manner. The abnormally long, threaded suspension rods indicated by the original design for this project are the type of feature a *constructability review* could be expected to identify, which would have allowed the structural engineer to develop a more practicable solution that would have prevented the design change made by the steel detailer/fabricator WRW/Havens.

© Paul Guyer 2010 57

How do we prevent similar events in the future?

- A *value engineering review* is an advisory review of the 100% working drawings and specifications by an independent team of experienced design and construction professionals intended to develop cost savings by proposing more cost effective design features and details.
- A *constructability review* and a *value engineering review* both add moderate cost to a design budget, but if they are proposed as a teamed undertaking, an owner can often be convinced to provide the additional funding required because of the real probability that more than enough construction savings can be realized that will offset the additional cost of the reviews.

© Paul Guyer 2010 58

How do we prevent similar events in the future?

- To repeat...to prevent this type of tragedy on future projects:
 - **Force as many sets of eyes as possible to look at the drawings and specifications**
 - **Force team members to take things seriously by requiring sign-off on every substantive decision and action.**
 - **Convince the owner to fund an independent *Constructability Review*.**

© Paul Guyer 2010 59

How do we prevent similar events in the future?

- An issue was raised to the effect that the Kansas City building department was said to be overworked and did not adequately check the structural drawings and calculations, and might thereby have discovered the fatal defect.
- The one positive outcome of this event was a heightened awareness nationwide of the importance of the building department plan checking activity. This generally resulted in better funding and more rigorous plan checking in building departments throughout the country.

© Paul Guyer 2010 60

And now....

THE QUIZ

© Paul Guyer 2010

61

1. This structural collapse resulted in _____ deaths.
 - a. 99
 - b. 104
 - c. 109
 - d. 114
2. There were _____ suspended walkways that crossed the atrium lobby of the hotel.
 - a. 5
 - b. 4
 - c. 3
 - d. 2
3. The owner of the hotel was the _____.
 - a. Crown Center Corporation
 - b. Hyatt Hotel Corporation
 - c. City of Kansas City, Missouri
 - d. The City of Kansas City, Kansas

© Paul Guyer 2010

62

4. While under construction in 1979, _____ collapsed.
 - a. a portion of the seventh (tower) floor deck structure
 - b. a portion of the tower scaffolding
 - c. a construction crane
 - d. a portion of the atrium roof
5. The construction contract for the project was awarded based on _____.
 - a. time-and-materials
 - b. negotiations
 - c. competitive bidding
 - d. design-build
6. The steel fabrication and erection sub-contractor (Havens) held itself out to its customers as being capable of providing _____.
 - a. architectural services
 - b. demolition services
 - c. engineering services
 - d. recycling services

© Paul Guyer 2010

63

7. The structural detail that caused the collapse was designed by _____.
 - a. PBNMML
 - b. Gillum
 - c. Havens (WRW)
 - d. Seiden Page
8. On _____ occasions Gillum requested funding to have a full-time project quality control representative on the job-site, but these funding requests were not approved by Crown.
 - a. 2
 - b. 3
 - c. 4
 - d. 5
9. The structural specifications for the project were prepared by _____.
 - a. PBNMML
 - b. Gillum
 - c. Havens (WRW)
 - d. Seiden Page

© Paul Guyer 2010

64

10. One of Haven's concerns about the walkway suspension rods in Gillum's original design is that they were _____.
 - a. the wrong grade of steel
 - b. exceptionally long
 - c. fabricated from ten short segments
 - d. subject to corrosion
11. Another of Haven's concerns about the walkway suspension rods in Gillum's original design was that they required extensive _____.
 - a. post-tensioning
 - b. pre-treatment
 - c. threading
 - d. galvanizing
12. One procedural approach suggested to avoid tragedies such as this in the future is a/an _____.
 - a. transcript file
 - b. value engineering review
 - c. pre-construction conference
 - d. constructability review

© Paul Guyer 2010

65

13. The change Havens/WRW made to the connection detail at the fourth floor walkway deck and the suspension rods increased the load on the suspension rod nut that the box beam rested on by a factor of about _____, from that in the original Gillum design.
 - a. 3.0
 - b. 2.5
 - c. 2.0
 - d. 1.5
14. The collapse might not have occurred if _____ suspension rods had been installed.
 - a. transverse
 - b. redundant
 - c. fewer
 - d. lateral
15. Gillum prepared about 60 drawings for the structural steel work for the project and Havens/WRW prepared about _____.
 - a. 40
 - b. 30
 - c. 20
 - d. 10

© Paul Guyer 2010

66

